

**Input Parameters**

NOMINAL INPUT VOLTAGE RANGE	100 - 240VAC
MAX. INPUT VOLTAGE RANGE	90-264VAC
INPUT FREQUENCY	47-63Hz
MAXIMUM INPUT CURRENT	11 A AC
INRUSH CURRENT	<40 AMPS

**Output Parameters**

**Adjustment and Derating.**

The Vega 450 series is designed to provide a max output power of 450W at nominal output voltages. The following rules must be obeyed in loading the unit:

- Calculate user power for each module (volts x amps).
- Add all the individual module powers together. The total power must not exceed the value given.
- Calculate secondary transformer turns x amps for each module. See the outputs table for transformer secondary turns.
- Add all the module turns x amps together and this must not exceed the ampere turns.
- If necessary reduce the loading until the conditions are met, ie. power and ampere-turns maxima.

Note: Adjusting output voltage beyond the stated range may cause overvoltage protection (OVP) to operate, whereby all outputs will turn off. To reset OVP, turn back output voltage adjustment and remove the mains supply for 30 seconds and then switch back on.

Cooling Option	Max Ambient	Dual Width Modules Fitted	Max Total Power	Max Total Ampere Turns (AT)	Special AT Limit **	Module Current Rating
F Standard Fan - Forward Airflow	50	No	450	180	-	100%
		Yes	450	180	180	100%
R (Standard Fan - Reverse Airflow)	45	No	450	180	-	100%
		Yes	450	180	158	90%
	50	No	440	176	-	100%
		Yes	420	180	158	90%
Q (Quiet Fan - Forward Airflow)	50	No	450	180	-	100%
		Yes	450	180	140	100%
P (Quiet Fan - Reverse Airflow)	40	No	440	176	-	100%
		Yes	450	180	152	85%
	45	No	400	160	-	100%
		Yes	420	180	152	85%
	50	No	350	140	-	100%
		Yes	370	180	143	85%
C (Customer Air Option)	50	see following detail				

\*\* For products with dual width modules the following rules apply:

One Dual Width module:

Total Ampere turns for modules in slots 1 to 4 must be < the value shown in Special AT Limit column.

Total Ampere turns for modules in slots 2 to 5 must be < the value shown in Special AT Limit column.

Two Dual Width modules:

Total Ampere turns for modules in slots 1 to 3 must be < the value shown in Special AT Limit column.

Total Ampere turns for modules in slots 2 to 5 must be < the value shown in Special AT Limit column.

**Customer Air Cooling (option C):**

The following method must be used for determining the safe operation of PSUs when C option (Customer Air) is fitted, ie fan not fitted to PSU.

For PSUs cooled by customer supplied airflow the components listed in 6 must not exceed the temperatures given. Additionally ratings specified for units with an internal fan must still be complied with, eg mains input voltage range, maximum output power, ampere turns, module voltage / current ratings and maximum ambient temperature. To determine the component temperatures the heating tests must be conducted in accordance with the requirements of EN60950:1992/A11:1997 Clause 5.1. Consideration should also be given to the requirements of other safety standards.

Test requirements include: PSU to be fitted in its end-use equipment and operated under the most adverse conditions permitted in the end-use equipment handbook/specification and which will result in the highest temperatures in the PSU. To determine the most adverse conditions consideration should be given to the end use equipment maximum operating ambient, the PSU loading and input voltage, ventilation, end use equipment orientation, the position of doors & covers, etc. Temperatures should be monitored using type K fine wire thermocouples (secured with cyanoacrylate adhesive, or similar) placed on the hottest part of the component (out of any direct airflow) and the equipment should be run until all temperatures have stabilised.

CIRCUIT REF.	DESCRIPTION	MAX. TEMP (°C)
-	Power transformer primary, secondary and core	130
T1, TX101, TX201	Module current transformer windings	127
XQ1	E & F Primary option transformers	90
XTR1	EV & FV Primary option transformers	90
TX1	xEW & xFW Primary option transformers	130
L1, L2, XT601	Choke winding	110
T2	Choke winding	117
Various	All other choke & transformer windings	110
RLY1	Relay	100
C15	X capacitor	100
Various	All other X and electrolytic capacitors	105
L4	Choke winding	120
C2, C3, C4	Electrolytic Capacitor	67
Various	All other 10mm dia Electrolytic Capacitor	80
Various	All other 12.5mm dia Electrolytic Capacitor	85

**Modules**

Modules	Note	Output Range	Current	Slots	Turns	Max. Current Limit	Settings for hazardous energy
<b>Standard Modules</b>							
B1L		1.8-3.8V	20A	1	1	25A	-
B1H		3.9-5.5V	20A	1	1	25A	-
B2		5.0-9V	25A	1	2	31.3A	>7.6V
B3		9.1-16.2V	12A	1	3	15A	>16V
B5		21.6-31V	6A	1	5	7.5A	>32V
C1		1.8-4.1V	35A	1	1	43.8A	>5.4V
CIY	1	1.8-4.1V	40A	1	1	50A	-
C3		9.1-16.2V	18A	1	3	22.5A	>10.6V
C4		16.3-21.5V	14A	1	4	17.5A	>13.7V
C5		21.6-31V	10A	1	5	12.5A	>19.2V
D1L	2	1.8-3.8V	50A	1.5	1	62.5A	>3.8V
D1H	2	3.9-5.5V	50A	1.5	1	62.5A	>3.8V
D2	2	3.8-9V	45A	1.5	2	56.25A	>4.2V
D3	2	8-16.5V	24A	1.5	3	30A	>8V
D4	2	14-21.5V	18A	1.5	4	22.5A	>10.6V
D5	2	21-28V	15A	1.5	5	18.75A	>12.8V
E1		1.8-3.8V	60A	2	1	75A	>3.2V
E2	3	3.8-8V	60A	2	2	75A	>3.2V
E3L		8-13.9V	40A	2	3	50A	>4.8V
E3H		14-15V	36A	2	3	45A	>5.3V
E4		14-19.9V	30A	2	4	37.5A	>6.4V
E5L		20-24V	27A	2	5	33.8A	>7.1V
E5H		24-28V	25A	2	5	31.3A	>7.6V

Modules	Note	Output Range	Current	Slots	Turns	Max. Current Limit	Settings for hazardous energy
<b>Standard Modules</b>							
F1	4	1.8-3.8V	80A	2	1	100A	>2.4V
F2	5	3.8-8V	75A	2	2	100A	>2.4V
L1		4.2-5.5V	35A	1	1	43.8A	>5.4V
H1L/1L		1.8-3.8V	12A	1	1	15A	-
		1.8-3.8V	8A		1	12A	-
H1L/1H		1.8V-3.8V	12A	1	1	15A	-
		3.9-5.5V	8A		1	12A	-
H1H/1L		3.9-5.5V	12A	1	1	15A	-
		1.8-3.8V	8A		1	12A	-
H1H/1H		3.9-5.5V	12A	1	1	15A	-
		3.9-5.5V	8A		1	12A	-
H1L/2		1.8-3.8V	12A	1	1	15A	-
		5.6-9V	6A		2	9A	-
H1H/2		3.9-5.5V	12A	1	1	15A	-
		5.6-9V	6A		2	9A	-
H1L/3		1.8-3.8V	12A	1	1	15A	-
		9.1-16.2V	6A		3	9A	-
H1H/3		3.9-5.5V	12A	1	1	15A	-
		9.1-16.2V	6A		3	7.5A	-
H1L/4		1.8-3.8V	12A	1	1	15A	-
		16.3-25V	4.5A		4	6A	-
H1H/4		3.9-5.5V	12A	1	1	15A	-
		16.3-25V	4.5A		4	6A	-
H2/1L		5.6-9V	10A	1	2	15A	-
		1.8-3.8V	8A		1	12A	-
H2/1H		5.6-9V	10A	1	2	15A	-
		3.9-5.5V	8A		1	12A	-
H2/2		5.6-9V	10A	1	2	15A	-
		5.6-9V	6A		2	9A	-
H2/3		5.6-9V	10A	1	2	15A	-
		9.1-16.2	6A		3	7.5A	-
H2/4		5.6-9V	10A	1	2	15A	-
		16.3-25V	4.5A		4	6A	-
H3/1L		9.1-16.2V	10A	1	3	15A	>16V
		1.8-3.8V	8A		1	12A	-
H3/1H		9.1-16.2V	10A	1	3	15A	>16V
		3.9-5.5V	8A		1	12A	-
H3/2		9.1-16.2V	10A	1	3	15A	>16V
		5.6-9V	6A		2	9A	-
H3-3		9.1-16.2V	10A	1	3	15A	>16V
		9.1-16.2V	6A		3	7.5A	-
H3/4		9.1-16.2V	10A	1	3	15A	>16V
		16.3-25V	4.5A		4	6A	-
H5/1L		16.2-31V	5A	1	5	7.5A	>32V
		1.8-3.8V	8A		1	12A	-
H5/1H		16.2-31V	5A	1	5	7.5A	>32V
		3.9-5.5V	8A		1	12A	-
H5/2		16.2-31V	5A	1	5	7.5A	>32V
		5.6-9V	6A		2	9A	-

Modules	Note	Output Range	Current	Slots	Turns	Max. Current Limit	Settings for hazardous energy
<b>Standard Modules</b>							
H5/3		16.2-31V	5A	1	5	7.5A	>32V
		9.1-16.2	6A		3	7.5A	-
H5/4		16.2-31V	5A	1	5	7.5A	>32V
		16.3-25V	4.5A		4	6A	-
<b>Serialized Modules</b>							
BB4		32.6-43V	10A	2	8	12.5A	>19.2V
CC3		18.2-32.4V	18A	2	6	22.5A	>10.6V
CC5	6	48.1-62V	10A	2	10	12.5A	>19.2V
DD4		28-43V	18A	3	8	22.5A	>10.6V
DD5	6	42-56V	15A	3	10	18.75A	>12.8V
EE2		7.6-16V	55A	4	4	75A	>3.2V
HH5/3	6	25.3-47.2V	5A	1	8	7.5A	>32V
HH5/4	6	32.5-56V	4.5A	1	9	6A	>40V
C5B4	6	43-48V	10A	2	9	12.5A	>19.2V
<b>Paralleled Modules</b>							
Z2(D1L+D1L)		1.8-3.8V	95A	3	1+1	125A	>1.9V
Z3(E1+E1)		1.8-3.8V	114A	4	1+1	150A	>1.6V
Z4(D1H+D1H)		3.9-5.5V	95A	3	1+1	125A	>1.9V
Z6(E2+D1H)		3.9-5.5V	104.5A	3.5	2+1	137.5A	>1.7V
Z7(D3+D3)		8-16.5V	45.6A	3	3+3	60A	>4V
Z18(L1+L1)		4.2-5.5V	66.5A	2	1+1	87.5A	>2.7V
<b>Wide Range Modules</b>							
W2	7	0.25-7.5V	30A	1	2	37.5A	>6.4V
W5	7	0.25-32V	8.5A	1	5	9.5A	>25.2V

**Module Limitations - Notes:**

- C1Y module is only permitted in slot 1.
- For PSUs with three D modules fitted or two D modules and an E module in slots 4/5 then D1L & D1H in slots 2/3 is limited to 42A and in slots 4/5 is limited to 47A. D2 in slots 2/3 is limited to 40A.
- E2 and F2 module fitted in slots 4/5 is limited to 55A.
- F1 module is only permitted in slots 1 and 2.
- F2 module is limited to 40°C ambient for 80A load, and at 50°C must not exceed 75A load.  
Important Note: The above module limitations apply to individual modules whether these are stand alone modules, or part of a series or parallel pair.
- Modules CC5, DD5, C5B4, HH5/3 and HH5/4 must be considered non-SELV for IEC/EN60950, UL 1950, CSA22.2 No. 950, IEC/EN60601-1 and UL2601-1, since under a fault condition they may reach voltages in excess of SELV levels. As a result, all outputs on products containing any of these modules must be considered non-SELV.
- W2 & W5 is followed by V or R indicating Voltage or Resistance programming, followed by 1, 2, 3 or 4, where:
  - 1 = Inhibit + Fixed or prog current limit + Fixed 0/V.
  - 2 = Inhibit + Fixed or prog current limit + Track 0/V.
  - 3 = Enable + Fixed or prog current limit + Fixed 0/V.
  - 4 = Enable + Fixed or prog current limit + Track 0/V.

**Energy Hazards.**

Certain modules are capable of providing hazardous energy (240VA) according to output voltage setting. Final equipment manufacturers must provide protection to service personnel against inadvertent contact with these module output terminals. If set such that hazardous energy can occur then the module terminals or connections must not be user accessible.

**Approval Limitations:**

**Use in North America (AC units only)**

When this product is used on 180VAC-250VAC mains with no neutral, connect the two live wires to L (live) and N (neutral) terminals on the input connector. In this instance double pole fusing is required.

**Important safety instructions**

These products are not customer serviceable. Repairs may only be carried out by Lambda UK or their authorised agents. These products are not authorised for use as critical components in nuclear control systems, life support systems or equipment for use in hazardous environments without the express written approval of the Managing Director of Coutant Lambda Ltd.

**High voltage warning**

Dangerous voltages present within the power supply. Do not remove covers.

**Hot external surfaces**

Section 6 of the Health and Safety at Work Act requires that manufacturers have an obligation to protect service engineers as well as users. In order to comply with this, a label must be fitted to these products which is clearly visible to service personnel accessing the overall equipment, and which legibly warns that surfaces of these products may be hot and must not be touched when the products are in operation.

**Safety earthing screw.**

These products employ special safety earthing screws which connect the cover to the base. They must not be removed.

**Safety - class of protection**

These products are designed for the following parameters: Material Group IIIa, Pollution Degree 2, Overvoltage Category II, Class 1 (earthed), Indoor use as part of an overall equipment such that the Vega product is accessible to service engineers only.

**Safety approvals**

UL1950 and CSA22.2 No.950 - UL Recognised. C-UL for Canada.  
IEC/EN60950 - BSI Kitemark and CE mark.  
CE marking when applied to any Vega product, indicates compliance with the Low Voltage Directive (73/23EEC) as modified by the CE Marking Directive (93/68/EEC) in that it complies with EN60950.  
IEC/EN61010-1 and IEC/EN60601-1. CB Report.  
UL2601-1 and UL3101-1-UL Recognised, C-UL for Canada.

**Input markings and symbols**

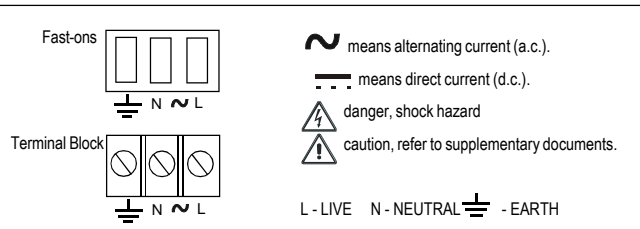

**Environmental parameters**

**Operation**  
Temperature 0 to 50°C (derating 2.5%°C above 50°C to 65°C - Not covered by approvals).  
Humidity 5 to 95% RH non-condensing. Air Pressure 78kPa to 106kPa.  
Altitude -200m to 3000m. (-200m -2000m for UL2601-1 and IEC/EN60601-1)

**Storage and Transportation**  
Temperature -40°C to +85°C. Humidity 5% to 95% RH non-condensing.  
Air Pressure 54kpa to 106kpa. Altitude -200m to 5000m.

**Vibration and shock**  
10-200Hz @ 1.5G sinewave, 20G for 15 minutes in 3 axes random vibration / 3000 bumps, 10G (16mS) half sinewave.

**Cooling**  
Provided that the fan air intake and air outlet slots are not impeded, these units may be mounted in any of 4 orientations: Horizontal, on either side, or vertical with airflow upwards. For correct airflow, allow 50mm clearance around the side and ends of the product. Exceptions to orientation are covered in the product specific handbooks.

**Level of insulation**

Dielectric Strength testing is carried out as follows: Primary mains circuit to earth - 2.25 - 2.35kVDC; \*\*Primary mains circuits to transformer core - 4.25 - 4.35kVDC; \*\*Primary mains circuits to secondary -4.25 - 4.35kVDC. Outputs to each other and to earth are isolated to 200VDC. (\*\*This test is not possible with modules fitted to the unit as damage to RFI capacitors will occur).

**EMC performance**

**Emissions:** EN55022 Conducted RFI-Class A or B (dependent on product - Consult Technical Sales). Radiated RFI - Class A,  
EN61000-3-2 / A14 - Pass - Class A and D. EN61000-3-3 / A1 - Pass  
EN61000-4-2 - Level 4 Criteria B EN61000-4-3 - Level 3 Criteria B  
EN61000-4-4 - Level 4 Criteria B EN61000-4-5 - Level 4 Criteria B, (Installation Class 4, Criteria B)  
EN61000-4-6 - Level 3 Criteria B EN61000-4-11 - Pass

**General installation instructions**

The Vega family of component power supplies is designed for use within other equipment or enclosures which restrict access to authorised competent personnel only. For safe installation and operation of this product, carefully follow the instructions listed below.

- The unit covers/chassis are designed to protect only skilled personnel from hazards and must not be made user accessible.
- These products are Class 1 and must therefore be reliably earthed and professionally installed in accordance with the prevailing electrical wiring regulations and the safety standards covered herein.
- These products are IPX0, and therefore chemicals/solvents, cleaning agents and other liquids must not be used.

**Special instructions for medical applications (IEC/EN60601-1/UL2601-1)**

**Applicable to products with L, R and T filter options only.**

- These products are designed for continuous operation within an overall enclosure, and must be mounted such that access to the mains terminals is restricted. See Clause 16, IEC60601-1, EN60601-1 and UL2601-1.
- These products are NOT suitable for use in the presence of flammable anaesthetic mixtures with air or with oxygen or with nitrous oxide.
- These products are classed as ordinary equipment according to IEC60601-1 EN60601-1, UL2601-1 and are NOT protected against the ingress of water.
- Connect only apparatus complying with IEC60601-1, EN60601-1 and UL2601-1 to the signal ports.
- Except for permanently installed equipment as defined in Clause 57.6 of IEC60601-1, EN60601-1 and UL2601-1, the overall equipment in which these products are installed must have double pole fusing on the input mains supply or DC supply as appropriate. The products themselves have single pole fusing in the live line or positive DC line as appropriate.
- Reference should be made to local regulations concerning the disposal of these products at the end of their useful life.

**Special instructions for applications covered by IEC/EN61010-1 and UL3101-1.**

Whilst all individual module single outputs are classed as SELV outputs in accordance with IEC/EN60950 (<60Vdc or 42.4V peak) serried combinations of these modules may exceed these values and become hazardous output voltages. For IEC/EN61010-1 and UL3101-1 the equivalent limits are 70Vdc, 33Vrms or 46.7V peak.  
Under single fault conditions these limits are increased for IEC/EN61010-1 and UL3101-1 to 140Vdc, 55Vrms or 78V peak. Provided these levels are not exceeded, the outputs are not considered hazardous for IEC/EN61010-1 and UL3101-1.

**Mechanical parameters**

**DO NOT USE MOUNTING SCREWS WHICH PENETRATE THE UNIT BY MORE THAN 4.5 MM.**  
Vega 450 & 650 Weight 2 Kg dependent upon configuration.

**Connection details**

**Input Connections Vega 450 & 650 (see Table 1)**

Input tabs - 6.3mm x 0.8mm, tin plated brass, rated 15A. Internal fuse (F1) 16A/250 fast acting HBC fuse 6.3x32mm for Vega 650. 10A/250W (or 16A/250V) fast acting HBC fuse 6.3x32mm for Vega 450.  
Input Screw Terminals: 6-32 screws with 8.25mm spacing between screw head centres. Screw head diameter is 6.6mm.  
Input IEC 320: Rated 10A/250Vac (15A/132Vac)

Mating input faston connectors				
Brand	Colour	Wire size (awg)	Part number	Current rating
Amp	Red	22 - 18	2-520407-2	15A
Amp	Blue	16 - 14	3-520408-2	15A

**Output Connections**

Output Connector Ratings: Single slot, single output modules (B, C, L modules): Two 6.35mm fast-ons per output each rated at 18A or M4 screw terminals rated at 35A. Single slot, twin output modules (H modules): One 6.35mm fast-on per output rated at 18A or M3 screw terminals rated at 15A. Dual slot, single output modules (D, E modules): Two 9.5mm fast-ons per output each rated at 32A, or M5 screw terminals rated at 90A

**Maximum Torque Settings for Output Screw Terminals**

M3 - 0.9Nm M4 - 1.5Nm M5 - 2.0Nm

**Primary Options**

Specified Option	Pin 5 Logic 0	Pin 6 Logic 1
Inhibit	Outputs OFF	Outputs OFF
Enable	Outputs ON	Outputs ON

Logic 0 = 0-0.8V. Logic 1 = 2.0 - 5.0V with respect to 0V (Pin 3)

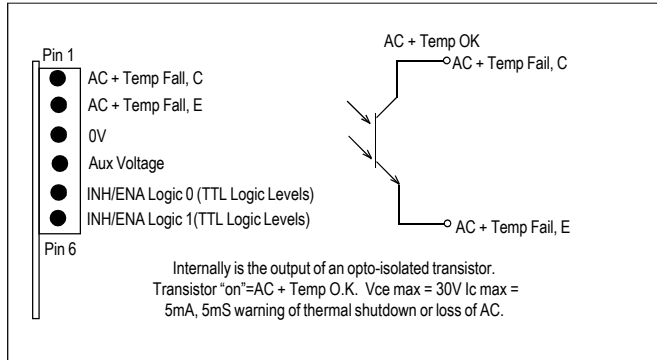

Input Filter Options		
Option	Max. Leakage at 264VAC, 63Hz	RFI EN55022 Class:
Standard	1.5mA max	B/A
M	500uA max	A
L	300uA max	A
R	100uA max	Above A
T	50uA max	Above A

**Secondary Options**

**Remote Sense Option**

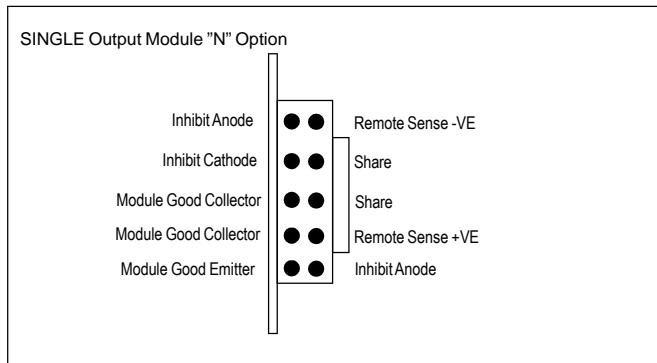

**Inhibit**

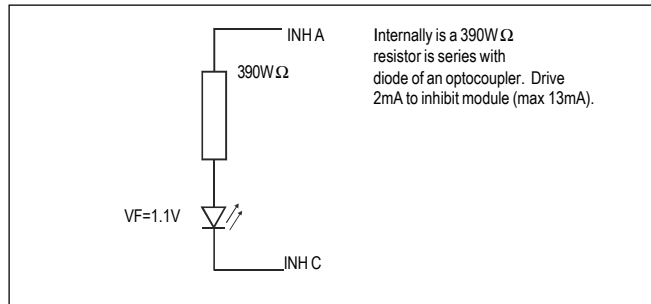

**Module Good**

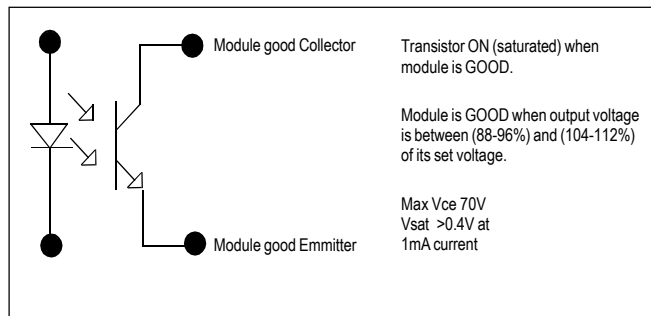

**TWIN Output Module "N" Option**

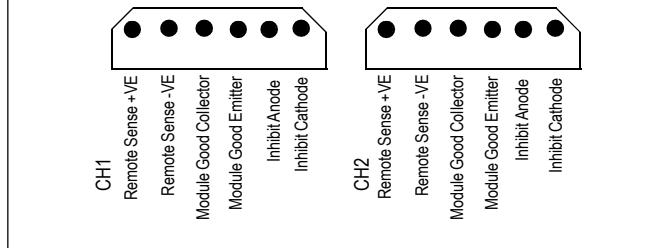

**TWIN Output Module "R" Option**

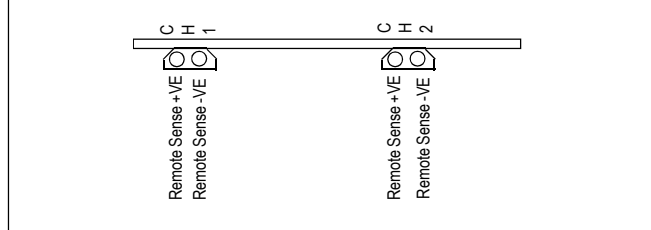

**Customer fixings**

**Customer Air and Fixing detail**

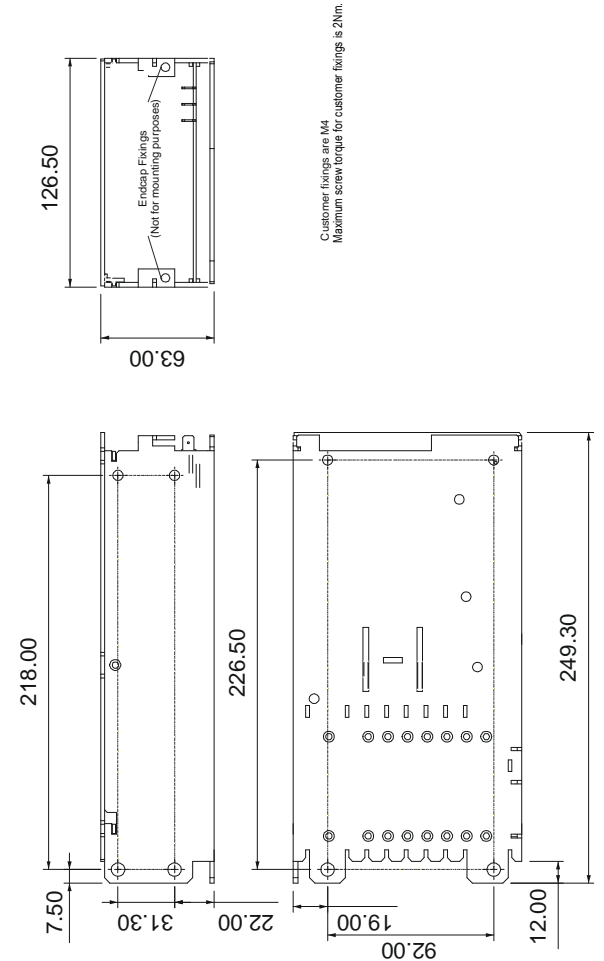

**Screw Terminal Input**

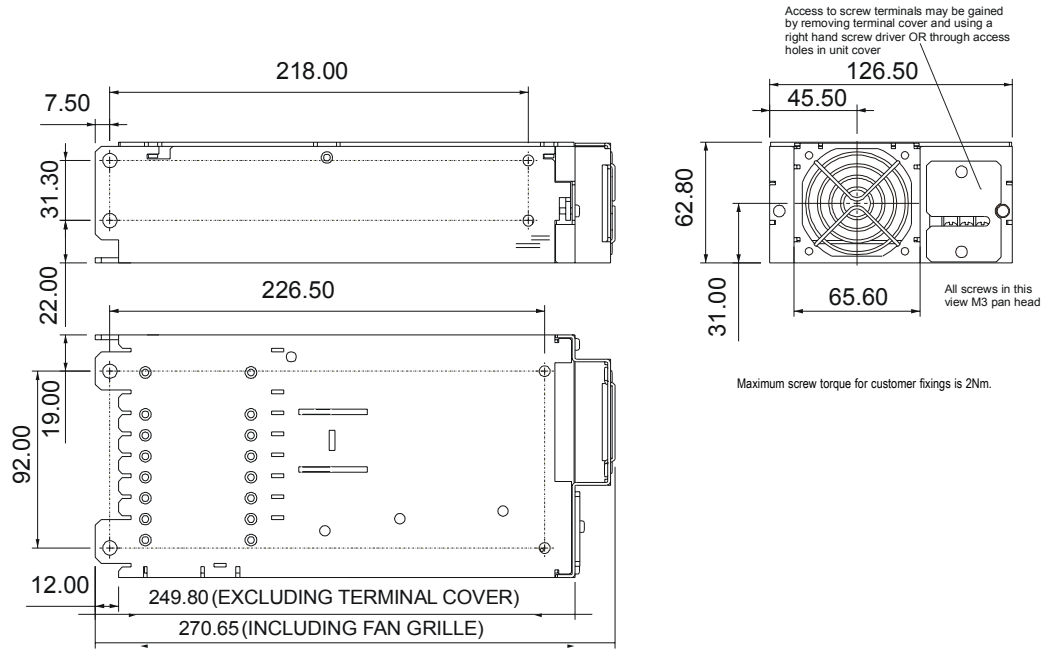

**IEC 320 (Switched) Input**

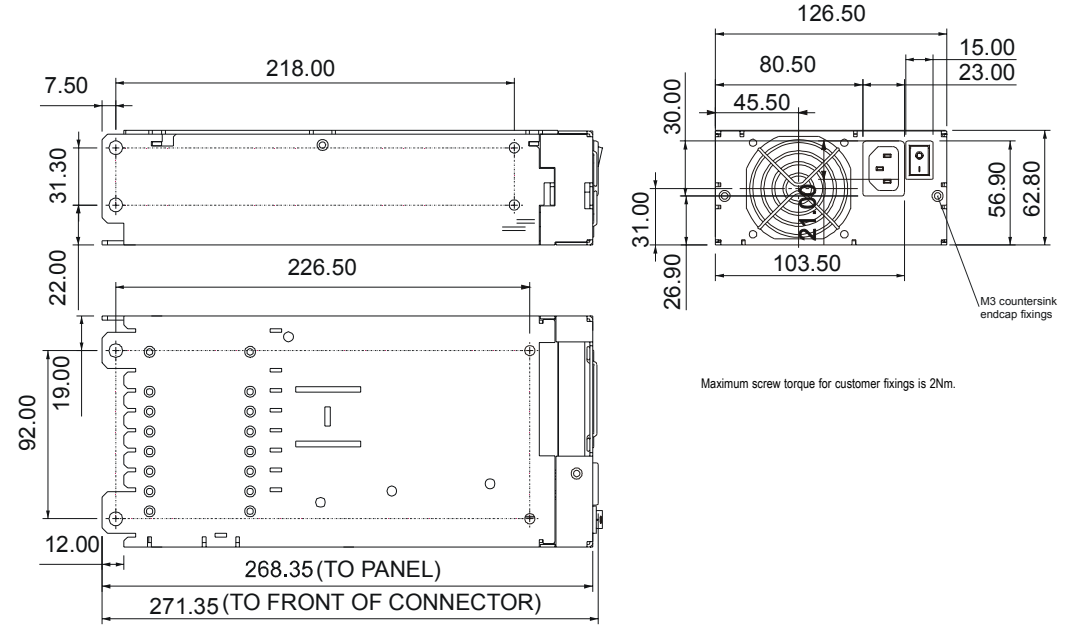

**Quick Connect (Faston) Input**

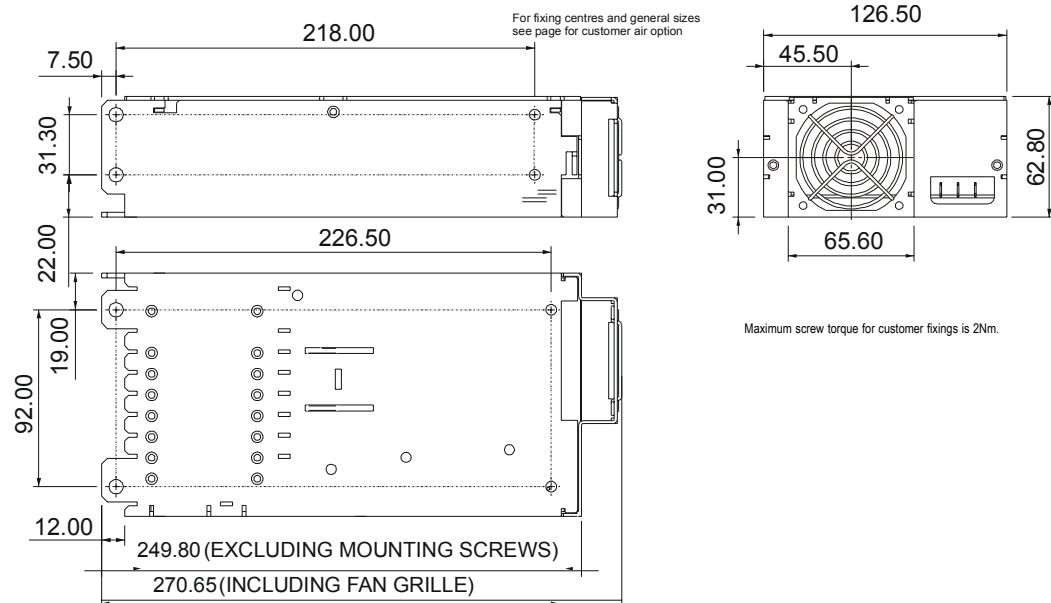

**Right Angle Screw Terminal Input**

