

## DIN Rail Mount 17.5 mm MUS 12 DC Part number 84872140



- Control relays monitoring their own power supply
- **MUS** : Over/undervoltage control
- Selectable latching (memory) function
- **MUSF** : Over/undervoltage control
- Adjustable time delays
- Control in 50 Hz, 60 Hz or DC
- True RMS measurement
- LED status indication

### Part numbers

Type	Functions	Controlled ranges
84872140 MUS 12 DC	Under/Overvoltage control	9 → 15 V DC

### Specifications

#### Supply

Polarity with DC voltage	■
AC supply voltage frequency	50 / 60 Hz ± 10 %
Galvanic isolation of power supply/measurement	No
Immunity from micro power cuts	10 ms

#### Inputs and measuring circuit

Max. measuring cycle time	250 ms/True RMS measurement
Display precision	±10 % of full scale
Repetition accuracy with constant parameters	± 0,5 %
Measuring error with voltage drift	< 1 % across the whole range
Measuring error with temperature drift	± 0,05 % / °C

#### Timing

Delay on threshold crossing	0,1 → 10 sec (0, +10 %)
Repetition accuracy with constant parameters	± 0,5 %
Reset time	1,5 s
Delay on pick-up	500 ms in AC / 1 s in DC

#### Output

Type of output	1 single pole changeover relay
Type of contacts	No cadmium
Maximum breaking voltage	250 V AC/DC
Max. breaking current	5 A AC/DC
Min. breaking current	10 mA / 5 V DC
Electrical life (number of operations)	1 x 10 <sup>5</sup>
Breaking capacity (resistive)	1250 VA AC
Maximum rate	360 operations/hour at full load
Operating categories acc. to IEC/EN 60947-5-1	AC 12, AC 13, AC 14, AC 15, DC 12, DC 13, DC 14
Mechanical life (operations)	30 x 10 <sup>6</sup>

#### Insulation

Nominal insulation voltage IEC/EN 60664-1	250 V
Insulation coordination (IEC/EN 60664-1)	Overvoltage category III : degree of pollution 3
Rated impulse withstand voltage (IEC/EN 60664-1)	4 kV (1,2 / 50 µs)
Dielectric strength (IEC/EN 60664-1)	2 kV AC 50 Hz 1 min
Insulation resistance (IEC/EN 60664-1)	> 500 MΩ / 500 V DC

#### General characteristics

Display power supply	Green LED
Display relay	Yellow LED
Casing	17,5 mm
Mounting	On 35 mm symmetrical DIN rail, IEC/EN 60715
Mounting position	All positions
Material : enclosure plastic type VO to UL94 standard	Incandescent wire test according to IEC 60695-2-11 & NF EN 60695-2-11
Protection (IEC/EN 60529)	Terminal block : IP 20 Casing : IP 30
Connecting capacity IEC/EN 60947-1	Rigid : 1 x 4 <sup>2</sup> - 2 x 2,5 <sup>2</sup> mm <sup>2</sup> 1 x 11 AWG - 2 x 14 AWG

	Flexible with ferrules : 1 x 2.5 <sup>2</sup> - 2 x 1.5 <sup>2</sup> mm <sup>2</sup> 1 x 14 AWG - 2 x 16 AWG
Max. tightening torques IEC/EN 60947-1	0,6 →1 Nm / 5,3 →8,8 Lbf.In
Operating temperature IEC/EN 60068-2	-20 →+50 °C
Storage temperature IEC/EN 60068-2	-40 →70 °C
Humidity IEC/EN 60068-2-30	2 x 24 hr cycle 95 % RH max. without condensation 55 °C
Vibrations according to IEC/EN60068-2-6	10 →150 Hz, A = 0.035 mm
Shocks IEC/EN 60068-2-6	5 g

### Standards

Marking	CE (LVD) 73/23/EEC - EMC 89/336/EEC
Product standard	NF EN 60255-6 / IEC 60255-6 / UL 508 / CSA C22.2 N°14
Electromagnetic compatibility	Immunity EN 61000-6-2/IEC 61000-6-2 Emission EN 61000-6-4/EN 61000-6-3 IEC 61000-6-4/IEC 61000-6-3 Emission EN 55022 class B
Certifications	UL, CSA, GL
Conformity with environmental directives	RoHS, WEEE

### Supply

Nominal voltage (V)	12 V DC
Power consumption at Un	1 W in DC
Operating range	7 →20 V DC
Range of adjustment	9 →15 V DC

### Inputs and measuring circuit

Hysteresis	5 →20 % of threshold
------------	----------------------

### General characteristics

Weight	75 g
--------	------

### Accessories

Description	Code
Removable sealable cover for 17.5 mm casing	84800000

### Principles



#### Overview

MUS and MUSF voltage control relays monitor single-phase DC network voltages.

These products monitor their own supply voltage.

MUS relays allow the user to choose between two operating modes :

- Under/overvoltage
- With or without fault latching

An adjustable time delay, on threshold crossing, provides immunity from transient phenomena, thus preventing spurious triggering of the output relay.

#### Operating principle

##### MUS - Under/Overvoltage controller

The operating mode is set by the user.

A switch is used to select under or overvoltage modes, with or without latching.

The switch position, and hence the operating mode, is read by the product on energisation.

If the switch is set to a non-conforming position, the product goes into fault mode, the output relay stays open, and the LEDs flash to signal the position error.

If the switch position changes while the unit is operating, all the LEDs flash but the product continues to work normally with the voltage selected on energisation prior to the change of position.

The LEDs return to their normal state if the switch is reset to its initial position defined before the last energisation.

### Principles

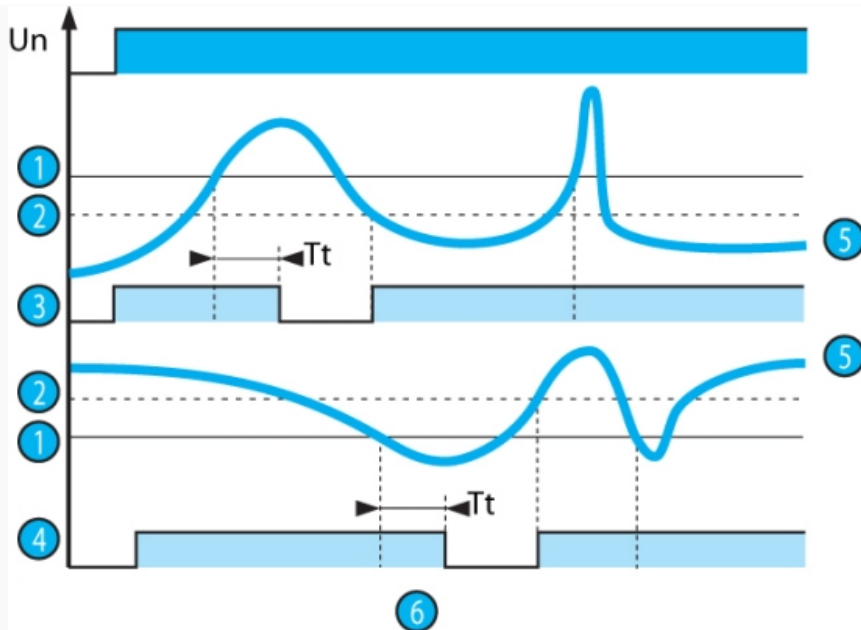

The under or overvoltage threshold value is set by a graduated potentiometer by reading the Un scale to be monitored directly.

The hysteresis is set by a graduated potentiometer from 5 to 20 % of the preset threshold. The hysteresis value cannot be higher than the extremes of the measurement range.

In overvoltage mode, if the controlled voltage exceeds the preset threshold for longer than the time set on the front face (0.1 to 10 s), the output relay opens and LED R is extinguished. During the time delay, this LED flashes.

Once the voltage falls below the threshold value minus the hysteresis, the relay closes instantaneously.

In undervoltage mode, if the controlled voltage falls below the preset threshold for longer than the time set on the front face (0.1 to 10 s), the output relay opens and LED R is extinguished. During the time delay, this LED flashes.

Once the voltage rises above the threshold value plus the hysteresis, the relay closes instantaneously.

N°	Legend
1	Threshold
2	Hysteresis
3	Overvoltage function relay
4	Undervoltage function relay
5	Controlled signal
6	Delay on threshold crossing (Tt)

Principles

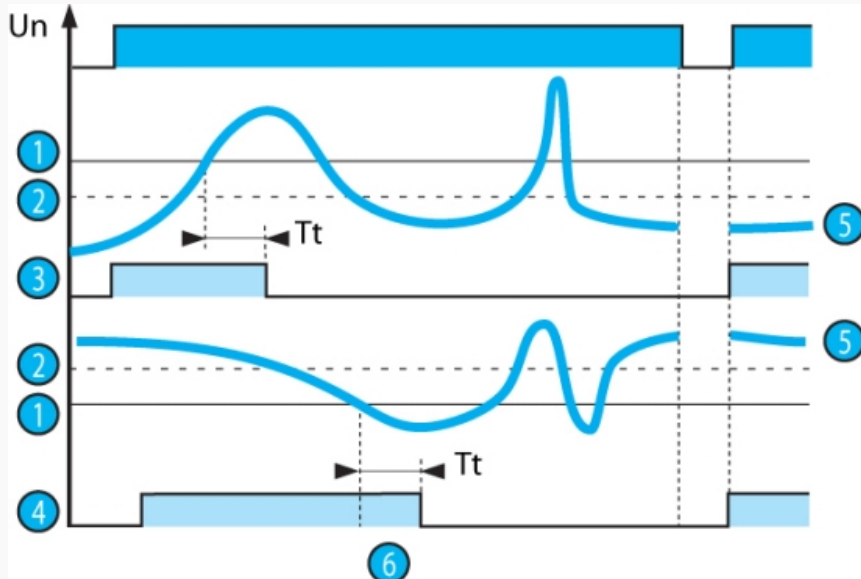

If "with memory" mode has been selected, the relay opens and stays in this position when threshold crossing is detected. The power supply must be disconnected to reset the product.

N°	Legend
1	Threshold
2	Hysteresis
3	Overtoltage function relay
4	Undervoltage function relay
5	Controlled signal
6	Delay on threshold crossing (Tt)

**Dimensions (mm)**

MUS - MUSF

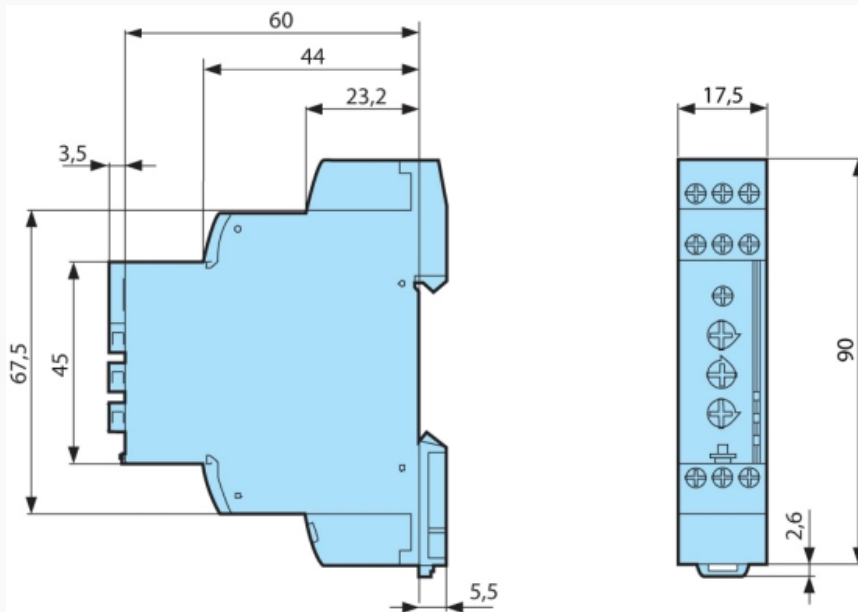

**Connections**

MUS - MUSF

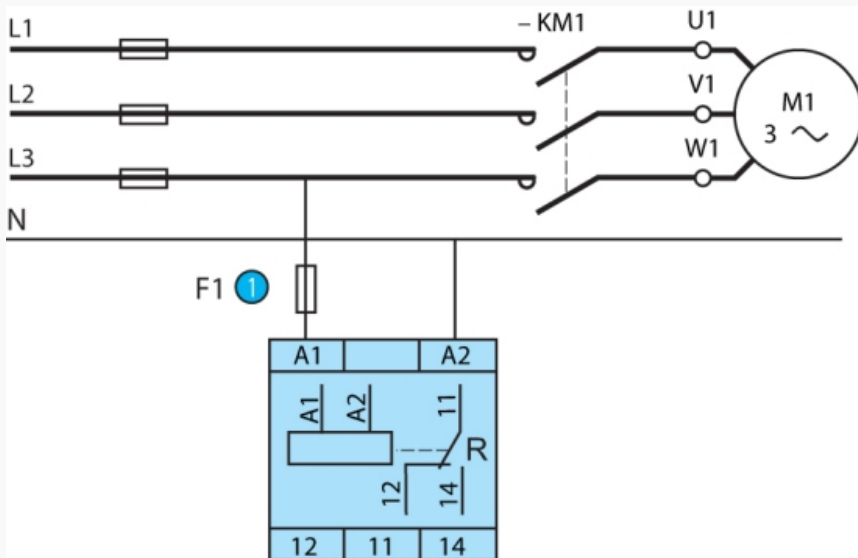

N°	Legend
1	1 A fast-blow fuse or cut-out

**Product adaptations**

- Customisable colours and labels
  - Fixed threshold in the generic measurement range
  - Fixed or adjustable time delay
  - Adjustable hysteresis
- Adaptations dedicated to MUS 12 DC, MUS 80 AC, MUS 260 AC :
- Possible to delete settings
  - Adjustable fixed hysteresis