



**Polymer
Optics
Limited**

Our Focus is in Plastics

Polymer Optics Ltd.

6 Kiln Ride, Wokingham,
Berks., RG40 3JL, England
Tel/Fax: +44 (0) 1189 893341
www.polymer-optics.co.uk

30mm 5 Deg Reflector Collimator for Cree MC-E LED - Part No. 225

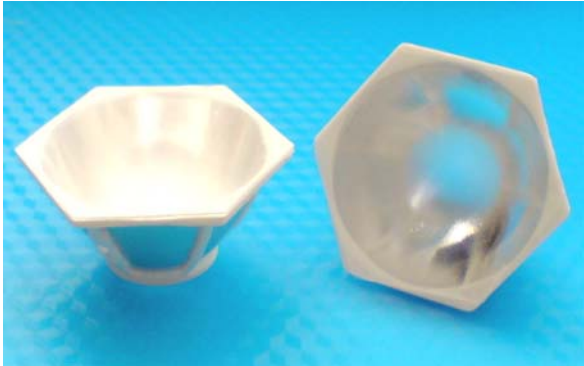

- Designed for Cree MC-E multi-die LED
- High light collection efficiency of >85%
- Precision moulded using POL's patent applied for metallised optical insert moulding technique with a polycarbonate frame construction for superior mechanical and thermal stability
- Also available for other Cree LED package types
- Part of the Polymer Optics "Modular LED Optics"® range

Polymer Optics "Modular LED Optics"® design, based on a hexagonal format, allows maximum packing density and assembly flexibility. Arrays of single colour or colour mixed cells can be easily constructed

The 225 Reflector Optic base is designed to push fit over the Cree MC-E LED package to align to the LED source

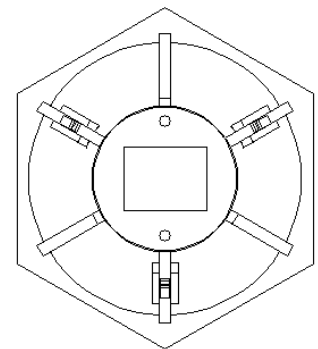
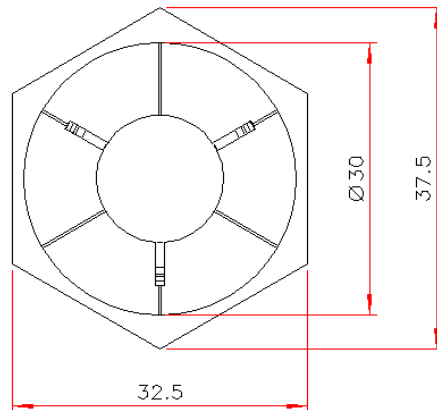

ORIENTATION OF BASE TO 7090 PACKAGE

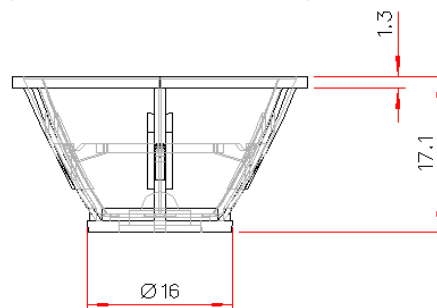

Typical dimensional tolerances to +/-0.2mm



Our Focus is in Plastics

Polymer Optics Ltd.

6 Kiln Ride, Wokingham,
Berks., RG40 3JL, England
Tel/Fax: +44 (0) 1189 893341
www.polymer-optics.co.uk

30mm 5 Deg Reflector Collimator for Cree MC-E LED - Part No. 225



The POL 225 optic's narrow, high intensity beam is ideal for demanding applications, such as:

- ✓ Mining and caving lamps
- ✓ Under water lamps and torches
- ✓ Architectural spot lights (single colour and RGB arrays)
- ✓ Theatrical lights and follow-spots (single colour and RGB arrays)
- ✓ High performance torches
- ✓ High level flood lights
- ✓ Street lights
- ✓ Medical lighting applications

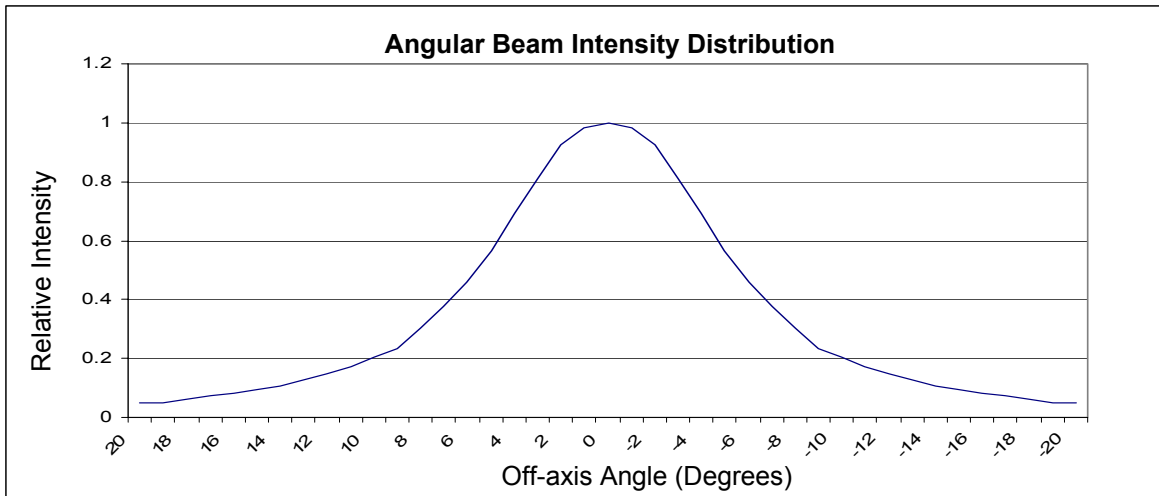

Typical illuminance values using 350 lumen Cree MC-E LED = 7 cd/lumen			
Range	0.5m	1m	2m
Illuminance	9800 lux	2450 lux	612 lux

Performance values given are typical values and will vary dependant on LED binning, colour and drive profile