



Speed Controller

Series

SC 1801

SC 2402

SC 2804

SC 5004

SC 5008

Instruction Manual

EN

Imprint

Version:
6th issue, 18.10.2013

Copyright
by Dr. Fritz Faulhaber GmbH & Co. KG
Daimlerstr. 23/25 · 71101 Schönaich

All rights reserved, including those to the translation.
No part of this description may be duplicated, reproduced, stored in an information system or processed or transferred in any other form without prior express written permission of Dr. Fritz Faulhaber GmbH & Co. KG.

This technical manual has been prepared with care.
Dr. Fritz Faulhaber GmbH & Co. KG cannot accept any liability for any errors in this technical manual or for the consequences of such errors. Equally, no liability can be accepted for direct or consequential damages resulting from improper use of the equipment.

The relevant regulations regarding safety engineering and interference suppression as well as the requirements specified in this technical manual are to be noted and followed when using the software.

Subject to change without notice.

The respective current version of this technical manual is available on FAULHABER's internet site:
www.faulhaber.com

Table of Contents

1	Important Information	5
1.1	Symbols used in this technical manual	5
1.2	Safety instructions	6
1.3	Documentation	7
1.4	Ambient conditions	7
1.5	Servicing/maintenance	7
1.6	Troubleshooting	7
2	Description	8
2.1	Product information	8
2.2	General product description	10
3	Installation	12
3.1	Assembly	12
3.2	EMC compatible installation	13
3.2.1	Description of the EMC measures	13
3.3	Connector pin assignment	16
3.4	Connection functions	17
3.5	Quick start	21
3.5.1	Connection examples for the supply end	21
3.5.2	Connection examples for the motor end	22
4	Configuration	24
4.1	Configuration for DC motors	25
4.1.1	DC motors with encoders	25
4.1.2	DC motors without encoders (not SC5004/SC5008)	26
4.2	Configuration for BL motors	28
4.2.1	BL motors with digital hall sensors	28
4.2.2	BL motors with analog hall sensors	30
4.2.3	BL motors without hall sensors (sensorless operation) (not SC5004/SC5008)	31
4.2.4	BL Motors with absolute encoder (AES-64/AES-4096)	33
4.2.5	BL motors with digital Hall sensors and incremental encoder IE2	34
4.3	Special Configurations	35
4.3.1	Speed setpoint input via PWM signal	35
4.3.2	Operation with fixed speed (fixed speed mode)	36
4.3.3	Operation as voltage controller (volt mode)	36
4.3.4	Digital output (FG)	36
4.4	Parameter settings	37
4.4.1	Motor constants	37
4.4.2	Current limiting values	37
4.4.3	Fixed speed value	37

Table of Contents

4.4.4	Pulses per motor revolution	38
4.4.5	Maximum speed value	38
4.4.6	Controller parameter	39
4.4.7	encoder resolution	39
4.4.8	Starting time (for BL motors in sensorless operation only)	39
4.4.9	Minimum speed (for BL motors in sensorless operation only)	40
4.4.10	Delayed Current Error (with error output only)	40
4.5	Technical information	41
4.5.1	I ² t current limiting	41
4.5.2	Overtemperature cut-off	42
4.5.3	Adjusting the controller parameters	42
4.5.4	Effect of pulse width modulation (PWM)	42
5	Operation	44
5.1	Startup	44
6	EC Product Safety Directives	45
7	Warranty	46
8	Index	47

1 Important Information

The handling and technical features of FAULHABER external speed controllers are described in this instruction manual.

- Please read the complete instruction manual before using the controller.
- Keep this instruction manual in a safe place for subsequent use.

The information given in this instruction manual refers to the standard versions of the speed controller. Please refer to any additional information sheet provided in the event of differences in information due to a customer-specific modification.

1.1 Symbols used in this technical manual

WARNING!



Warning!

This pictogram with the wording "Warning!" indicates an imminent danger which can result in physical injuries.

- ▶ *This arrow points out the appropriate action to take to prevent the imminent danger.*

CAUTION!



Caution!

This pictogram with the wording "Caution!" indicates an imminent danger which can result in slight physical injuries or material damage.

- ▶ *This arrow points out the appropriate precautions.*

REGULATION!



Regulations, guidelines and directives

This pictogram with the wording "Regulation" indicates a statutory regulation, guideline or directive which must be observed in the respective context of the text.

NOTE



Note

This "Note" pictogram provides tips and recommendations for use and handling of the component.

1 Important Information

1.2 Safety instructions

Observance of the following safety instructions is prerequisite for trouble-free and safe operation of the speed controllers. Therefore, please carefully read through all the notes and follow them when using the controllers.

Intended use

FAULHABER speed controllers are designed for the driving and speed control of DC and BL motors in the low (SC1801), mid (SC2402/SC2804) and higher power range (SC5004 / SC5008).

The speed controllers' control parameters can be individually adjusted to the respective application via a PC. This requires a programming adapter, which can be ordered separately, as well as a version of the FAULHABER Motion Manager PC software suitable for the speed controllers. The software is available on request or from the FAULHABER homepage <http://www.faulhaber.com>.

- The speed controllers contain electronic components and are to be treated according to the ESD regulations.
- The speed controllers may not be used in environments where contact with water, chemicals and / or dust is possible or in potentially explosive atmospheres.
- The inertia of the motors operated at the speed controllers may not be noticeably increased by the motor load.
- The speed controllers are not suitable for reversing operation.
- The housings of the SC1801S and SC1801F speed controllers are not solvent resistant and must not come into contact with certain solvents (see [Chapter 1.4 "Ambient conditions"](#)) or substances containing solvents.
- Please ask the manufacturer for information about individual use under special ambient conditions.

The following motor types can be operated with the speed controllers:

- DC motors with incremental encoders.
- DC motors without encoders (not SC5004/SC5008).
- BL motors with digital hall sensors.
- BL motors without hall sensors (sensorless operation) (not SC5004/SC5008).
- BL motors with absolute encoders (e.g. AES-4096).
- BL motors with analog hall sensors.
- BL motors with digital hall sensors and encoders.

1 Important Information

1.3 Documentation

The following table gives an overview of the documentation of the FAULHABER electronic products described in this instruction manual:

Products Series	Data sheets						Instruction manuals
	SC Function	SC1801	SC2402	SC2804	SC5004	SC5008	Speed Controller (MA05024)
SC1801P	X	X					X
SC1801S	X	X					X
SC1801F	X	X					X
SC2402P	X		X				X
SC2804S	X			X			X
SC5004P	X				X		X
SC5008S	X					X	X

The documentation is available on request or from the FAULHABER internet site (www.faulhaber.com).

1.4 Ambient conditions

CAUTION!



Chemicals

The housings of the SC1801S and SC1801F speed controllers are only conditionally resistant to solvents such as methylated spirits and acetone.

- ▶ In operation the housings must be protected against contact with solvents or substances containing substances.

NOTE



Software

The speed controller firmware can be reprogrammed at least 20 000 times.

1.5 Servicing / maintenance

The speed controllers are designed to be maintenance-free. No maintenance measures are necessary.

1.6 Troubleshooting

Due to their design, if the parameters given in this instruction manual are complied with the speed controllers are trouble-free. Should a malfunction occur in spite of this please contact the manufacturer.

Head office: +49(0)7031/638-0

E-Mail: info@faulhaber.de

Internet: www.faulhaber.com

2 Description

2.1 Product information

The product's most important technical data can be determined from the product name. The structure and significance of the product names are described in the following overview:

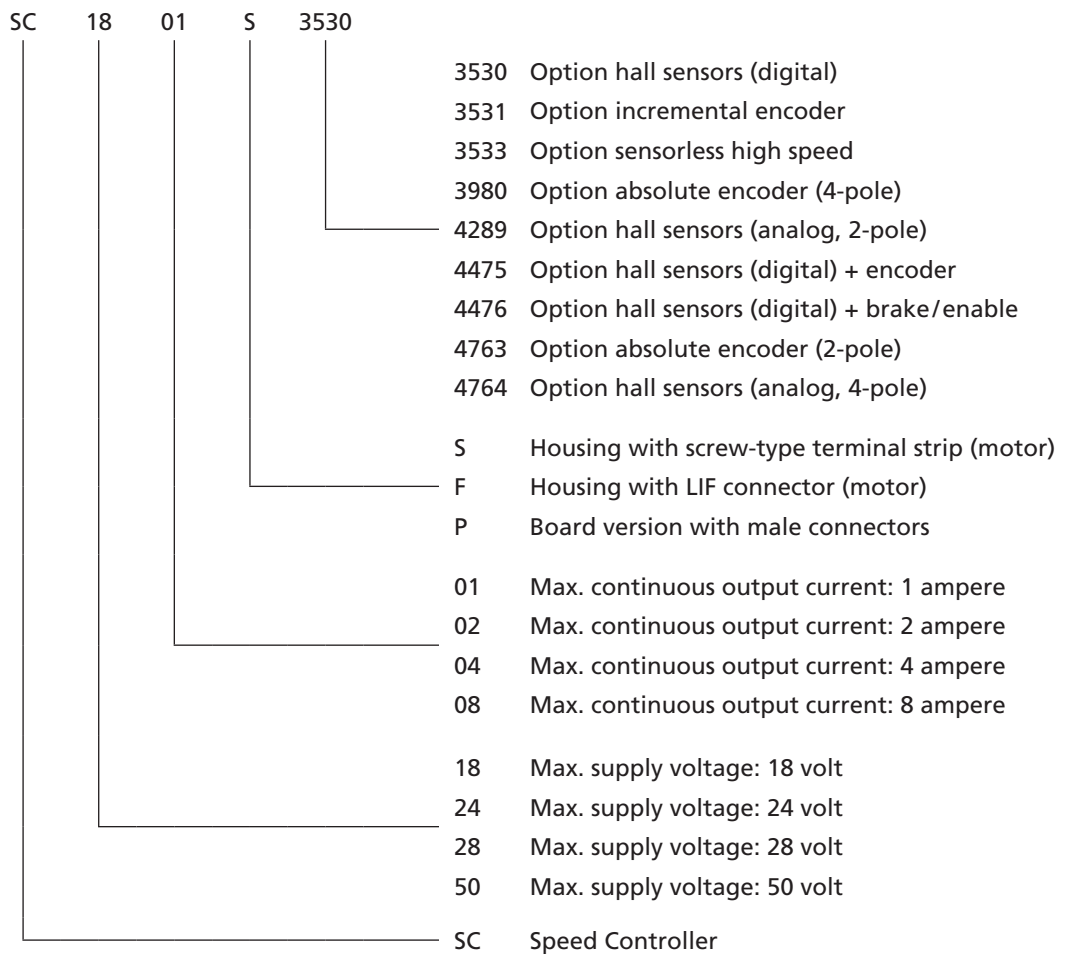

2 Description

2.1 Product information

Steuerung		Default function										
Name	Type	Variant	BL Hall sensors digital	BL Hall sensors analog	BL AES encoder 4096	BL AES encoder 256	BL Digital Hall + Inc. encoder	BL Digital Hall + enable	BL Sensorless normal	BL Sensorless high-speed	DC + Inc. encoder	Sensorless
SC 1801	S	3530	■									■
SC 1801	S	3531										
SC 1801	S	3980/4763		■	■						■	
SC 1801	S	4289/4764		■	■							
SC 1801	F	3533	■							■		
SC 1801	F	3980/4763		■	■							
SC 1801	F	4289/4764		■	■							
SC 1801	P	3530	■									
SC 1801	P	3531										
SC 1801	P	3980/4763		■	■							
SC 1801	P	4289/4764		■	■							
SC 2402	P	3530	■									
SC 2402	P	3531										
SC 2402	P	4475					■					
SC 2402	P	4476					■					
SC 2402	P	3980/4763		■	■							
SC 2402	P	4289/4764		■	■							
SC 2804	S	3530	■									
SC 2804	S	3531										
SC 2804	S	4475					■					
SC 2804	S	4476					■					
SC 2804	S	3980/4763		■	■							
SC 2804	S	4289/4764		■	■							
SC 5004	P	3530	■									
SC 5004	P	3531										
SC 5004	P	4475					■					
SC 5004	P	4476					■					
SC 5004	P	3980/4763		■	■							
SC 5004	P	4289/4764		■	■							
SC 5008	S	3530	■									
SC 5008	S	3531										
SC 5008	S	4475					■					
SC 5008	S	4476					■					
SC 5008	S	3980/4763		■	■							
SC 5008	S	4289/4764		■	■							

- As-delivered condition
- Reconfiguration possible with Motion Manager and programming adapter

2 Description

2.2 General product description

FAULHABER speed controllers are based on an integrated microcontroller and are used to control the speed of the motor types listed in [Chapter 1.2 "Safety instructions"](#).

The speed controller product family consists of the following products:

Speed controller for motors in the low power range

■ SC1801S

Speed controller with housing and screw-type terminal strips on the supply and motor end.

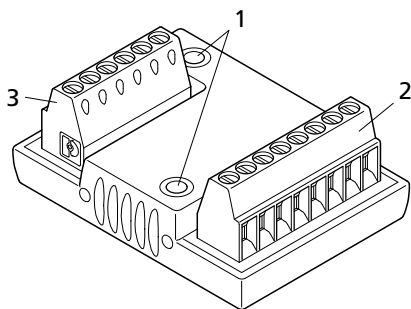

- 1 Fixing sockets
- 2 Screw-type terminal strip, motor end
- 3 Screw-type terminal strip, supply end

■ SC1801F

Speed controller with housing, screw-type terminal strip on the supply end and flexboard connection on the motor end.

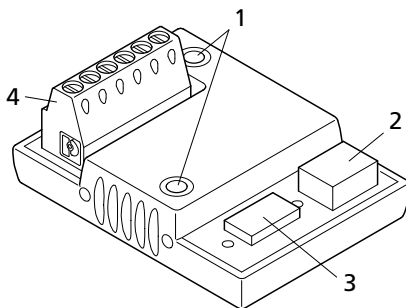

- 1 Fixing sockets
- 2 LIF connector motor end for FFC and FPC, 3-pole
- 3 LIF connector motor end for FFC and FPC, 8-pole
- 4 Screw-type terminal strip, supply end

■ SC1801P

Speed controller without housing (board version) with pin headers on the supply and motor end

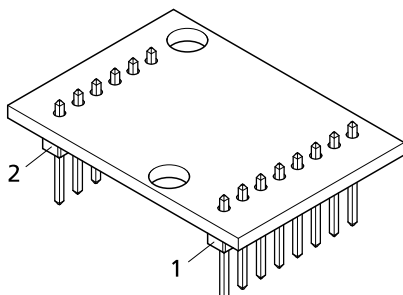

- 1 Pin header, motor end
- 2 Pin header, supply end

2 Description

2.2 General product description

Speed controller for motors in the mid and higher power range

■ SC2804S/SC5008S

Speed controller with metal housing and screw-type terminal strips on the supply and motor end.

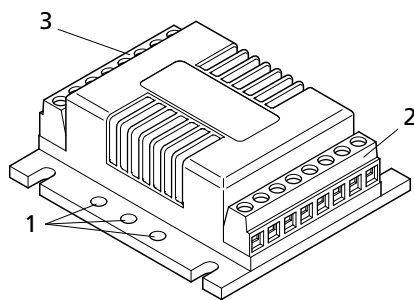

- 1 Mounting threads
- 2 Screw-type terminal strip, motor end
- 3 Screw-type terminal strip, supply end

■ SC2402P/SC5004P

Speed controller without housing (board version) with pin headers on the supply and motor end.

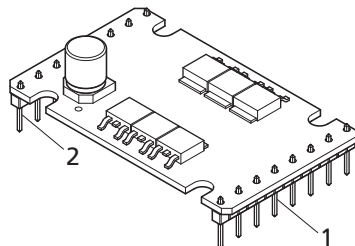

- 1 Pin header, supply end
- 2 Pin header, motor end

Functions

The speed controllers have the following functions for controlling the motors:

- Speed control through setpoint input via an analog voltage.
- Speed control through setpoint input via a PWM signal.
- Operation with fixed speed.
- Operation as voltage controller.
- Current limiting.
- Direction of rotation change via switch input.
- Digital output, configurable as error or frequency output.
- Configuration and parameter assignment through firmware download.

Areas of use

Due to their compact design the speed controllers can be used in diverse applications with little wiring effort. The flexible interfacing possibilities open up a wide range of uses in all areas, for example in decentralised automation technology systems, in handling and tool machines as well as in pump drives.

3 Installation

3.1 Assembly

CAUTION!



Risk of damage

Incorrect assembly or assembly with the wrong fixing materials can cause damage to the speed controllers.

- *Observe the following assembly instructions.*

Off load

The speed controller must be disconnected from the power supply for all types of assembly and connection work.

ESD protection

The regulations for handling modules at risk from ESD must be observed.

Surface

The speed controllers may be screwed onto flat, hard surfaces only. The surface must be suitable for supporting the assembly sleeves against the screwing forces. Screwing onto a soft or uneven surface can cause the assembly sleeves to be pressed out.

Correct

The speed controller is mounted on a flat, hard surface.

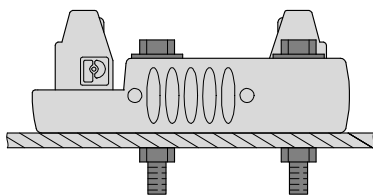

Incorrect

The speed controller is screwed on over an edge. Risk of pushing out the assembly sleeves!

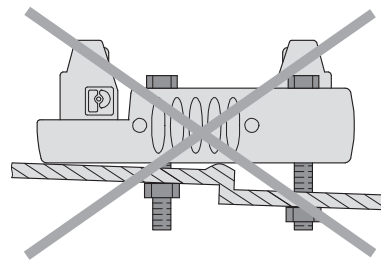

Screw-type terminal strips

The maximum tightening torque of the screw-type terminal strips must be noted and observed.

For series SC1801 S: 0.12 ... 0.15 Nm

For series SC2804 / 5008 S: 0.5 ... 0.6 Nm

Flexboard connector

The motors' flexboards must be inserted into the connector flat. The connector pin assignment and connection symbols must be noted.

Never press the flexboard into the connector with force as this could damage it. If necessary, use a suitable tool (for example, tweezers or a flat-nose pliers). Ensure the flexboard is not squeezed or crushed.

3 Installation

3.2 EMC compatible installation

CAUTION!



Length of the connection leads

The maximum length of the connection leads is limited.

- ▶ All connection leads may not exceed a length of 3 m.
- ▶ Note and follow further information on the motor connection leads in the following.

Optimisation of the performance with respect to unwanted emissions and immunity requires additional EMC measures:

- Ensuring allowable emissions or necessary immunity in industrial use may require the use of an EMC filter and/or an EMC suppressor circuit.

Speed Controller	Use environment	Interference type	Action
SC1801	Industrial use	Immunity	EMC suppressor circuit
SC2804/SC5008	Industrial use	Emission	EMC filter
		Immunity	EMC suppressor circuit

This table shows which additional EMC measures can be implemented to optimise the performance of the equipment in its intended environment with respect to unwanted emissions and immunity.

The units are intended for industrial use only. If the units are used for residential, retail, commercial purposes or in a small company, suitable measures must be taken to ensure that the emission is below the allowable limit value.

3.2.1 Description of the EMC measures

The EMC filter

The electronics and motor supply cables must be laid directly on the unit, each with two turns through a suitable ferrite sleeve (e.g. Würth Elektronik No.: 74270090).

For DC motors with encoders the signal cables must be laid directly on the unit on both connection sides with one turn through one Star-TEC each (e.g. Würth Elektronik No.: 74271132).

3 Installation

3.2 EMC compatible installation

The EMC suppressor circuit

Circuit diagram 1

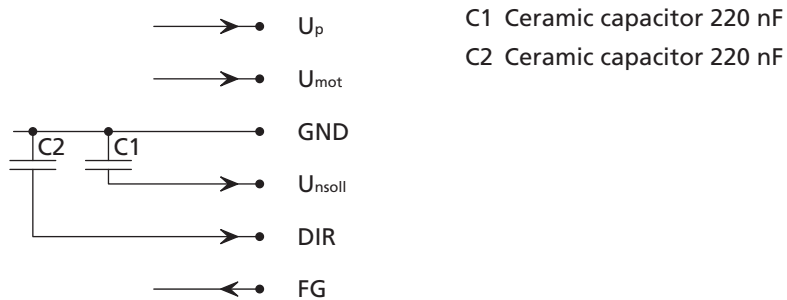

NOTE



Capacitor C1:

If the ceramic capacitor C1 is used, malfunctions can occur in PWMnsetpoint operating mode.

- Use signal source with low internal resistance in PWMnsetpoint operating mode.

NOTE



Capacitor C2:

If using the ceramic capacitor C2, a firmware update with the Motion Manager PC firmware may no longer be possible.

- Remove the C2 capacitor when updating the firmware.

3 Installation

3.2 EMC compatible installation

Circuit diagram 2 (SC1801)

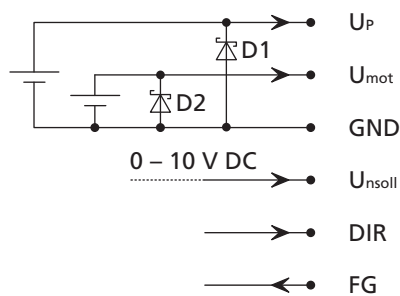

Separate suppressor diodes (D1, D2) for U_P and U_{mot} if they have separate supply voltages.

If only one supply voltage is used, (bridge between U_P and U_{mot}), one suppressor diode (D1) is sufficient.

D1 and D2 e.g. P6KE18 from ST Microelectronics.

Circuit diagram 3 (SC2804 / SC5008)

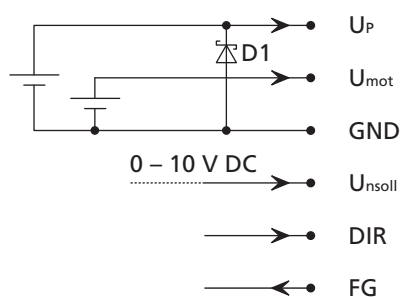

The suppressor diode D2 at U_{mot} is integrated in the controller. If a joint supply voltage is used (bridge between U_P and U_{mot}), this is sufficient. If separate supply voltages are used, an additional external suppressor diode (D1) is recommended at U_P .

Examples:

U_P 24 V: D1 = P6KE33A

U_P 48 V: D1 = P6KE56A

NOTE



Exceptions:

It may not be necessary to implement the additional EMC measures named. If the controller is fed e.g. from a CE-conforming power supply unit which firstly is connected with the controller by the shortest possible connection lead and secondly no other devices are supplied, then the EMC filter or EMC suppressor circuit (circuit diagram 3) can be dispensable. In this case the power supply unit takes on the function of the EMC filter or the EMC suppressor circuit according to circuit diagram 3.

The same applies accordingly to the EMC suppressor circuit according to circuit diagram 2:

The EMC suppressor circuit can be dispensable if other design measures prevent emissions from interfering with the control voltage for the desired speed and the switch input for the direction of rotation.

3 Installation

3.3 Connector pin assignment

Depending on their type, the speed controllers are equipped with either screw-type terminal strips, flexboard connectors or pin headers as connection options.

CAUTION!



Electronic damage /ESD protection

Electrostatic discharges at the speed controller's connections can cause damage to or destruction of the electronics.

- ▶ Note and follow the ESD protective measures.

Incorrect connection of the strands can cause damage to or destruction of the electronics.

- ▶ Connect the connections in accordance with the connector pin assignment, see table.

Please also note and follow the supplementary installation instructions in [Chapter 6 "EC Product Safety Directives"](#).

Connector pin assignment, supply end

Connection	Function	Meaning
1	Up	Electronic supply
2	U _{mot}	Coil supply
3	GND	Ground
4	U _{nsoll}	Default speed setpoint
5	DIR	Switch input for the motor's direction of rotation
6	FG	Digital output
7	IO2	encoder or enable (only with appropriate hardware, not SC1801)
8	IO1	encoder or brake (only with appropriate hardware, not SC1801)

Connector pin assignment, motor end

Connection	Function	BL Motors	DC Motors
9	Mot C	Motor Phase C	Reserved
10	Mot B	Motor Phase B	Motor -
11	Mot A	Motor Phase A	Motor +
12	SGND	Signal GND	Signal GND
13	U _{DD}	Sensor supply	encoder supply
14	Sens C	Hall sensor C/Absolute encoder CLK	encoder Channel B
15	Sens B	Hall sensor B/reserved	encoder Channel A
16	Sens A	Hall sensor A/Absolute encoder DATA	

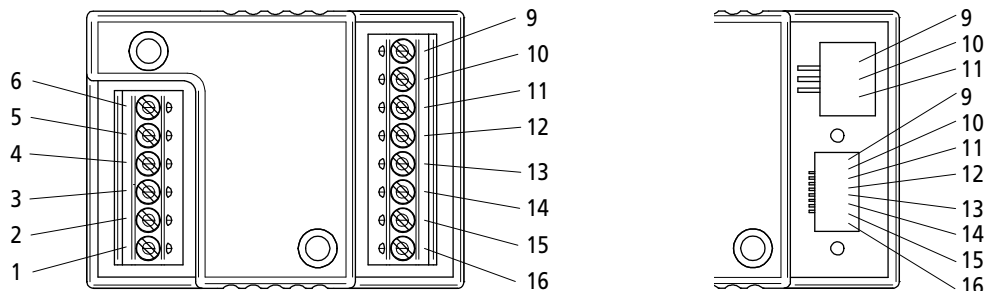

CAUTION!



Malfunction

If a motor connection cable longer than 30 cm is used malfunctions can occur during operation.

- ▶ Use motor connection cables with a maximum length of 30 cm only for the speed controller.
- ▶ The possibility of using a longer connection cable must be checked on a case by case basis!

3 Installation

3.4 Connection functions

Depending on their type, the speed controllers are equipped with either screw-type terminal strips, an LIF interface or pin headers as connection options.

U_P (Connection 1)

Supply voltage for the electronics.

Voltage: See product data sheet.

U_{mot} (Connection 2)

Supply voltage for the motor or the power output stage.

Voltage: See product data sheet.

CAUTION!



Overvoltage!

In braking operation the connected motor can act as a generator. U_{mot} can therefore rise uncontrolledly.

- ▶ *Power supply units and any other peripheral components must be designed accordingly. Use of the FAULHABER brake chopper BC 5004 is recommended to protect the connected peripheral components.*

GND (Connection 3)

Joint ground for U_P and U_{mot}.

NOTE



Power supply unit

The U_P and U_{mot} connections can be supplied from the same power supply unit. In this case it is necessary to ensure that the power supply unit's output is adequate for supplying power to the speed controller and to the connected motor.

U_{nsoll} (Connection 4)

Input, speed setpoint.

The Unsoll input can be configured in different ways (see [Chapter 4 "Configuration"](#)):

Speed setpoint input via analog voltage (standard as delivered condition)

Voltage range: 0 ... 10 V DC (no speed setpoint is defined for > 10 V DC ... max. U_P).

- Motor stops at U_{nsoll} < 0.15 V.
- Motor runs at U_{nsoll} > 0.3 V (0.5 V for BL motors in sensorless operation).
- The setpoint speed is proportional to the voltage U_{nsoll}. The maximum setpoint speed at 10 V can be configured. See [Chapter 4.4.5 "Maximum speed value"](#).

Speed setpoint input via PWM signal

PWM frequency range: 500 Hz – 18 kHz.

- Motor stops at pulse duty factor < 2.0 %.
- Motor runs at pulse duty factor > 3.0 %.
- The setpoint speed is proportional to the pulse duty factor. The maximum setpoint speed at 100 % can be configured. See [Chapter 4.4.5 "Maximum speed value"](#).
- The TTL and PLC levels can be configured as switching levels:

Mode	high level	low level
TTL*	> 3.0 V DC	< 0.5 V DC
PLC	> 7.5 V DC	< 2.0 V DC

*not for SC5004/SC5008

3 Installation

3.4 Connection functions

Quick stop input (low level)

Input is only used to stop the motor.

- Motor stops at $U_{\text{nsoll}} < 0.15 \text{ V}$.
- Motor stops if connection is open.
- Motor runs at $U_{\text{nsoll}} > 0.3 \text{ V}$ (0.5 V for BL motors in sensorless operation).

Quick stop input inverted (high level)

Input is only used to stop the motor.

- Motor runs at $U_{\text{nsoll}} < 2.0 \text{ V}$.
- Motor runs if connection is open.
- Motor stops at $U_{\text{nsoll}} > 2.4 \text{ V}$.

No function

In this setting the input is deactivated.

NOTE



Input resistance

The input resistance of the U_{nsoll} connection differs depending on the configuration. The lowest value is $\geq 5 \text{ k}\Omega$.

DIR (Connection 5)

Switch input for the motor's direction of rotation.

CAUTION!



Risk of damage

Switching over the motor's direction of rotation (reversing duty) too quickly can cause damage. Reversing the polarity while the motor is rotating results in excessively high currents in the output stage, and the output stage can be overloaded as a result. A rotating mass connected to the motor amplifies this effect!

► *Do not use the speed controller for reversing duty.*

- Direction of rotation clockwise if connection $> 3 \text{ V DC}$; max. U_{p} .
- Direction of rotation clockwise if connection open (is internally set to high level). Note and observe [Chapter 3.2 "EMC compatible installation"](#) if input open.
- Direction of rotation anti-clockwise if connection $< 0.5 \text{ V DC}$.
- Direction of rotation anti-clockwise if connected to ground.

3 Installation

3.4 Connection functions

FG (Connection 6)

Digital output.

The digital output is a switch which switches to GND (open collector with integrated pull-up resistance).

Output voltage: max. U_P .

Output current: max. 15 mA.

The digital output can be configured for different tasks:

Error output

Only possible configuration for DC motors.

- Output switches to high level if current limiting is activated. The delay between activation of current limiting and activation of the output can be adjusted. See [Chapter 4.4.10 "Delayed Current Error \(with error output only\)"](#).
- Output switches to low level if current limiting is deactivated.

Frequency output

Frequency output for reading out the actual motor speed. Only possible configuration for BL motors in sensorless operation. As delivered condition for BL version.

Signal setup: 3 pulses per motor revolution.

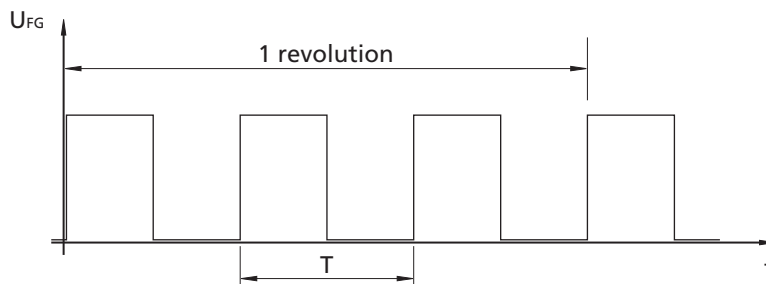

NOTE



Pull-up resistance

An additional, external pull-up resistance can be connected to increase the edge steepness. The maximum loadability of the digital output must be noted and observed. See circuit diagram:

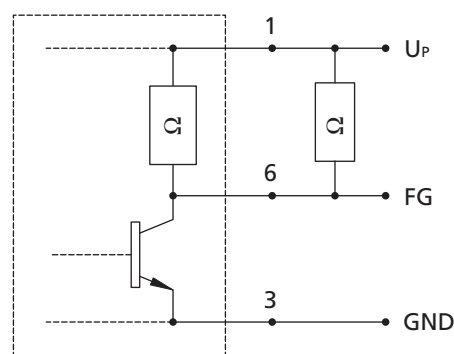

Due to the coupling of the internal pull-up resistance between FG and the supply voltage U_P , conducted electromagnetic RF interference, which affect the supply voltage, can drastically worsen the FG signal.

If operated properly and as intended, the speed and direction of rotation of the motor are not impaired by this interference.

3 Installation

3.4 Connection functions

IO1 / IO2 (Connections 7 – 8)

Depending on the hardware (not SC1801):

- reserved
- encoder A/B digital input for speed determination for BL motors with digital Hall sensors
- brake/enable for activation/deactivation of BL motors with digital Hall sensors

Mot C – Mot A (Connections 9 – 11)

Supply connections for motor winding.

BL Motors

During the operation of brushless motors the motor phases are directly controlled via the Mot A, Mot B and Mot C connections.

DC Motors

During the operation of DC motors the motor winding is supplied via the Mot B (-) and Mot A (+) connections.

SGND (Connection 12)

Joint ground of the hall sensors, or the encoder.

V_{CC} (Connection 13)

Joint power supply of the hall sensors, or the encoder.

Maximum output current (I_{CC}): See product data sheet.

Sens C – Sens A (Connections 14 – 16)

Inputs of the hall sensor or encoder signals.

3 Installation

3.5 Quick start

Full drive (motor speed is determined by U_{mot})

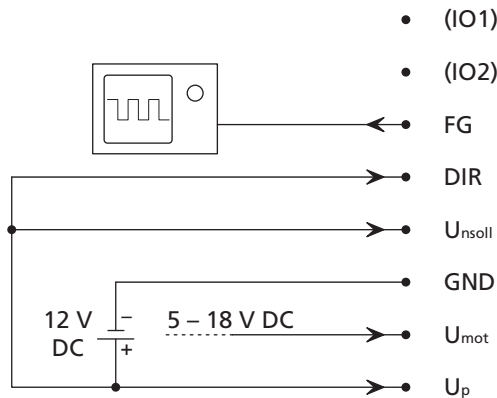

The connected motor rotates with load-dependent speed in a clockwise direction. The speed can be adjusted by changing U_{mot} . If the digital output is configured as a frequency output the speed signal can be measured there.

3.5.2 Connection examples for the motor end

DC motor with encoder

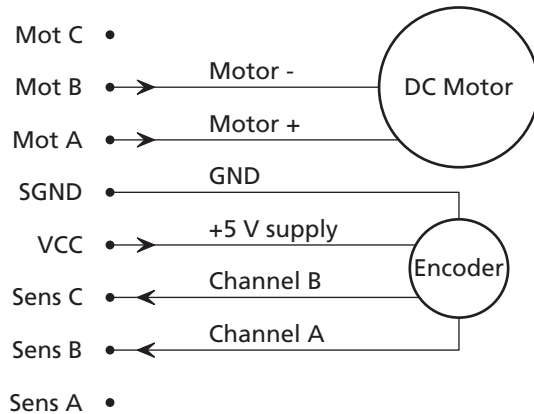

DC motor without encoder (not SC5004/SC5008)

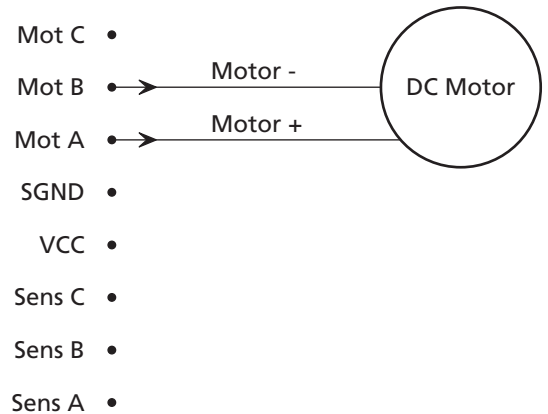

3 Installation

3.5 Quick start

BL motor with digital/analog hall sensors

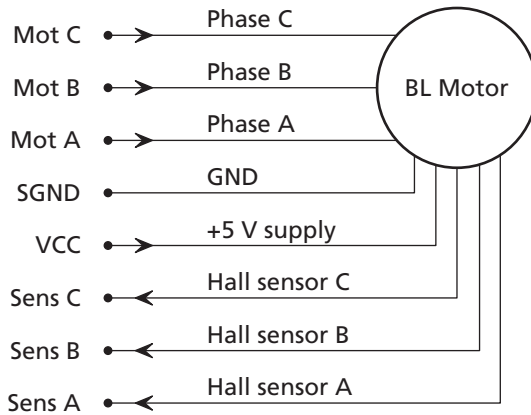

**BL motor without hall sensors
(not SC5004/SC5008)**

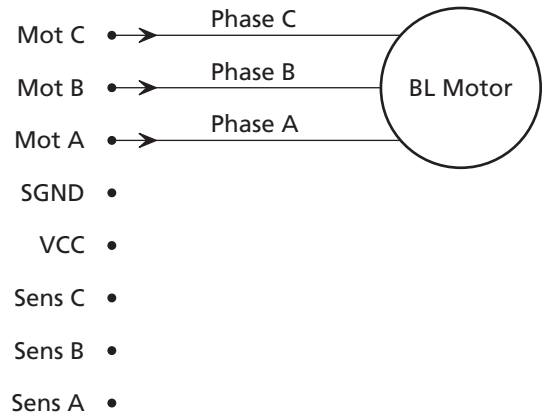

BL motor with absolute encoder

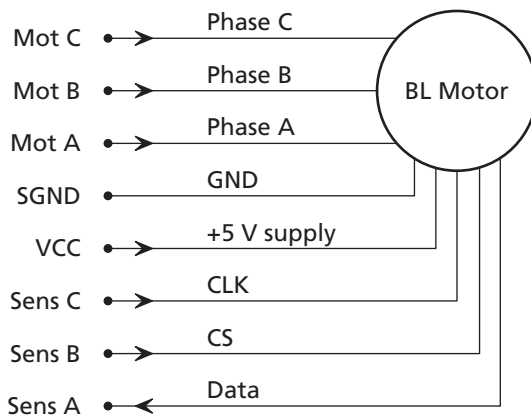

**BL motor with digital hall sensors
and encoder IE 2 (not SC1801)**

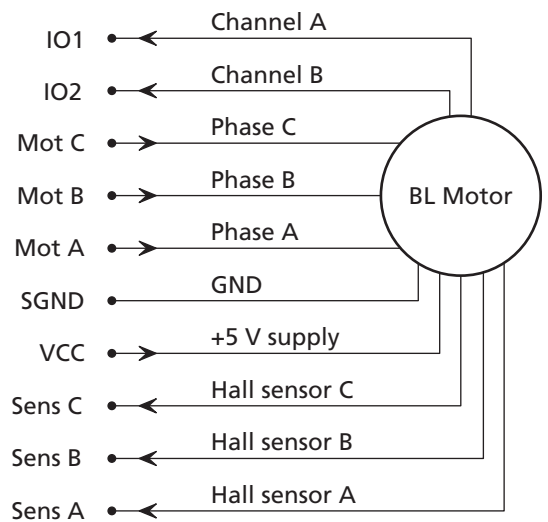

4 Configuration

CAUTION!



Risk of damage

Before starting up, check the parameters configured in the control and if necessary adjust to the connected motor. In particular, the following parameters must be correctly set:

- Motor type (BL/DC motor),
- Duration and maximum current value,
- encoder resolution for motors with encoders,
- Generator voltage constant kE and connection resistance R for DC motors in sensorless operation,
- Controller parameter.

The speed controllers can be configured for different operating modes. In the default configurations the motors are operated with speed control. Actual (instantaneous) speed value determination is necessary for speed control. The various default configurations differ here.

It is also possible to operate the speed controller as a pure voltage regulator. The necessary configuration is described in [Chapter 4.3.3 "Operation as voltage controller \(volt mode\)"](#).

NOTE



The Speed Controllers can be ordered with diverse preconfigured operating modes in accordance with the respective product data sheet.

Customer-specific versions are also available on request.

The speed controllers can be conveniently adjusted to the required function via the graphic interface of the FAULHABER Motion Manager. The parameters and settings are changed by updating the controller firmware via the serial port.

As the speed controllers do not have a command interface, the DIR and FG connections have to be connected to the TxD and RxD conductors of the serial port of a PC via a programming adapter for the configuration.

After the power supply is switched on the controller checks whether certain serial data is received in the conductor and in this case switches to configuration mode, otherwise the regular application is started and the DIR and FG connections are no longer available as a serial port. Therefore, it is only possible to change the configuration directly after switching on. This requires a programming adapter which can be ordered separately.

A precise description of the procedure is given in the instruction manual or use the Online Help for the FAULHABER Motion Manager. The FAULHABER Motion Manager is available on request or on the FAULHABER internet site (www.faulhaber.com).

4 Configuration

4.1 Configuration for DC motors

The actual speed value required for speed control can be determined in different ways. The configurations described in the following mainly differ in this respect.

The digital output is permanently programmed as an error output for operation with DC motors. The precise parameter assignment can be looked up in [Chapter 4.3.4 "Digital output \(FG\)"](#).

4.1.1 DC motors with encoders

In the configuration for DC motors with encoders the motors are operated with speed control. Here an incremental encoder is used as the speed actual value detector; it must be built onto or integrated in the motor.

Default basic parameters in this configuration:

- Determination of the actual speed value via the quadrature signals of the connected incremental encoder.
- Dual slope evaluation without direction of speed detection.
- Direction of rotation is defined via the direction of speed input.
- PWM frequency at the power output stage: approx. 96 kHz.
- 2-quadrant operation with function for quick speed reduction: The motor is short-circuited for faster transition from higher to lower speeds (not for SC5004/SC5008).
- Speeds from approx. 100 rpm can be stably and constantly controlled.
- If using the SC5004/SC5008 control, the fastest possible braking is carried out, taking into account the allowed motor current.

Block diagram:

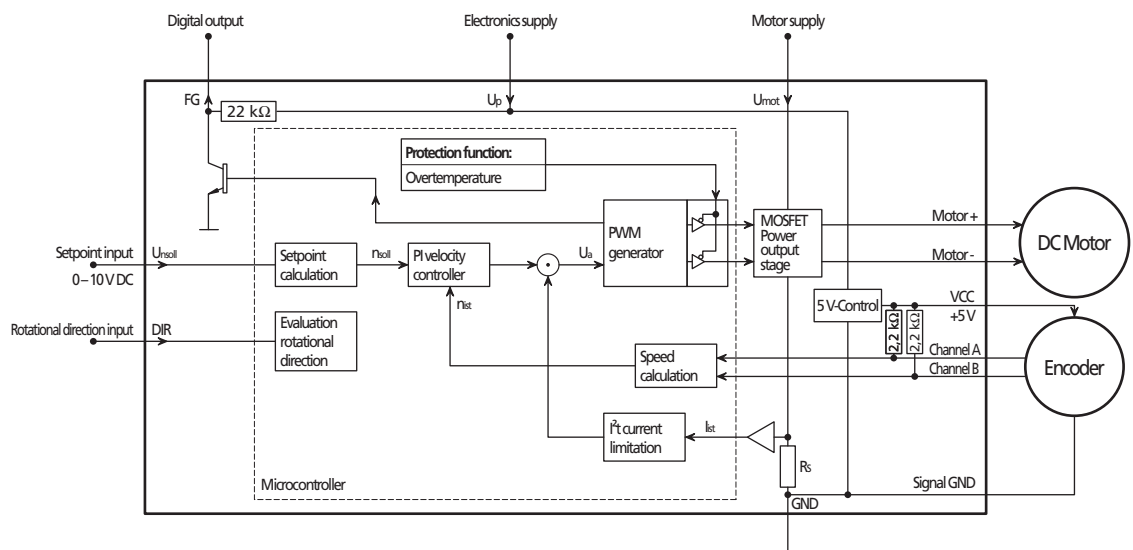

4 Configuration

4.1 Configuration for DC motors

Setting options

- Limited 4-quadrant operation for low speeds.

It is possible to switch to limited 4-quadrant operation for improved control of lower speeds. The speed is then controlled by opposite application of the voltage (braking operation) if the load changes.

NOTE



Braking operation

Sound can be generated in braking operation, caused by the controller's sampling rate.

- Filtering of the speed signal.

It is possible to activate filtering, above all for encoders with low to medium resolution. This reduces any noises and increases the controller's stability. Whether filtering is advantageous for the operation or not depends on the respective application.

- Speed setpoint input via PWM signal at the speed setpoint input. See [Chapter 4.3 "Special Configurations"](#).
- Operation with fixed speed (fixed speed mode). See [Chapter 4.3.2 "Operation with fixed speed \(fixed speed mode\)"](#).
- Operation as voltage controller (volt mode). See [Chapter 4.3.3 "Operation as voltage controller \(volt mode\)"](#).

4.1.2 DC motors without encoders (not SC5004 / SC5008)

In the configuration for DC motors without encoders the motors are operated with speed control. Here the actual speed value required for speed control is determined using "sensorless" methods:

- Counter-EMF (back-induced voltage):

Under a low load or low modulation of the output PWM the counter EMF of the motor is evaluated with the PWM in the switched off state. This requires adjusting the generator voltage constant k_E to the connected motor.

- IxR compensation:

Method for determining the speed at a higher load or higher modulation. The motor speed is determined via an internal motor model. For this the generator voltage constant k_E and connection resistance R matching the connected motor must be set.

4 Configuration

4.2 Configuration for BL motors

The actual speed value required for speed control can be determined using the signals used for commutation. The configurations described in the following mainly differ in this respect.

The default configuration of the digital output for operation with BL motors is as a frequency output.

4.2.1 BL motors with digital hall sensors

In the configuration for BL motors with digital hall sensors the commutation signal is determined via the hall sensor signals. The actual speed value is determined via the time interval between the edges of the hall sensor signals.

Default basic parameters in this configuration:

- Due to the resolution of the digital hall sensors, speeds from approx. 500 rpm can be stably controlled. In 4-pole motors stable control from approx. 250 rpm is possible.
- PWM frequency at the power output stage: approx. 96 kHz.
- 2-quadrant operation with function for quick speed reduction: The motor is short-circuited for faster transition from higher to lower speeds.
- Maximum possible speed for 2-pole motors: 100 000 rpm.
- If using the SC5004/SC5008 control, the fastest possible braking is carried out, taking into account the allowed motor current.

Block diagram:

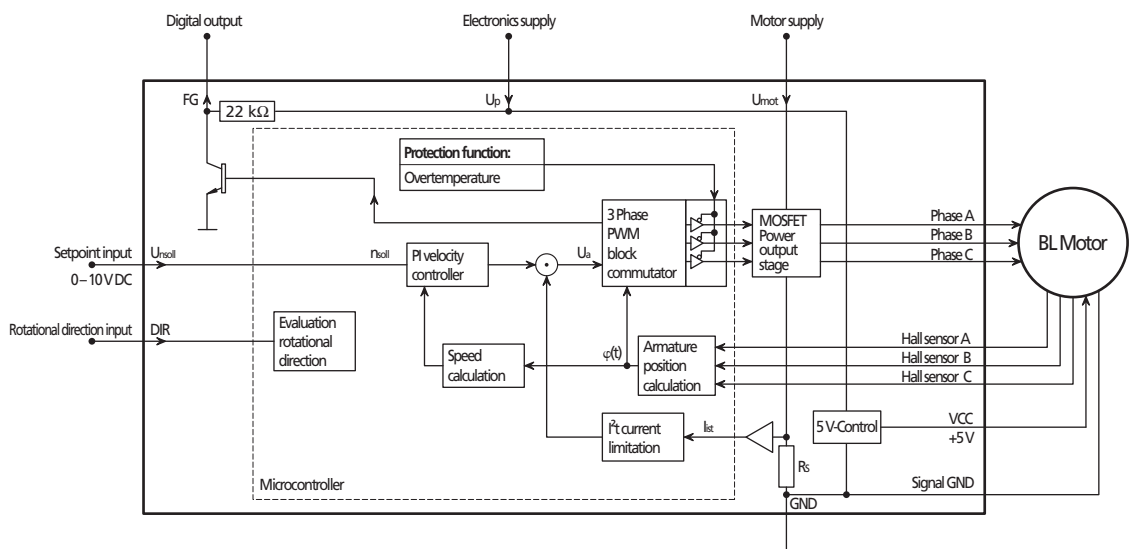

4 Configuration

4.2 Configuration for BL motors

Setting options

- Pure 2-Quadrant operation without active braking option.
- If problems occur during operation with the braking function in the default setting it can be deactivated.
- Filtering (averaging) of the hall sensor signals.
If problems occur with the default setting the time of a complete motor revolution is evaluated to obtain a continuous speed signal. This can cause instable motor running at low speeds as the control dynamics worsen.
- Configuration of the digital output as error output.
- Frequency output can be configured to 1 or 3 pulses per revolution.
- Speed setpoint input via PWM signal at the speed setpoint input See [Chapter 4.3 "Special Configurations"](#).
- Operation with fixed speed (fixed speed mode). See [Chapter 4.3.2 "Operation with fixed speed \(fixed speed mode\)"](#).
- Operation as voltage controller (volt mode). See [Chapter 4.3.3 "Operation as voltage controller \(volt mode\)"](#).

4 Configuration

4.2 Configuration for BL motors

4.2.2 BL motors with analog hall sensors

The configuration for BL motors with analog hall sensors enables 4-quadrant operation. The sensors' position information is used both for commutation of the motor and for determining the speed.

Default basic parameters in this configuration:

- Due to the resolution of the analog hall sensors, speeds from approx. 50 rpm can be stably controlled.
- PWM frequency at the power output stage: approx. 96 kHz.
- 4 quadrant operation, therefore active acceleration and braking are possible.
- Maximum possible speed: 60 000 rpm
- If using the SC5004/SC5008 control, the fastest possible braking is carried out, taking into account the allowed motor current.

Block diagram:

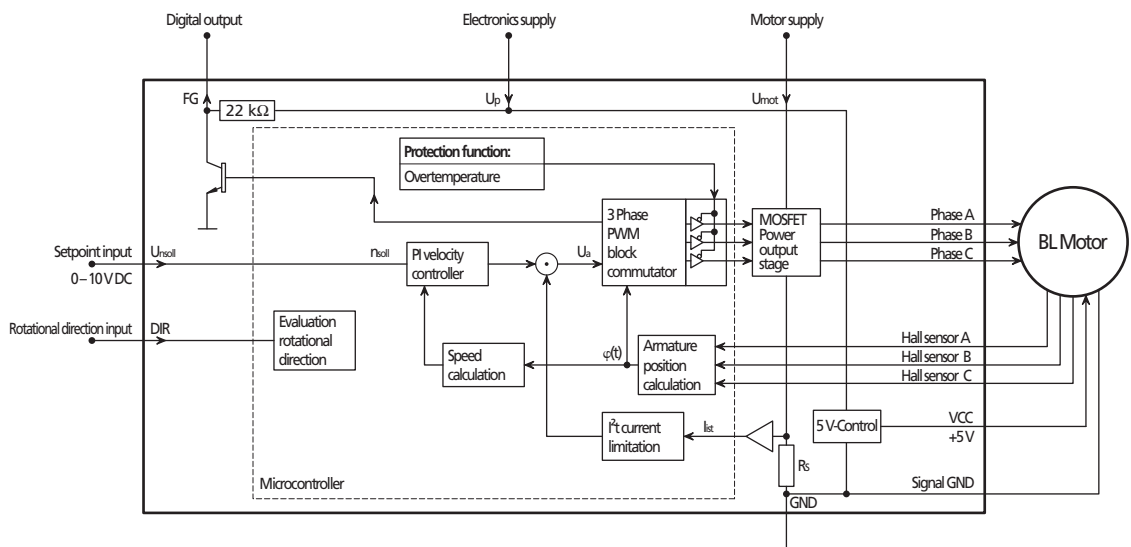

Setting options

- Filtering (averaging) of the hall sensor signals.
If problems occur with the default setting the time of a complete motor revolution is evaluated to obtain a continuous speed signal. This can cause instable motor running at low speeds as the control dynamics worsen.
- Frequency output can be configured to 1, 2, 3, 4, 8 or 16 pulses per revolution.
- Configuration of the digital output as error output.
- Speed setpoint input via PWM signal at the speed setpoint input See [Chapter 4.3 "Special Configurations"](#).
- Operation with fixed speed (fixed speed mode). See [Chapter 4.3.2 "Operation with fixed speed \(fixed speed mode\)"](#).
- Operation as voltage controller (volt mode). See [Chapter 4.3.3 "Operation as voltage controller \(volt mode\)"](#).

4 Configuration

4.2 Configuration for BL motors

4.2.3 BL motors without hall sensors (sensorless operation) (not SC5004 / SC5008)

In the configuration for BL motors without hall sensors, no hall sensors are used for the commutation even if they are available. The commutation signal is generated via the counter-EMF (back-induced voltage). The actual speed value is determined in sensorless operation via the time interval between the commutation switching points. 3 connections only are therefore required to operate the motor in this configuration.

The digital output is permanently programmed as a frequency output for sensorless operation with BL motors. The output signal can be set to 1, 3 or 6 pulses per revolution.

Default basic parameters in this configuration:

- The motor is started by means of a special algorithm, as no EMF is available while it is stopped and the position of the rotor is unknown. This can cause the motor to briefly (less than half a revolution) rotate in the wrong direction on starting. The starting time is longer compared to operation with hall sensors.
- At low speeds and under low load the speed is input by a rotating field. In this case an increase in load causes, among other things, a change in speed. Transition from rotating field operation to speed-controlled operation occurs.
- 2-quadrant operation. In rotating field operation the speed change occurs very soon after the change in the speed setpoint.
- Depending on the motor, speeds from approx. 1 000 rpm can be stably and constantly controlled.
- PWM frequency at the power output stage: approx. 24 kHz.

Motors up to a certain size, which do not work faultlessly due to too low inductance, can be operated in high-speed mode. See block diagram.

Block diagram:

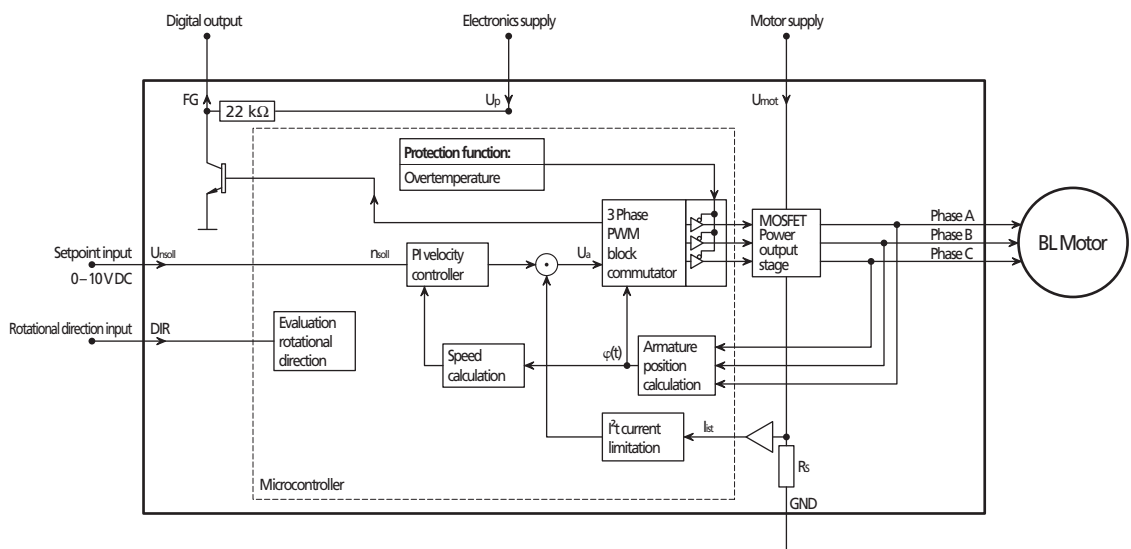

4 Configuration

4.2 Configuration for BL motors

Setting options

- High-speed mode for very small BL motors:

Designed for small motors with low inductance, small electric time constant and without hall sensors.

The speed is set with a low load and low speed values by inputting a rotating field. In this case the transition between rotating field mode and speed-controlled operation takes place by changing the speed setpoint input or by changing the load. To ensure constant speeds even if the load changes the operating range should lie outside this transition range. A suitable operating point can usually be found by reducing the motor supply voltage.

- Speed setpoint input via PWM signal at the speed setpoint input See [Chapter 4.3 "Special Configurations"](#).
- Operation with fixed speed (fixed speed mode). See [Chapter 4.3.2 "Operation with fixed speed \(fixed speed mode\)"](#).
- Operation as voltage controller (volt mode). See [Chapter 4.3.3 "Operation as voltage controller \(volt mode\)"](#).

4 Configuration

4.2 Configuration for BL motors

4.2.4 BL Motors with absolute encoder (AES-64 / AES-4096)

The configuration for BL motors with absolute encoders enables 4-quadrant operation. The detector's position information is used both for commutation of the motor and for determining the speed.

Default basic parameters in this configuration:

- Speed from 20 rpm (AES-4096) can be stably and constantly controlled due to the resolution of the detectors.
- 4 quadrant operation, therefore active acceleration and braking are possible.
- Maximum possible speed: 50 000 rpm (AES-4096).
- PWM frequency at the power output stage: approx. 96 kHz.
- Frequency output can be configured to 1, 2, 3, 4, 8 or 16 pulses per revolution.

NOTE



Number of pulses

At high speeds, more than 3 pulses per revolution can cause errors in the signal at the frequency output.

Block diagram:

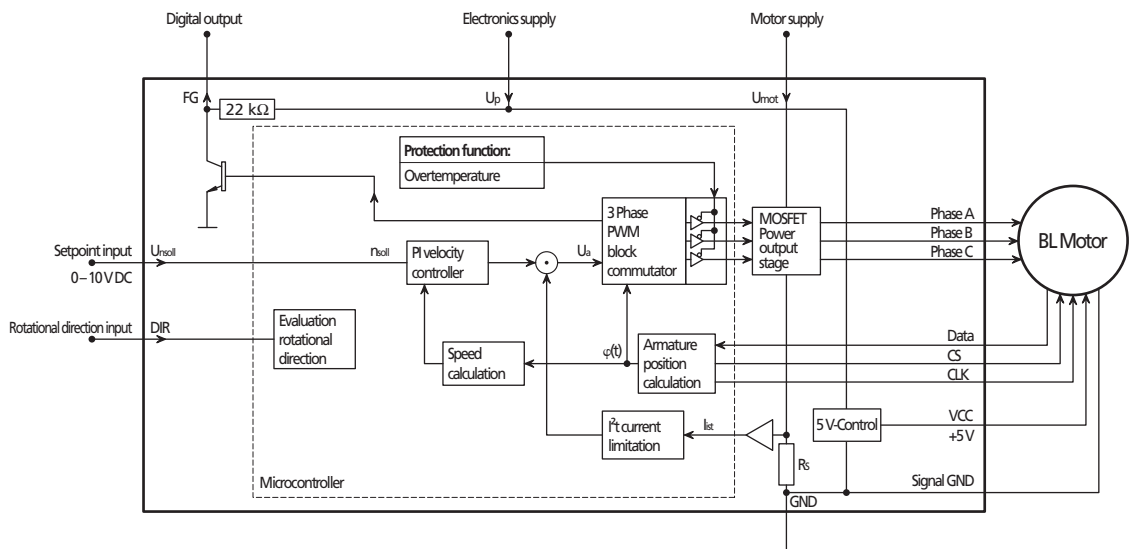

Setting options

- Speed setpoint input via PWM signal at the speed setpoint input See [Chapter 4.3 "Special Configurations"](#).
- Configuration of the digital output as error output.
- Operation with fixed speed (fixed speed mode). See [Chapter 4.3.2 "Operation with fixed speed \(fixed speed mode\)"](#).
- Operation as voltage controller (volt mode). See [Chapter 4.3.3 "Operation as voltage controller \(volt mode\)"](#).

4 Configuration

4.2 Configuration for BL motors

4.2.5 BL motors with digital Hall sensors and incremental encoder IE2

The configuration for BL motors with digital Hall sensors and incremental encoder enables 4-quadrant operation. The Hall sensors' position information is used for commutation of the motor, the encoder information is used for determining the speed.

Default basic parameters in this configuration:

- Due to the resolution of the encoder, speeds from approx. 50 rpm can be stably controlled.
- PWM frequency at the power output stage: approx. 96 kHz.
- 4 quadrant operation, therefore active acceleration and braking are possible.
- Maximum possible speed: 100 000 rpm.
- Frequency output can be configured to 1, 2, 3, 4, 8 or 16 pulses per revolution.
- If using the SC5004 / SC5008 control, the fastest possible braking is carried out, taking into account the allowed motor current.

Block diagram:

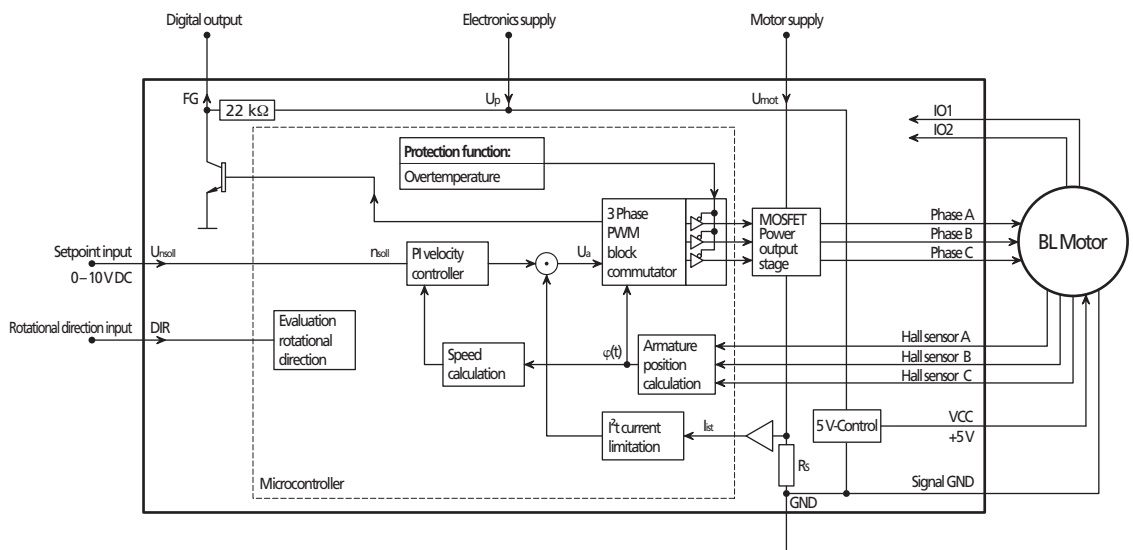

Setting options

- Filtering (averaging) of the speed signal. If problems occur with the default setting the speed information of the incremental encoder is filtered.
- Configuration of the digital output as error output.
- Frequency output can be configured to 1, 2, 3, 4, 8 or 16 pulses per revolution.
- Speed setpoint input via PWM signal at the speed setpoint input See [Chapter 4.3 "Special Configurations"](#).
- Operation with fixed speed (fixed speed mode). See [Chapter 4.3.2 "Operation with fixed speed \(fixed speed mode\)"](#).
- Operation as voltage controller (volt mode). See [Chapter 4.3.3 "Operation as voltage controller \(volt mode\)"](#).

4 Configuration

4.3 Special Configurations

In addition to the configurations described in [Chapter 4.1](#) and [4.2](#), further setting options exist which are equally possible for all motor types and all sensor variants. These configurations are described in this chapter.

4.3.1 Speed setpoint input via PWM signal

The speed setpoint input can take place via a PWM signal if the speed setpoint input U_{set} is appropriately configured. The speed setpoint is proportional to the pulse duty factor.

Basic parameter for the pulse duty factor

- PWM frequency range: 500 Hz – 18 kHz.
- Motor stops at pulse duty factor < 2.0 %.
- Motor runs at pulse duty factor > 3.0 %.
- The setpoint speed is proportional to the pulse duty factor. The maximum setpoint speed at 100 % can be configured. See [Chapter 4.4.5 "Maximum speed value"](#).

Block diagram:

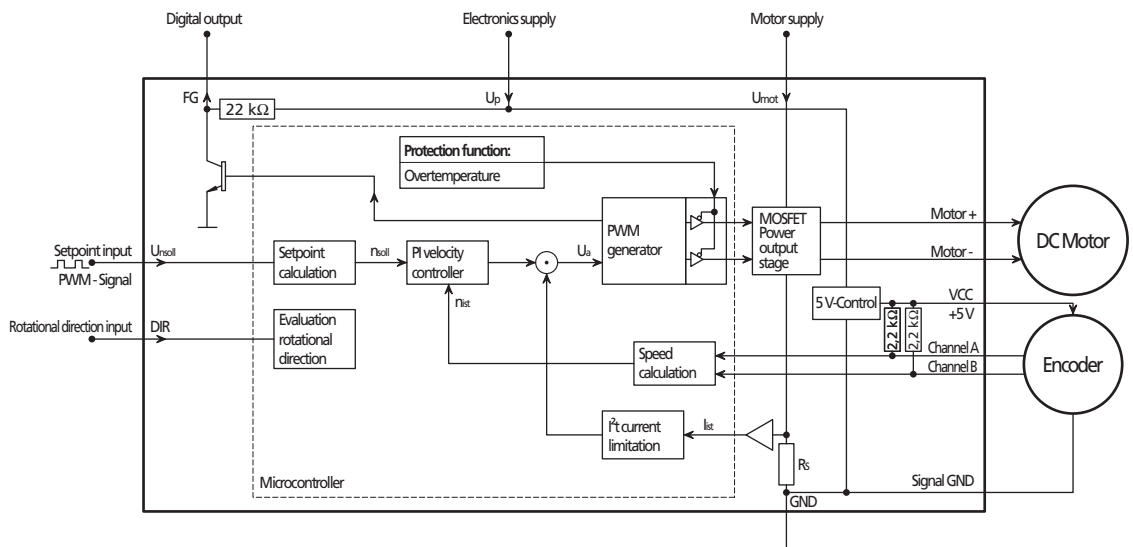

Setting options

- The TTL and PLC levels can be configured as switching levels:

Mode	high level	low level
TTL*	> 3.0 V DC	< 0.5 V DC
PLC	> 7.5 V DC	< 2.0 V DC

*not for SC5004/SC5008

4 Configuration

4.3 Special Configurations

4.3.2 Operation with fixed speed (fixed speed mode)

Fixed speed mode is possible for applications in which the motor is to be operated with a specific speed only. The setpoint speed to be set is fixed via a parameter (see [Chapter 4.4.3 "Fixed speed value"](#)).

Setting options for speed setpoint input U_{nsoll}

- Quick stop input (low level)
 - Motor stops at $U_{\text{nsoll}} < 0.15 \text{ V}$.
 - Motor stops if connection is open.
 - Motor runs at $U_{\text{nsoll}} > 0.3 \text{ V}$ (0.5 V for BL motors in sensorless operation).
- Quick stop input inverted (high level)
 - Motor runs at $U_{\text{nsoll}} < 2.0 \text{ V}$.
 - Motor runs if connection is open.
 - Motor stops at $U_{\text{nsoll}} > 2.4 \text{ V}$.
- No function
 - The motor always runs.

4.3.3 Operation as voltage controller (volt mode)

The speed controllers can be configured for function as voltage controllers. The motor voltage is then output proportionally to the voltage at the speed setpoint input U_{nsoll} . Current limiting remains active.

With this configuration it is possible to use a master controller. The speed controller is then used as a power amplifier only. In BL motors it is also used for commutation.

4.3.4 Digital output (FG)

The digital output is a switch which switches to GND (open collector with integrated pull-up resistance of 22 k Ω). It can be configured for different tasks:

- Error output
- Frequency output

The detailed properties of the configurations are described in [Chapter 3.4 "Connection functions"](#).

4 Configuration

4.4 Parameter settings

The following parameters can be used to adjust the speed controllers to the respective application. Several parameters have a function in certain configurations only or with specific settings only.

4.4.1 Motor constants

In sensorless operation of DC motors the actual speed value is determined via an internal motor model. The motor constants must be configured for the following uses to enable smooth operation:

- DC motor in sensorless operation
- Speed-controlled operation with SC5004/SC5008

Parameter	Meaning	Value range	Units
Generator voltage constant (k_E)	Gives the voltage generated by the motor in generator operation depending on the speed.	0 – 327	mV/rpm
Connection resistance (RM)	Connection resistance of the connected motor.	0 – 327	Ω

4.4.2 Current limiting values

For the I²t current limiting, the peak current (I_{max}) and the motor continuous current (I_{cont}) must be input. See also [Chapter 4.5.1 “I²t current limiting”](#). The allowable values of the speed controller used as well as of the connected motor must be noted and observed.

Parameter	Meaning	max. value SC1801	max. value SC2804	max. value SC5008	Units
Motor continuous current (I_{cont})	Value for the continuous current which is the limit value.	1	5	10	A
Peak current (I_{max})	Value for the maximum current allowed for a short time (transient maximum current).	2	10	20	A

4.4.3 Fixed speed value

For operation with a fixed speed the speed setpoint is input via an adjustable parameter. See [Chapter 4.3.2 “Operation with fixed speed \(fixed speed mode\)”](#).

Parameter	Meaning	max. value	Units
Fixed speed value (NsetFix)	Speed setpoint, which is input in operation with fixed speed.	Depends on the motor type and operating mode	rpm

Operating mode / motor type	max. value	Units
BL motors with digital hall sensors	120 000*	rpm
BL motors with analog hall sensors	60 000*	rpm
BL motors with absolute encoder AES-4096	50 000	rpm
BL motors in sensorless operation	25 000*	rpm
BL motors in high-speed sensorless operation	65 000*	rpm
BL motors with incremental encoder	30 000	rpm
DC motors with incremental encoder or in sensorless operation	65 000	rpm

* Values apply to 2-pole motors

4 Configuration

4.4 Parameter settings

4.4.4 Pulses per motor revolution

With BL motors it is possible to configure the digital output FG as a frequency output (this is the default configuration). The number of pulses per motor revolution can be set depending on the detector used.

Parameter	Meaning	Possible values	Units
Pulses per revolution	Number of pulses per revolution at the digital output.	Depends on the detector type.	1/rev
Detector type		Possible values	Units
Digital hall sensor		1, 3	1/rev
Analog hall sensor		1, 2, 3, 4*, 8*, 16*	1/rev
Sensorless operation		1, 3, 6	1/rev
AES-4096		1, 2, 3, 4*, 8*, 16*	1/rev
Incremental encoder		1, 2, 3, 4*, 8*, 16*	1/rev
Values apply to 2-pole motors. The given values double for 4-pole motors (not for AES).			
*At high speeds, more than 3 pulses per revolution can cause errors in the signal at the frequency output.			

4.4.5 Maximum speed value

When inputting the speed setpoint (as an analog voltage or as a PWM signal) the speed value, which is input at 10 V DC or at 100% pulse duty factor, can be set. This enables the maximum speed value to be adjusted to the motor type or application.

Different resolutions of the maximum speed value and different maximum values are possible, depending on the operating mode and motor type.

NOTE



Speed information

The given speed values refer to the "electrical speed" of the motor. In BL motors with more than two poles the "mechanical speed" is correspondingly lower ($n_{mech} = 2 \cdot n_{el} / \text{number of poles}$).

Parameter	Meaning	Possible values	Units
Maximum speed value (NsetMax)	Maximum speed setpoint at 10 V or 100 % pulse duty factor at the speed setpoint input U_{nsoll} .	Depends on the motor type and operating mode	rpm
Operating mode / motor type		max. value	Increment
BL motors with digital hall sensors		120 000*	10
BL motors with analog hall sensors		60 000*	10
BL motors with absolute encoder AES-4096		50 000*	10
BL motors in sensorless operation		25 000*	2 500
BL motors in high-speed sensorless operation		65 000*	5 000
BL motors with incremental encoder		30 000	10
DC motors with incremental encoder or in sensorless operation		65 000	10
* Values apply to 2-pole motors			

4 Configuration

4.4 Parameter settings

4.4.6 Controller parameter

The speed controller is set in the factory so that problem free operation is usually possible. The speed controllers have an integrated feature for specifying appropriate parameters if adjustment of the controller to the controlled system is necessary for special applications. See [Chapter 4.5.3 "Adjusting the controller parameters"](#).

The targets set for the control's properties also depend on the application.

Above all, a differentiation is made between the stiffness of the control, the uniformity of the speed within a revolution, the allowed system deviation, the allowed overswing and the required stability reserves.

The control circuit must also satisfy these requirements so that the controller parameters must also be adjusted with respect to these.

The PI speed controller used here enables two parameters to be set (proportional and integral-action component).

Parameter	Meaning	max. value	Units
V	Proportional component	32767	Digit
VI	Proportional component multiplied by the integral-action component	65535	Digit

NOTE



Parameter dependencies

The I term of the controller reduces if V is increased while VI remains unchanged!

If the I term is to remain unchanged, VI must be multiplied by the same factor as V!

4.4.7 encoder resolution

The resolution of the connected encoder in DC motors with encoder must be input as otherwise the drive would control at the wrong speed values.

The parameter gives the resolution so that 4-edge evaluation would count correspondingly far per revolution. The parameter is therefore pulse rate from the encoder's data sheet multiplied by 4.

Parameter	Meaning	max. value	Units
encoder resolution (Encres)	4-fold pulse rate of the encoder per revolution	65535	Digit

4.4.8 Starting time (for BL motors in sensorless operation only)

In sensorless operation of BL motors the acceleration is realised via synchronous operation. The time between the switchover from one commutation state (phase) to the next can be set to the connected motor.

Parameter	Meaning	max. value	Units
Starting time (StartTime)	Switchover time between the phases in acceleration	2 739	ms

4 Configuration

4.4 Parameter settings

4.4.9 Minimum speed (for BL motors in sensorless operation only)

As the speed must reach a certain value for BL motors in sensorless operation to ensure stable operation, a minimum setpoint speed value is useful. Even if a lower speed would result due to other parameters or the speed setpoint input, nevertheless at least the speed set in this parameter is input.

Parameter	Meaning	max. value	Units
Minimum speed (NsetMin)	Minimum speed setpoint input	25 000	rpm

4.4.10 Delayed Current Error (with error output only)

Activation of the output can be delayed. Even if the current is already limited the output is not activated until after the time input with DCE. As a result, short-term exceeding of the limit current can be ignored.

Parameter	Meaning	max. value	Units
Delayed Current Error (DCE)	Delay of activation of the error output	5 100	ms

4 Configuration

4.5 Technical information

4.5.1 I²t current limiting

The speed controllers are equipped with current limiting which enables certain motor protection to be achieved.

How the current limiting works:

When the motor is started the peak current is input as the setpoint at the current regulator. As the load increases the current in the motor increases until it finally reaches the peak current. From then the current regulator comes into action and limits the current to the current setpoint.

Parallel with this a thermal current model runs which calculates a model temperature from the currently flowing current. If this model temperature exceeds a critical value the motor switches to continuous current and the motor current is controlled with this value. Peak current is not allowed again until the load is so low that the temperature falls below the critical model temperature.

The aim of this so-called I²t current limiting is not to heat the motor above the thermally allowable temperature by selecting a suitable continuous current. On the other hand, short-term high load should be possible to enable very dynamic movements to be realised.

Peak current (I_{max})

The current is limited to the peak current as long as the thermal current model calculates a non-critical temperature.

Continuous current (I_{cont})

If the thermal current model reaches a critical temperature the motor is switched to continuous current.

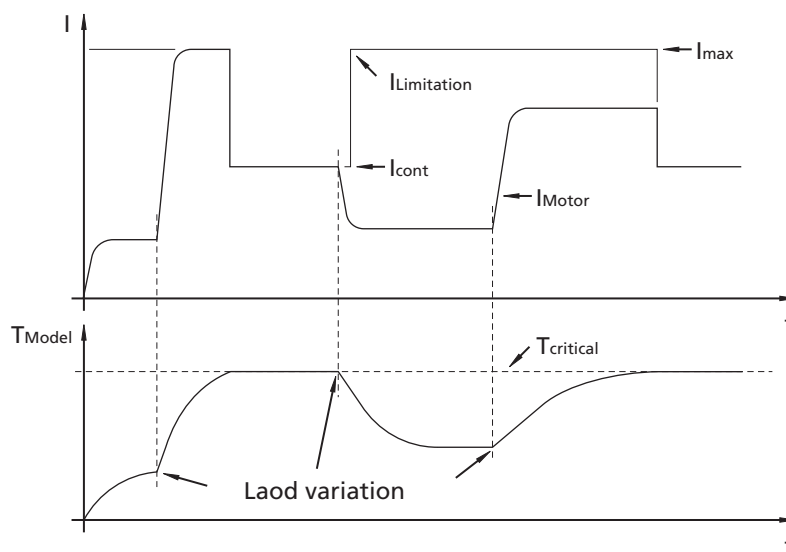

4 Configuration

4.5 Technical information

4.5.2 Overtemperature cut-off

The motor is deactivated if the temperature of the electronics exceeds a certain limit value.

The following condition must be fulfilled to reactivate the motor:

- Temperature below a set limit value

4.5.3 Adjusting the controller parameters

The controller parameters are already set to default values for common applications. However, the controller parameters can be optimised to optimally adjust the controller to the respective application.

The digital controller operates with a sampling rate of approx. 500 μ s.

Example of controller setting:

1. Set the initial configuration.
2. Increase controller gain (proportional component V).
3. Input speed jump from 1/3 of the maximum speed to 2/3.
4. Speed jump from 2/3 to 1/3 and observe behaviour.
5. Repeat step 2 to 4, until the controller becomes unstable. Then reduce the controller gain until it is reliably stable.
6. Repeat steps 2 to 5 with proportional integral-action component (VI).

4.5.4 Effect of pulse width modulation (PWM)

The power output stage of the speed controllers operates with so-called pulse width modulation (PWM). At a fixed frequency (the PWM frequency) the pulse duty factor is set between the on time and the off time depending on the controller output value.

The advantage of this procedure is that the losses in the drive electronics are very low. In contrast, the losses in a linear output stage can be very large and it becomes hot.

When the PWM is used the motor's inductance is used as a filter for the current. Therefore, the PWM frequency should be high enough to adequately filter the current. If the PWM frequency is too low for a specific motor the motor operators with a worse efficiency than it would in direct voltage operation.

NOTE



Efficiency

Please note that a reduction in efficiency at the motor also reduces the maximum allowable current and therefore the maximum continuous torque.

Example

- Motor: 2232U012SR
- Connection resistance $R = 4.09 \Omega$
- Connection inductance $L = 180 \mu\text{H}$
- Operating point $n = 4\,000 \text{ rpm}$
- Motor supply voltage $U_{\text{mot}} = 18 \text{ V DC}$
- PWM pulse duty factor $d = 50 \%$ (corresponds to a direct voltage of 9 V DC at the motor.)
- Efficiency for operation with real direct voltage $\eta_{\text{gl}} = 74.7 \%$.

4 Configuration

4.5 Technical information

Case 1: PWM frequency = 24 kHz

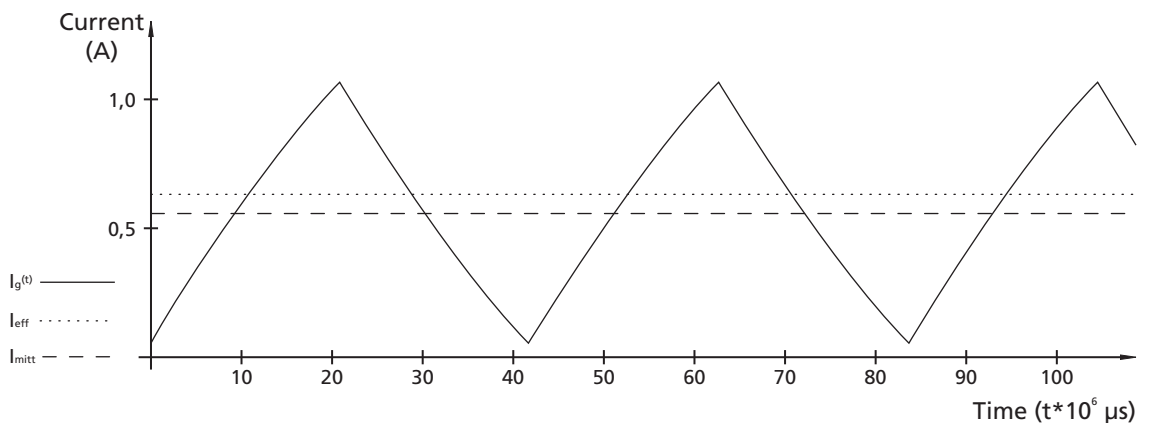

- Efficiency for operation with PWM $\eta_{\text{PWM}} = 69,6 \%$.

Case 2: PWM frequency = 96 kHz

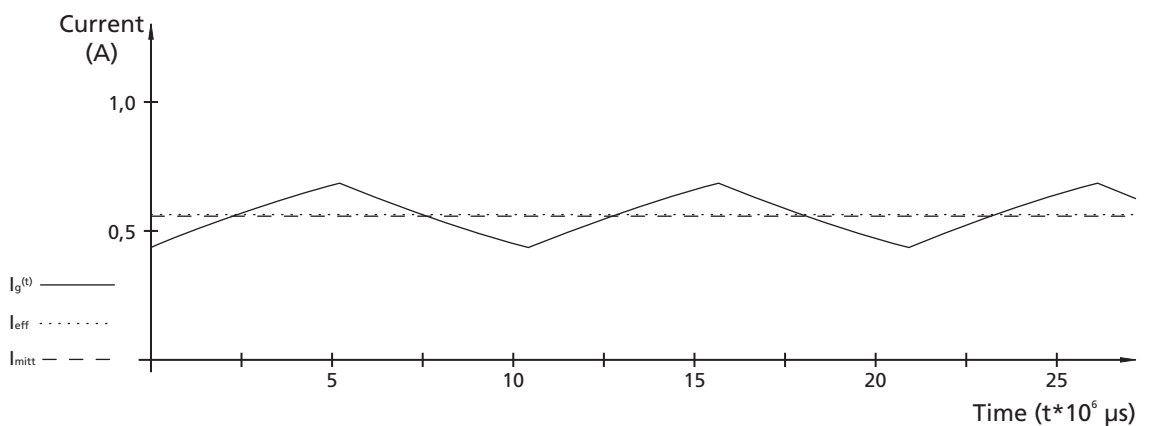

- Efficiency for operation with PWM $\eta_{\text{PWM}} = 74,3 \%$.

Result:

A better motor efficiency can be achieved at a higher PWM frequency and the current has a lower ripple.

Alternatively, additional inductance in series with the motor can improve the motor efficiency.

In this example, at 96 kHz there is hardly any difference between direct voltage and PWM operation so that an additional inductance can be dispensed with here.

The efficiency of the motor is also improved if the speed controller is operated at full or almost full drive.

NOTE



PWM pulse duty factor

A low PWM pulse duty factor can cause a lower efficiency in the speed controller and the motor connected to it.

5 Operation

5.1 Startup

CAUTION!



Risk of damage!

Connecting live cables can damage the electronics:

- ▶ *Do not carry out any connection work on the Speed Controller unless the power supply has been switched off.*

Incorrect connection can cause damage or complete destruction of the Speed Controller.

- ▶ *Before switching on the power supply, ensure that all connections are correct*

Before starting up the speed controller together with a motor the following points must be checked:

- The speed controller has been installed according to the requirements.
- The connection cables on the supply and motor end are connected according to the requirements (risk of polarity reversal!) and are laid so that they cannot be damaged during operation. The maximum load values must be noted and observed.
- The length of the motor connection cable is not longer than 30 cm.
- Terminals and connectors are protected against ESD.
- The speed controller's parameters are suitably configured for the connected motor.
- The motor operating point has been selected so that at maximum load the greatest possible PWM pulse duty factor sets in at the controller output. If necessary, reduce the motor supply voltage U_{mot} .
- The power supply unit is designed according to the requirements.

CAUTION!



Power supply

Due to the PWM of the power output stage the motor current is always larger or equal to the current that can be measured at the supply connection U_{mot} . The current information (continuous/peak output current) in the data sheets and the adjustable parameters of the I^2t current limiting refer to the motor current and not to the supply current of the speed controller!

6 EC Product Safety Directives

REGULATION! The following EC Product Safety Directives are important for users of the described products:



Machinery Directive (2006/42/EC):

Due to their small size, small standard electrical drives cannot cause any noteworthy risk of injuries to people.

Therefore, the Machinery Directive does not apply to our products.

The products described here are not “part machines” or “incomplete machines”.

Therefore, Faulhaber does not provide a standard Declaration of Incorporation.

Low-Voltage Directive (2006/95/EC):

It applies to all electrical equipment with a nominal voltage from 75 to 1 500 V DC, or from 50 to 1 000 V AC. The products described in this instruction manual do not fall within the scope of this Directive as they are designed for smaller voltages.

EMC Directive (2004/108/EC):

The Electromagnetic Compatibility (EMC) Directive applies to all electronic and electrical equipment, plant and systems sold to end users (consumers). In addition, CE marking can be undertaken for built-in components according to the EMC Directive. Compliance is documented by the Declaration of Conformity.

7 Warranty

Extract from our warranty conditions

Dr. Fritz Faulhaber GmbH & Co. KG products are produced to state of the art production methods and are subject to strict quality control.

Should, contrary to all expectations, defects occur, we undertake to find a remedy within the warranty period.

- We shall make good or replace defective goods, at our own discretion, within a reasonable period set by you and at our own cost. Replaced goods become our property and are to be returned to us.
- If improvement or replacement delivery is not possible or does not occur or fails for other reasons for which we are responsible within a period determined by you, you can opt to withdraw from the contract for the defective delivery or reduce the purchase price.
- We are not liable for damage to the goods caused by natural wear and tear, wear, unsuitable, improper or non-contractual use, incorrect assembly, installation or putting into service, excessive loading or improper change, improvement or repair work by you or third parties or incorrect or negligent treatment, provided these are not through our fault.
- Further claims, in particular claims for compensation instead of the performance and for compensation of other direct or indirect losses – including accompanying or consequential loss, for whatever legal reason – are excluded. This does not apply if
 - a) we are maliciously silent with regard to a legal or material defect or have issued a guarantee for the nature of the goods,
 - b) the loss is due to deliberate intent or gross negligence by us, our legal representatives or vicarious agents or are based on negligent breach of fundamental contract obligations by these persons, or
 - c) culpable violation of duty by us, our legal representatives or vicarious agents which have resulted in physical injuries or damage to health.

In the case of simple negligence, however, our obligation to pay damages is limited to the amount of typical, foreseeable losses for the type of contract.

- All defect claims including the claims for compensation covered by our terms and conditions of supply expire one year after delivery of the goods to you. The limitation period for replacements and improvements is 1 year but it expires at least when the original limitation period for the delivered object expires. The period for defects liability for a supplied object will be extended by the duration of the operational interruption caused by the making good work. Provisions concerning a shorter life of the object supplied within the scope of its intended use remain unaffected by this limitation provision.

For further information, please refer to our terms and conditions of supply, which we will be pleased to make available on request.

8 Index

Absolute encoder

Position information is detected immediately after switching on (within a motor revolution).

Incremental encoder

encoder which generates pulses when the position changes. These can be summed using an external counter.

ESD (Electrostatic Discharge)

Electrostatic discharge.

DC motor

Motor which is operated with direct current.

BL motor

Brushless direct current motor. The commutation takes place with the help of an electronic circuit (e.g. FAULHABER Speed Controller).

LIF

Connector system which can be joined with small effort.

ZIF

Zero Insertion Force.

FFC (Flat Flex Cable)

Flat flex cable

FPC (Flexible Printed Circuit)

Flexible printed circuit board, e.g. made of polyamide film with printed on conductors.

PLC mode

Switching levels (24V) from the automation engineering are used.

TTL mode

Logical switching levels (5V) from the electronics are used.

Pull-up resistance

Resistance which defines the level of an open or high-resistance input/output. Level is pulled up (high).

Ripple

Alternating component of a current or of a voltage.

PWM

Pulse width modulation.

