

# Plug Connector for AdvancedMC™ modules

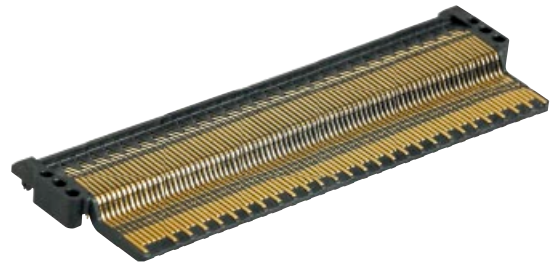

For mounting on extended side

Identification	No. of contacts	Part number
AdvancedMC™ Plug Connector for extended side mounting replacement of former part number 16 21 170 1301 000	170	16 21 170 1303 000
AdvancedMC™ Plug Connector for extended side mounting with nozzle pad for pick and place assembly replacement of former part number 16 21 170 1302 000	170	16 21 170 1304 000

## AdvancedMC™ Plug Connector for extended side mounting

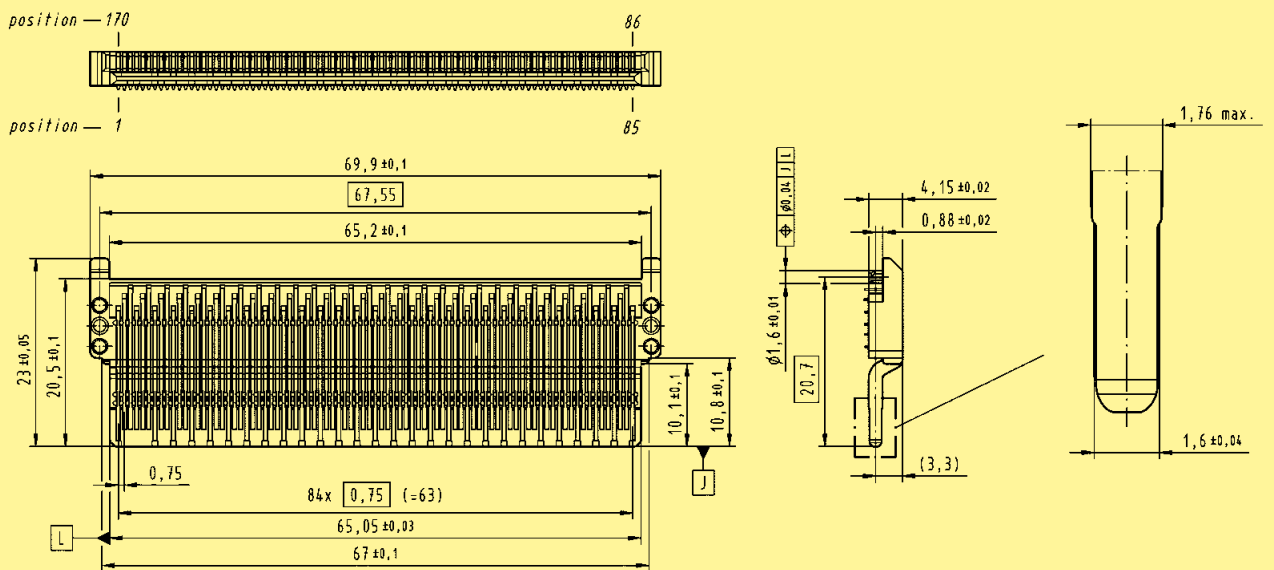

## Board drillings (view of the extended side / component side 2)

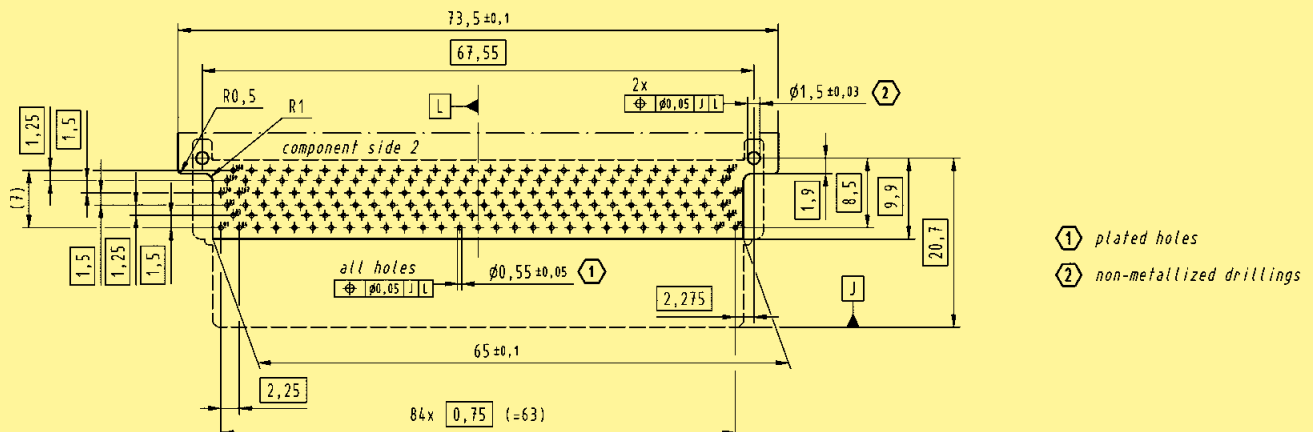

Dimensions [mm]