

Cannon Speedy D

IDC contacts

Speedy D connectors terminate ribbon cables without stripping and without splicing. They are intermateable with all D Subminiature types offered on the market. The extremely low profile is another typical feature of the Speedy D.



Technical Data

Materials

| | |
|------------------|--|
| Shell | Steel, with pure tin matt |
| Insulator | High quality thermoplast, flame retardant, UL94V-0 |
| Contacts | Copper alloy |
| Contact area | gold-plated over nickel |
| Termination area | pure tin, matt |

Mechanical Features

| | |
|---|--|
| Coupling | Friction, accessories |
| Polarizing | Keystone shape shell |
| Termination | IDC |
| Wire sizes | AWG 26 (0,13mm ²), AWG 28 (0,08mm ²) solid or stranded |
| Ribbon cable | Conductor spacing 1,27mm |
| Temperature rating to DIN IEC 68 part 1 | -55/125°C |

Electrical Data

| | |
|-----------------------|--|
| Current rating | 1.5 A at 25°C, 1 A at 70°C ambient temperature |
| Contact resistance | 15 mOhm (milli Ohm) |
| Voltage rating | 780 VAC |
| Insulation resistance | 5 x 10 ³ MOhm (Mega Ohm) |
| Air/creepage paths | minimum 0,9mm |

Standard Contact Arrangements

Contact size 20
Face view pin insert

Shell size
No. of contacts

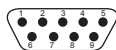

E
9

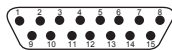

A
15

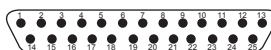

B
25

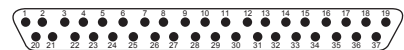

C
37



Dimensions shown in mm
Specifications and dimensions subject to change.

www.ittcannon.com

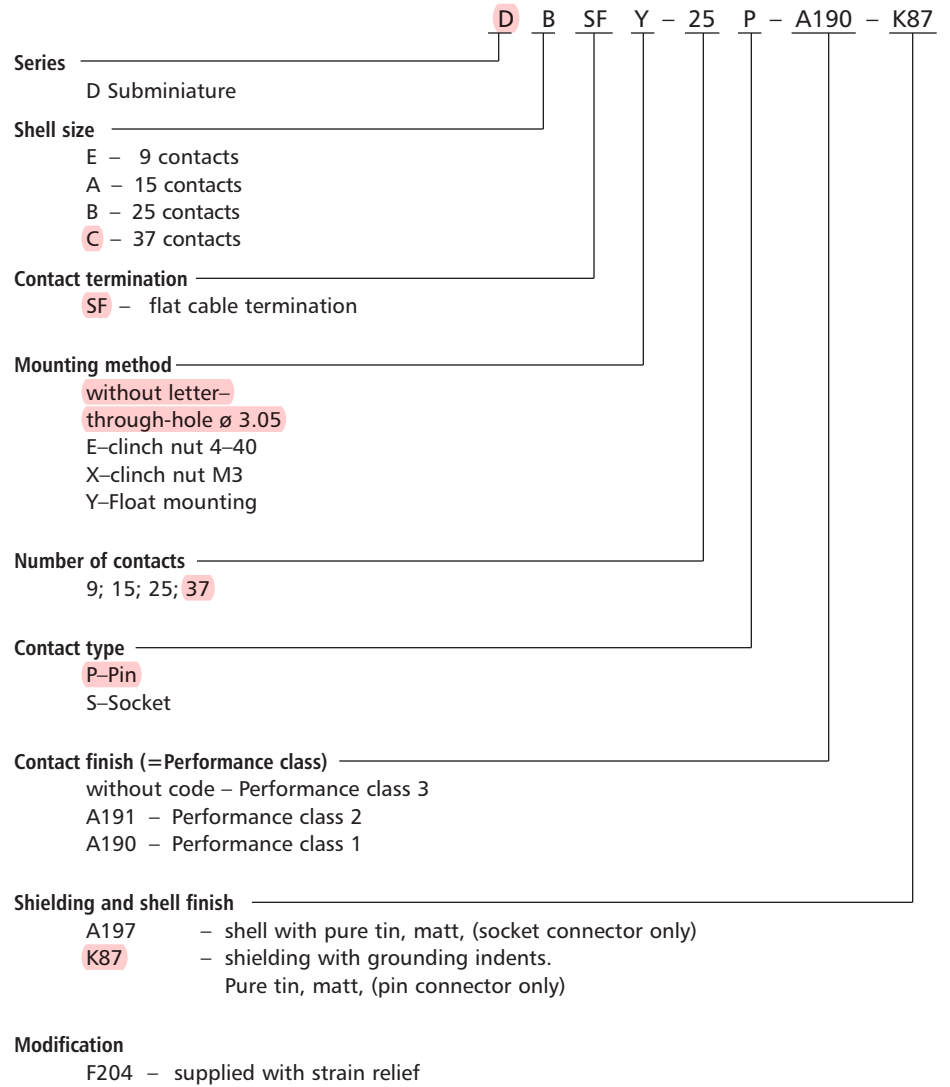

Contact finishes/Performance class

- without code – performance class 3 (50 mating cycles) is standard version of Speedy D
- A191 – performance class 2 (200 mating cycles)
- A190 – performance class 1 (500 mating cycles)

Receptacle

| No. of contacts | Through-hole | Float mount | Clinch nut 4-40* |
|-----------------|----------------|-----------------|------------------|
| 9 | DESF- 9 S-A197 | DESFY- 9 S-A197 | DESFE- 9 S-A197 |
| 15 | DASF-15 S-A197 | DASFY-15 S-A197 | DASFE-15 S-A197 |
| 25 | DBSF-25 S-A197 | DBSFY-25 S-A197 | DBSFE-25 S-A197 |
| 37 | DCSF-37 S-1A97 | DCSFY-37 S-A197 | DCSFE-37 S-A197 |

or metric thread replace E by X

Plugs

(pin connector only)

| No. of contacts | with grounding indents | Float mount | Clinch nut 4-40* |
|-----------------|------------------------|---------------|------------------|
| 9 | DESF- 9P-K87 | DESFY- 9P-K87 | DESFE-9P-K87 |
| 15 | DASF-15P-K87 | DASFY-15P-K87 | DASFE-15P-K87 |
| 25 | DBSF-25P-K87 | DBSFY-25P-K87 | DBSFE-25P-K87 |
| 37 | DCSF-37P-K87 | DCSFY-37P-K87 | DCSFE-37P-K87 |

or metric thread replace E by X

Performance class

Performance class 1: A190 into order ref.

Performance class 2: A191 into order ref.

e.g. DESF—9P-A190-K87 or

DESF—9S-A191-A197

Cable strain relief

| No. of contact | Order No. |
|----------------|--------------|
| 9 | 029-8757-009 |
| 15 | 029-8757-015 |
| 25 | 029-8758-025 |
| 37 | 029-8757-037 |

Mounting combinations

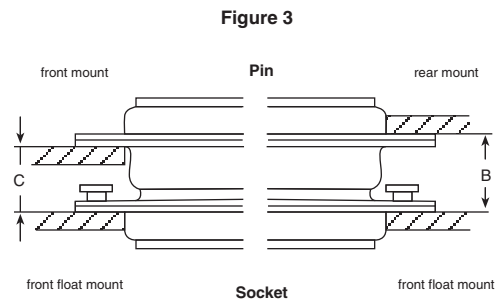
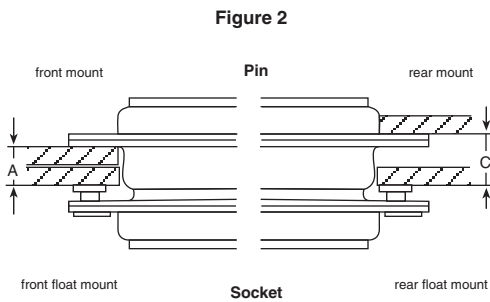
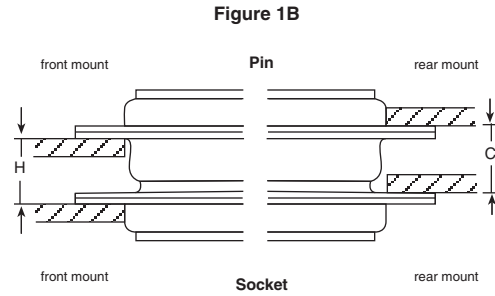
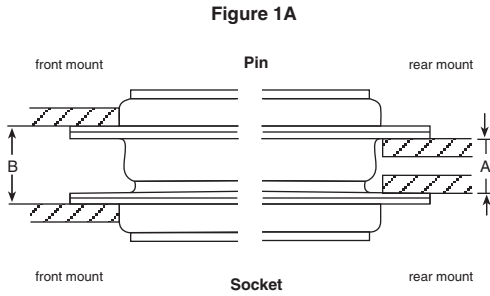

| Fig. | Size | Pin | Socket | A +0,76 | B +0,76 | C +0,76 | H _0,76/-0 |
|------|---------|----------|----------|------------|------------|------------|---------------|
| 1A | A, E | Standard | Standard | 6,35 | 7,63 | 6,99 | 6,99 |
| 1B | B, C, D | Standard | Standard | 6,04 | 7,71 | 7,06 | 6,68 |
| 2 | A, E | Standard | float | 5,53 | – | 6,18 | – |
| 2 | B, C, D | Standard | float | 5,23 | – | 6,25 | – |
| 2 | A, E | float | Standard | 5,53 | – | 6,18 | – |
| 2 | B, C, D | float | Standard | 5,23 | – | 5,87 | – |
| 3 | A, E | Standard | float | – | 8,59 | 7,95 | – |
| 3 | B, C, D | Standard | float | – | 8,66 | 7,64 | – |
| 3 | A, E | float | Standard | – | 8,59 | 7,95 | – |
| 3 | B, C, D | float | Standard | – | 8,51 | 7,87 | – |

Remark:

A, B, C and H are dimensions between panels and represent the recommended limit to be used in the design of the connector mounting method.

Standard pin assemblies contain 0,38 mm thick front shells on E and A sizes and 0,61 mm thick shells on B, C and D sizes.

Panel cut-outs

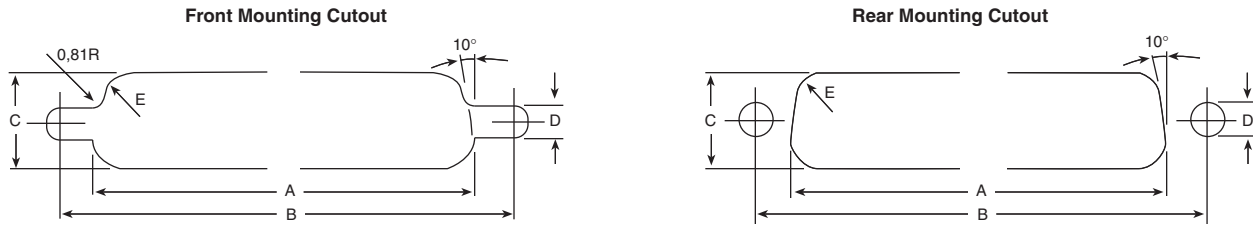

| no. of contacts | mounting | A | B | C | D | rad. E |
|-----------------|----------|------|------|------|------|--------|
| | | ±0,2 | ±0,2 | ±0,2 | +0,1 | ±0,2 |
| 9 | front | 22,2 | 25,0 | 13,0 | 3,0 | 2,1 |
| | rear | 20,5 | 25,0 | 11,4 | 3,0 | 3,4 |
| 15 | front | 30,5 | 33,3 | 13,0 | 3,0 | 3,4 |
| | rear | 28,8 | 33,3 | 11,4 | 3,0 | 3,4 |
| 25 | front | 44,3 | 47,0 | 13,0 | 3,0 | 2,1 |
| | rear | 42,5 | 47,0 | 11,4 | 3,0 | 3,4 |
| 37 | front | 60,7 | 63,5 | 13,0 | 3,0 | 2,1 |
| | rear | 59,1 | 63,5 | 11,4 | 3,0 | 3,4 |
| 50 | front | 58,3 | 61,1 | 15,8 | 3,0 | 2,1 |
| | rear | 56,3 | 61,1 | 14,9 | 3,0 | 3,4 |

| No. of contacts | float mounting | A | B | C | D | rad. E |
|-----------------|----------------|------|------|------|------|--------|
| | | ±0,2 | ±0,2 | ±0,2 | +0,1 | ±0,2 |
| 9 | front | 23,0 | 25,0 | 13,8 | 2,2 | 2,1 |
| | rear | 21,3 | 25,0 | 12,2 | 2,2 | 3,4 |
| 15 | front | 31,3 | 33,3 | 13,8 | 2,2 | 2,1 |
| | rear | 29,6 | 33,3 | 12,2 | 2,2 | 3,4 |
| 25 | front | 45,1 | 47,0 | 13,8 | 2,2 | 2,1 |
| | rear | 43,3 | 47,0 | 12,2 | 2,2 | 3,4 |
| 37 | front | 61,5 | 63,5 | 13,8 | 2,2 | 2,1 |
| | rear | 59,8 | 63,5 | 12,2 | 2,2 | 3,4 |
| 50 | front | 59,2 | 61,1 | 16,6 | 2,2 | 2,1 |
| | rear | 57,1 | 61,1 | 14,9 | 2,2 | 3,4 |

Mounting

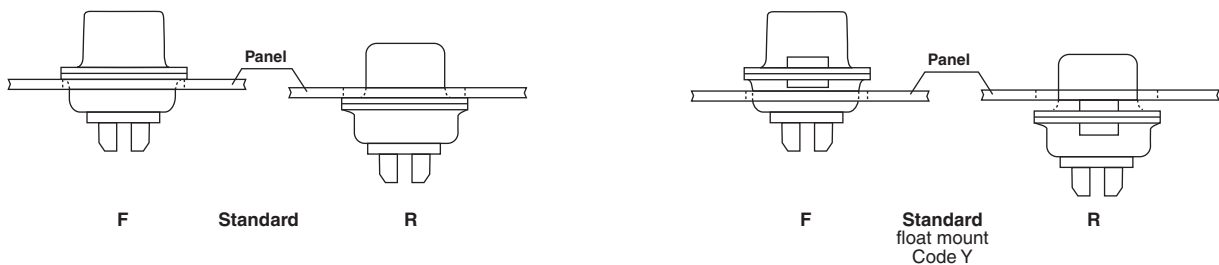

F – front mounting
R – rear mounting