

Datasheet

Art.No. 07.313.2955.0

End plate

End plate for DIN rail terminal block type WT 4 TKM and WT 4 D1/2, color gray



Art.No.	07.313.2955.0
EAN	4049088168086
Order unit	10 pieces

Approvals

Technical data

General

Colour	Grey
Type of end plate	Yes
Type of partition	No
Thickness	2 mm
Snap in	Yes
Inflammability class of insulation material acc. with UL94	V0

Accessories

Type of end plate	Yes
Type of partition	No
Colour	Grey
Thickness	2 mm
Snap in	Yes
Inflammability class of insulation material acc. with UL94	V0

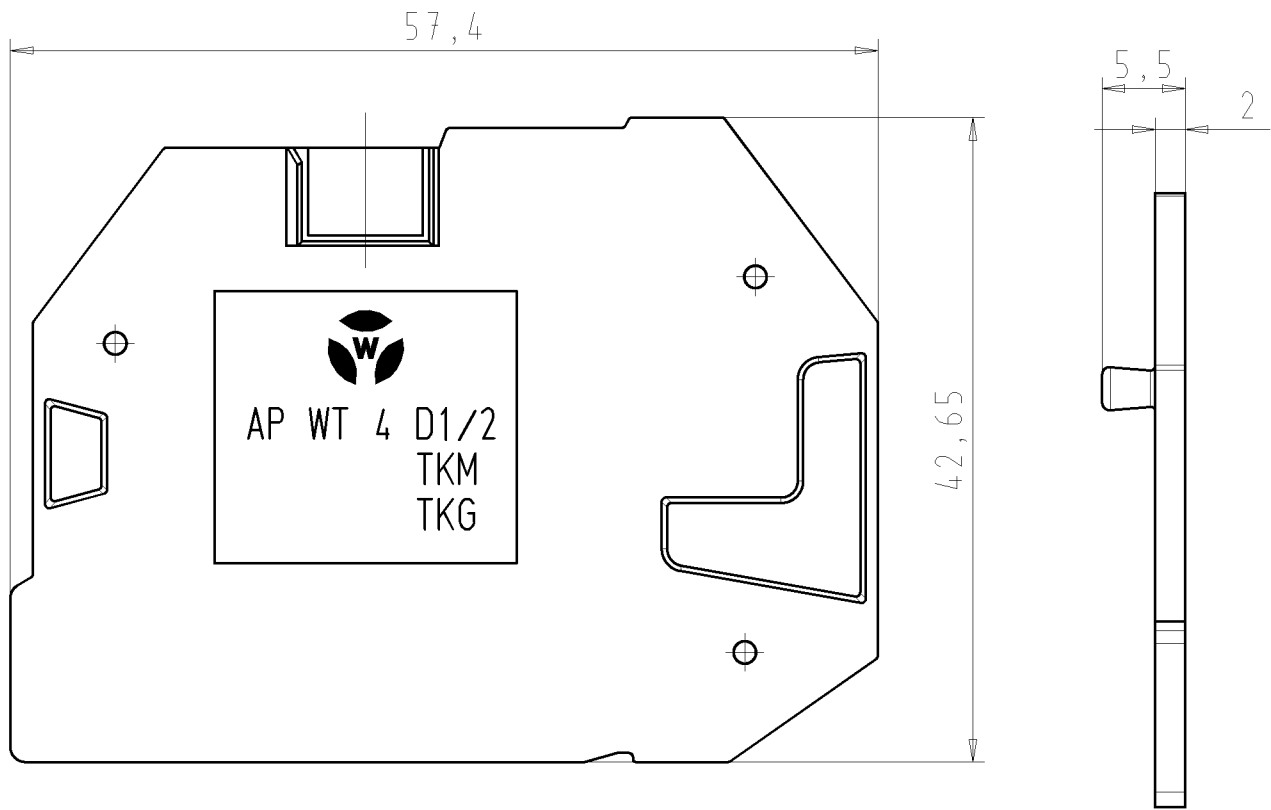

M/scale 1:1

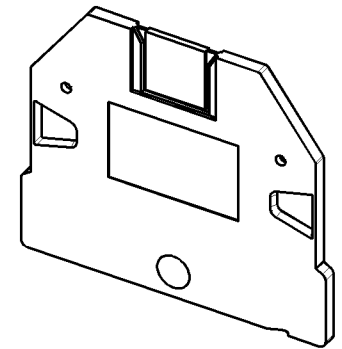

Weitere Daten siehe Katalog
further data see catalog

Teile-Nr. part-no.	Farbe color	Type type
07.313.2955.0	grau, ähnl. RAL 7032 grey, similar to RAL 7032	AP WT 4 D1/2-TKM-TKG GR
07.313.2955.1	schwarz, ähnl. RAL 9005 black, similar to RAL 9005	AP WT 4 D1/2-TKM-TKG SW

Tolerierung Size ISO 14405 (E) / Tolerance system Size ISO 14405 (E).
 [This ISO-standard describes the envelope principle. According to the envelope principle the deviations of form and parallelism are limited by the size tolerances].
 ja/yes Stoffverbots- und Deklarationsliste nach UU-TQM-05/03 ist einzuhalten.
 Conformity with Wieland document UU-TQM-05/03 (list of prohibited / declarable hazardous substances) to be declared!

Freitoleranz nach General tolerance CAD - Zeichnung, keine manuellen Änderungen CAD - drawing, no manual modifications allowed 1.Verwendung: - First Use: - Blatt: 1 von 1 Sheet: 1 of 1

Werkstoff/Material	2013	Tag/Date	Name	Zeichnung Nr./Drawing No.	Index
 Maßstab/Scale 2:1	gezeichnet drawn	16.01	Eller	T 07.313.2955.0 01K	
	geprüft checked	-	-		
	Normgepr. Stand., check	-	-		

Maße in mm/Dimensions are in mm

Vol. mm³ Oft./Surf. mm² Ersatz für/Replacement for: -

Type	Benennung/Title
 wieland Elektrische Verbindungen	ABSCHLUSSPLATTE end plate

Index Datum / Blatt Date / Sheet Änderung/Revision

These dimensions will be especially checked at delivery
Only inspection dimensions
With /E marked dimensions are only valid for internal use

Diese Maße werden bei Abnahme besonders geprüft
Ausschließlich Prüfmaße
Mit /E gekennzeichnete Maße sind nur für interne Zwecke gültig

1
2
3
4
5
6
7
8
9
10
11
12
13
14
15
16
17
18
19
20
M1
M2
M3
L
G
i
11.1
12.1
1.1
073132955001K_2 CADW3070 U0016728 2013-01-16T09:02:23 1.000