

**Ordering number** CS12862_STRADA-IP-2X6-DWC

Family	Strada-IP	FWHM	Asym degrees
Type	Lens array	Efficiency	96 %
LED	LUXEON Rebel ES	cd/lm	0.560
Color	Clear	Gerber File	Available
Diameter	173x71.4 mm		
Height	7.92 mm		
Style	Rectang		
Optic Material	PMMA		
Holder Material	-		
Fastening	Screw, pin		
Status	Ready		

Silicone sealed wide asymmetric street light array for road width

NOTE: The typical divergence will be changed by different color, chip size and chip position tolerance. The typical total divergence is the full angle measured where the luminous intensity is half of the peak value.



PRODUCT DATASHEET Strada-IP series

last update 17/4/2013

PHILIPS
LUMILEDS

GENERAL INFORMATION

- Product series especially designed & optimized for LUXEON Rebel ES series of LEDs.
- Special care taken to make light distribution as uniform as possible.
- Lens material optical grade PMMA with high UV and temperature resistance. Allows use of high current and temperature conditions.

Please find more information about used material from below:

http://ledil.fi/sites/default/files/Documents/Technical/Material/PMMA%20N%20UL94_Yellow%20Card.pdf

<http://ledil.fi/sites/default/files/Documents/Technical/Material/PMMA%20N%20PLEXIGLAS-Datasheet.pdf>

INDEX	PART NO	DESCRIPTION	MATERIAL
1	CS12862	STRADA-IP-2X6-DWC	PMMA 8N + Silicone seal

Top view

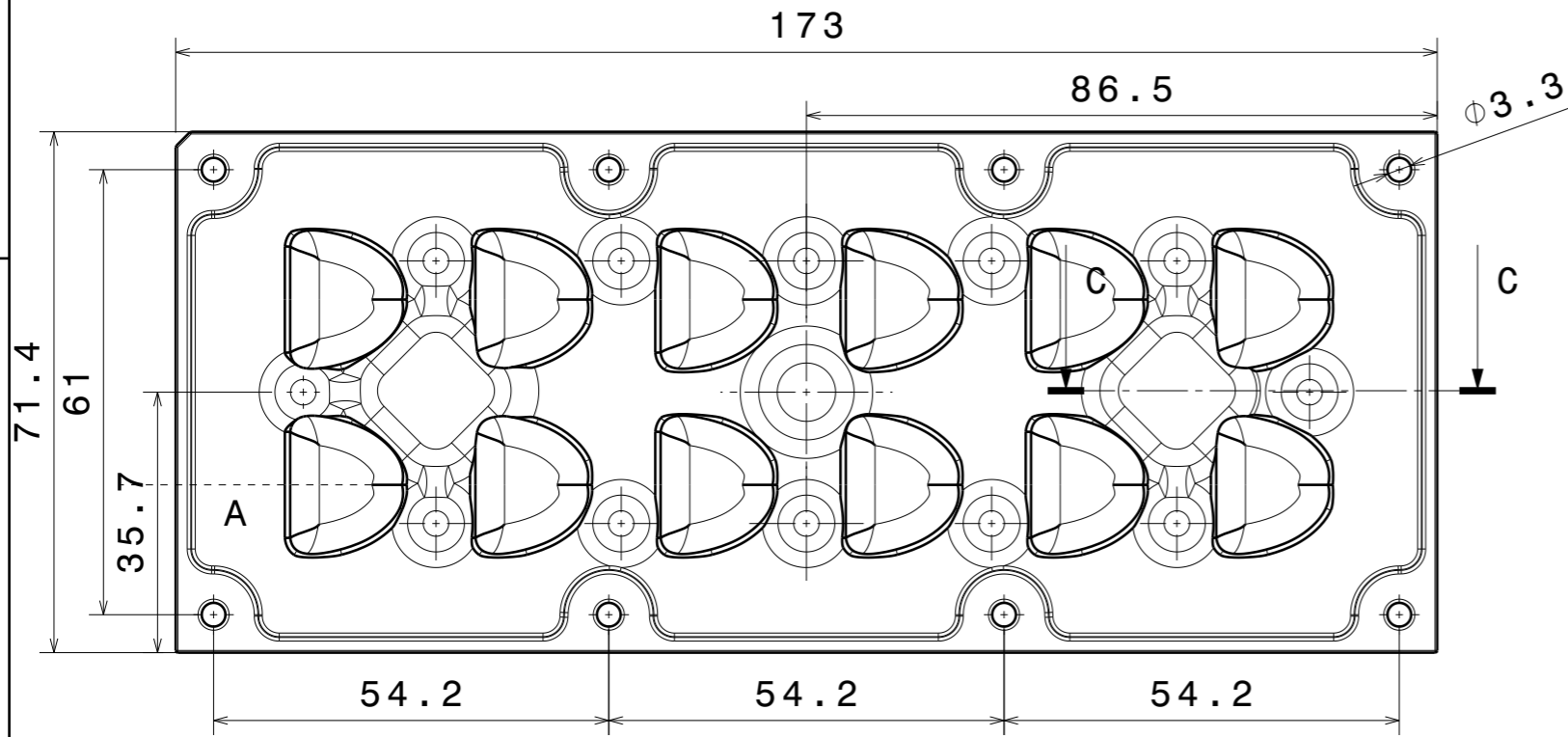

Cross section detail A

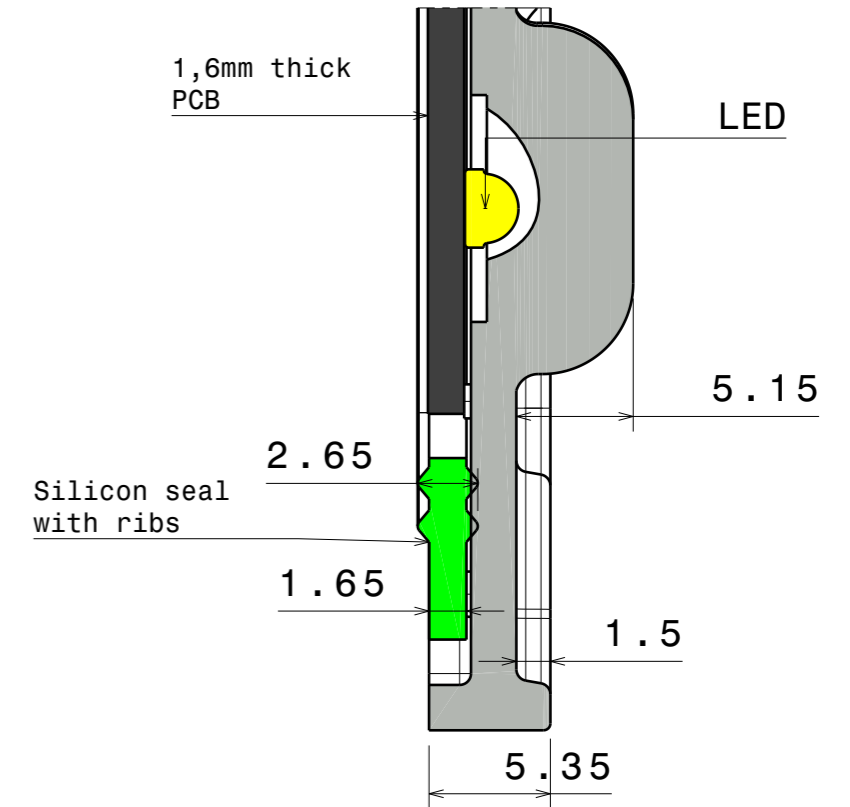

Section view C-C

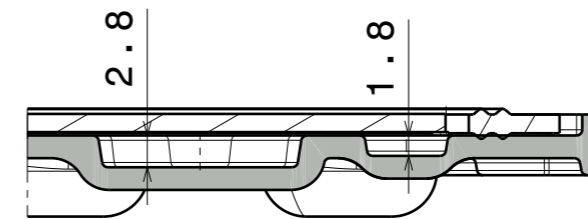

Pockets for wiring and screws

Bottom view

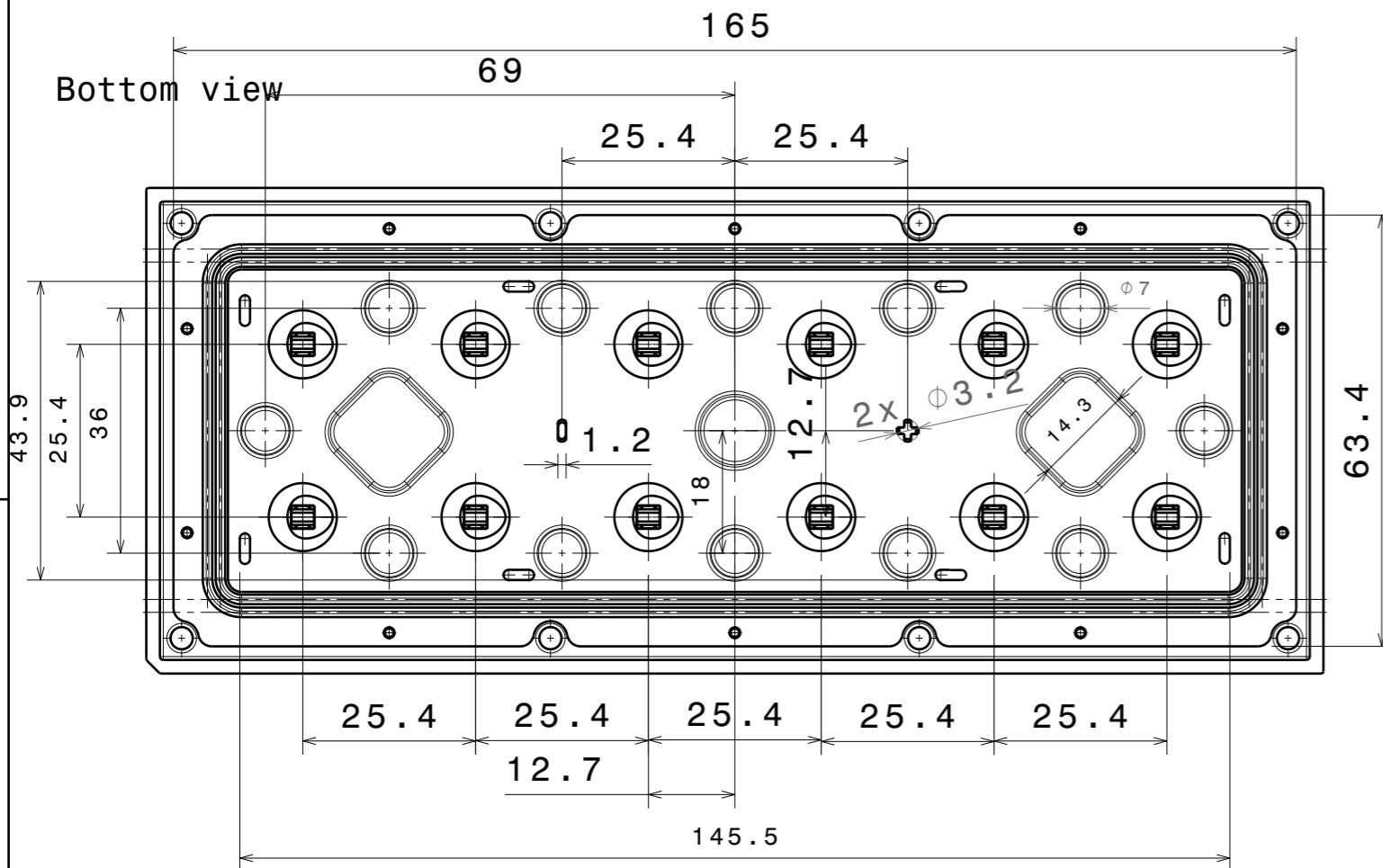

This drawing is our property. It can't be reproduced or communicated without our written agreement.		LEDiL LediL Oy Salorankatu 10 FIN 24240 SALO Finland	
DRAWN BY o1		DATE 7.9.2012	
CHECKED BY th		DATE 7.9.2012	
DESIGNED BY o1		DATE 1.8.2012	
DATASHEET DRAWING TITLE		Part Drawing	
CS12862 STRADA-IP-2X6-DWC		REV 002	
SIZE A3	PART NUMBER CS12862	WEIGHT 65,62 g	SHEET 1/2

INDEX	PART NO	DESCRIPTION	MATERIAL
1	CS12862	STRADA-IP-2X6-DWC	PMMA 8N + Silicone seal

Street side

8x Screws (M3) to mount the lens to heat sink.

Recommended torque with pan head screw: 0.57Nm (for 1.6mm thick PCB, no thermal pad)

Fasten middle screws first, then work toward outside corners, fastening screws on opposing sides until reaching corner screws.

Heatsink screw holes must be accurate to prevent twisting and cracks.

Recommended PCB:

1.6mm thick with no or minimum height thermal pad

Dimensions 43.5 x 145 mm

Ask LEDIL for layout suggestion and drawings.

Wiring:

PCB is fully sealed between the lens with silicone seal and the heatsink. Wiring needs to be done through the PCB and heat sink to maintain high IP rating.

Other notes:

Seal is tested to work in LEDiL's test assemblies. Customer is recommended to test the sealing in the end product due many variables, such as heat sink surface and possible chemical traces.

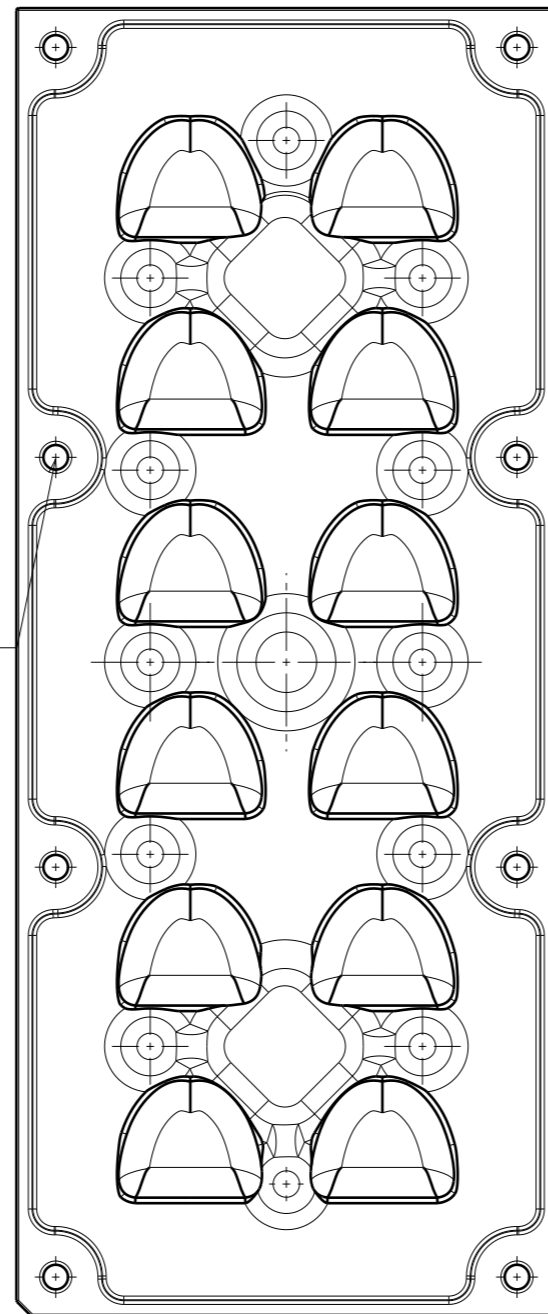

Top view

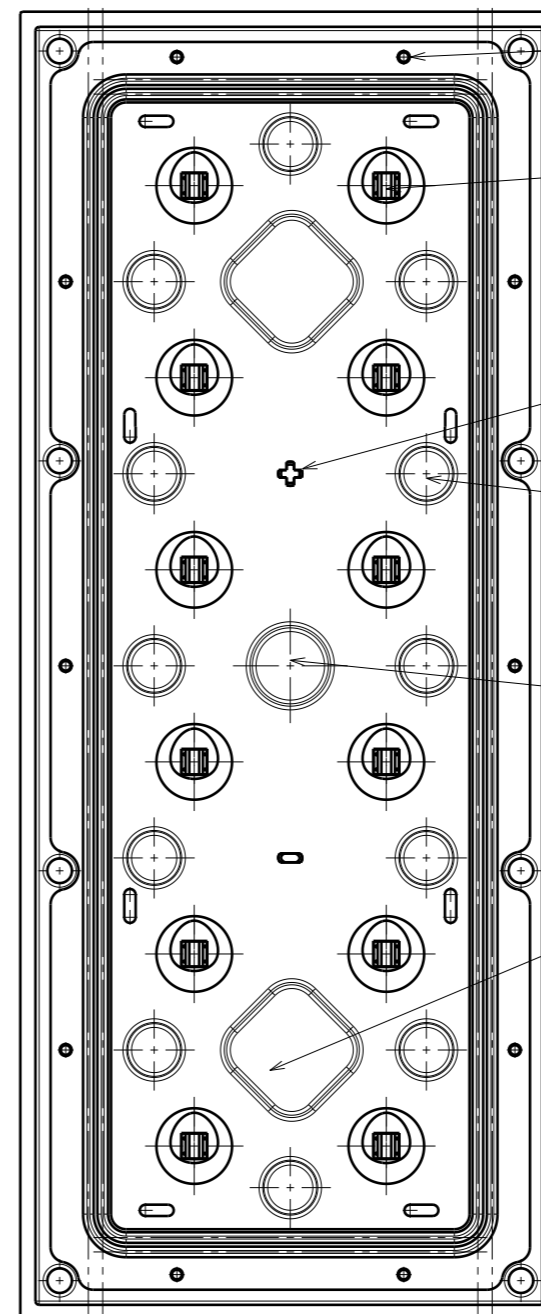

Bottom view

House side

10x Seal position pin grippers (check that the seal is attached during assembly)

12x LEDs

2x Position pins (for round PCB holes)

12x Pockets for PCB screws (M3)

Multifunction pocket (wiring, components or screws)

2 Pockets for PCB soldering

Cut corner as key element for correct alignment

This drawing is our property. It can't be reproduced or communicated without our written agreement.		 Ledil Oy Salorankatu 10 FIN 24240 SALO Finland	
DRAWN BY o1		DATE 7.9.2012	
CHECKED BY as		DATE 7.9.2012	
DESIGNED BY o1		DATE 1.8.2012	
DATASHEET DRAWING TITLE		Part Drawing	
CS12862 STRADA-IP-2X6-DWC		CS12862	
SIZE A3	PART NUMBER CS12862	REVISION 002	REV 002
SCALE 1:1	WEIGHT 65,62 g	SHEET 2/2	