

# Modicon TM2

## Analog I/O Modules

### Hardware Guide

05/2010



EIO0000000034.03

[www.schneider-electric.com](http://www.schneider-electric.com)

**Schneider**  
Electric

---

The information provided in this documentation contains general descriptions and/or technical characteristics of the performance of the products contained herein. This documentation is not intended as a substitute for and is not to be used for determining suitability or reliability of these products for specific user applications. It is the duty of any such user or integrator to perform the appropriate and complete risk analysis, evaluation and testing of the products with respect to the relevant specific application or use thereof. Neither Schneider Electric nor any of its affiliates or subsidiaries shall be responsible or liable for misuse of the information contained herein. If you have any suggestions for improvements or amendments or have found errors in this publication, please notify us.

No part of this document may be reproduced in any form or by any means, electronic or mechanical, including photocopying, without express written permission of Schneider Electric.

All pertinent state, regional, and local safety regulations must be observed when installing and using this product. For reasons of safety and to help ensure compliance with documented system data, only the manufacturer should perform repairs to components.

When devices are used for applications with technical safety requirements, the relevant instructions must be followed.

Failure to use Schneider Electric software or approved software with our hardware products may result in injury, harm, or improper operating results.

Failure to observe this information can result in injury or equipment damage.

© 2010 Schneider Electric. All rights reserved.

---

# Table of Contents



	<b>Safety Information</b> .....	<b>5</b>
	<b>About the Book</b> .....	<b>7</b>
<b>Chapter 1</b>	<b>General Overview and Rules for Implementing</b> .....	<b>11</b>
1.1	General Overview .....	12
	General Description .....	13
	Physical description .....	15
	Accessories .....	16
1.2	General Rules for Implementing .....	18
	Mounting Positions and Minimum Clearances .....	19
	Assembling a Module to a Controller .....	20
	Disassembling a Module from a Controller .....	22
	How to Install and Remove the Controller with its Expansions from a Mounting Rail .....	23
	How to Directly Mount a Module on a Panel Surface .....	25
	Wiring Requirements .....	26
	Grounding .....	28
<b>Chapter 2</b>	<b>Environmental Specifications of TM2 I/O Modules</b> .....	<b>31</b>
	Environmental Specifications of TM2 I/O Modules .....	31
<b>Chapter 3</b>	<b>TM2AMI2HT Analog Input Module</b> .....	<b>33</b>
	Presentation of the TM2AMI2HT Module .....	34
	Characteristics of the TM2AMI2HT Module .....	35
	Connecting the TM2AMI2HT Module .....	38
<b>Chapter 4</b>	<b>TM2AMI2LT Analog Input Module</b> .....	<b>39</b>
	Presentation of the TM2AMI2LT Module .....	40
	Characteristics of the TM2AMI2LT Module .....	41
	Connecting the TM2AMI2LT Module .....	44
<b>Chapter 5</b>	<b>TM2AMI4LT Analog Input Module</b> .....	<b>45</b>
	Presentation of the TM2AMI4LT Module .....	46
	Characteristics of the TM2AMI4LT Module .....	47
	Connecting the TM2AMI4LT Module .....	50

<b>Chapter 6</b>	<b>TM2AMI8HT Analog Input Module</b> .....	<b>53</b>
	Presentation of the TM2AMI8HT Module .....	54
	Characteristics of the TM2AMI8HT Module .....	55
	Connecting the TM2AMI8HT Module .....	58
<b>Chapter 7</b>	<b>TM2ARI8HT Analog Input Module</b> .....	<b>61</b>
	Presentation of the TM2ARI8HT Module .....	62
	Characteristics of the TM2ARI8HT Module .....	63
	Connecting the TM2ARI8HT Module .....	66
<b>Chapter 8</b>	<b>TM2ARI8LRJ Analog Input Module</b> .....	<b>69</b>
	Presentation of the TM2ARI8LRJ Module .....	70
	Characteristics of the TM2ARI8LRJ Module .....	71
	Connecting the TM2ARI8LRJ Module .....	75
<b>Chapter 9</b>	<b>TM2ARI8LT Analog Input Module</b> .....	<b>77</b>
	Presentation of the TM2ARI8LT Module .....	78
	Characteristics of the TM2ARI8LT Module .....	79
	Connecting the TM2ARI8LT Module .....	83
<b>Chapter 10</b>	<b>TM2AMO1HT Analog Output Module</b> .....	<b>85</b>
	Presentation of the TM2AMO1HT Module .....	86
	Characteristics of the TM2AMO1HT Module .....	87
	Connecting the TM2AMO1HT Module .....	90
<b>Chapter 11</b>	<b>TM2AVO2HT Analog Output Module</b> .....	<b>93</b>
	Presentation of the TM2AVO2HT Module .....	94
	Characteristics of the TM2AVO2HT Module .....	95
	Connecting the TM2AVO2HT Module .....	98
<b>Chapter 12</b>	<b>TM2AMM3HT Analog Mixed I/O Module</b> .....	<b>101</b>
	Presentation of the TM2AMM3HT Module .....	102
	Characteristics of the TM2AMM3HT Module .....	103
	Connecting the TM2AMM3HT Module .....	107
<b>Chapter 13</b>	<b>TM2AMM6HT Analog Mixed I/O Module</b> .....	<b>109</b>
	Presentation of the TM2AMM6HT Module .....	110
	Characteristics of the TM2AMM6HT Module .....	111
	Connecting the TM2AMM6HT Module .....	116
<b>Chapter 14</b>	<b>TM2ALM3LT Analog Mixed I/O Module</b> .....	<b>119</b>
	Presentation of the TM2ALM3LT Module .....	120
	Characteristics of the TM2ALM3LT Module .....	121
	Connecting the TM2ALM3LT Module .....	125
<b>Chapter 15</b>	<b>Certifications and Standards</b> .....	<b>127</b>
	Certifications and Standards .....	127
<b>Glossary</b>	.....	<b>129</b>
<b>Index</b>	.....	<b>135</b>

---

## Safety Information

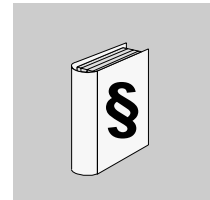

---

### Important Information

#### NOTICE

Read these instructions carefully, and look at the equipment to become familiar with the device before trying to install, operate, or maintain it. The following special messages may appear throughout this documentation or on the equipment to warn of potential hazards or to call attention to information that clarifies or simplifies a procedure.



The addition of this symbol to a Danger or Warning safety label indicates that an electrical hazard exists, which will result in personal injury if the instructions are not followed.



This is the safety alert symbol. It is used to alert you to potential personal injury hazards. Obey all safety messages that follow this symbol to avoid possible injury or death.

### **DANGER**

**DANGER** indicates an imminently hazardous situation which, if not avoided, **will result in** death or serious injury.

### **WARNING**

**WARNING** indicates a potentially hazardous situation which, if not avoided, **can result in** death or serious injury.

---

**⚠ CAUTION**

**CAUTION** indicates a potentially hazardous situation which, if not avoided, **can result in** minor or moderate injury.

**CAUTION**

**CAUTION**, used without the safety alert symbol, indicates a potentially hazardous situation which, if not avoided, **can result in** equipment damage.

**PLEASE NOTE**

Electrical equipment should be installed, operated, serviced, and maintained only by qualified personnel. No responsibility is assumed by Schneider Electric for any consequences arising out of the use of this material.

A qualified person is one who has skills and knowledge related to the construction and operation of electrical equipment and the installation, and has received safety training to recognize and avoid the hazards involved.

---

# About the Book

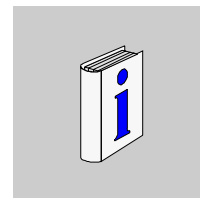

---

## At a Glance

### Document Scope

This guide describes the hardware implementation of TM2 Analog I/O Modules. It provides parts descriptions, specifications, wiring diagrams, installation, and setup for TM2 Analog I/O modules.

### Validity Note

The information in this manual is applicable **only** for TM2 products.

This document has been updated with the release of SoMachine V2.0.

The technical characteristics of the device(s) described in this manual also appear online. To access this information online:

Step	Action
1	Go to <a href="http://www.schneider-electric.com">www.schneider-electric.com</a>
2	In the <b>Search</b> box on the home page, type a model number. Do not type any blank spaces in the model number. To get information on a grouping similar modules, you can use the characters <b>**</b> ; do not use dots or <b>xx</b> 's.
3	Under <b>All</b> , click <b>Products</b> → <b>Product Datasheets</b> and select the model number that interests you.
4	To save or print a data sheet as a .pdf file, click <b>Export to PDF</b> .

The characteristics presented in this manual should be the same as those that appear online. In line with our policy of constant improvement we may revise content over time to improve clarity and accuracy. In the event that you see a difference between the manual and online information, use the online information as your reference.

---

## Related Documents

Title of Documentation	Reference Number
Modicon TM2 Expansion Modules Configuration Programming Guide	EIO0000000396 (ENG); EIO0000000397 (FRE); EIO0000000398 (GER); EIO0000000399 (SPA); EIO0000000400 (ITA); EIO0000000401 (CHS)
M238 Controller Hardware Guide	EIO000000016 (ENG); EIO000000017 (FRE); EIO000000018 (GER); EIO000000019 (SPA); EIO000000020 (ITA); EIO000000021 (CS)
TM2 Digital I/O Modules Instruction Sheet	AAV8177300

You can download these technical publications and other technical information from our website at [www.schneider-electric.com](http://www.schneider-electric.com).

## Product Related Information

 **DANGER**

**HAZARD OF ELECTRIC SHOCK, EXPLOSION OR ARC FLASH**

- Disconnect all power from all equipment including connected devices prior to removing any covers or doors, or installing or removing any accessories, hardware, cables, or wires except under the specific conditions specified in the appropriate hardware guide for this equipment.
- Always use a properly rated voltage sensing device to confirm the power is off where and when indicated.
- Replace and secure all covers, accessories, hardware, cables, and wires and confirm that a proper ground connection exists before applying power to the unit.
- Use only the specified voltage when operating this equipment and any associated products.

**Failure to follow these instructions will result in death or serious injury.**

---

## DANGER

### EXPLOSIVE POTENTIAL

- Only use this equipment in non-hazardous locations, or in locations that comply with Class I, Division 2, Groups A, B, C and D.
- Do not substitute components which would impair compliance to Class I Division 2.

**Failure to follow these instructions will result in death or serious injury.**

## WARNING

### LOSS OF CONTROL

- The designer of any control scheme must consider the potential failure modes of control paths and, for certain critical control functions, provide a means to achieve a safe state during and after a path failure. Examples of critical control functions are emergency stop and overtravel stop, power outage and restart.
- Separate or redundant control paths must be provided for critical control functions.
- System control paths may include communication links. Consideration must be given to the implications of unanticipated transmission delays or failures of the link.
- Observe all accident prevention regulations and local safety guidelines.<sup>1</sup>
- Each implementation of this equipment must be individually and thoroughly tested for proper operation before being placed into service.

**Failure to follow these instructions can result in death, serious injury, or equipment damage.**

<sup>1</sup> For additional information, refer to NEMA ICS 1.1 (latest edition), "Safety Guidelines for the Application, Installation, and Maintenance of Solid State Control" and to NEMA ICS 7.1 (latest edition), "Safety Standards for Construction and Guide for Selection, Installation and Operation of Adjustable-Speed Drive Systems" or their equivalent governing your particular location.

---

## **WARNING**

### **UNINTENDED EQUIPMENT OPERATION**

- Only use software approved by Schneider Electric for use with this equipment.
- Update your application program every time you change the physical hardware configuration.

**Failure to follow these instructions can result in death, serious injury, or equipment damage.**

### **User Comments**

We welcome your comments about this document. You can reach us by e-mail at [techcomm@schneider-electric.com](mailto:techcomm@schneider-electric.com).

---

# General Overview and Rules for Implementing

# 1

---

## Introduction

This chapter gives a general introduction and the rules for implementing the TM2 Analog I/O modules.

## What's in this Chapter?

This chapter contains the following sections:

Section	Topic	Page
1.1	General Overview	12
1.2	General Rules for Implementing	18

# 1.1 General Overview

---

## Introduction

This section gives a general introduction to the modules.

## What's in this Section?

This section contains the following topics:

Topic	Page
General Description	13
Physical description	15
Accessories	16

## General Description

### Introduction

The range of TM2 analog I/O modules includes:

- Input modules,
- Output modules,
- Mixed Input/Output modules.

The TM2 analog I/O modules are equipped with either screw terminal blocks, or RJ11 connectors (only for TM2ARI8LRJ).

### Module Features

The following table shows the analog I/O modules features, with corresponding channel type, voltage/current and terminal type:

Reference module	Channels	Channel type	Voltage/current	Terminal Type	Reference page
<b>Input Modules</b>					
TM2AMI2HT	2	High-level inputs	0...10 Vdc 4...20 mA	Removable screw terminal	<i>TM2AMI2HT Analog Input Module, page 33</i>
TM2AMI2LT	2	Low-level inputs	Thermocouple type J,K,T	Removable screw terminal	<i>TM2AMI2LT Analog Input Module, page 39</i>
TM2AMI4LT	4	Inputs	0...10 Vdc 0...20 mA PT100/1000 Ni100/1000	Removable screw terminal	<i>TM2AMI4LT Analog Input Module, page 45</i>
TM2AMI8HT	8	Inputs	0...20 mA 0...10 Vdc	Removable screw terminal	<i>TM2AMI8HT Analog Input Module, page 53</i>
TM2ARI8HT	8	Inputs	NTC / PTC	Removable screw terminal	<i>TM2ARI8HT Analog Input Module, page 61</i>
TM2ARI8LRJ	8	Inputs	PT100/1000	RJ11 connector	<i>TM2ARI8LRJ Analog Input Module, page 69</i>
TM2ARI8LT	8	Inputs	PT100/1000	Removable screw terminal	<i>TM2ARI8LT Analog Input Module, page 77</i>

Reference module	Channels	Channel type	Voltage/current	Terminal Type	Reference page
<b>Output Modules</b>					
TM2AMO1HT	1	Outputs	0...10 Vdc 4...20 mA	Removable screw terminal	<i>TM2AMO1HT Analog Output Module, page 85</i>
TM2AVO2HT	2	Outputs	+/- 10 Vdc	Removable screw terminal	<i>TM2AVO2HT Analog Output Module, page 93</i>
<b>Mixed Modules</b>					
TM2AMM3HT	2	Inputs	0...10 Vdc 4...20 mA	Removable screw terminal	<i>TM2AMM3HT Analog Mixed I/O Module, page 101</i>
	1	Outputs			
TM2AMM6HT	4	Inputs	0...10 Vdc 4...20 mA	Removable screw terminal	<i>TM2AMM6HT Analog Mixed I/O Module, page 109</i>
	2	Outputs			
TM2ALM3LT	2	Low-level inputs	Thermo J,K,T, PT100 0...10 Vdc 4...20 mA	Removable screw terminal	<i>TM2ALM3LT Analog Mixed I/O Module, page 119</i>
	1	Outputs			

## Physical description

### Introduction

This section describes the parts of Analog I/O modules, two with terminal block and one with 8 x RJ11 connectors. Your I/O module may differ from the illustrations but the parts will be the same.

### Illustration

The following pictures show the parts of Analog I/O modules:

TM2ALM3LT module  
with a terminal block

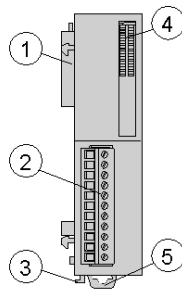

TM2ARI8LT module  
with 2 terminal blocks

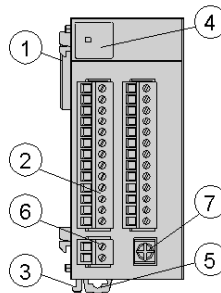

TM2ARI8LRJ module  
with 8 x RJ11 connectors

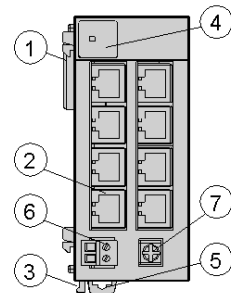

### Elements

The following table describes the different elements of Analog I/O modules shown above:

Label	TM2ALM3LT	TM2ARI8LT	TM2ARI8LRJ
1	Expansion connector for electrical connection (one on each side, right side not visible). It is designed to provide continuity of the electrical link between the modules connected.		
2	Terminal block (supplied with the module)	2 x Terminal block (supplied with the module)	8 x RJ11 Connectors
3	Locking device for attachment to the previous module		
4	LEDs for displaying the channels and module diagnostics		
5	Clip-on lock		
6	-	Power supply screw terminal block: 24 Vdc	
7	-	Screw for functional ground	

## Accessories

### Terminal Block End Clamp Type AB1AB8P35

Terminal Block End Clamps (reference AB1AB8P35) help reduce side-to-side movement of your controller and modules on the mounting rail. A controller and its associated modules are mounted on the mounting rail between two end clamps in order to improve the shock and vibration characteristics of the assembly.

The following picture shows a AB1AB8P35 Terminal Block End Clamp:

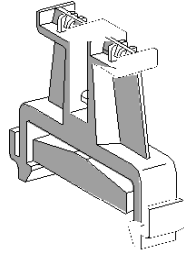

### The Mounting Rail

You can mount the controller and its expansion modules on a mounting rail. A mounting rail can be attached to a smooth mounting surface or suspended from an Electronic Industries Alliance (EIA) rack or in a Type 4 cabinet.

The following picture shows the different sizes of the mounting rail:

**AM1DE200**  
IEC/EN 60715

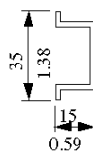

**AM1DP200**

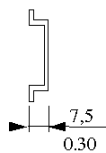

**AM1ED200**



**DZ5MB200**



You can order the suitable mounting rail from Schneider Electric:

Rail depth	Catalogue part number
15 mm (0.59 in.)	AM1DE200
7,5 mm (0.30 in.)	AM1DP200

**NOTE:** Do not use AM1ED200 and DZ5MB200.

### **TWDXMT5 Panel Mount Kit**

The following illustration shows a TWDXMT5 Panel Mount Kit which can be used instead of mounting rail to mount your controller and I/O modules directly to a panel:

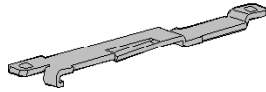

### **TM2XMTGB Grounding Bar**

The TM2XMTGB Grounding Bar is used to connect the shields of the cables and the functional ground of the modules to ground (*see page 28*).

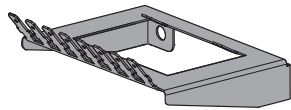

## 1.2 General Rules for Implementing

---

### Introduction

This section presents the information necessary to install and configure the modules, including mounting, wiring, and grounding requirements.

### What's in this Section?

This section contains the following topics:

Topic	Page
Mounting Positions and Minimum Clearances	19
Assembling a Module to a Controller	20
Disassembling a Module from a Controller	22
How to Install and Remove the Controller with its Expansions from a Mounting Rail	23
How to Directly Mount a Module on a Panel Surface	25
Wiring Requirements	26
Grounding	28

## Mounting Positions and Minimum Clearances

### Introduction

For mounting positions and minimum clearances, modules are mounted according to the rules defined for the hardware system that you associate with. Refer to the appropriate *Installation* chapter in the system *Hardware* documentation.

### **WARNING**

#### **UNINTENDED EQUIPMENT OPERATION**

- Place devices dissipating the most heat at the top of the cabinet and ensure adequate ventilation.
- Avoid placing this equipment next to or above devices that might cause overheating.
- Install the equipment in a location providing the minimum clearances from all adjacent structures and equipment as directed in this document.
- Install all equipment according to the drawings specified in the related documentation.

**Failure to follow these instructions can result in death, serious injury, or equipment damage.**

## Assembling a Module to a Controller

### Introduction

This section describes how to assemble a module to a controller.

After attaching new I/O modules to the controller, it is important to update and re-download your application program before placing the system back in service. If you do not revise your application program to reflect the addition of new modules, I/O located on the expansion bus may no longer operate normally.

### **WARNING**

#### **UNINTENDED EQUIPMENT OPERATION**

- Only use software approved by Schneider Electric for use with this equipment.
- Update your application program every time you change the physical hardware configuration.

**Failure to follow these instructions can result in death, serious injury, or equipment damage.**

### **DANGER**

#### **HAZARD OF ELECTRIC SHOCK, EXPLOSION OR ARC FLASH**

- Disconnect all power from all equipment including connected devices prior to removing any covers or doors, or installing or removing any accessories, hardware, cables, or wires except under the specific conditions specified in the appropriate hardware guide for this equipment.
- Always use a properly rated voltage sensing device to confirm the power is off where and when indicated.
- Replace and secure all covers, accessories, hardware, cables, and wires and confirm that a proper ground connection exists before applying power to the unit.
- Use only the specified voltage when operating this equipment and any associated products.

**Failure to follow these instructions will result in death or serious injury.**

## Assembling a Module to a Controller

The following procedure shows how to assemble a controller and a module together.

Step	Action
1	Remove all power and dismount any existing controller/IO assembly from its DIN/panel mounting.
2	Remove the expansion connector sticker from the controller or the outermost installed module.
3	Verify that the locking device ( <i>see page 15</i> ) on the new module is in the upper position.
4	Align the internal bus connector on the left side of the module with the internal bus connector on the right side of the controller or module.
5	Press the new module towards the controller or module until it "clicks" into place.
6	Push down the locking device ( <i>see page 15</i> ) on the top of the new module to lock it to the controller or previously installed module.

## Disassembling a Module from a Controller

### Introduction

This section describes how to disassemble a module from a controller.

** DANGER**

**HAZARD OF ELECTRIC SHOCK, EXPLOSION OR ARC FLASH**

- Disconnect all power from all equipment including connected devices prior to removing any covers or doors, or installing or removing any accessories, hardware, cables, or wires except under the specific conditions specified in the appropriate hardware guide for this equipment.
- Always use a properly rated voltage sensing device to confirm the power is off where and when indicated.
- Replace and secure all covers, accessories, hardware, cables, and wires and confirm that a proper ground connection exists before applying power to the unit.
- Use only the specified voltage when operating this equipment and any associated products.

**Failure to follow these instructions will result in death or serious injury.**

### Disassembling a Module from a Controller

The following procedure describes how to disassemble a module from a controller.

Step	Action
1	Remove all power from the control system.
2	Dismount the assembled controller and modules from the mounting rail or panel ( <i>see page 25</i> ).
3	Push up the locking device from the bottom of the module to disengage it from the controller.
4	Pull apart the controller and module.

## How to Install and Remove the Controller with its Expansions from a Mounting Rail

### Introduction

This section describes how to install and remove the controller with its expansions from a mounting rail.

**NOTE:** When mounting a controller and its modules on a mounting rail, use two terminal block end clamps of type AB1 AB8P35 or equivalent in order to improve the shock and vibration characteristics of the assembly.

### How to Install a Controller with its Expansions on a Mounting Rail

The following procedure describes how to install a controller with its expansions on a mounting rail.

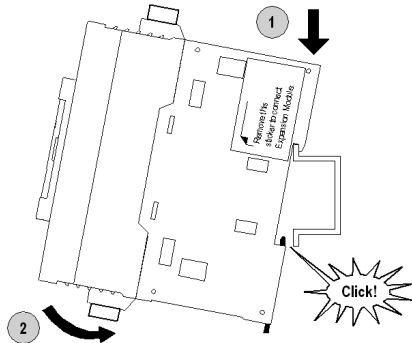
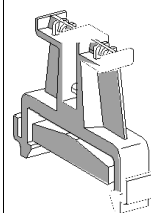
Step	Action
1	Fasten the mounting rail to a panel using screws.
2	Pull down the clip-on-lock at the bottom of the controller and module assembly. <div style="text-align: center;">  </div>
3	Put the top groove of the controller and modules on the mounting rail and press the assembly toward the mounting rail.
4	Push the clip-on lock of the module into the mounting rail.
5	Place two terminal block end clamps on both sides of the controller and module assembly to help minimize side-to-side movement. <div style="text-align: center;">  </div>

## How to Remove a Controller with its Expansions from a Mounting Rail

The following procedure describes how to remove a controller with its expansions from a mounting rail.

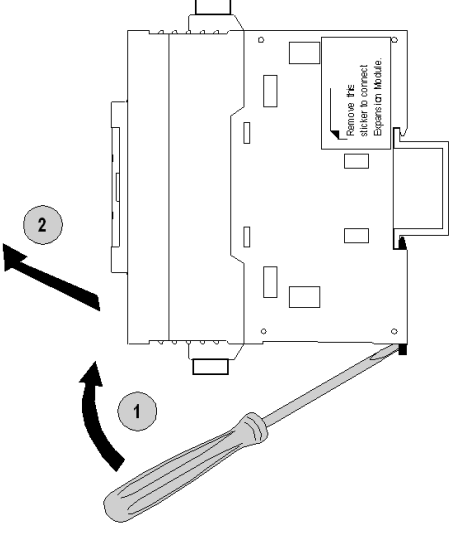
Step	Action
1	Insert a flat screwdriver into the slot in the clip-on-lock. 
2	Pull down the clip-on lock.
3	Tilt and lift the controller and its associated modules off of the mounting rail from the bottom.

## How to Directly Mount a Module on a Panel Surface

### Introduction

This section shows how to install your module using the Panel Mounting Kit. This section also provides mounting hole layout for all modules. Your module may differ from the module appearing in these illustrations but the procedure is still applicable.

### Installing the Panel Mount Kit

The following procedure shows how to install a mounting strip.

Step	Action
1	Remove the clip-on-lock from the back side of the module by pushing the clip-on lock upwards.
2	Insert the mounting strip, with the hook entering last, into the slot where the clip-on lock was removed.
3	Slide the mounting strip into the slot until the hook enters into the recess in the module.

The following illustration shows how to attach the TWD XMT5 Panel Mount Kit to a module:

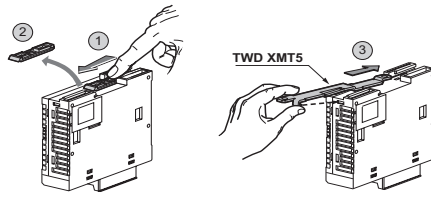

### Mounting Hole Layout for Modules

The following diagram shows the mounting hole layout for all modules.

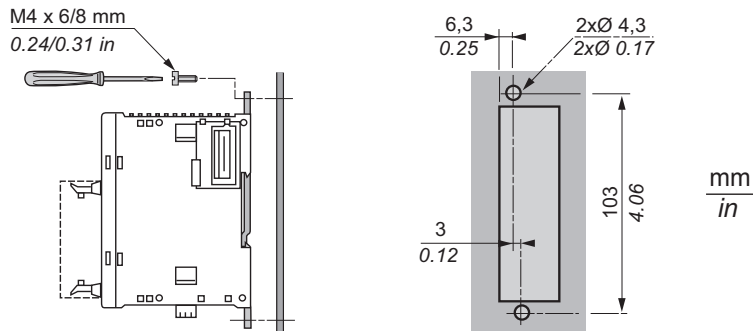

## Wiring Requirements

### Introduction

There are several rules that must be followed when wiring a TM2 I/O module.

For modules that have more than one terminal block or connector that is identical, any of them can be potentially plugged into any socket.

Despite the indicators on the terminal blocks, connectors and modules, it is possible to incorrectly install the terminal blocks or connectors and create incorrect wiring.

Plugging a connector into the wrong socket could cause unintended behavior of the application.

### **DANGER**

#### **UNINTENDED EQUIPMENT OPERATION OR ELECTRIC SHOCK**

Be sure to connect the terminal blocks to their designated location.

**Failure to follow these instructions will result in death or serious injury.**

**NOTE:** Clearly and uniquely label each terminal block and connector with an appropriate system of identification.

### Rules

### **DANGER**

#### **HAZARD OF ELECTRIC SHOCK, EXPLOSION OR ARC FLASH**

- Disconnect all power from all equipment including connected devices prior to removing any covers or doors, or installing or removing any accessories, hardware, cables, or wires except under the specific conditions specified in the appropriate hardware guide for this equipment.
- Always use a properly rated voltage sensing device to confirm the power is off where and when indicated.
- Replace and secure all covers, accessories, hardware, cables, and wires and confirm that a proper ground connection exists before applying power to the unit.
- Use only the specified voltage when operating this equipment and any associated products.

**Failure to follow these instructions will result in death or serious injury.**

The following rules must be applied when wiring the analog I/O modules:

- I/O and communication wiring must be kept separate from the power wiring. Route these 2 types of wiring in separate cable ducting.
- Verify that the operating conditions and environment are within the specification values.
- Use proper wire sizes to meet voltage and current requirements.
- Use copper conductors only.
- Use twisted-pair, shielded cables for analog, expert and/or fast I/O.
- Use twisted-pair, shielded cables for networks and field bus (CANopen, serial, Ethernet).

## ⚠ WARNING

### UNINTENDED EQUIPMENT OPERATION

- Use shielded cables for all input, output and communication types specified above.
- Properly ground the cable shields as indicated in the related documentation.
- Route communications and I/O cables separately from power cables.

**Failure to follow these instructions can result in death, serious injury, or equipment damage.**

For more details, refer to Grounding (*see page 28*).

The following table shows the cable types and wire sizes for removable screw terminal block:

mm <sup>2</sup>	0,14...1,5	0,25...0,5	0,25...1,5	0,14...0,5	0,14...0,75	0,25...0,34	0,5
AWG	26...16	24...20	24...16	26...20	26...18	24...22	20

<p>Ø 2,5 mm (0.10 in)</p>		<p>N•m</p> <p>lb-in.</p>	<p>0,23</p> <p>2,0</p>
---------------------------	--	--------------------------	------------------------

Use copper conductors only

Applying torque above the limit may damage the terminal screw or threads.

## CAUTION

### INOPERABLE EQUIPMENT

Do not tighten screw terminals beyond the specified maximum torque (Nm / lb-in.).

**Failure to follow these instructions can result in equipment damage.**

## Grounding

### Presentation

Electromagnetic radiation may interfere with control communications and/or input/output signals to the control system.

### **WARNING**

#### **UNINTENDED EQUIPMENT OPERATION**

- Use shielded cables wherever specified for inputs, outputs and communication connections.
- Properly ground the cable shields as indicated in the related documentation.
- Route communication and I/O cables separately from power cables.

**Failure to follow these instructions can result in death, serious injury, or equipment damage.**

### **WARNING**

#### **INACCURATE ANALOG CONVERSIONS**

Make sure that an appropriate, braided ground cable is attached to the ground terminal of the module and securely attached to the protective ground connection of your system.

**Failure to follow these instructions can result in death, serious injury, or equipment damage.**

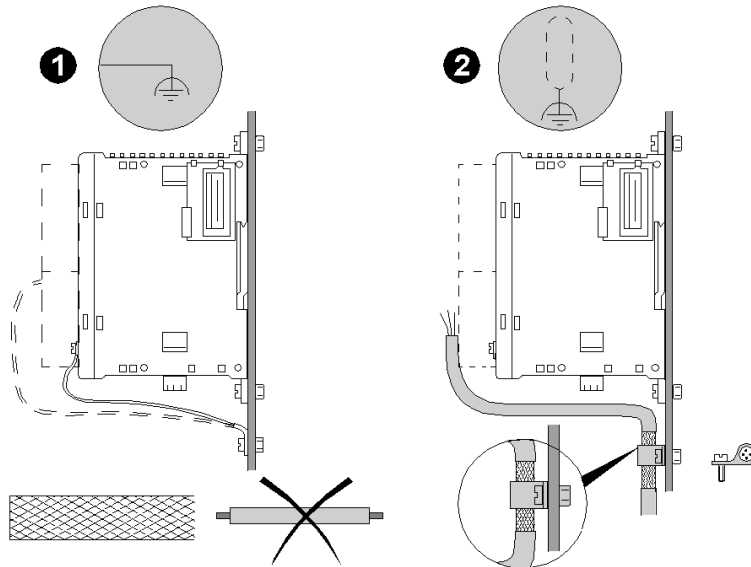

N°	Signification	Description
1	Grounding of the module	Connect the module to the functional ground (FE) terminal with the braided cable supplied with the module.
2	Grounding of the sensor	<p>Attach and ground the shielding of cables as close as possible to the controller base:</p> <ul style="list-style-type: none"> <li>● Strip the shielding</li> <li>● Attach the cable to the metal support by attaching the clamp to the stripped part of the shielding.</li> </ul> <p>The shielding must be clamped tightly enough to the metal support to permit good contact.</p>

## Grounding Bar TM2XMTGB

The figure below shows how to connect the grounding bar TM2XMTGB:

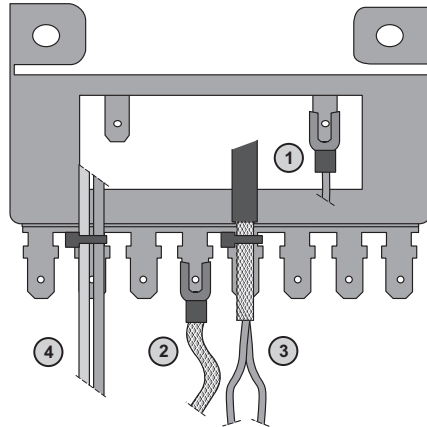

- 1 Controller functional grounding
- 2 Modules functional grounding
- 3 Analog fast I/O cable shielding
- 4 Cable attachment

**NOTE:** Schneider Electric recommends the use of the TM2XMTGB Grounding Bar for use with TM2 I/O modules.

### **⚠ WARNING**

#### **ACCIDENTAL DISCONNECTION FROM PROTECTIVE GROUND (PE)**

- Do not use the TM2 XMTGB Grounding Bar to provide a protective ground (PE)..
- Use the TM2 XMTGB Grounding Bar only to provide a functional ground (FE).

**Failure to follow these instructions can result in death, serious injury, or equipment damage.**

---

# Environmental Specifications of TM2 I/O Modules

# 2

---

## Environmental Specifications of TM2 I/O Modules

### TM2 I/O Modules Environmental Specifications

All the TM2 Analog I/O modules are electrically isolated with the use of a photocoupler between the internal electronic circuit and the input/output channels.

### **WARNING**

#### **UNINTENDED EQUIPMENT OPERATION**

Do not exceed any of the rated values specified in the following tables.

**Failure to follow these instructions can result in death, serious injury, or equipment damage.**

<b>TM2 I/O Modules Climatic and Mechanical Specifications</b>		
Temperature	Operation	0 ... 55°C (32 ... 31°F)
	Storage	- 25 ... 70°C (-13 ... 158°F)
Relative humidity		30 ... 95 % (non-condensing)
Degree of pollution		2 (IEC 60664)
Degree of protection		IP 20 (IEC 60529)
Corrosion immunity		Free from corrosive gases
Altitude	Operation	0 ... 2000 m (0 ... 6,560 ft))
	Storage	0 ... 3000 m (0 ... 9,840 ft)

<b>TM2 I/O Modules Climatic and Mechanical Specifications</b>		
Vibration resistance	Mounted on a mounting rail	3.5 mm fixed amplitude from 5 ... 8.5 Hz 9.8 m/s <sup>2</sup> (1 g <sub>n</sub> ) fixed acceleration from 8.5 ... 150 Hz
	Plate or panel mounted	10 mm fixed amplitude from 5 ... 8.7 Hz 29.4 m/s <sup>2</sup> (3 g <sub>n</sub> ) fixed acceleration from 8.5 ... 150 Hz
Mechanical shock resistance		147 m/s <sup>2</sup> (15g) for 11 ms duration

<b>TM2 I/O Modules EMC Specifications</b>	
Electrostatic discharge IEC/EN 61000-4-2	8 kV (air discharge) 6 kV (contact discharge)
Radiated electromagnetic field IEC/EN 61000-4-3	10 V/m (80 MHz... 2 GHz) 1 V/m (2... 2.7 GHz)
Magnetic field IEC/EN 61000-4-8	30 A/m
Fast Transient Burst IEC/EN 61000-4-4	Power supply: 2 kV I/O: 1 kV shielded cable: 1 kV Repetition rate: 5 and 100 kHz
Induced electromagnetic field IEC/EN 61000-4-6	10 V <sub>eff</sub> (0.15...80 MHz)
Surge immunity IEC/EN 61000-4-5 24 Vdc circuit:	1 kV in Common mode 0.5 kV in differential mode
Conducted emissions	Class A: according to EN 55022/55011 150 kHz...500 kHz quasi peak 79 dB μV 500 kHz...30 MHz quasi peak 73 dBμV
Radiated emissions	Class A: according to EN 55022/55011 d= 10 m (32.81 ft.) 30 MHz...230 MHz quasi peak 40 dB μV Class A: according to EN 55022/55011 d= 10 m (32.81 ft.) 230 MHz...2 GHz quasi peak 47 dB μV

---

# TM2AMI2HT Analog Input Module

# 3

---

## Overview

This chapter describes the **TM2AMI2HT** module, its characteristics and its connection to the different sensors.

## What's in this Chapter?

This chapter contains the following topics:

Topic	Page
Presentation of the TM2AMI2HT Module	34
Characteristics of the TM2AMI2HT Module	35
Connecting the TM2AMI2HT Module	38

## Presentation of the TM2AMI2HT Module

### Main Specifications

<b>TM2AMI2HT Main Specifications</b>		
Number of input channels	2	
Signal type	Voltage	Current
Input range	0...10 Vdc (non differential)	4....20 mA (non differential)
Resolution	12 bits (4096 points)	
Connection type	Removable screw terminal block	

## Characteristics of the TM2AMI2HT Module

### Introduction

This section provides a description of the electrical and the input characteristics of the **TM2AMI2HT** module.

### **⚠ DANGER**

#### **FIRE HAZARD**

Use only the recommended wire sizes for I/O channels and power supplies.

**Failure to follow these instructions will result in death or serious injury.**

### **⚠ WARNING**

#### **UNINTENDED EQUIPMENT OPERATION**

Do not exceed any of the rated values specified in the following tables.

**Failure to follow these instructions can result in death, serious injury, or equipment damage.**

### Dimensions

The following diagrams show the dimensions for the TM2AMI2HT analog I/O module.

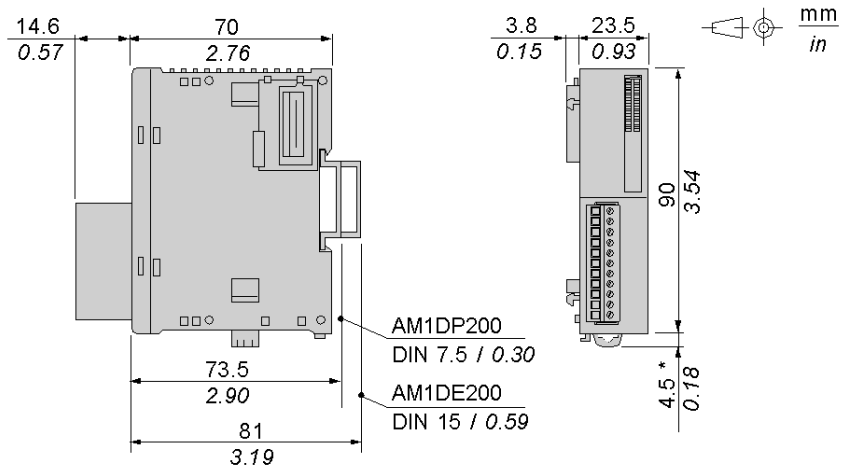

**NOTE:** \* 8.5 mm (0.33 in) when the clip-on lock is pulled out.

### General characteristics

The following table shows the general characteristics of the **TM2AMI2HT** module:

Characteristic	Specification
Rated power supply voltage	24 Vdc
Power supply range	20.4...28.8 Vdc
Connector insertion/removal durability	100 times minimum
Internal 5 Vdc current draw	50 mA
Internal 24 Vdc current draw	0 mA
External 24 Vdc current draw	60 mA
Weight	85 g (3 oz)

### Inputs characteristics

The following table shows the inputs characteristics of the **TM2AMI2HT** module:

Characteristic	Voltage input	Current input
Input range	0...10 Vdc	4...20 mA
Input impedance	1 M $\Omega$ min.	10 $\Omega$
Sample duration time	10 ms max.	
Total input system transfer time	2 x 10 ms + 1 scan time <sup>1</sup>	
Input type	Non differential	Non differential
Operating mode	Self-scan	
Conversion mode	$\Sigma\Delta$ type ADC	
Input tolerance - maximum deviation at ambient 25° C (77°F)	$\pm 0.2$ % of full scale	
Input tolerance - temperature drift	$\pm 0.006$ % of full scale/° C	
Input deviation - repeatable after stabilization time	$\pm 0.5$ % of full scale	
Input tolerance - nonlinear	$\pm 0.2$ % of full scale	
Input tolerance - maximum deviation	$\pm 1$ % of full scale	
Digital resolution	4096 increments (12 bits)	
Input value of LSB	2.5 mV	4.8 $\mu$ A
Data type in application program	0 to 4095 (12 bit data) Custom range up to -32768 to 32767 <sup>2</sup>	

Characteristic	Voltage input	Current input
Input data out of range detection	Yes <sup>3</sup>	
Noise resistance - maximum temporary deviation during perturbations	±3 % maximum when EMC perturbation is applied to the power and I/O wiring	
Noise resistance - cable	Twisted-pair shielded cable is necessary	
Noise resistance - crosstalk	2 LSB maximum	
Isolation between external power supply and inputs	500 Vac	
Isolation between inputs and logic circuits	Photocoupler between input and internal circuit (2500 Vac by photocoupler isolation)	
Maximum continuous allowed overload (no damage)	13 Vdc	40 mA
Selection of analog input signal type	Using software programming	
Calibration or verification to maintain rated accuracy	Approximately 10 years	

**NOTE:**

1. Total input system transfer time = sample repetition x active channel number + 1 scan time.
2. The 12-bit data (0 to 4095) processed in the Analog I/O module can be linear-converted to a value between -32768 and 32767. The optional range designation and analog I/O data minimum and maximum values can be selected using data registers allocated to analog I/O modules.
3. When an input error is detected, a corresponding error code is stored to a data register allocated to analog I/O operating status.

## Connecting the TM2AMI2HT Module

### Wiring Rules

See Wiring Rules and Recommendations (*see page 26*).

### TM2AMI2HT Wiring Diagram

The following diagram shows the connection of the inputs module.

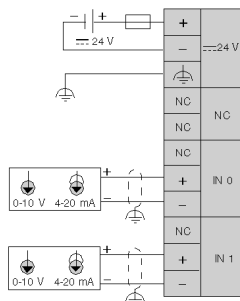

Use the braid supplied with the module to connect the functional ground

- Connect an appropriate fuse for the applied voltage and current draw, at the position shown in the diagram.

**NOTE:** The (-) poles of inputs IN0 and IN1 are connected internally.

## **⚠ WARNING**

### **UNINTENDED EQUIPMENT OPERATION**

- Use shielded cables wherever specified for inputs, outputs and communication connections.
- Properly ground the cable shields as indicated in the related documentation.
- Route communication and I/O cables separately from power cables.

**Failure to follow these instructions can result in death, serious injury, or equipment damage.**

## **⚠ WARNING**

### **UNINTENDED EQUIPMENT OPERATION**

Do not connect wires to unused terminals or terminals marked “Not Connected (N.C.)”.

**Failure to follow these instructions can result in death, serious injury, or equipment damage.**

---

# TM2AMI2LT Analog Input Module

# 4

---

## Overview

This chapter describes the **TM2AMI2LT** module, its characteristics and its connection to the different sensors.

## What's in this Chapter?

This chapter contains the following topics:

Topic	Page
Presentation of the TM2AMI2LT Module	40
Characteristics of the TM2AMI2LT Module	41
Connecting the TM2AMI2LT Module	44

## Presentation of the TM2AMI2LT Module

### Main Specifications

<b>TM2AMI2LT Main Specifications</b>	
Number of input channels	2
Sensor type	Thermocouple
Input type	Type K: -200...760° C (-328...1400° F) Type J: -270...1370° C (-454...2498° F) Type T: -270...400° C (-270...752° F)
Resolution	12 bits (4096 points)
Connection type	Removable screw terminal block

## Characteristics of the TM2AMI2LT Module

### Introduction

This section provides a description of the electrical and the input characteristics of the **TM2AMI2LT** module.

### **⚠ DANGER**

#### **FIRE HAZARD**

Use only the recommended wire sizes for I/O channels and power supplies.

**Failure to follow these instructions will result in death or serious injury.**

### **⚠ WARNING**

#### **UNINTENDED EQUIPMENT OPERATION**

Do not exceed any of the rated values specified in the following tables.

**Failure to follow these instructions can result in death, serious injury, or equipment damage.**

### Dimensions

The following diagrams show the dimensions for the TM2AMI2LT analog I/O module.

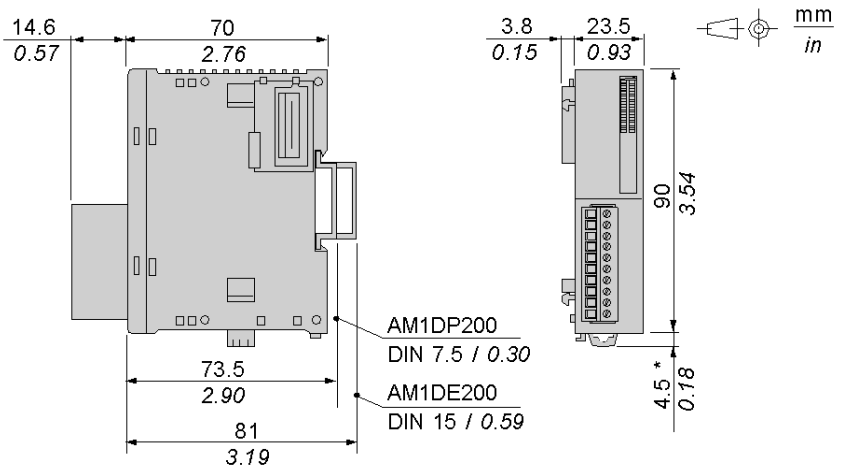

**NOTE:** \* 8.5 mm (0.33 in) when the clip-on lock is pulled out.

### General Characteristics

The following table shows the general characteristics of the **TM2AMI2LT** module:

<b>TM2AMI2LT Electrical characteristics</b>	
Rated power supply voltage	24 Vdc
Power supply range	20.4...28.8 Vdc
Connector insertion/removal durability	100 times minimum
Internal 5 Vdc current draw	100 mA
Internal 24 Vdc current draw	0 mA
External 24 Vdc current draw	21 mA (inrush, 30 mA)
Weight	85 g (3 oz)

### I/O Characteristics

The following table shows the input characteristics of the **TM2AMI2LT** module:

<b>Characteristic</b>	<b>Specification</b>
Input range	Type K: -270...+1370 °C (-454...+2498 °F) Type J: -200...+760 °C (-328...+1400 °F) Type T: -270...+400 °C (-454...+752 °F)
Input impedance	1 MΩ min.
Sample duration time	200 ms
Total input system transfer time	400 ms + 1 scan time
Input type	Differential input
Operating mode	Self-scan
Conversion mode	ΣΔ ADC 16 bits
Maximum overload on input channel	±7.5 Vdc
Input tolerance - maximum deviation at 25°C (77°F)	0.2 % + temperature correction total error K, J, T: ±5 °C
Input tolerance - temperature drift	±0.006 % of full scale/°C
Input tolerance - repeatable after stabilization time	±0.5 % of full scale
Input tolerance - nonlinear	±0.2 % of full scale
Input tolerance- maximum deviation	±1 % of full scale
Digital resolution	Type T: 13 bits Type J, K: 14 bits
Input value of LSB	0.1 °C (0.18 °F)

Characteristic	Specification
Data type in application program	0 to 4095 (Standard) -32768 to 32767 (Custom) Celsius Fahrenheit
Input data out of range detection	Yes <sup>1</sup>
Noise resistance - maximum temporary deviation during perturbations	±1 % maximum
Noise resistance - cable	Twisted-pair shielded cable is necessary
Noise resistance - crosstalk	2 LSB maximum
Isolation between inputs	None
Isolation between inputs and logic circuits	2500 Vac, by photocoupler
Isolation between external power supply and inputs	500 Vac
Selection of analog input signal type	Using software programming
Calibration or verification to maintain rated accuracy	Approximately 10 years
50/60 Hz rejection and filtering	50/60 Hz: 120 dB rejection typ. (common mode) 60 dB rejection typ. (differential mode) Numeric filtering function by firmware
Temperature drift	30 ppm/°C
Cold junction compensation	Internal temperature sensor
Default input value in case of sensor disconnection	Ambiant temperature of the module

**NOTE:**

1. Total input system transfer time = sample repetition x active channel number + 1 scan time.
2. The 12-bit data (0 to 4095) processed in the Analog I/O module can be linear-converted to a value between -32768 and 32767. The optional range designation and analog I/O data minimum and maximum values can be selected using data registers allocated to analog I/O modules.
3. When an input error is detected, a corresponding error code is stored to a data register allocated to analog I/O operating status.

## Connecting the TM2AMI2LT Module

### Wiring Rules

See Wiring Rules and Recommendations (*see page 26*).

### TM2AMI2LT Wiring Diagram

The following diagram shows the connection of the module inputs.

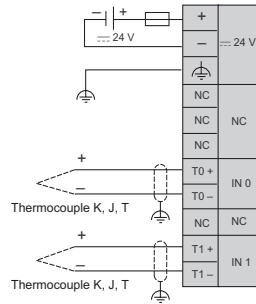

(1) Thermocouple K, J, T

To use the braid supplied with the module to connect the functional ground

- Connect an appropriate fuse for the applied voltage and current draw, at the position shown in the diagram.

## **⚠ WARNING**

### **UNINTENDED EQUIPMENT OPERATION**

- Use shielded cables wherever specified for inputs, outputs and communication connections.
- Properly ground the cable shields as indicated in the related documentation.
- Route communication and I/O cables separately from power cables.

**Failure to follow these instructions can result in death, serious injury, or equipment damage.**

## **⚠ WARNING**

### **UNINTENDED EQUIPMENT OPERATION**

Do not connect wires to unused terminals or terminals marked “Not Connected (N.C.)”.

**Failure to follow these instructions can result in death, serious injury, or equipment damage.**

---

# TM2AMI4LT Analog Input Module

# 5

---

## Overview

This chapter describes the **TM2AMI4LT** module, its characteristics and its connection to the different sensors.

## What's in this Chapter?

This chapter contains the following topics:

Topic	Page
Presentation of the TM2AMI4LT Module	46
Characteristics of the TM2AMI4LT Module	47
Connecting the TM2AMI4LT Module	50

## Presentation of the TM2AMI4LT Module

### Main Specifications

<b>TM2AMI4LT Main Specifications</b>			
Number of input channels	4		
Signal/sensor type	Voltage	Current	Temperature
Input type	0...10 Vdc (non differential)	0....20 mA (non differential)	PT100/1000 Ni100/1000
Resolution	12 bits (4096 points)		
Connection type	Removable screw terminal block		

## Characteristics of the TM2AMI4LT Module

### Introduction

This section provides a description of the electrical and the input characteristics of the **TM2AMI4LT** module.

### **⚠ DANGER**

#### **FIRE HAZARD**

Use only the recommended wire sizes for I/O channels and power supplies.

**Failure to follow these instructions will result in death or serious injury.**

### **⚠ WARNING**

#### **UNINTENDED EQUIPMENT OPERATION**

Do not exceed any of the rated values specified in the following tables.

**Failure to follow these instructions can result in death, serious injury, or equipment damage.**

### Dimensions

The following diagrams show the dimensions for the TM2 AMI4LT analog I/O module.

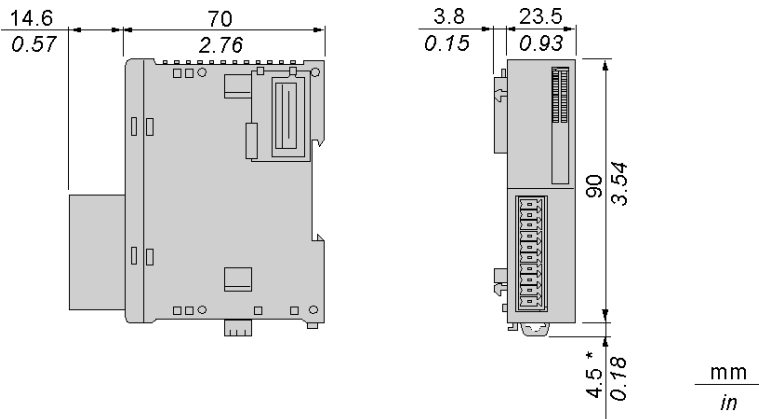

**NOTE:** \* 8.5 mm (0.33 in) when the clip-on lock is pulled out.

### General Characteristics

The following table shows the general characteristics of the **TM2AMI4LT** module:

Characteristic	Specification
Rated power supply voltage	24 Vdc
Power supply range	19.2...30 Vdc including ripple
Connector insertion/removal durability	100 times minimum
Internal 5 Vdc current draw	50 mA
Internal 24 Vdc current draw	0 mA
External 24 Vdc current draw	60 mA
Weight	85 g (3 oz)

### Inputs Characteristics

The following table shows the inputs characteristics of the **TM2AMI4LT** module.

Characteristic	Voltage input	Current input	Temperature probe input
Input range	0...10 Vdc	0...20 mA	(RTD) Pt 100, Pt 1000, Ni 100, Ni 1000 3-wire type Pt sensor -200...600 °C (-328...1112 °F) Ni sensor -50...150 °C (-58...302 °F)
Input impedance	> 10 kΩ	< 250 Ω	> 10 kΩ
Sample duration time	160 ms		
Total input system transfer time	4x160 ms + 1 scan time		8x160 ms + 1 scan time
Input type	Non differential		
Operating mode	Self-scan		
Conversion mode	ΣΔ type ADC		
Input tolerance - maximum deviation at 25°C (77°F)	±0.2 % of full scale ± 0.4 % temperature probe input		
Input tolerance - temperature drift	±0.005 % of full scale/°C		
Input tolerance - repeatable after stabilization time	± 0.1% of full scale		
Input tolerance - nonlinear	±0.02 % of full scale		

Characteristic	Voltage input	Current input	Temperature probe input
Input tolerance - maximum deviation	±0.5 % of full scale		
Digital resolution	4096 increments (12 bits)		
Input value of LSB	2.5 mV	4.8 µA	K: 0.15 °C (K: 0.27 °F)
Data type in application program	0 to 4095 (12 bit) Custom range up to -32768 to 32767 <sup>2</sup>		
Input data out of range detection	Yes <sup>3</sup>		
Noise resistance - cable	Twisted-pair shielded cable is necessary for improved noise immunity		
Noise resistance - external crosstalk	1 LSB maximum		
Isolation between inputs, external power supply and internal logic circuits	2500 Vac by photocoupler		
Isolation between inputs	None		
Type of protection	Photocoupler between input and internal circuit (1500 Vdc isolation)		
Maximum continuous allowed overload (no damage)	13 Vdc	40 mA	–
Selection of analog input signal type	Using software programming <b>NOTE:</b> All inputs have the same voltage/current configuration or temperature. For temperature, it is possible to configure each channel independently of the type of probe.		
Calibration or verification to maintain rated accuracy	Approximately 10 years		
Default input value in case of temperature sensor disconnectio	Upper limit		

**NOTE:**

1. Total input system transfer time = sample repetition x 2 + 1 scan time.
2. The 12-bit data (0 to 4095) processed in the Analog I/O module can be linearly converted to a value between -32768 and 32767. The optional range designation and analog I/O data minimum and maximum values can be selected using data registers allocated to analog I/O modules.
3. When an input error is detected, a corresponding error code is stored to a data register allocated to analog I/O operating status.

## Connecting the TM2AMI4LT Module

### Wiring Rules

See Wiring Rules and Recommendations (*see page 26*).

### TM2AMI4LT Wiring Diagram

This wiring diagram is for inputs configured for measuring temperature.

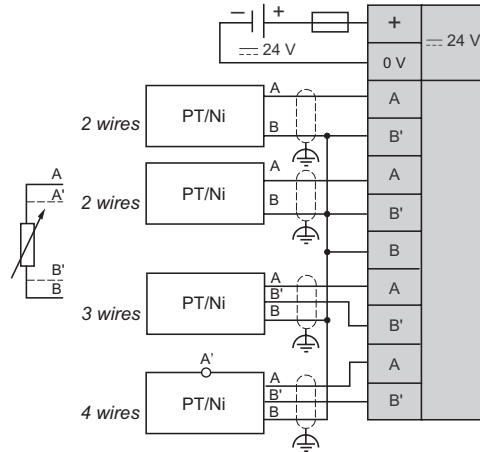

This wiring diagram is for inputs configured for measuring voltage/current.

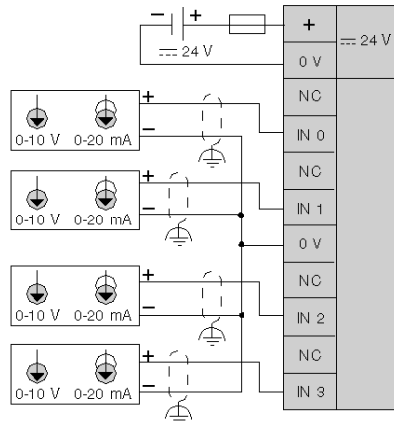

Connect an appropriate fuse for the applied voltage and current draw, at the position shown in the diagram.

** WARNING**

**UNINTENDED EQUIPMENT OPERATION**

- Use shielded cables wherever specified for inputs, outputs and communication connections.
- Properly ground the cable shields as indicated in the related documentation.
- Route communication and I/O cables separately from power cables.

**Failure to follow these instructions can result in death, serious injury, or equipment damage.**

** WARNING**

**UNINTENDED EQUIPMENT OPERATION**

Do not connect wires to unused terminals or terminals marked “Not Connected (N.C.)”.

**Failure to follow these instructions can result in death, serious injury, or equipment damage.**

**NOTE:** To help avoid interference of the analog signals, the power supply of the module must be turned on or off at the same time than the base controller power supply.

** WARNING**

**UNINTENDED EQUIPMENT OPERATION**

Turn the power supplies for the module and the associated controller on and off at the same time.

**Failure to follow these instructions can result in death, serious injury, or equipment damage.**



---

# TM2AMI8HT Analog Input Module

# 6

---

## Overview

This chapter describes the **TM2AMI8HT** module, its characteristics and its connection to the different sensors.

## What's in this Chapter?

This chapter contains the following topics:

Topic	Page
Presentation of the TM2AMI8HT Module	54
Characteristics of the TM2AMI8HT Module	55
Connecting the TM2AMI8HT Module	58

## Presentation of the TM2AMI8HT Module

### Main Specifications

<b>TM2 AMI8HT Main Specifications</b>		
Number of input channels	8	
Signal type	Voltage	Current
Input range	0...10 Vdc (non differential)	0....20 mA (non differential)
Resolution	10 bits (1024 points)	
Connection type	Removable screw terminal block	

## Characteristics of the TM2AMI8HT Module

### Introduction

This section provides a description of the electrical and the input characteristics of the **TM2AMI8HT** module.

### **⚠ DANGER**

#### **FIRE HAZARD**

Use only the recommended wire sizes for I/O channels and power supplies.

**Failure to follow these instructions will result in death or serious injury.**

### **⚠ WARNING**

#### **UNINTENDED EQUIPMENT OPERATION**

Do not exceed any of the rated values specified in the following tables.

**Failure to follow these instructions can result in death, serious injury, or equipment damage.**

### Dimensions

The following diagrams show the dimensions for the TM2AMI8HT analog I/O module.

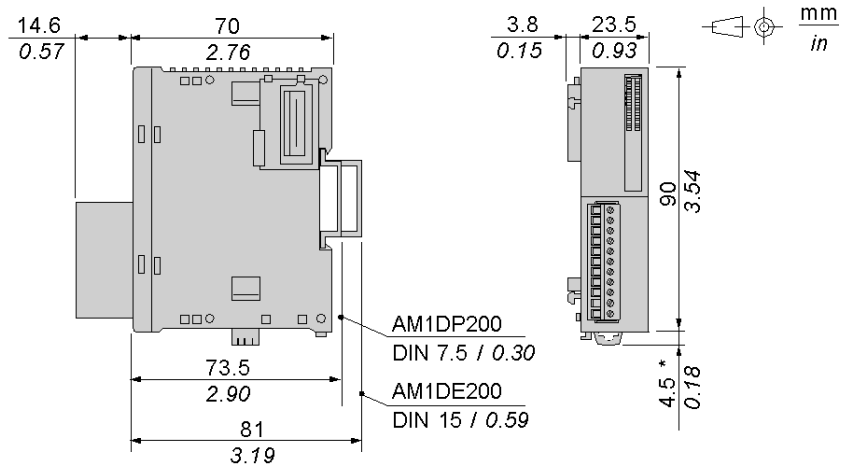

**NOTE:** \* 8.5 mm (0.33 in) when the clip-on lock is pulled out.

### General Characteristics

The following table shows the general characteristics of the **TM2AMI8HT** module:

Characteristic	Specification
Rated power supply voltage	24 Vdc
Power supply range	19.2...30 Vdc including ripple
Connector insertion/removal durability	100 times minimum
Internal 5 Vdc current draw	60 mA
Internal 24 Vdc current draw	0 mA
External 24 Vdc current draw	45 mA
Weight	85 g (3 oz)

### Inputs Characteristics

The following table shows the inputs characteristics of the **TM2AMI8HT** module:

Characteristic	Voltage input	Current input
Input range	0...10 Vdc	0...20 mA DC
Input impedance	10 K $\Omega$ min.	< 250 $\Omega$
Sample duration time	160 ms	
Total input system transfer time	8 x 160 ms + 1 scan time	
Input type	Non differential	
Operating mode	Self-scan	
Conversion mode	$\Sigma\Delta$ type ADC	
Input error - maximum error at 25° C (77° F)	$\pm 0.2$ % of full scale	
Input tolerance - temperature drift	$\pm 0.5$ % of full scale/ $^{\circ}$ C	
Input tolerance - repeatable after stabilization time	$\pm 0.4$ % of full scale	
Input tolerance - nonlinear	$\pm 0.002$ % of full scale	
Input tolerance - maximum deviation	1 % of full scale	
Digital resolution	1024 increments (10 bits)	
Input value of LSB	9.7 mV	19.5 $\mu$ A
Data type in application program	0 to 1023 (10 bit) Custom range up to -32768 to 32767	
Input data out of range detection	Yes <sup>1</sup>	

Characteristic	Voltage input	Current input
Noise resistance - maximum temporary deviation during perturbations	±1 % of full scale	
Noise resistance - cable	Twisted-pair shielded cable is necessary	
Noise resistance - crosstalk	1 LSB maximum	
Isolation between inputs and power supply	None	
Isolation between inputs	None	
Isolation between power supply, inputs and internal logic circuits	2500 Vac by photocoupler	
Maximum continuous allowed overload (no damage)	13 Vdc	40 mA
Calibration or verification to maintain rated accuracy	Approximately 10 years	

**NOTE:**

1. Total input system transfer time = sample repetition x 2 + 1 scan time.
2. The 10-bit data (0 to 4095) processed in the Analog I/O module can be linear-converted to a value between -32768 and 32767. The optional range designation and analog I/O data minimum and maximum values can be selected using data registers allocated to analog I/O modules.
3. When an input error is detected, a corresponding error code is stored to a data register allocated to analog I/O operating status.

## Connecting the TM2AMI8HT Module

### Wiring Rules

See Wiring Rules and Recommendations (*see page 26*).

### TM2AMI8HT Wiring Diagram

The following diagram shows the connection of the module inputs.

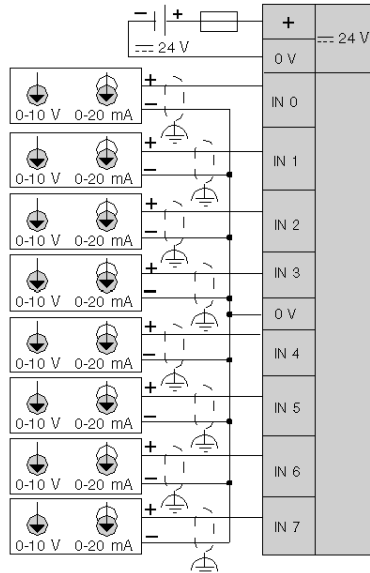

Connect an appropriate fuse for the applied voltage and current draw, at the position shown in the diagram.

## **⚠ WARNING**

### **UNINTENDED EQUIPMENT OPERATION**

- Use shielded cables wherever specified for inputs, outputs and communication connections.
- Properly ground the cable shields as indicated in the related documentation.
- Route communication and I/O cables separately from power cables.

**Failure to follow these instructions can result in death, serious injury, or equipment damage.**

** WARNING**

**UNINTENDED EQUIPMENT OPERATION**

Do not connect wires to unused terminals or terminals marked “Not Connected (N.C.)”.

**Failure to follow these instructions can result in death, serious injury, or equipment damage.**

**NOTE:** To help avoid interference of the analog signals, the power supply of the module must be turned on or off at the same time than the base controller power supply.

** WARNING**

**UNINTENDED EQUIPMENT OPERATION**

Turn the power supplies for the module and the associated controller on and off at the same time.

**Failure to follow these instructions can result in death, serious injury, or equipment damage.**



---

# TM2ARI8HT Analog Input Module



---

## Overview

This chapter describes the **TM2ARI8HT** module, its characteristics and its connection to the different sensors.

## What's in this Chapter?

This chapter contains the following topics:

Topic	Page
Presentation of the TM2ARI8HT Module	62
Characteristics of the TM2ARI8HT Module	63
Connecting the TM2ARI8HT Module	66

## Presentation of the TM2ARI8HT Module

### Main Specifications

<b>TM2ARI8HT Main Specifications</b>	
Number of input channels	8
Signal type	Temperature
Input range	NTC/PTC, $100 \Omega < R < 10 \text{ k}\Omega$
Resolution	10 bits (1024 points)
Connection type	Removable screw terminal block

## Characteristics of the TM2ARI8HT Module

### Introduction

This section provides a description of the electrical and the input characteristics of the **TM2ARI8HT** module.

### DANGER

#### FIRE HAZARD

Use only the recommended wire sizes for I/O channels and power supplies.

**Failure to follow these instructions will result in death or serious injury.**

### WARNING

#### UNINTENDED EQUIPMENT OPERATION

Do not exceed any of the rated values specified in the following tables.

**Failure to follow these instructions can result in death, serious injury, or equipment damage.**

### Dimensions

The following diagrams show the dimensions for the TM2ARI8HT analog I/O module.

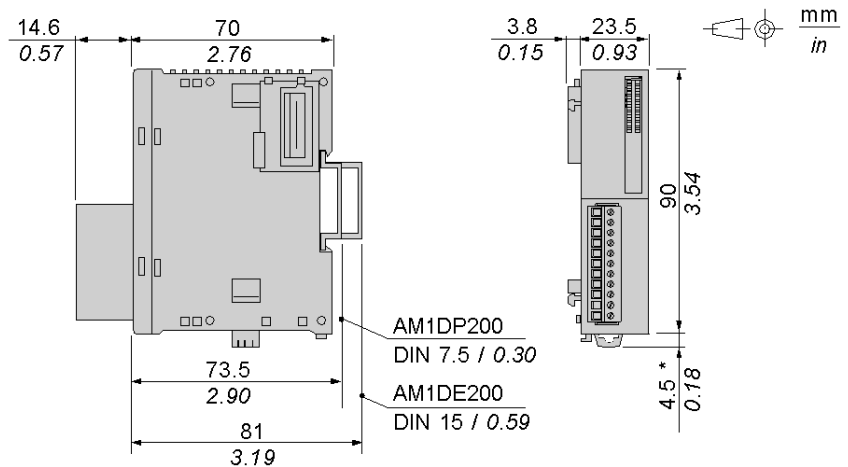

**NOTE:** \* 8.5 mm (0.33 in) when the clip-on lock is pulled out.

### General Characteristics

The following table shows the general characteristics of the **TM2ARI8HT** module:

Characteristic	Specification
Rated power supply voltage	24 Vdc
Power supply range	19.2...30 Vdc including ripple
Connector insertion/removal durability	100 times minimum
Internal 5 Vdc current draw	60 mA
Internal 24 Vdc current draw	0 mA
External 24 Vdc current draw	45 mA
Weight	85 g (3 oz)

### Inputs Characteristics

The following table shows the input characteristics of the **TM2ARI8HT** module:

Characteristic	Specification
Input range	NTC or PTC thermistor Resistance range: 100...1000 $\Omega$
Input impedance	1 M $\Omega$ min.
Sample duration time	160 ms
Total input system transfer time	8x160 ms + 1 scan time
Input type	Non differential input
Operating mode	Self-scan
Conversion mode	$\Sigma\Delta$ type ADC
Input tolerance - maximum deviation at 25°C (77°F)	$\pm 0.2$ % of full scale
Input tolerance - temperature drift	$\pm 0.01$ % of full scale/ $^{\circ}$ C
Input tolerance - repeatable after stabilization time	$\pm 0.4$ % of full scale
Input tolerance - nonlinear	$\pm 0.002$ % of full scale
Input tolerance - maximum deviation	$\pm 1$ % of full scale
Digital resolution	1024 increments (10 bits)
Input value of LSB	Depending on the probe
Data type in application program	0 to 1023 (10 bit data) Custom range up to -32768 to 32767
Input data out of range detection	Yes <sup>1</sup>
Noise resistance - maximum temporary deviation during perturbations	$\pm 1$ % of full scale

Characteristic	Specification
Noise resistance - cable	Twisted-pair shielded cable is necessary
Noise resistance - crosstalk	1 LSB maximum
Isolation between power supply and inputs	None
Isolation between inputs	None
Isolation between power supply, inputs and internal logic circuits	2500 Vac by photocoupler
Calibration or verification to maintain rated accuracy	Approximately 10 years

**NOTE:**

1. Total input system transfer time = sample repetition x 2 + 1 scan time.
2. The 10-bit data (0 to 4095) processed in the Analog I/O module can be linear-converted to a value between -32768 and 32767. The optional range designation and analog I/O data minimum and maximum values can be selected using data registers allocated to analog I/O modules.
3. When an input error is detected, a corresponding error code is stored to a data register allocated to analog I/O operating status.

## Connecting the TM2ARI8HT Module

### Wiring Rules

See Wiring Rules and Recommendations (*see page 26*).

### TM2ARI8HT Wiring Diagram

The following diagram shows the connection of the module inputs.

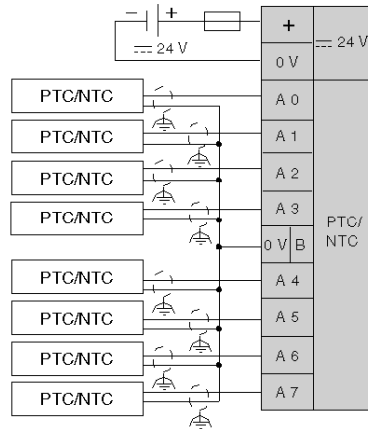

Connect an appropriate fuse for the applied voltage and current draw, at the position shown in the diagram.

## **⚠ WARNING**

### **UNINTENDED EQUIPMENT OPERATION**

- Use shielded cables wherever specified for inputs, outputs and communication connections.
- Properly ground the cable shields as indicated in the related documentation.
- Route communication and I/O cables separately from power cables.

**Failure to follow these instructions can result in death, serious injury, or equipment damage.**

** WARNING**

**UNINTENDED EQUIPMENT OPERATION**

Do not connect wires to unused terminals or terminals marked “Not Connected (N.C.)”.

**Failure to follow these instructions can result in death, serious injury, or equipment damage.**

**NOTE:** To help avoid interference of the analog signals, the power supply of the module must be turned on or off at the same time than the base controller power supply.

** WARNING**

**UNINTENDED EQUIPMENT OPERATION**

Turn the power supplies for the module and the associated controller on and off at the same time.

**Failure to follow these instructions can result in death, serious injury, or equipment damage.**



---

# TM2ARI8LRJ Analog Input Module

# 8

---

## Overview

This chapter describes the **TM2ARI8LRJ** module, its characteristics and its connection to the different sensors.

## What's in this Chapter?

This chapter contains the following topics:

Topic	Page
Presentation of the TM2ARI8LRJ Module	70
Characteristics of the TM2ARI8LRJ Module	71
Connecting the TM2ARI8LRJ Module	75

## Presentation of the TM2ARI8LRJ Module

### Main Specifications

<b>TM2ARI8LRJ Main Specifications</b>	
Number of input channels	8
Sensor type	Temperature probe
Input type	PT100 / PT1000
Resolution	12 bits (4096 points)
Connection type	8 x RJ11 connector

## Characteristics of the TM2ARI8LRJ Module

### Introduction

This section provides a description of the electrical and the input characteristics of the **TM2ARI8LRJ** module.

### **DANGER**

#### **FIRE HAZARD**

Use only the recommended wire sizes for I/O channels and power supplies.

**Failure to follow these instructions will result in death or serious injury.**

### **WARNING**

#### **UNINTENDED EQUIPMENT OPERATION**

Do not exceed any of the rated values specified in the following tables.

**Failure to follow these instructions can result in death, serious injury, or equipment damage.**

## Dimensions

The following diagrams show the dimensions for the TM2ARI8LRJ analog I/O module.

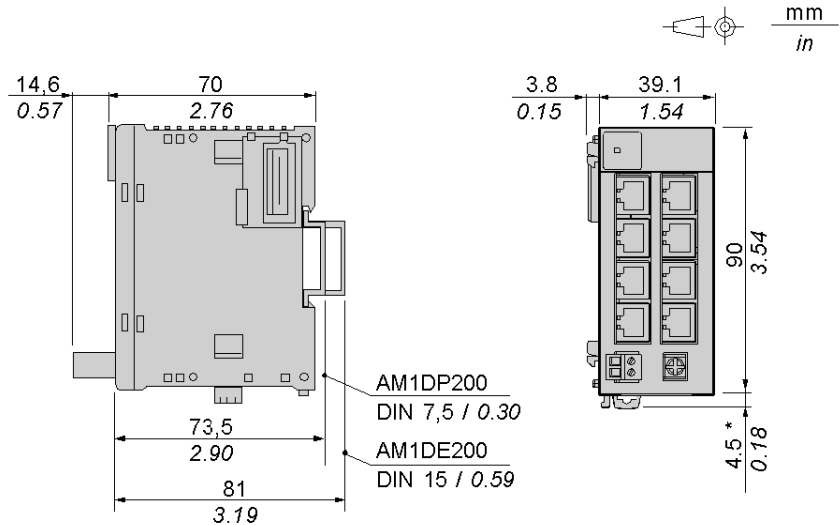

**NOTE:** \* 8.5 mm (0.33 in) when the clip-on lock is pulled out.

## General Characteristics

The following table shows the general characteristics of the **TM2ARI8LRJ** module:

Characteristic	Specification
Rated power supply voltage	24 Vdc
Power supply range	19.2...30 Vdc including ripple
RJ11 connector	50 times minimum
Power supply connector	50 times minimum
Connector insertion/removal durability	100 times minimum
Internal 5 Vdc current draw	90 mA
Internal 24 Vdc current draw	0 mA
External 24 Vdc current draw	140 mA
Weight	118 g (4.17 oz)

## Inputs Characteristics

The following table shows the input characteristics of the **TM2ARI8LRJ** module:

Characteristic	Specification
Input range	PT1000: -50...200 °C (-58...392 °F) PT100: -200...600 °C (-328...1112 °F)
Input impedance	> 10 kΩ
Sample duration time	320 ms per channel
Total input system transfer time	4 x 320 ms + 1 scan time
Input type	Non differential input
Operating mode	Self-scan
Conversion mode	ΣΔ type ADC
Input tolerance - maximum deviation at ambient 25 °C (77 °F)	PT1000: ± 0.5 °C ( 0.9 °F) PT100: ± 1.5 °C ( 2.7 °F) Range -50 °C (-58 °F) to 200 °C (392 °F): ±1 °C (33.8 °F) Range -200 °C (392 °F) to 600 °C (1112 °F): +0.1% / -0.5% full scale
Input tolerance- temperature drift	± 0.5 °C ( 0.9 °F)
Input deviation- repeatable after stabilization time	± 0.1 °C ( 32.18 °F)
Digital resolution	4096 increments (12 bits)
Input value of LSB	PT1000: ±1 °C ( 33.8 °F) PT100: +1 °C / -4 °C ( 33.8 °F / 24.8 °F)
Total maximum deviation	PT1000: 0.06 °C ( 0.108 °F) PT100: 0.2 °C ( 0.36 °F)
Data type in application program	0 to 4095 (12 bit data) Custom range up to -32768 to 32767
Input data out of range detection	Yes <sup>(1)</sup>
Broken wire detection	Yes <sup>(1)</sup>
Noise resistance - maximum temporary deviation during perturbations	±1 % of full scale
Cable resistance compensation	100 Ω max
Noise resistance - crosstalk	1 LSB maximum
Isolation between inputs	None
Isolation between inputs, power supply and internal logic circuits	2500 Vac by photocouplers
Isolation between inputs and external power supply	500 Vac

Characteristic	Specification
Dielectric strength	- 1500 Vrms between inputs and internal bus - 500 Vrms between inputs and 0V - 1500 Vrms between internal bus and 0V
Type of protection with terminal bus	Photocoupler between input and internal circuit: 1500 Vac isolation
Selection of analog input signal type	Using software programming <b>NOTE:</b> It is possible to use PT100 and PT1000's probe.
Default input value in case of temperature sensor disconnection	Upper limit

**NOTE:**

1. Total input system transfer time = sample repetition x 2 + 1 scan time.
2. The 10-bit data (0 to 4095) processed in the Analog I/O module can be linear-converted to a value between -32768 and 32767. The optional range designation and analog I/O data minimum and maximum values can be selected using data registers allocated to analog I/O modules.
3. When an input error is detected, a corresponding error code is stored to a data register allocated to analog I/O operating status.

## Connecting the TM2ARI8LRJ Module

### Wiring Rules

See Wiring Rules and Recommendations (*see page 26*).

### TM2ARI8LRJ Wiring Diagram

The following diagram shows the connection of the module inputs.

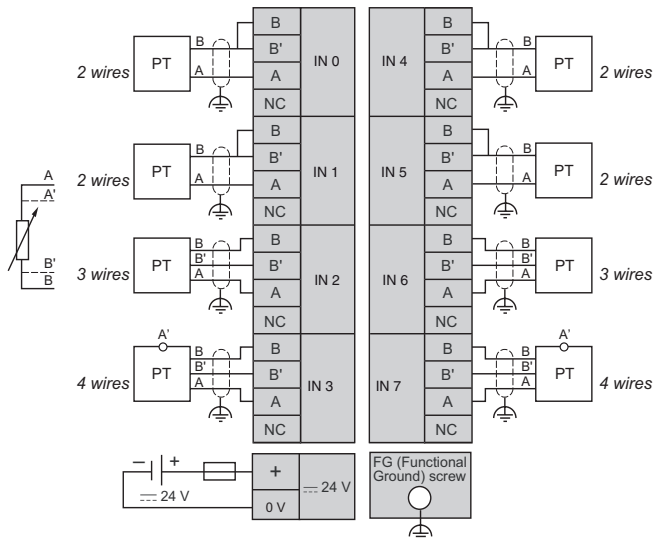
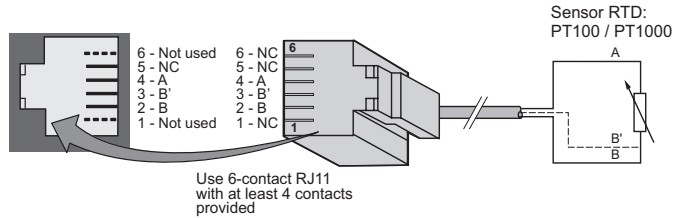

- Use RJ11 6 pins connectors with a minimum of 4 pins equipped.
- Connect an appropriate fuse for the applied voltage and current draw, at the position shown in the diagram.
- For functional ground screw, use a screw-driver with a diameter of 3.5 mm (0.14 in) and apply a torque of 0.5 N.m (4.4 lb-in).

## ⚠ WARNING

### UNINTENDED EQUIPMENT OPERATION

- Use shielded cables wherever specified for inputs, outputs and communication connections.
- Properly ground the cable shields as indicated in the related documentation.
- Route communication and I/O cables separately from power cables.

**Failure to follow these instructions can result in death, serious injury, or equipment damage.**

## ⚠ WARNING



### UNINTENDED EQUIPMENT OPERATION

Do not connect wires to unused terminals or terminals marked “Not Connected (N.C.)”.

**Failure to follow these instructions can result in death, serious injury, or equipment damage.**

The following table shows the characteristics of the functional ground connection:



 Ø 3,5 mm (0.14 in)		N.m	0,5
		<i>lb-in</i>	4.4

---

# TM2ARI8LT Analog Input Module

# 9

---

## Overview

This chapter describes the **TM2ARI8LT** module, its characteristics and its connection to the different sensors.

## What's in this Chapter?

This chapter contains the following topics:

Topic	Page
Presentation of the TM2ARI8LT Module	78
Characteristics of the TM2ARI8LT Module	79
Connecting the TM2ARI8LT Module	83

## Presentation of the TM2ARI8LT Module

### Main Specifications

<b>TM2ARI8LT Main Specifications</b>	
Number of input channels	8
Sensor type	Temperature probe
Input type	PT100 / PT1000
Resolution	12 bits (4096 points)
Connection type	2 x Removable screw terminal block

## Characteristics of the TM2ARI8LT Module

### Introduction

This section provides a description of the electrical and the input characteristics of the **TM2ARI8LT** module.

### **DANGER**

#### **FIRE HAZARD**

Use only the recommended wire sizes for I/O channels and power supplies.

**Failure to follow these instructions will result in death or serious injury.**

### **WARNING**

#### **UNINTENDED EQUIPMENT OPERATION**

Do not exceed any of the rated values specified in the following tables.

**Failure to follow these instructions can result in death, serious injury, or equipment damage.**

## Dimensions

The following diagrams show the dimensions for the TM2ARI8LT analog I/O module.

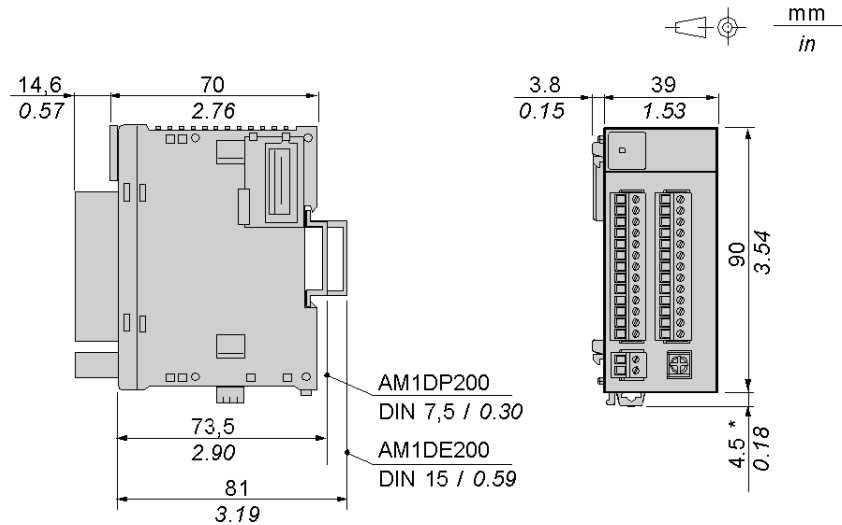

**NOTE:** \* 8.5 mm (0.33 in) when the clip-on lock is pulled out.

## General Characteristics

The following table shows the general characteristics of the **TM2ARI8LT** module:

Characteristic	Specification
Rated power supply voltage	24 Vdc
Power supply range	19.2...30 Vdc including ripple
Connector insertion/removal durability	100 times minimum
Internal 5 Vdc current draw	90 mA
Internal 24 Vdc current draw	0 mA
External 24 Vdc current draw	140 mA
Weight	147 g (8.06 oz)

## Inputs Characteristics

The following table shows the input characteristics of the **TM2ARI8LT** module:

Characteristic	Specification
Input range	PT1000: -50...200°C (-58...392°F) PT100: -200...600°C (-328...1112°F)
Input impedance	> 10 kΩ
Sample duration time	320 ms per channel
Total input system transfer time	4 x 320 ms + 1 scan time
Input type	Differential input
Operating mode	Self-scan
Conversion mode	ΣΔ type ADC
Input tolerance - maximum deviation at ambient ± 25°C (77°F)	PT1000: ± 0.5 °C (0.9 °F) PT100: ± 1.5 °C (2.7 °F) Range -50 °C (-58 °F) to 200°C(392°F): ±1°C(±33.8 °F) Range -200 °C (392 °F) to 600 °C (1112 °F): +0.1% / -0.5% full scale
Input tolerance- temperature drift	± 0.5 °C (0.9 °F)
Input deviation - repeatable after stabilization time	±0.1 °C (±32.18 °F)
Digital resolution	4096 increments (12 bits)
Input value of LSB	PT1000: 0.06°C (0.108 °F) PT100: 0.2°C (0.36 °F)
Total maximum deviation	PT 1000: ±1 °C (±33.8 °F) PT100: +1 °C (33.8 °F) / -4 °C (24.8 °F)
Data type in application program	0 to 4095 (12 bit data) Custom range up to -32768 to 32767
Input data out of range detection	Yes <sup>(1)</sup>
Broken wire detection	Yes <sup>(1)</sup>
Noise resistance - maximum temporary deviation during perturbations	±1 % of full scale
Cable resistance compensation	100 Ω max
Noise resistance - crosstalk	1 LSB maximum
Isolation between inputs	None
Isolation between inputs and external power supply	500 Vac
Isolation between inputs, power supply and internal logic circuits	2500 Vac by photocouplers

Characteristic	Specification
Dielectric strength	- 1500 Vrms between inputs and internal bus - 500 Vrms between inputs and 0V - 1500 Vrms between internal bus and 0V
Type of protection with terminal bus	Photocoupler between input and internal circuit: 1500 Vac isolation
Selection of analog input signal type	Using software programming <b>NOTE:</b> It is possible to use PT100 and PT 1000's probe.
Default input value in case of temperature sensor disconnection	Upper limit

**NOTE:**

1. Total input system transfer time = sample repetition x 2 + 1 scan time.
2. The 10-bit data (0 to 4095) processed in the Analog I/O module can be linear-converted to a value between -32768 and 32767. The optional range designation and analog I/O data minimum and maximum values can be selected using data registers allocated to analog I/O modules.
3. When an input error is detected, a corresponding error code is stored to a data register allocated to analog I/O operating status.

## Connecting the TM2ARI8LT Module

### Wiring Rules

See Wiring Rules and Recommendations (*see page 26*).

### TM2ARI8LT Wiring Diagram

The following diagram shows the connection of the module inputs.

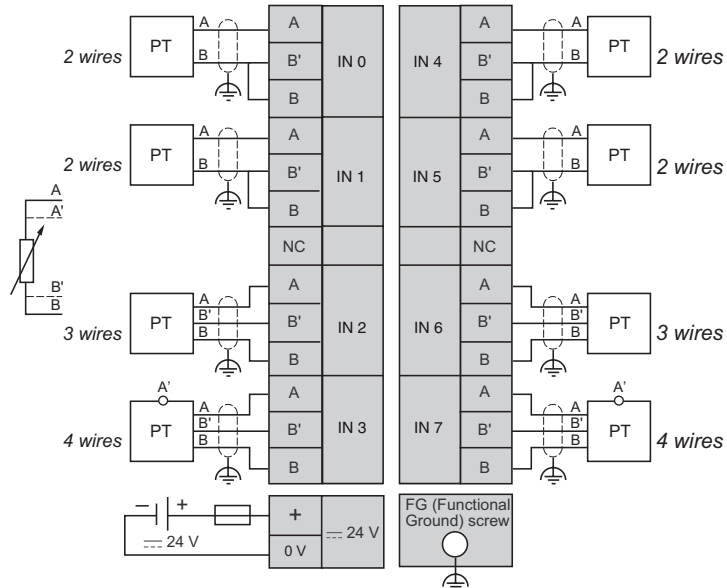

- Connect an appropriate fuse for the applied voltage and current draw, at the position shown in the diagram.
- Do not connect any wiring to unused channels.

## **⚠ WARNING**

### **UNINTENDED EQUIPMENT OPERATION**

- Use shielded cables wherever specified for inputs, outputs and communication connections.
- Properly ground the cable shields as indicated in the related documentation.
- Route communication and I/O cables separately from power cables.

**Failure to follow these instructions can result in death, serious injury, or equipment damage.**

## ⚠ WARNING



### UNINTENDED EQUIPMENT OPERATION

Do not connect wires to unused terminals or terminals marked “Not Connected (N.C.)”.

**Failure to follow these instructions can result in death, serious injury, or equipment damage.**

The following table shows the connection of the functional ground screw:



 Ø 3,5 mm (0.14 in)		N.m	0,5
		<i>lb-in</i>	<i>4.4</i>

---

# TM2AMO1HT Analog Output Module

# 10

---

## Overview

This chapter describes the **TM2AMO1HT** module, its characteristics and its connection to the different sensors.

## What's in this Chapter?

This chapter contains the following topics:

Topic	Page
Presentation of the TM2AMO1HT Module	86
Characteristics of the TM2AMO1HT Module	87
Connecting the TM2AMO1HT Module	90

## Presentation of the TM2AMO1HT Module

### Main Specifications

<b>TM2AMO1HT Main Specifications</b>		
Number of output channels	1	
Signal type	Voltage	Current
Output range	0...10 Vdc	4....20 mA
Resolution	12 bits (4096 points)	
Connection type	Removable screw terminal block	

## Characteristics of the TM2AMO1HT Module

### Introduction

This section provides a description of the electrical and the output characteristics of the **TM2AMO1HT** module.

### **⚠ DANGER**

#### **FIRE HAZARD**

Use only the recommended wire sizes for I/O channels and power supplies.

**Failure to follow these instructions will result in death or serious injury.**

### **⚠ WARNING**

#### **UNINTENDED EQUIPMENT OPERATION**

Do not exceed any of the rated values specified in the following tables.

**Failure to follow these instructions can result in death, serious injury, or equipment damage.**

### Dimensions

The following diagrams show the dimensions for the TM2AMO1HT analog I/O module.

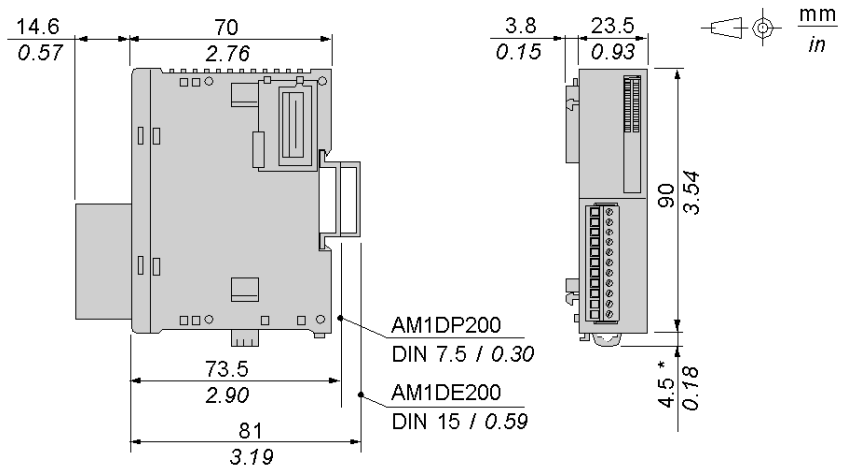

**NOTE:** \* 8.5 mm (0.33 in) when the clip-on lock is pulled out.

### General Characteristics

The following table shows the general characteristics of the **TM2AMO1HT** module:

Characteristic	Specification
Rated power supply voltage	24 Vdc
Power supply range	19.2...30 Vdc including ripple
Connector insertion/removal durability	100 times minimum
Internal 5 Vdc current draw	50 mA
Internal 24 Vdc current draw	0 mA)
External 24 Vdc current draw	40 mA
Weight	85 g (3 oz)

### Outputs Characteristics

The following table shows the outputs characteristics of the **TM2AMO1HT** module:

Characteristic	Voltage output	Current output
Output range	0...10 Vdc	4...20 mA
Load impedance	2 k $\Omega$ minimum	300 $\Omega$ maximum
Application load type	Resistive load	
Settling time	10 ms	
Total output system transfer Time	10 ms + 1 scan time	
Output tolerance - maximum deviation at 25°C (77°F)	$\pm 0.2\%$ of full scale	
Output tolerance - temperature drift	$\pm 0.015\%$ of full scale/ $^{\circ}$ C	
Output tolerance - repeatable after stabilization time	$\pm 0.5\%$ of full scale	
Output tolerance - output voltage drop	$\pm 1\%$ of full scale	
Output tolerance - nonlinear	$\pm 0.2\%$ of full scale	
Output tolerance - output ripple	1 LSB maximum	
Output tolerance - overshoot	0%	
Output tolerance - total deviation	$\pm 1\%$ of full scale	
Digital resolution	4096 increments (12 bits)	
Output value of LSB	2.5 mV	4.8 $\mu$ A

Characteristic	Voltage output	Current output
Data type in application program	0 to 4095 (12 bit data) Custom range up to -32768 to 32767 <sup>1</sup>	
External power supply connection	Detected <sup>2</sup>	Detected <sup>2</sup>
Noise resistance - cable	Twisted-pair shielded cable is necessary	
Isolation between output and external power supply	500 Vac	
Isolation between output and power supply	500 Vac	
Isolation between output, external power supply and internal logic circuits	500 Vac by photocoupler	
Selection of analog output signal type	Using software programming	
Calibration or verification to maintain rated accuracy	Approximately 10 years	

**NOTE:**

1. The 12-bit data (0 to 4095) processed in the Analog I/O module can be linear-converted to a value between -32768 and 32767. The optional range designation and analog I/O data minimum and maximum values can be selected using data registers allocated to analog I/O modules.
2. When the external 24 Vdc is not connected, a corresponding error code is stored to a data register allocated to analog I/O operating status.

## Connecting the TM2AMO1HT Module

### Wiring Rules

See Wiring Rules and Recommendations (*see page 26*).

### TM2AMO1HT Wiring Diagram

The following diagram shows the connection of the output module.

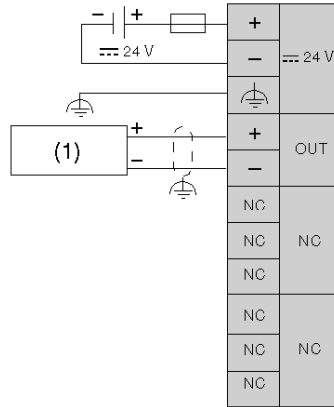

(1) Voltage/current preactuator

To use the braid supplied with the module to connect the functional ground.

Connect an appropriate fuse for the applied voltage and current draw, at the position shown in the diagram.

## **⚠ WARNING**

### **UNINTENDED EQUIPMENT OPERATION**

- Use shielded cables wherever specified for inputs, outputs and communication connections.
- Properly ground the cable shields as indicated in the related documentation.
- Route communication and I/O cables separately from power cables.

**Failure to follow these instructions can result in death, serious injury, or equipment damage.**

** WARNING**

**UNINTENDED EQUIPMENT OPERATION**

Do not connect wires to unused terminals or terminals marked “Not Connected (N.C.)”.

**Failure to follow these instructions can result in death, serious injury, or equipment damage.**

**NOTE:** To help avoid interference of the analog signals, the power supply of the module must be turned on or off at the same time than the base controller power supply.

** WARNING**

**UNINTENDED EQUIPMENT OPERATION**

Turn the power supplies for the module and the associated controller on and off at the same time.

**Failure to follow these instructions can result in death, serious injury, or equipment damage.**



---

# TM2AVO2HT Analog Output Module

# 11

---

## Overview

This chapter describes the **TM2AVO2HT** module, its characteristics and its connection to the different sensors.

## What's in this Chapter?

This chapter contains the following topics:

Topic	Page
Presentation of the TM2AVO2HT Module	94
Characteristics of the TM2AVO2HT Module	95
Connecting the TM2AVO2HT Module	98

## Presentation of the TM2AVO2HT Module

### Main Specifications

<b>TM2AVO2HT Main Specifications</b>	
Number of output channels	2
Signal type	Voltage
Output range	$\pm 10$ Vdc
Resolution	11 bits + sign
Connection type	Removable screw terminal block

## Characteristics of the TM2AVO2HT Module

### Introduction

This section provides a description of the electrical and the output characteristics of the **TM2AVO2HT** module.

### DANGER

#### FIRE HAZARD

Use only the recommended wire sizes for I/O channels and power supplies.

**Failure to follow these instructions will result in death or serious injury.**

### WARNING

#### UNINTENDED EQUIPMENT OPERATION

Do not exceed any of the rated values specified in the following tables.

**Failure to follow these instructions can result in death, serious injury, or equipment damage.**

### Dimensions

The following diagrams show the dimensions for the TM2AVO2HT analog I/O module.

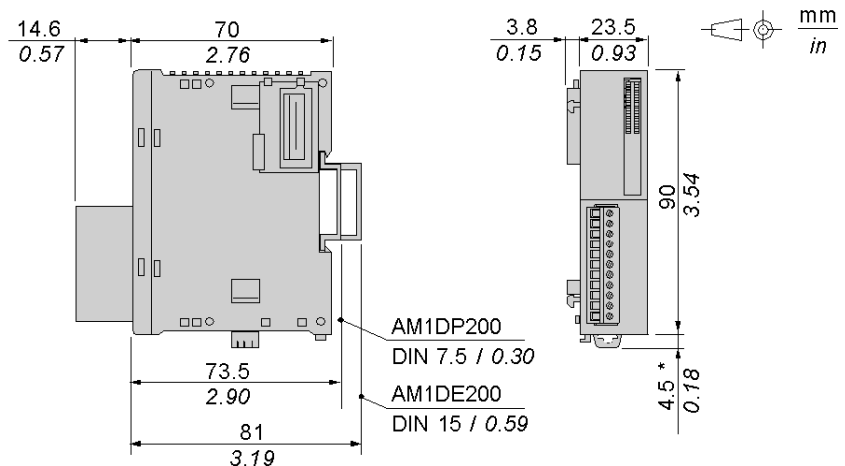

**NOTE:** \* 8.5 mm (0.33 in) when the clip-on lock is pulled out.

### General Characteristics

The following table shows the general characteristics of the **TM2AVO2HT** module:

Characteristic	Specification
Rated power supply voltage	24 Vdc
Power supply range	19.2...30 Vdc including ripple
Connector insertion/removal durability	100 times minimum
Internal 5 Vdc current draw	60 mA
Internal 24 Vdc current draw	0 mA
External 24 Vdc current draw	60 mA
Weight	85 g (3 oz)

### Outputs Characteristics

The following table shows the outputs characteristics of the **TM2AVO2HT** module:

Characteristic	Voltage output
Output range	$\pm 10$ Vdc
Load impedance	3 k $\Omega$ min
Application load type	Resistive load
Settling time	2 ms
Total output system transfer Time	2 ms + 1 scan time
Output tolerance - maximum deviation at 25° C (77°F)	$\pm 0.5\%$ of full scale
Output tolerance - temperature drift	$\pm 0.01\%$ of full scale/° C
Output tolerance - repeatable after stabilization time	$\pm 0.1\%$ of full scale
Output tolerance - output voltage drop	$\pm 0.5\%$ of full scale
Output tolerance - nonlinear	$\pm 0.2\%$ of full scale
Output tolerance - output ripple	1 LSB maximum
Output tolerance - overshoot	0%
Output tolerance - total deviation	$\pm 1\%$ of full scale
Digital resolution	11 bits + sign
Output value of LSB	$\pm 9.8$ mV
Data type in application program	-2,048 to 2,047 <sup>1</sup> Custom range up to -32768 to 32767
Current loop open	Not detectable
Noise resistance - maximum temporary deviation during perturbations	$\pm 1\%$ of full scale

Characteristic	Voltage output
Noise resistance - cable	Twisted-pair shielded cable is necessary
Isolation between outputs	None
Isolation between outputs and external power supply	None
Isolation between outputs, external power supply and internal logic circuits	2500 Vac by photocoupler
Selection of analog output signal type	Using software programming
Calibration or verification to maintain rated accuracy	Approximately 10 years

**NOTE:**

1. The 12-bit data (0 to 4095) processed in the Analog I/O module can be linear-converted to a value between -32768 and 32767. The optional range designation and analog I/O data minimum and maximum values can be selected using data registers allocated to analog I/O modules.

## Connecting the TM2AVO2HT Module

### Wiring Rules

See Wiring Rules and Recommendations (*see page 26*).

### TM2AVO2HT Wiring Diagram

The following diagram shows the connection of the module outputs.

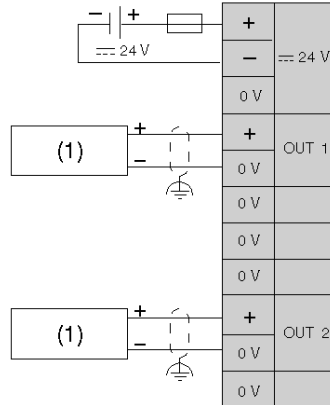

(1) Voltage/current preactuator

To use the braid supplied with the module to connect the functional ground.

Connect an appropriate fuse for the applied voltage and current draw, at the position shown in the diagram.

## **⚠ WARNING**

### **UNINTENDED EQUIPMENT OPERATION**

- Use shielded cables wherever specified for inputs, outputs and communication connections.
- Properly ground the cable shields as indicated in the related documentation.
- Route communication and I/O cables separately from power cables.

**Failure to follow these instructions can result in death, serious injury, or equipment damage.**

** WARNING**

**UNINTENDED EQUIPMENT OPERATION**

Do not connect wires to unused terminals or terminals marked “Not Connected (N.C.)”.

**Failure to follow these instructions can result in death, serious injury, or equipment damage.**

**NOTE:** To help avoid interference of the analog signals, the power supply of the module must be turned on or off at the same time than the base controller power supply.

** WARNING**

**UNINTENDED EQUIPMENT OPERATION**

Turn the power supplies for the module and the associated controller on and off at the same time.

**Failure to follow these instructions can result in death, serious injury, or equipment damage.**



---

# TM2AMM3HT Analog Mixed I/O Module

# 12

---

## Overview

This chapter describes the **TM2AMM3HT** module, its characteristics and its connection to the different sensors.

## What's in this Chapter?

This chapter contains the following topics:

Topic	Page
Presentation of the TM2AMM3HT Module	102
Characteristics of the TM2AMM3HT Module	103
Connecting the TM2AMM3HT Module	107

## Presentation of the TM2AMM3HT Module

### Main Specifications

<b>TM2AMM3HT Main Specifications</b>				
Number of I/O channels	2 Inputs		1 Output	
Signal type	Voltage	Current	Voltage	Current
Range	0...10 Vdc (non differential)	4...20 mA (non differential)	0...10 Vdc	4...20 mA
Resolution	12 bits (4096 points)			
Connection type	Removable screw terminal block			

## Characteristics of the TM2AMM3HT Module

### Introduction

This section provides a description of the electrical and the I/O characteristics of the **TM2AMM3HT** module.

### **⚠ DANGER**

#### **FIRE HAZARD**

Use only the recommended wire sizes for I/O channels and power supplies.

**Failure to follow these instructions will result in death or serious injury.**

### **⚠ WARNING**

#### **UNINTENDED EQUIPMENT OPERATION**

Do not exceed any of the rated values specified in the following tables.

**Failure to follow these instructions can result in death, serious injury, or equipment damage.**

### Dimensions

The following diagrams show the dimensions for the TM2AMM3HT analog I/O module.

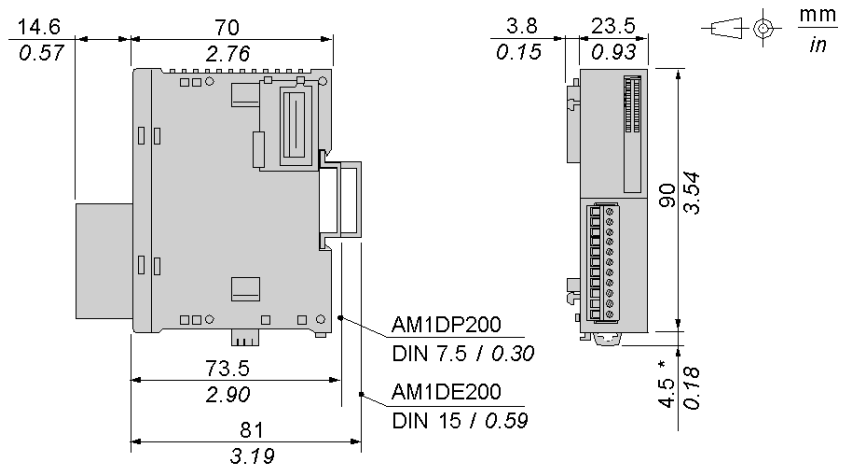

**NOTE:** \* 8.5 mm (0.33 in) when the clip-on lock is pulled out.

### General Characteristics

The following table shows the general characteristics of the **TM2AMM3HT** module:

Characteristic	Specification
Rated power supply voltage	24 Vdc
Power supply range	19.2 ... 30 Vdc including ripple
Connector insertion/removal durability	100 times minimum
Internal 5 Vdc current draw	50 mA
Internal 24 Vdc current draw	0 mA
External 24 Vdc current draw	50 mA
Weight	85 g (3 oz)

### Inputs Characteristics

The following table shows the inputs characteristics of the **TM2AMM3HT** module:

Characteristic	Voltage input	Current input
Input range	0...10 Vdc	4...20 mA
Input impedance	1 M $\Omega$ min.	10 $\Omega$
Sample duration time	10 ms max.	
Total input system transfer time	60 ms + 1 scan time	
Input type	Non differential	
Operating mode	Self-scan	
Conversion mode	$\Sigma\Delta$ type ADC	
Input tolerance - maximum deviation at 25° C (77° F)	$\pm 0.2$ % of full scale	
Input tolerance - temperature drift	$\pm 0.006$ % of full scale/° C	
Input deviation - repeatable after stabilization time	$\pm 0.5$ % of full scale	
Input tolerance - nonlinear	$\pm 0.2$ % of full scale	
Input tolerance - maximum deviation	$\pm 1$ % of full scale	
Digital resolution	4096 increments (12 bits)	
Input value of LSB	2.5 mV	4.8 $\mu$ A
Data type in application program	0 to 4095 (12 bit data) Custom range up to -32768 to 32767 <sup>1</sup>	
Input data out of range detection	Yes <sup>2</sup>	

Characteristic	Voltage input	Current input
Noise resistance - maximum temporary deviation during perturbations	±1 % of full scale when a 500 Vdc clamp voltage is applied to the power and I/O wiring	
Noise resistance - cable	Twisted-pair shielded cable is necessary	
Noise resistance - crosstalk	2 LSB maximum	
Isolation between inputs	None	
Isolation between inputs and power supply	500 Vac	
Isolation between inputs, external power supply and internal logic circuits	500 Vac by photocoupler	
Maximum continuous allowed overload (no damage)	13 Vdc	40 mA
Selection of analog input signal type	Using software programming. It is possible to use current and voltage types.	
Calibration or verification to maintain rated accuracy	Approximately 10 years	

**NOTE:**

1. The 12-bit data (0 to 4095) processed in the Analog I/O module can be linear-converted to a value between -32768 and 32767. The optional range designation and analog I/O data minimum and maximum values can be selected using data registers allocated to analog I/O modules.
2. When an input error is detected, a corresponding error code is stored to a data register allocated to analog I/O operating status.

**Outputs Characteristics**

The following table shows the outputs characteristics of the **TM2AMM3HT** module:

Characteristic	Voltage output	Current output
Output range	0...10 Vdc	4...20 mA
Load impedance	2 kΩ minimum	300 Ω maximum
Application load type	Resistive load	
Settling time	10 ms	
Total output system transfer Time	10 ms + 1 scan time	
Output tolerance - maximum deviation at 25° C (77° F)	±0.2 % of full scale	

Characteristic	Voltage output	Current output
Output tolerance-temperature drift	$\pm 0.015$ % of full scale/ $^{\circ}$ C	
Output tolerance - repeatable after stabilization time	$\pm 0.5$ % of full scale	
Output tolerance - output voltage drop	$\pm 1$ % of full scale	
Output tolerance - nonlinear	$\pm 0.2$ % of full scale	
Output tolerance - output ripple	1 LSB maximum	
Output tolerance - overshoot	0%	
Output tolerance - total error	$\pm 1$ % of full scale	
Digital resolution	4096 increments (12 bits)	
Output value of LSB	2.5 mV	4.8 $\mu$ A
Data type in application program	0 to 4095 (12 bit data) Custom range up to -32768 to 32767 <sup>1</sup>	
External power supply connection	Detected <sup>2</sup>	Detected <sup>2</sup>
Noise resistance - maximum temporary deviation during perturbations	1% of full scale	
Noise resistance - cable	Twisted-pair shielded cable is necessary for improved noise immunity	
Isolation between output and external power supply	500 Vac	
Isolation between output, external power supply and internal logic circuits	500 Vac by photocoupler	
Selection of analog output signal type	Using software programming	
Calibration or verification to maintain rated accuracy	Approximately 10 years	

**NOTE:**

1. The 12-bit data (0 to 4095) processed in the Analog I/O module can be linear-converted to a value between -32768 and 32767. The optional range designation and analog I/O data minimum and maximum values can be selected using data registers allocated to analog I/O modules.
2. When the external 24 Vdc is not connected, a corresponding error code is stored to a data register allocated to analog I/O operating status.

## Connecting the TM2AMM3HT Module

### Wiring Rules

See Wiring Rules and Recommendations (*see page 26*).

### TM2AMM3HT Wiring Diagram

The following diagram shows the connection of the module I/O.

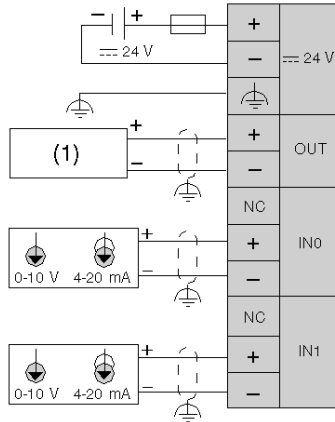

#### (1) Voltage/current preactuator

To use the braid supplied with the module to connect the functional ground.

Connect an appropriate fuse for the applied voltage and current draw, at the position shown in the diagram.

**NOTE:** The (-) poles of inputs IN0 and IN1 are connected internally.

## **⚠ WARNING**

### **UNINTENDED EQUIPMENT OPERATION**

- Use shielded cables wherever specified for inputs, outputs and communication connections.
- Properly ground the cable shields as indicated in the related documentation.
- Route communication and I/O cables separately from power cables.

**Failure to follow these instructions can result in death, serious injury, or equipment damage.**

** WARNING**

**UNINTENDED EQUIPMENT OPERATION**

Do not connect wires to unused terminals or terminals marked “Not Connected (N.C.)”.

**Failure to follow these instructions can result in death, serious injury, or equipment damage.**

**NOTE:** To help avoid interference of the analog signals, the power supply of the module must be turned on or off at the same time than the base controller power supply.

** WARNING**

**UNINTENDED EQUIPMENT OPERATION**

Turn the power supplies for the module and the associated controller on and off at the same time.

**Failure to follow these instructions can result in death, serious injury, or equipment damage.**

---

# TM2AMM6HT Analog Mixed I/O Module

13

---

## Overview

This chapter describes the **TM2AMM6HT** module, its characteristics and its connection to the different sensors.

## What's in this Chapter?

This chapter contains the following topics:

Topic	Page
Presentation of the TM2AMM6HT Module	110
Characteristics of the TM2AMM6HT Module	111
Connecting the TM2AMM6HT Module	116

## Presentation of the TM2AMM6HT Module

### Main Specifications

<b>TM2AMM6HT Main Specifications</b>				
Number of I/O channels	4 Inputs		2 Outputs	
Signal type	Voltage	Current	Voltage	Current
Range	0...10 Vdc (non differential)	4...20 mA (non differential)	0...10 Vdc	4...20 mA
Resolution	12 bits (4096 points)			
Connection type	Removable screw terminal block			

## Characteristics of the TM2AMM6HT Module

### Introduction

This section provides a description of the electrical and the I/O characteristics of the **TM2AMM6HT** module.

### **⚠ DANGER**

#### **CURRENT OVERLOAD AND FIRE POTENTIAL**

Select and install the appropriate wire size for the electrical current ratings of the I/O channels.

**Failure to follow these instructions will result in death or serious injury.**

### **⚠ WARNING**

#### **UNINTENDED EQUIPMENT OPERATION & EQUIPMENT DAMAGE**

Do not exceed any of the rated values specified below.

**Failure to follow these instructions can result in death, serious injury, or equipment damage.**

### Dimensions

The following diagrams show the dimensions for the TM2AMM6HT analog I/O module.

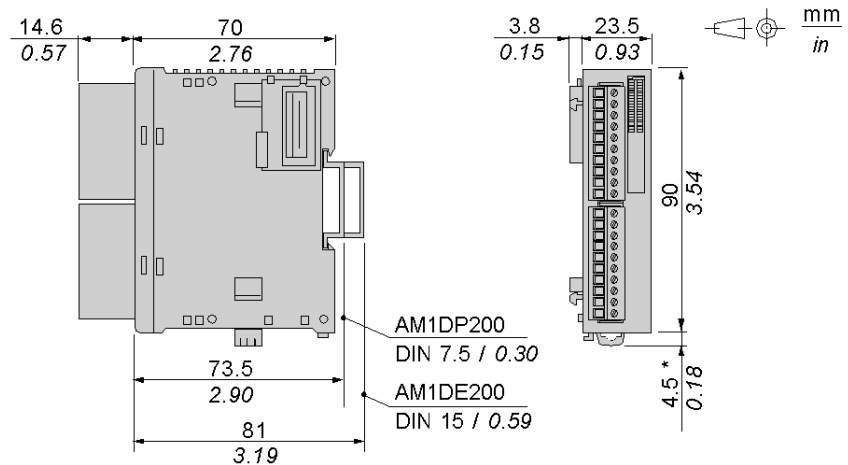

**NOTE:** \* 8.5 mm (0.33 in) when the clip-on lock is pulled out.

### General Characteristics

The following table shows the general characteristics of the **TM2AMM6HT** module:

Characteristic	Specification
Rated power supply voltage	24 VDC
Power supply range	19.2...30 VDC including ripple
Connector insertion/removal durability	100 times minimum
Internal 5 VDC current draw	60 mA
Internal 24 VDC current draw	0 mA
External 24 VDC current draw	80 mA
Weight	85 g (3 oz)

### Inputs Characteristics

The following table shows the inputs characteristics of the **TM2AMM6HT** module:

Characteristic	Voltage input	Current input
Input range	0...10 VDC	4...20 mA
Input impedance	1 M $\Omega$ min	< 250 $\Omega$
Sample duration time	64 ms max.	
Filtering	It is possible to adjust by software the acquisition time for each channel from 16 ms to 64 ms.	
Total input system transfer time	4 x 64 ms + 1 scan time <sup>(1)</sup>	
Input type	Non differential	
Operating mode	Self-scan	
Conversion mode	$\Sigma\Delta$ type ADC	
Input tolerance - maximum deviation at 25°C (77°F)	±0.5 % of full scale	
Input tolerance - temperature drift	±0.015 % of full scale/°C	
Input deviation - repeatable after stabilization time	±0.5 % of full scale	
Input tolerance - nonlinear	±0.4 % of full scale	
Input tolerance - maximum deviation	±1 % of full scale	
Digital resolution	4096 increments (12 bits)	
Input value of LSB	2.5 mV	4.8 $\mu$ A
Data type in application program	0 to 4095 (12 bit data) Custom range up to -32768 to 32767 <sup>(2)</sup>	

Characteristic	Voltage input	Current input
Input data out of range detection	Yes <sup>3</sup>	
Input protection	Against reverse polarity and short circuit	
Noise resistance - maximum temporary deviation during perturbations	±2 % of full scale	
Noise resistance - cable	Twisted-pair shielded cable is necessary	
Noise resistance - crosstalk	1 LSB maximum	
Isolation between inputs	None	
Isolation between inputs and outputs, between inputs and external power supply	800 VAC between inputs and outputs, between channels and PSU	
Isolation between inputs, power supply and internal logic circuits	1500 VAC by photocoupler	
Maximum continuous allowed overload (no damage)	30 VDC	40 mA
Selection of analog input signal type	Using software programming. It is possible to mix the type current and voltage.	
Calibration or verification to maintain rated accuracy	Approximately 10 years	

**NOTE:**

1. Total input system transfer time = sample duration time x active channel number + 1 scan time.
2. The 12-bit data (0 to 4095) processed in the Analog I/O module can be linear-converted to a value between -32768 and 32767. The optional range designation and analog I/O data minimum and maximum values can be selected using data registers allocated to analog I/O modules.
3. When an input error is detected, a corresponding error code is stored to a data register allocated to analog I/O operating status.

## Outputs Characteristics

The following table shows the outputs characteristics of the **TM2AMM6HT** module:

Characteristic	Voltage output	Current output
Output range	0...10 VDC	4...20 mA
Load impedance	2 kΩ minimum	300 Ω maximum
Application load type	Resistive load	
Settling time	20 ms	
Total output system transfer Time	20 ms + 1 scan time	
Output tolerance - maximum deviation at 25° C (77°F)	±0.9 % of full scale	
Output tolerance - temperature drift	±0.015 % of full scale/°C	
Output deviation - repeatable after stabilization time	±1 % of full scale	
Output tolerance - output voltage drop	±1 % of full scale	
Output tolerance - nonlinear	±0.5 % of full scale	
Output tolerance - output ripple	±0.5% of full scale	
Output deviation - overshoot	±0.5% of full scale	
Output tolerance - total deviation	±1.5% of full scale	
Digital resolution	4096 increments (12 bits)	
Output value of LSB	2.5 mV	4.8 μA
Data type in application program	0 to 4095 (12 bit data) Custom range up to -32768 to 32767 <sup>1</sup>	
Noise resistance - maximum temporary deviation during perturbations	±1 % of full scale	
Noise resistance - cable	Twisted-pair shielded cable is necessary for improved noise immunity	
Noise resistance - crosstalk	0.1% of full scale maximum	
Isolation between inputs	None	
Isolation between outputs and external power supply	800 VAC	

Characteristic	Voltage output	Current output
Isolation between outputs and outputs	800 VAC	
Isolation between outputs and internal logic circuits	1500 VAC by photocoupler	
Selection of analog output signal type	Using software programming. It is possible to mix the type current and voltage	
Calibration or verification to maintain rated accuracy	Approximately 10 years	

**NOTE:**

1. The 12-bit data (0 to 4095) processed in the Analog I/O module can be linear-converted to a value between -32768 and 32767. The optional range designation and analog I/O data minimum and maximum values can be selected using data registers allocated to analog I/O modules.

## Connecting the TM2AMM6HT Module

### Wiring Rules

See Wiring Rules and Recommendations (see page 26).

### TM2AMM6HT Wiring Diagram

The following diagram shows the connection of the module I/O.

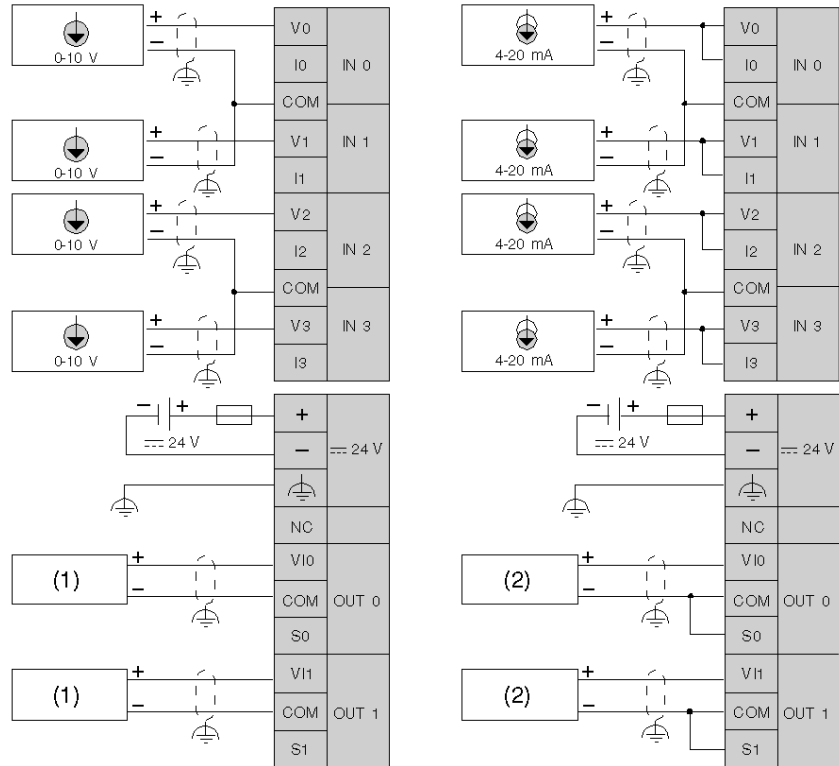

(1) Voltage preactuator

(2) Current preactuator

To use the braid supplied with the module to connect the functional ground.

Connect an appropriate fuse for the applied voltage and current draw, at the position shown in the diagram.

**⚠ WARNING**

**UNINTENDED EQUIPMENT OPERATION**

- Use shielded cables wherever specified for inputs, outputs and communication connections.
- Properly ground the cable shields as indicated in the related documentation.
- Route communication and I/O cables separately from power cables.

**Failure to follow these instructions can result in death, serious injury, or equipment damage.**

**⚠ WARNING**

**UNINTENDED EQUIPMENT OPERATION**

Do not connect wires to unused terminals or terminals marked “Not Connected (N.C.)”.

**Failure to follow these instructions can result in death, serious injury, or equipment damage.**

**NOTE:** To help avoid interference of the analog signals, the power supply of the module must be turned on or off at the same time than the base controller power supply.

**⚠ WARNING**

**UNINTENDED EQUIPMENT OPERATION**

Turn the power supplies for the module and the associated controller on and off at the same time.

**Failure to follow these instructions can result in death, serious injury, or equipment damage.**



---

# TM2ALM3LT Analog Mixed I/O Module

14

---

## Overview

This chapter describes the **TM2ALM3LT** module, its characteristics and its connection to the different sensors.

## What's in this Chapter?

This chapter contains the following topics:

Topic	Page
Presentation of the TM2ALM3LT Module	120
Characteristics of the TM2ALM3LT Module	121
Connecting the TM2ALM3LT Module	125

## Presentation of the TM2ALM3LT Module

### Main Specifications

<b>TM2ALM3LT Main Specifications</b>				
Number of I/O channels	1 Input		2 Outputs	
Signal/sensor type	Thermocouple	Temperature probe	Voltage	Current
Input type	Type J, K and T	Pt100	0...10 Vdc	4...20 mA
Resolution	12 bits (4096 points)			
Connection type	Removable screw terminal block			

# Characteristics of the TM2ALM3LT Module

## Introduction

This section provides a description of the electrical and the I/O characteristics of the **TM2ALM3LT** module.

**⚠ DANGER**

**FIRE HAZARD**

Use only the recommended wire sizes for I/O channels and power supplies.

**Failure to follow these instructions will result in death or serious injury.**

**⚠ WARNING**

**UNINTENDED EQUIPMENT OPERATION**

Do not exceed any of the rated values specified in the following tables.

**Failure to follow these instructions can result in death, serious injury, or equipment damage.**

## Dimensions

The following diagrams show the dimensions for the TM2ALM3LT analog I/O module.

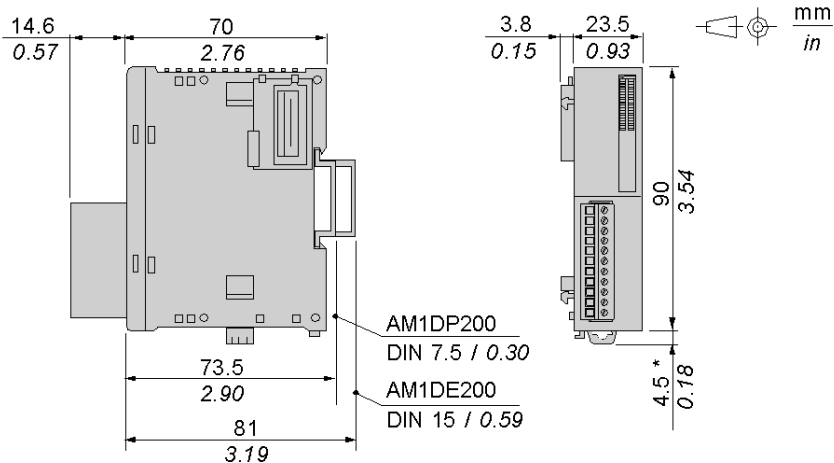

**NOTE:** \* 8.5 mm (0.33 in) when the clip-on lock is pulled out.

### General Characteristics

The following table shows the general characteristics of the **TM2ALM3LT** module:

Characteristic	Specification
Rated power voltage	24 Vdc
Allowable voltage range	19.2...30 Vdc including ripple
Connector insertion/removal durability	100 times minimum
Internal 5 Vdc current draw	60 mA
Internal 24 Vdc current draw	0 mA
External 24 Vdc current draw	80 mA
Weight	85 g (3 oz)

### Inputs Characteristics

The following table shows the inputs characteristics of the **TM2ALM3LT** module:

Characteristic	Thermocouple input	Temperature probe input
Input range	Type K: -270...1370 °C (-454...2498 °F) Type J: -200...760 °C (-328...1400 °F) Type T: -270...400 °C (-454...752 °F)	(RTD) Pt 100 3-wire type -100...500 °C (-148...932 °F)
Input impedance	250 Ω min (TBC)	1 MΩ min
Sample duration time	20 ms max	
Total input system transfer time	80 ms + 1 scan time	
Input type	Differential	
Operating mode	Self-scan	
Conversion mode	ΣΔ type ADC	
Input tolerance - maximum deviation at 25 °C (77 °F)	±0.2 % of full scale plus reference junction compensation accuracy ±4 °C max	±0.2 % of full scale
Input tolerance - temperature drift	±0.006 % of full scale/°C	
Input tolerance - repeatable after stabilization time	±0.5 % of full scale	
Input tolerance - nonlinear	±0.2 % of full scale	
Input tolerance - maximum deviation	±1 % of full scale	
Digital resolution	Type K and J: 14 bits Type T: 12 bits	

Characteristic	Thermocouple input	Temperature probe input
Input value of LSB	K: 0.1 °C (32.18 °F) J: 0.1 °C (32.18 °F) T: 0.1 °C (32.18 °F)	0.1 °C (32.18 °F)
Data type in application program	0 to 4095 (12 bit data) Custom range up to -32768 to 32767 <sup>(2)</sup>	
Input data out of range detection	Yes <sup>3</sup>	
Noise resistance - maximum temporary deviation during perturbations	±3 % maximum when a 500 Vdc clamp voltage is applied to the power and I/O wiring	PT 100: ±1% of full scale
Noise resistance - cable	Twisted-pair shielded cable is necessary	
Isolation between output and external power supply	500 Vac	
Isolation between output, power supply and internal logic circuits	500 Vac by photocoupler	
Selection of analog input signal type	Using software programming. It is possible to mix the type of input on the module.	
Calibration or verification to maintain rated accuracy	Approximately 10 years	

**NOTE:**

1. The 12, 13 or 14-bit data (0 to 4095) and 10-bit data (0 to 1023) processed in the Analog I/O module can be linear-converted to a value between -32768 and 32767. The optional range designation and analog I/O data minimum and maximum values can be selected using data registers allocated to analog I/O modules.
2. When an input error is detected, a corresponding error code is stored to a data register allocated to analog I/O operating status.

**Outputs Characteristics**

The following table shows the outputs characteristics of the **TM2ALM3LT** module:

Characteristic	Voltage output	Current output
Output range	0...10 Vdc	4...20 mA
Load impedance	> 2 kΩ	300 Ω maximum
Application load type	Resistive load	
Settling time	10 ms	
Total output system transfer Time	10 ms + 1 scan time	
Output tolerance - maximum deviation at 25° C (77° F)	±0.2% of full scale	

Characteristic	Voltage output	Current output
Output tolerance - temperature drift	$\pm 0.015\%$ of full scale/ $^{\circ}\text{C}$	
Output tolerance - repeatable after stabilization time	$\pm 0.5\%$ of full scale	
Output tolerance - output voltage drop	$\pm 1\%$ of full scale	
Output tolerance - nonlinear	$\pm 0.2\%$ of full scale	
Output tolerance - output ripple	1 LSB maximum	
Output tolerance - overshoot	0%	
Output tolerance - total deviation	$\pm 1\%$ of full scale	
Digital resolution	4096 increments (12 bits)	
Output value of LSB	2.5 mV	4.8 $\mu\text{A}$
Data type in application program	0 to 4095 (12 bit data) Custom range up to -32768 to 32767 <sup>1</sup>	
External power supply connection	Detected	Detected <sup>2</sup>
Noise resistance - maximum temporary deviation during perturbations	$\pm 1\%$ of full scale	
Noise resistance - cable	Twisted-pair shielded cable is necessary	
Isolation between output and external power supply	500 Vac	
Isolation between inputs, power supply and internal logic circuits	500 Vac by photocoupler	
Selection of analog output signal type	Using software programming	
Calibration or verification to maintain rated accuracy	Approximately 10 years	

**NOTE:**

1. The 12-bit data (0 to 4095) and 10-bit data (0 to 1023) processed in the Analog I/O module can be linear-converted to a value between -32768 and 32767. The optional range designation and analog I/O data minimum and maximum values can be selected using data registers allocated to analog I/O modules.
2. When an output error is detected, a corresponding error code is stored to a data register allocated to analog I/O operating status.

# Connecting the TM2ALM3LT Module

## Wiring Rules

See Wiring Rules and Recommendations (see page 26).

## TM2ALM3LT Wiring Diagram

The following diagram shows the connection of the module I/O.

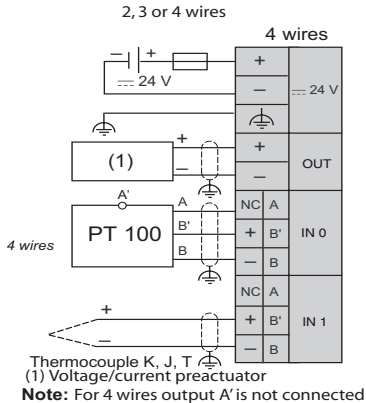

To use the braid supplied with the module to connect the functional ground.

- Connect an appropriate fuse for the applied voltage and current draw, at the position shown in the diagram.
- When connecting an PT100 temperature probe, connect the wires to terminals A, B', and B of input channel 0 or 1.
- When connecting a thermocouple, connect the two wires to terminals B' and B of input channel 0 or 1.

⚠ DANGER

FIRE HAZARD

Use only the recommended wire sizes for I/O channels and power supplies.

Failure to follow these instructions will result in death or serious injury.

** WARNING**

**UNINTENDED EQUIPMENT OPERATION**

- Use shielded cables wherever specified for inputs, outputs and communication connections.
- Properly ground the cable shields as indicated in the related documentation.
- Route communication and I/O cables separately from power cables.

**Failure to follow these instructions can result in death, serious injury, or equipment damage.**

** WARNING**

**UNINTENDED EQUIPMENT OPERATION**

Do not connect wires to unused terminals or terminals marked “Not Connected (N.C.)”.

**Failure to follow these instructions can result in death, serious injury, or equipment damage.**

**NOTE:** To help avoid interference of the analog signals, the power supply of the module must be turned on or off at the same time than the base controller power supply.

** WARNING**

**UNINTENDED EQUIPMENT OPERATION**

Turn the power supplies for the module and the associated controller on and off at the same time.

**Failure to follow these instructions can result in death, serious injury, or equipment damage.**

---

## Certifications and Standards

15

---

### Certifications and Standards

#### Introduction

TM2 Analog I/O modules comply with the main national and international standards concerning electronic industrial control devices.

Reference	CE	TüV IEC EN 61131-2 edition 2 2003	UL	CSA	UL / CSA Class I, Div. 2	cULus	Nemko - GL - LR - DNV
TM2ALM3LT	X	X	X	X	X	–	X
TM2AMI2HT	X	X	X	X	X	–	X
TM2AMI2LT	X	–	X	X	X	–	–
TM2AMI4LT	X	–	X	X	X	–	–
TM2AMI8HT	X	–	X	X	X	–	–
TM2AMM3HT	X	X	X	X	X	–	X
TM2AMM6HT	X	–	–	–	X	X	–
TM2AMO1HT	X	X	X	X	X	–	X
TM2ARI8HT	X	–	X	X	X	–	–
TM2AVO2HT	X	–	X	X	X	–	–
TM2ARI8LRJ	X	–	X	X	X	–	–
TM2ARI8LT	X	–	X	X	X	–	–



---

# Glossary

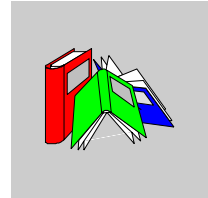

---

## A

### analog input

An *analog input* module contains circuits that convert an analog DC input signal to a digital value that can be manipulated by the processor. By implication, the analog input is usually direct. That means a data table value directly reflects the analog signal value.

### analog output

An *analog output* module contains circuits that transmit an analog DC signal proportional to a digital value input to the module from the processor. By implication, these analog outputs are usually direct. That means a data table value directly controls the analog signal value.

### AWG

The *american wire gauge* standard specifies wire gauges in North America.

## D

### De-rating

*De-rating* describes a reduction in an operating specification. For devices in general it is usually a specified reduction in nominal power to facilitate operation at increased ambient conditions like higher temperatures or higher altitudes.

**digital I/O**

A *digital input or output* has an individual circuit connection at the electronic module that corresponds directly to a data table bit that holds the value of the signal at that I/O circuit. It gives the control logic digital access to I/O values.

**DIN**

*Deutsches Institut für Normung* is a German institution that sets engineering and dimensional standards.

**E**

**expansion connector**

A connector to attach expansion I/O modules.

**expansion connector sticker**

A cover to protect the expansion connector.

**expansion I/O module**

An *expansion input or output module* is either a digital or analog module that adds additional I/O to the base controller.

**expert I/O**

*Expert I/Os* are dedicated modules or channels for advanced features. These features are generally embedded in the module in order to not use the resources of the PLC Controller and to allow a fast response time, depending of the feature. Regarding the function, it could be considered as a “stand alone” module, because the function is independent of the Controller processing cycle, it just exchanges some information with the Controller CPU.

**F**

**FE**

*Functional ground* is the point of a system or device that must be grounded to help prevent equipment damage.

**FG**

*frequency generator*

**free wire**

The end of a digital I/O cable whose wires do not have a connector. This scheme provides connectivity from controller to digital I/O points.

**H****HSC**

*high-speed counter.*

**I****I/O**

*input/output*

**I/O terminals**

An *input/output terminal* on the front of an expansion I/O module connects input and output signals.

**IEC**

The *international electrotechnical commission* is a non-profit and non-governmental international standards organization that prepares and publishes international standards for all electrical, electronic, and related technologies.

**input filter**

An *input filter* is a special function that rejects input noises. It is useful for eliminating input noises and chatter in limit switches. All inputs provide a level of input filtering using the hardware. Additional filtering with software is also configurable through the programing or the configuration software.

**input terminals**

An *input terminal* on the front of an expansion I/O module connects input signals from input devices (such as sensors, push buttons, and limit switches). For some modules, input terminals accept both sink and source DC input signals.

**IP 20**

*Ingress protection* rating according to IEC 60529. IP20 modules are protected against ingress and contact of objects larger than 12.5 mm. The module is not protected against harmful ingress of water.

**L**

**LED**

A *light emitting diode* is an indicator that lights up when electricity passes through it.

**N**

**NC**

A *normally closed* contact is a contact pair that is closed when the actuator is de-energized (no power is applied) and open when the actuator is energized (power is applied).

**NO**

A *normally open* contact is a contact pair that is open when the actuator is de-energized (no power is applied) and closed when the actuator is energized (power is applied).

**O**

**output terminals**

An *output terminal* connects output signals to output devices (such as electromechanical relays and solenoid valves).

**P**

**PE**

*Protective ground* is a return line across the bus for fault currents generated at a sensor or actuator device in the control system.

**Pt100/Pt1000**

Platinum resistance thermometer are characterized by their nominal resistance  $R_0$  at a temperature of  $0^\circ \text{C}$ .

- Pt100 ( $R_0 = 100 \text{ Ohm}$ )
- Pt1000 ( $R_0 = 1 \text{ kOhm}$ )

**S****sink input**

A *sink input* is a wiring arrangement in which the device provides current to the input electronic module. A sink input is referenced to 0 Vdc.

**source output**

A *source output* is a wiring arrangement in which the output electronic module provides current to the device. A source output is referenced to +24 Vdc.



---

# Index

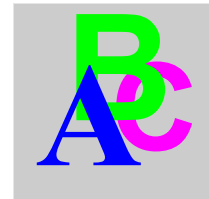

---

## A

- Accessories, *16*
- Analog I/O modules, *13*
  - Physical description, *15*
  - Specifications, *13*
- Assembling to a controller, *20*

## C

- certifications and standards, *127*
- Controllers
  - Disassembling a module, *22*

## D

- Dimensions
  - TM2ALM3LT, *121*
  - TM2AMI2HT, *35*
  - TM2AMI2LT, *41*
  - TM2AMI4LT, *47*
  - TM2AMI8HT, *55*
  - TM2AMM3HT, *103*
  - TM2AMM6HT, *111*
  - TM2AMO1HT, *87*
  - TM2ARI8HT, *63*
  - TM2ARI8LRJ, *72*
  - TM2ARI8LT, *80*
  - TM2AVO2HT, *95*

## G

- General characteristics
  - TM2ALM3LT, *122*
  - TM2AMI2HT, *36*
  - TM2AMI2LT, *42*
  - TM2AMI4LT, *48*
  - TM2AMI8HT, *56*
  - TM2AMM3HT, *104*
  - TM2AMM6HT, *112*
  - TM2AMO1HT, *88*
  - TM2ARI8HT, *64*
  - TM2ARI8LRJ, *72*
  - TM2ARI8LT, *80*
  - TM2AVO2HT, *96*

## I

- Input characteristics
  - TM2AMI2LT, *42*
  - TM2AMO1HT, *88*
  - TM2ARI8HT, *64*
  - TM2ARI8LRJ, *73*
  - TM2ARI8LT, *81*
  - TM2AVO2HT, *96*
- Inputs characteristics
  - TM2ALM3LT, *122*
  - TM2AMI2HT, *36*
  - TM2AMI4LT, *48*
  - TM2AMI8HT, *56*
  - TM2AMM3HT, *104*
  - TM2AMM6HT, *112*
- Installing on a mounting rail, *23*

## M

- Mounting hole layout, 25
- Mounting Position, 19
- Mounting rail
  - 15 mm AM1DE200 rail, 16
  - 725 mm AM1DP200 rail, 16
- Mounting strip installation, 25

## O

- Outputs characteristics
  - TM2ALM3LT, 123
  - TM2AMM3HT, 105
  - TM2AMM6HT, 114

## P

- Physical description
  - Connector RJ11, 15
  - Terminal block, 15

## R

- Removing from a mounting rail, 24

## S

- Specifications
  - Analog I/O modules, 13

## T

- Terminal Block End Clamp type
  - AB1AB8P35, 16
- TM2 I/O modules
  - Environmental specifications, 31
  - TM2ALM3LT, 119, 120, 121, 125
  - TM2AMI2HT, 33, 34, 35, 38
  - TM2AMI2LT, 39, 40, 41, 44
  - TM2AMI4LT, 45, 46, 47, 50
  - TM2AMI8HT, 53, 54, 55, 58
  - TM2AMM3HT, 101, 102, 103, 107
  - TM2AMM6HT, 109, 110, 111, 116
  - TM2AMO1HT, 85, 86, 87, 90

- TM2ARI8HT, 61, 62, 63, 66
- TM2ARI8LRJ, 69, 70, 71, 75
- TM2ARI8LT, 78, 79, 83
- TM2ARI8LTARI8LT, 77
- TM2AV02HT, 94
- TM2AVO2HT, 93, 95, 98
- TM2XMTGB, 17
- TWDXMT5 mounting strip, 17

## W

- Wiring diagram
  - TM2ALM3LT, 125
  - TM2AMI2HT, 38
  - TM2AMI2LT, 44
  - TM2AMI4LT, 50
  - TM2AMI8HT, 58
  - TM2AMM3HT, 107
  - TM2AMM6HT, 116
  - TM2AMO1HT, 90
  - TM2ARI8HT, 66
  - TM2ARI8LRJ, 75
  - TM2ARI8LT, 83
  - TM2AVO2HT, 98
- wiring requirements, 26