

Alarm Stages

The AP range of air horns are suitable for industrial environments where very high sound and low frequency outputs are required for signalling over medium to larger size areas. The units produce the classic 'fog horn' sound and are suitable for indoor or outdoor use.

To maintain the IP rating of the horn, always ensure that the trumpet is mounted at slightly less than horizontal (tilted downwards). This helps keep the inner trumpet free from fluid & debris build up.

Part Code	Air Pressure	Air Consumption	Frequency	dB
AP198M	55-140 psi	50-133 L/min	660 Hz	125
AP360M	55-140 psi	50-133 L/min	387 Hz	125
AP450M	55-140 psi	50-133 L/min	307 Hz	125

Key Features

- Ingress Protection: Weatherproof to IP66
- Material: Housing & Locknut - Aluminium
Trumpet & Adapter - Brass
- Operating Temperature: -20°C to +70°C

Maintenance

The horn contains no part that requires maintenance. However check air connection to the unit from time to time to ensure maximum air pressure is maintained. Ensure the interior of trumpet is free from debris build up.



INSTALLATION & TECHNICAL INFORMATION

PLEASE READ PRIOR TO INSTALLATION



AP198, 360, 450 Series Pneumatic Air Driven Horns

AUDIBLE SIGNALLING DEVICES

APPROVED AND
CONFORMITIES



1.0 Introduction

The airhorn is a pneumatic device powered by compressed air. Air flows into the horn via a small aperture in the cast diaphragm housing causing the diaphragm inside to vibrate creating sound waves. The length of the trumpet will dictate the wavelength of sound waves produced by the unit and therefore the frequency of the note or pitch. In general, the lower the frequency of the note produced, the further the sound will travel.

Output.

The Horn should be mounted using the two mounting 'lugs' on either side of the diaphragm housing utilising the 2 x 8.3mm (5/16") mounting holes. The unit should only be attached to services that can adequately support its weight.

Once the ideal position for the unit has been chosen and the horn secured in place, attach a suitably constructed and rated airline/pipe, to suit the air supply, with a bore of 5/16" to the 1/4" BSP adapter. The airline/pipe should be suitably clamped into place over the BSP adapter ensuring no air leakage.

To use the horn on a reduced air supply of 10-45psi slacken the 38mm A/F locknut securing the trumpet to the diaphragm housing and rotate the trumpet in an anti-clockwise direction whilst the unit is being operated until the most audible and clear note is obtained. Then re-tighten the locknut. Frequency & dB output will be effected. Ear defenders must be worn whilst carrying out this procedure.

General Installation Notes

- Installation must be carried out in accordance with the latest codes and regulations by a qualified person.
- Avoid mounting the horn where it will be subject to excessive vibration.
- Do not exceed maximum stated PSI air pressure.

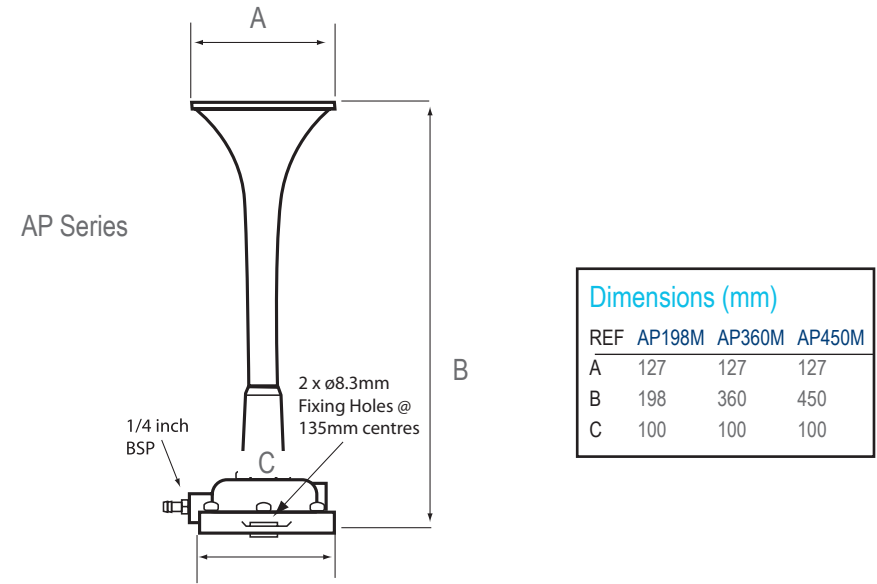

Specific Product Health & Safety Issues

- Prior to installation the user & installer should perform a risk assessment with regard to the horns installation and safety when in use.
- The air horn audibility level at 1 metre distance may be up to 125dB and therefore care must be taken in the positioning of the unit so that it is not in close proximity to people. (Minimum recommended segregation distance between air horn and people of at least 5 metres - 16.4ft).

During operation of the air horn any personnel who are in close proximity, must wear ear defenders.

WARNING - Damage may be caused to a persons hearing if they are in close proximity to the air horn when activated and they are not equipped with adequate protective equipment in the form of ear defenders.

- Do not remove or change any component parts of the air horn for other manufacturer's products.