

FEMALE END VIEW

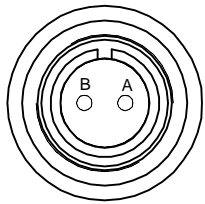

A = WHITE
B = BLACK

CONNECTOR
TYPE/STYLE - MS 3106M
SHELL SIZE - 10SL
INSERT ARRANGEMENT - 4S

SPECIFICATIONS

CONTACT CARRIER MATERIAL	NEOPRENE
MOLDED HEAD MATERIAL/COLOR	PVC/BLACK
CONTACT MATERIAL/PLATING	COPPER ALLOY/SILVER
COUPLING NUT MATERIAL/PLATING	ALUMINUM ALLOY/OLIVE DRAB CHROMATE
MOLD SLEEVE	ALUMINUM/BLACK ANODIZED
RATED CURRENT [A]	13.0 A
RATED VOLTAGE [V]	500 V
OUTER JACKET MATERIAL/COLOR	PVC/YELLOW
CONDUCTOR INSULATION MATERIAL	PVC
NUMBER OF CONDUCTORS	2x16 AWG
TEMPERATURE RATING	-40°C to +105°C (-40°F to +221°F)
PROTECTION CLASS	MEETS NEMA 1,3,4,6P AND IEC IP67,IP68
CONNECTOR TYPE	MIL-DTL-5015

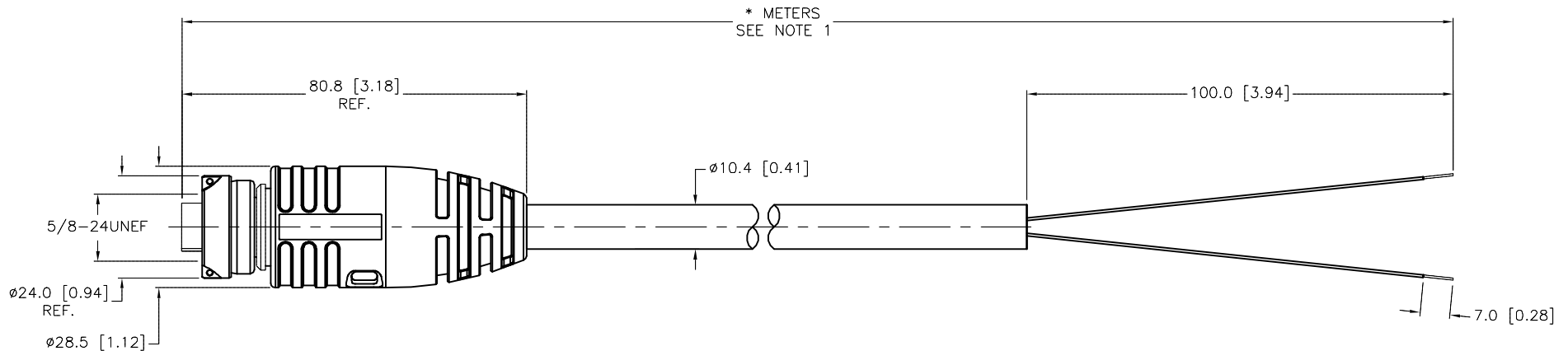

* METERS
SEE NOTE 1

CABLE LENGTH	TOLERANCE *
ALL LENGTHS	+ 4% (OR 50mm) OF LENGTH - 0% (OR 0mm) OF LENGTH WHICHEVER IS GREATER
STRIP LENGTH	TOLERANCE *
0-7mm	±0.5mm
8-29mm	±1.0mm
30-49mm	±2.0mm
50-69mm	±3.0mm
70-100mm	±4.0mm
OVER 100mm	±5.0mm

* UNLESS OTHERWISE SPECIFIED

NOTES:

1. "*" INDICATES CABLE LENGTH IN METERS. CONTACT TURCK TO ORDER SPECIFIC LENGTH.

SOURCE DRAWING - FOR REFERENCE ONLY

RELATED DOCUMENTS 1. 2. 3. 4.	3RD ANGLE PROJECTION 	THIS DRAWING IS CONFIDENTIAL AND THE PROPERTY OF TURCK INC. USE OF THIS DOCUMENT WITHOUT WRITTEN PERMISSION IS PROHIBITED.		TURCK INC High Technology Sensors and Automation Controls 3000 CAMPUS DRIVE MINNEAPOLIS, MN 55441 1-800-544-7769 (763) 553-7300 (763) 553-0708 fax turck.com	
		DRFT KMY	DATE 04/20/12	DESCRIPTION MS 3106M-10SL-4S-0561-*	
MATERIAL SEE SPECIFICATIONS	ALL DIMENSIONS DISPLAYED ON THIS DRAWING ARE FOR REFERENCE ONLY	APVD J.B.	SCALE 1=1.5	IDENTIFICATION NO.	
FINISH SEE SPECIFICATIONS		UNIT OF MEASUREMENT MILLIMETER [INCH]		REV B	
DO NOT SCALE THIS DRAWING		FILE: 777028757		SHEET 1 OF 1	

B	UPDATE END VIEW SPECIFICATION PER ECO	KMY	01/23/13	40996
REV	DESCRIPTION	BY	DATE	ECO NO.