

375W Quad Output with PFC Function

QP-375 series



Features :

- Universal AC input / Full range
- Built-in active PFC function, PF>0.95
- Protections: Short circuit / Overload / Over voltage / Over temperature
- Forced air cooling by built-in DC fan
- CH3,4 are isolated from other outputs and the polarity can be reversed
- No minimum load requirement for CH2,3,4
- All output can be adjustable from -5~+10%
- With power good and fail signal output
- Built-in remote ON-OFF control
- Fixed switching frequency at 100KHz
- 3 years warranty



SPECIFICATION

MODEL		413-982											
OUTPUT	OUTPUT NUMBER	CH1	CH2	CH3	CH4	CH1	CH2	CH3	CH4	CH1	CH2	CH3	CH4
	DC VOLTAGE	5V	+12V	12V	12V	+5V	+12V	12V	5V	5V	+12V	15V	15V
	RATED CURRENT	30A	10A	6A	3A	30A	10A	6A	3A	30A	9A	4A	4A
	CURRENT RANGE	3.5 ~ 40A	0 ~ 16A	0 ~ 6A	0 ~ 3A	3.5 ~ 40A	0 ~ 16A	0 ~ 6A	0 ~ 3A	3.5 ~ 40A	0 ~ 16A	0 ~ 4A	0 ~ 4A
	RATED POWER(max.)	378W				357W				378W			
	RIPPLE & NOISE (max.) Note.2	100mVp-p	150mVp-p	150mVp-p	50mVp-p	100mVp-p	120mVp-p	120mVp-p	50mVp-p	100mVp-p	150mVp-p	150mVp-p	240mVp-p
	VOLTAGE ADJ. RANGE	4.75 ~ 5.5V	11.4 ~ 13.2V	11.4 ~ 13.2V	11.4 ~ 13.2V	4.75 ~ 5.5V	11.4 ~ 13.2V	11.4 ~ 13.2V	-----	4.75 ~ 5.5V	11.4 ~ 13.2V	14.3 ~ 16.5V	14.3 ~ 16.5V
	VOLTAGE TOLERANCE Note.3	±1.0%	±1.0%	±1.0%	±1.0%	±1.0%	±1.0%	±1.0%	±1.0%	±1.0%	±1.0%	±1.0%	±1.0%
	LINE REGULATION	±0.5%	±0.5%	±0.5%	±0.5%	±0.5%	±0.5%	±0.5%	±0.5%	±0.5%	±0.5%	±0.5%	±0.5%
	LOAD REGULATION	±0.8%	±0.8%	±0.8%	±0.8%	±0.8%	±0.8%	±0.8%	±0.8%	±0.8%	±0.8%	±0.8%	±0.8%
	SETUP, RISE TIME	800ms, 50ms at full load											
	HOLD UP TIME (Typ.)	36ms at full load											
	INPUT	VOLTAGE RANGE Note.7	85 ~ 264VAC		120 ~ 370VDC								
FREQUENCY RANGE		47 ~ 63Hz											
POWER FACTOR (Typ.)		PF>0.95/230VAC		PF>0.98/115VAC at full load									
EFFICIENCY (Typ.)		77%				77%				77%			
AC CURRENT (Typ.)		6A/115VAC		3A/230VAC									
INRUSH CURRENT (Typ.)		COLD START 45A											
LEAKAGE CURRENT	<2mA / 240VAC												
PROTECTION	OVERLOAD	105 ~ 135% rated output power Protection type : Hiccup mode, recovers automatically after fault condition is removed											
	OVER VOLTAGE	CH1: 5.75 ~ 6.75V Protection type : Shut down o/p voltage, re-power on to recover											
	OVER TEMPERATURE	80°C ±5°C (TSW1) Detect on heatsink of Q1, Q2 power transistor Protection type : Shut down o/p voltage, recovers automatically after temperature goes down											
FUNCTION	POWER GOOD / POWER FAIL(OPTIONAL)	10ms/1ms											
	REMOTE CONTROL	RC+/RC-: 0 ~ 0.8V POWER ON; 4V ~ 10V POWER OFF											
ENVIRONMENT	WORKING TEMP.	-10 ~ +60°C (Refer to output load derating curve)											
	WORKING HUMIDITY	20 ~ 90% RH non-condensing											
	STORAGE TEMP., HUMIDITY	-20 ~ +85°C, 10 ~ 95% RH											
	TEMP. COEFFICIENT	±0.03%/°C (0~50°C)											
SAFETY & EMC (Note 4)	VIBRATION	10 ~ 500Hz, 2G 10min / 1cycle, 60min. each along X, Y, Z axes											
	SAFETY STANDARDS	UL60950-1, TUV EN60950-1 Approved											
	WITHSTAND VOLTAGE	I/P-O/P: 3KVAC		I/P-FG: 1.5KVAC		O/P-FG: 0.5KVAC							
	ISOLATION RESISTANCE	I/P-O/P, I/P-FG, O/P-FG: 100M Ohms/500VDC											
	EMI CONDUCTION & RADIATION	Compliance to EN55022 (CISPR22) Class B											
OTHERS	HARMONIC CURRENT	Compliance to EN61000-3-2, -3											
	EMS IMMUNITY	Compliance to EN61000-4-2, 3, 4, 5, 6, 8, 11; ENV50204, EN55024, Light industry level, criteria A											
	MTBF	75.9K hrs min.		MIL-HDBK-217F (25°C)									
NOTE	DIMENSION	280*127*83.5mm (L*W*H)											
	PACKING	2.4Kg, 6pcs/14.8Kg/1.45CUFT											
<p>1. All parameters NOT specially mentioned are measured at 230VAC input, rated load and 25°C of ambient temperature. 2. Ripple & noise are measured at 20MHz of bandwidth by using a 12" twisted pair-wire terminated with a 0.1uF & 47uF parallel capacitor. 3. Tolerance : includes set up tolerance, line regulation and load regulation. 4. The power supply is considered a component which will be installed into a final equipment. The final equipment must be re-confirmed that it still meets EMC directives. 5. Peak current can not exceed 60 sec. 6. Isolated CH3 & CH4 maybe series connected or can be used as positive or negative outputs. 7. Derating may be needed under low input voltages. Please check the derating curve for more details.</p>													



■ Features :

- Universal AC input / Full range
- Built-in active PFC function, PF>0.95
- Protections: Short circuit / Overload / Over voltage / Over temperature
- Forced air cooling by built-in DC fan
- CH3,4 are isolated from other outputs and the polarity can be reversed
- No minimum load requirement for CH2,3,4
- All output can be adjustable from -5~+10%
- With power good and fail signal output
- Built-in remote ON-OFF control
- Fixed switching frequency at 100KHz
- 3 years warranty



SPECIFICATION

MODEL		414-115								
OUTPUT	OUTPUT NUMBER	CH1	CH2	CH3	CH4	CH1	CH2	CH3	CH4	
	DC VOLTAGE	+5V	+12V	12V	24V	+5V	+12V	24V	24V	
	RATED CURRENT	30A	9A	4A	3A	30A	9A	3A	2A	
	CURRENT RANGE	3.5 ~ 40A	0 ~ 16A	0 ~ 6A	0 ~ 3A	3.5 ~ 40A	0 ~ 16A	0 ~ 4A	0 ~ 3A	
	RATED POWER(max.)	378W				378W				
	RIPPLE & NOISE (max.) Note.2	100mVp-p	120mVp-p	120mVp-p	240mVp-p	100mVp-p	120mVp-p	120mVp-p	240mVp-p	
	VOLTAGE ADJ. RANGE	4.75 ~ 5.5V	11.4 ~ 13.2V	11.4 ~ 13.2V	22.8 ~ 26.4V	4.75 ~ 5.5V	11.4 ~ 13.2V	22.8 ~ 26.4V	22.8 ~ 26.4V	
	VOLTAGE TOLERANCE Note.3	±1.0%	±1.0%	±1.0%	±1.0%	±1.0%	±1.0%	±1.0%	±1.0%	
	LINE REGULATION	±0.5%	±0.5%	±0.5%	±0.5%	±0.5%	±0.5%	±0.5%	±0.5%	
	LOAD REGULATION	±0.8%	±0.8%	±0.8%	±0.8%	±0.8%	±0.8%	±0.8%	±0.8%	
SETUP, RISE TIME	800ms, 50ms at full load									
HOLD UP TIME (Typ.)	36ms at full load									
INPUT	VOLTAGE RANGE Note.7	85 ~ 264VAC		120 ~ 370VDC						
	FREQUENCY RANGE	47 ~ 63Hz								
	POWER FACTOR (Typ.)	PF>0.95/230VAC		PF>0.98/115VAC at full load						
	EFFICIENCY (Typ.)	78%				78%				
	AC CURRENT (Typ.)	6A/115VAC		3A/230VAC						
	INRUSH CURRENT (Typ.)	COLD START 45A								
LEAKAGE CURRENT	<2mA / 240VAC									
PROTECTION	OVERLOAD	105 ~ 135% rated output power Protection type : Hiccup mode, recovers automatically after fault condition is removed								
	OVER VOLTAGE	CH1: 5.75 ~ 6.75V Protection type : Shut down o/p voltage, re-power on to recover								
	OVER TEMPERATURE	80°C ±5°C (TSW1): Detect on heatsink of Q1, Q2 power transistor Protection type : Shut down o/p voltage, recovers automatically after temperature goes down								
FUNCTION	POWER GOOD / POWER FAIL(OPTIONAL)	10ms/1ms								
	REMOTE CONTROL	RC+/RC-: 0 ~ 0.8V POWER ON; 4V ~ 10V POWER OFF								
ENVIRONMENT	WORKING TEMP.	-10 ~ +60°C (Refer to output load derating curve)								
	WORKING HUMIDITY	20 ~ 90% RH non-condensing								
	STORAGE TEMP., HUMIDITY	-20 ~ +85°C, 10 ~ 95% RH								
	TEMP. COEFFICIENT	±0.03%/°C (0~50°C)								
SAFETY & EMC (Note 5)	VIBRATION	10 ~ 500Hz, 2G 10min./1cycle, 60min. each along X, Y, Z axes								
	SAFETY STANDARDS	UL60950-1, TUV EN60950-1 Approved								
	WITHSTAND VOLTAGE	I/P-O/P: 3KVAC I/P-FG: 1.5KVAC O/P-FG: 0.5KVAC								
	ISOLATION RESISTANCE	I/P-O/P, I/P-FG, O/P-FG: 100M Ohms/500VDC								
	EMI CONDUCTION & RADIATION	Compliance to EN55022 (CISPR22) Class B								
	HARMONIC CURRENT	Compliance to EN61000-3-2,-3								
OTHERS	EMS IMMUNITY	Compliance to EN61000-4-2,3,4,5,6,8,11; ENV50204, EN55024, Light industry level, criteria A								
	MTBF	75.9K hrs min. MIL-HDBK-217F (25°C)								
NOTE	DIMENSION	280*127*63.5mm (L*W*H)								
	PACKING	2.4Kg; 6pcs/14.8Kg/1.45CUFT								
<p>1. All parameters NOT specially mentioned are measured at 230VAC input, rated load and 25°C of ambient temperature. 2. Ripple & noise are measured at 20MHz of bandwidth by using a 12" twisted pair-wire terminated with a 0.1uf & 47uf parallel capacitor. 3. Tolerance : includes set up tolerance, line regulation and load regulation. 4. The power supply is considered a component which will be installed into a final equipment. The final equipment must be re-confirmed that it still meets EMC directives. 5. Peak current can not exceed 60 sec. 6. Isolated CH3 & CH4 maybe series connected or can be used as positive or negative outputs. 7. Derating may be needed under low input voltages. Please check the derating curve for more details.</p>										

Mechanical Specification

Case No. 927A Unit:mm

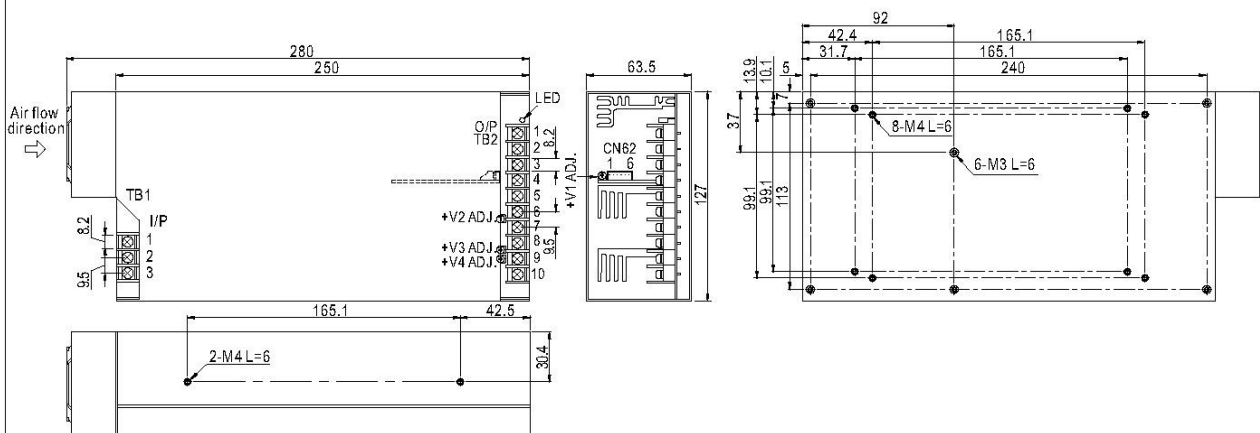

AC Input Terminal Pin No. Assignment

Pin No.	Assignment
1	AC/L
2	AC/N
3	FG \perp

DC Output Terminal Pin No. Assignment

Pin No.	Assignment	Pin No.	Assignment
1,2	+V1	8	-V3
3,4,5	COM(V1 and V2)	9	+V4
6	+V2	10	-V4
7	+V3		

CN62 Pin No. Assignment : JST S6B-XH or equivalent

Pin No.	Assignment	Mating Housing	Terminal
1	PF(Power good / Fail signal)	JST XHP or equivalent	JST SXH-001T-P0.6 or equivalent
2	GND		
3	RS-		
4	RS+		
5	RC-		
6	RC+		

Block Diagram

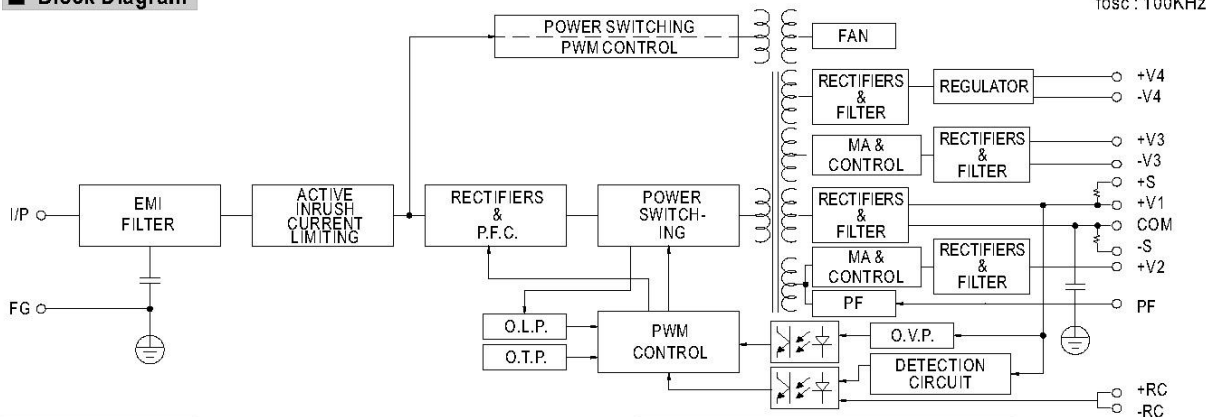

Derating Curve

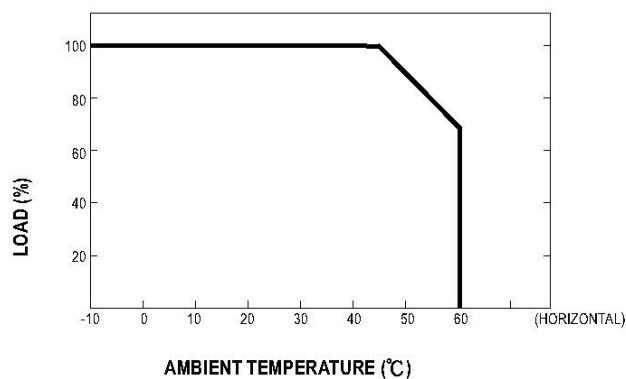

Output Derating VS Input Voltage

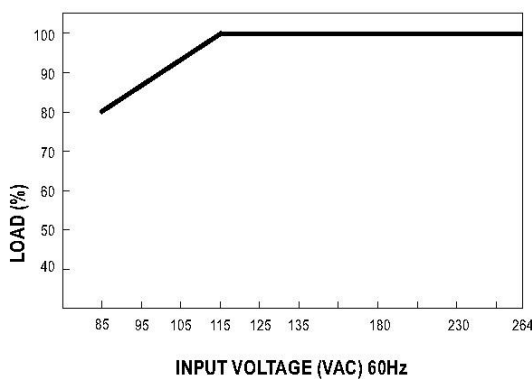



■ Features :

- Universal AC input / Full range
- Built-in active PFC function, PF>0.95
- Protections: Short circuit / Overload / Over voltage / Over temperature
- Forced air cooling by built-in DC fan
- CH3,4 are isolated from other outputs and the polarity can be reversed
- No minimum load requirement for CH2,3,4
- All output can be adjustable from -5~+10%
- With power good and fail signal output
- Built-in remote ON-OFF control
- Fixed switching frequency at 100KHz
- 3 years warranty



SPECIFICATION

MODEL		414-119							
OUTPUT	OUTPUT NUMBER	CH1	CH2	CH3	CH4	CH1	CH2	CH3	CH4
	DC VOLTAGE	+24V	+5V	12V	12V	+24V	+5V	15V	15V
	RATED CURRENT	10A	10A	4A	4A	10A	10A	4A	4A
	CURRENT RANGE	1 ~ 10A	0 ~ 16A	0 ~ 4A	0 ~ 4A	1 ~ 10A	0 ~ 10A	0 ~ 4A	0 ~ 4A
	RATED POWER(max.)	386W				410W			
	RIPPLE & NOISE (max.) Note.2	240mVp-p	50mVp-p	120mVp-p	120mVp-p	240mVp-p	50mVp-p	150mVp-p	150mVp-p
	VOLTAGE ADJ. RANGE	21.6 ~ 26.4V	4.5 ~ 5.5V	10.8 ~ 13.2V	10.8 ~ 13.2V	21.6 ~ 26.4V	4.5 ~ 5.5V	13.5 ~ 16.5V	13.5 ~ 16.5V
	VOLTAGE TOLERANCE Note.3	±1.0%	±1.0%	±1.0%	±1.0%	±1.0%	±1.0%	±1.0%	±1.0%
	LINE REGULATION	±0.5%	±0.5%	±0.5%	±0.5%	±0.5%	±0.5%	±0.5%	±0.5%
	LOAD REGULATION	±0.8%	±0.8%	±0.8%	±0.8%	±0.8%	±0.8%	±0.8%	±0.8%
	SETUP, RISE TIME	800ms, 50ms at full load							
HOLD UP TIME (Typ.)	36ms at full load								
INPUT	VOLTAGE RANGE Note.7	85 ~ 264VAC		120 ~ 370VDC					
	FREQUENCY RANGE	47 ~ 63Hz							
	POWER FACTOR (Typ.)	PF>0.95/230VAC		PF>0.98/115VAC at full load					
	EFFICIENCY (Typ.)	78%				80%			
	AC CURRENT (Typ.)	6A/115VAC		3A/230VAC					
	INRUSH CURRENT (Typ.)	COLD START 45A							
	LEAKAGE CURRENT	<2mA / 240VAC							
PROTECTION	OVERLOAD	105 ~ 135% rated output power Protection type : Hiccup mode, recovers automatically after condition is removed							
	OVER VOLTAGE	CH1:27.6 ~ 32.4V Protection type : Shut down o/p voltage, re-power on to recover							
	OVER TEMPERATURE	80°C ±5°C (TSW1) Detect on heatsink of Q1, Q2 power transistor Protection type : Shut down o/p voltage, recovers automatically after temperature goes down							
FUNCTION	POWER GOOD / POWER FAIL(OPTIONAL)	10ms/1ms							
	REMOTE CONTROL	RC+/RC-:0 ~ 0.8V POWER ON; 4V ~ 10V POWER OFF							
ENVIRONMENT	WORKING TEMP.	-10 ~ +60°C (Refer to output load derating curve)							
	WORKING HUMIDITY	20 ~ 90% RH non-condensing							
	STORAGE TEMP., HUMIDITY	-20 ~ +85°C, 10 ~ 95% RH							
	TEMP. COEFFICIENT	±0.03%/°C (0~50°C)							
	VIBRATION	10 ~ 500Hz, 2G 10min./1cycle, 60min. each along X, Y, Z axes							
SAFETY & EMC (Note 4)	SAFETY STANDARDS	UL60950-1, TUV EN60950-1 Approved							
	WITHSTAND VOLTAGE	I/P-O/P:3KVAC I/P-FG:1.5KVAC O/P-FG:0.5KVAC							
	ISOLATION RESISTANCE	I/P-O/P, I/P-FG, O/P-FG:100M Ohms/500VDC							
	EMI CONDUCTION & RADIATION	Compliance to EN55022 (CISPR22) Class B							
	HARMONIC CURRENT	Compliance to EN61000-3-2,-3							
	EMS IMMUNITY	Compliance to EN61000-4-2,3,4,5,6,8,11; ENV50204, EN55024, Light industry level, criteria A							
OTHERS	MTBF	75.9K hrs min. MIL-HDBK-217F (25°C)							
	DIMENSION	280*127*63.5mm (L*W*H)							
	PACKING	2.4Kg; 6pcs/14.8Kg/1.45CUFT							
NOTE	<ol style="list-style-type: none"> 1. All parameters NOT specially mentioned are measured at 230VAC input, rated load and 25°C of ambient temperature. 2. Ripple & noise are measured at 20MHz of bandwidth by using a 12" twisted pair-wire terminated with a 0.1uf & 47uf parallel capacitor. 3. Tolerance : includes set up tolerance, line regulation and load regulation. 4. The power supply is considered a component which will be installed into a final equipment. The final equipment must be re-confirmed that it still meets EMC directives. 5. Peak current can not exceed 60 sec. 6. Isolated CH3 & CH4 maybe series connected or can be used as positive or negative outputs. 7. Derating may be needed under low input voltages. Please check the derating curve for more details. 								

Mechanical Specification

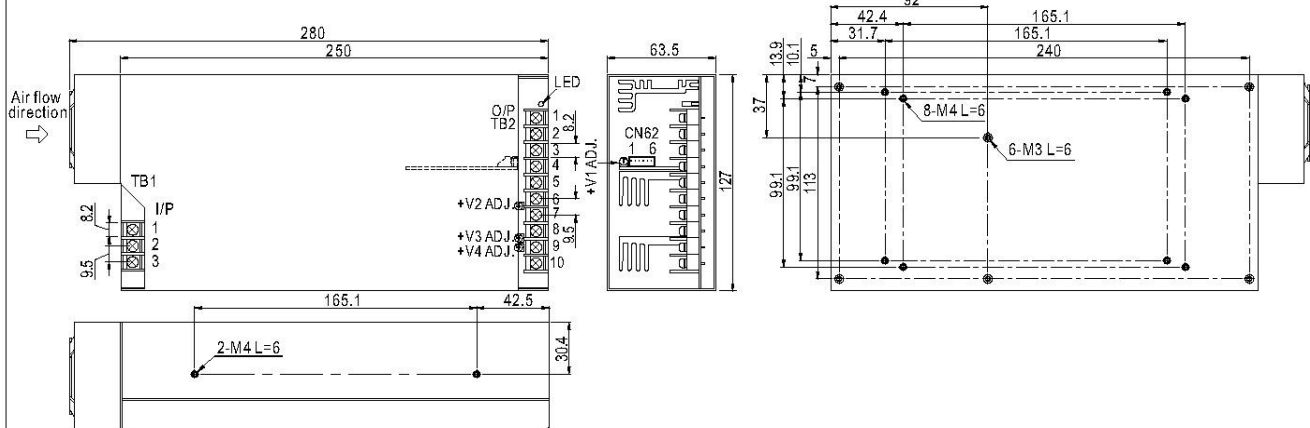

Case No. 927A Unit:mm

AC Input Terminal Pin No. Assignment

Pin No.	Assignment
1	AC/L
2	AC/N
3	FG \perp

DC Output Terminal Pin No. Assignment

Pin No.	Assignment	Pin No.	Assignment
1,2	+V1	8	-V3
3,4,5	COM(V1 and V2)	9	+V4
6	+V2	10	-V4
7	+V3		

CN62 Pin No. Assignment : JST S6B-XH or equivalent

Pin No.	Assignment	Mating Housing	Terminal
1	PF(Power good / Fail signal)	JST XHP or equivalent	JST SXH-001T-P0.8 or equivalent
2	GND		
3	RS-		
4	RS+		
5	RC-		
6	RC+		

Block Diagram

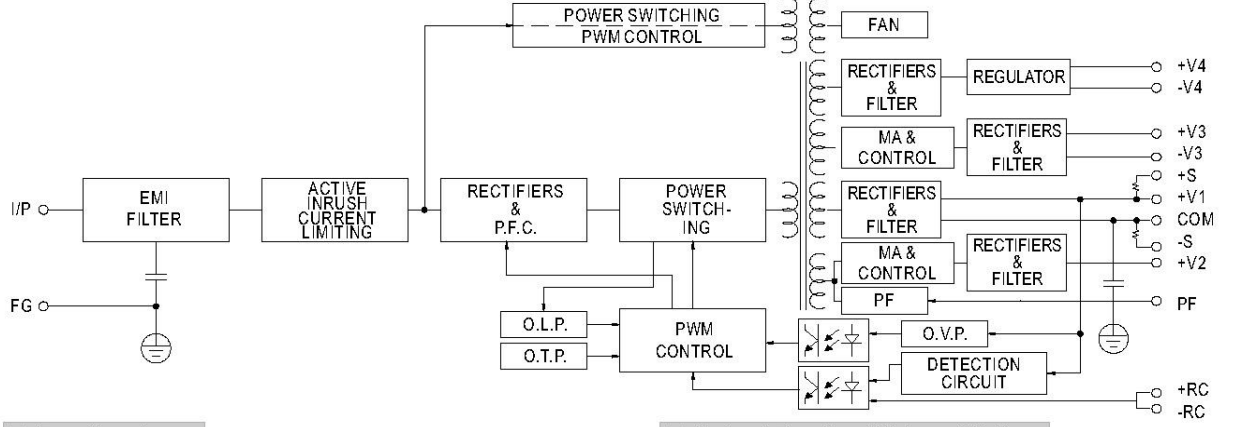

Derating Curve

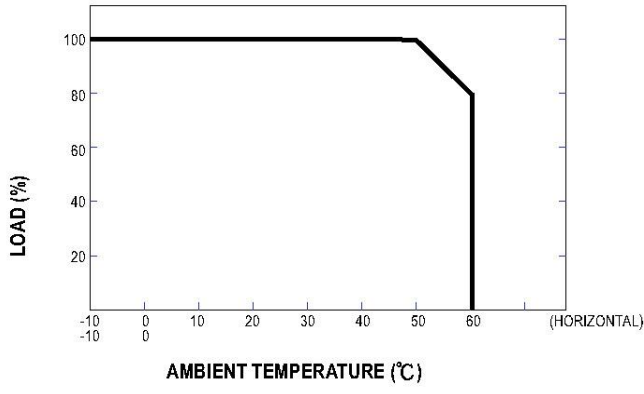

Output Derating VS Input Voltage

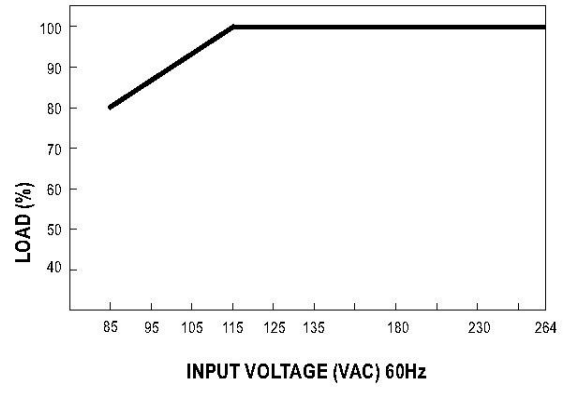

Mechanical Specification

Unit:mm

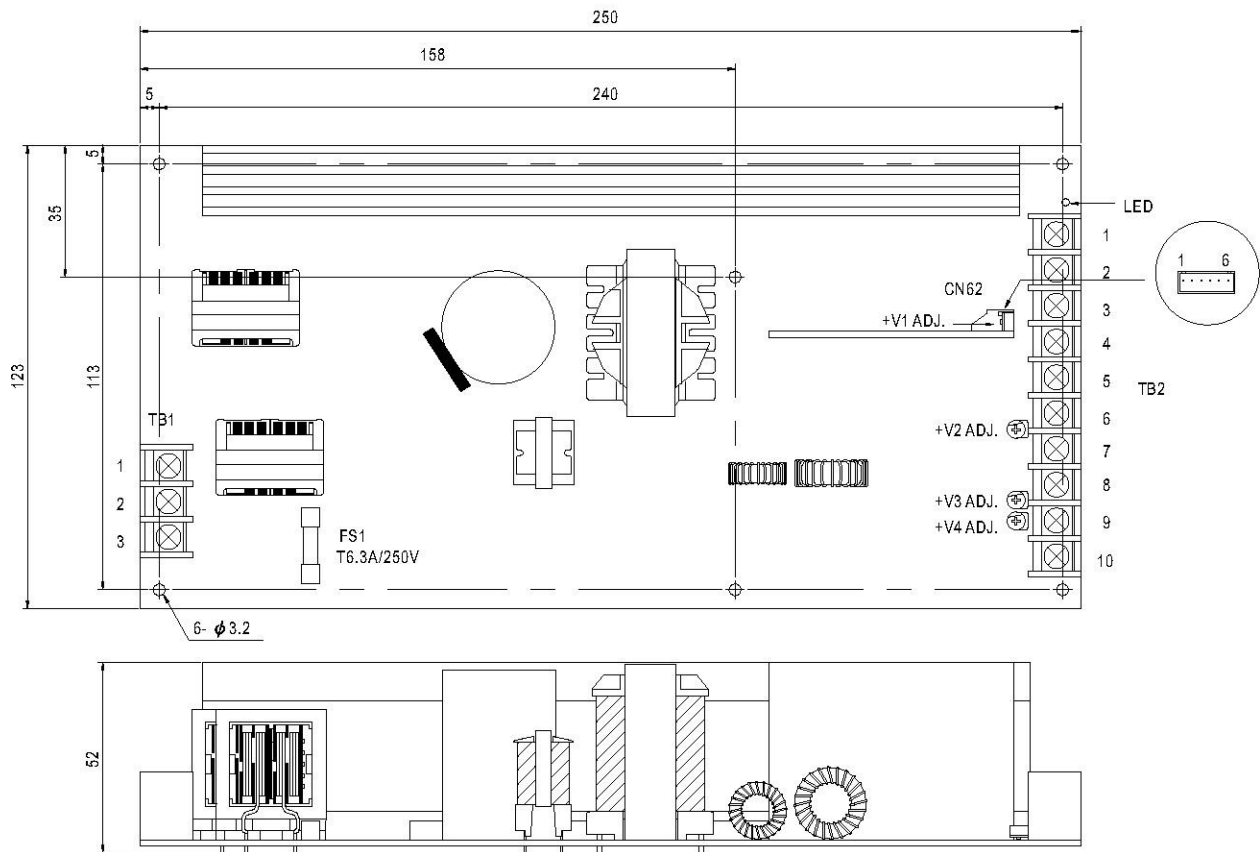

AC Input Terminal Pin No. Assignment

Pin No.	Assignment
1	AC/L
2	AC/N
3	FG \perp

DC Output Terminal Pin No. Assignment

Pin No.	Assignment	Pin No.	Assignment
1,2	+V1	8	-V3
3,4,5	COM(V1 and V2)	9	+V4
6	+V2	10	-V4
7	+V3		

CN62 Pin No. Assignment : JST S6B-XH or equivalent

Pin No.	Assignment	Mating Housing	Terminal
1	PF(Power good / Fail signal)	JST XHP or equivalent	JST SXH-001T-P0.6 or equivalent
2	GND		
3	RS-		
4	RS+		
5	RC-		
6	RC+		

Derating Curve

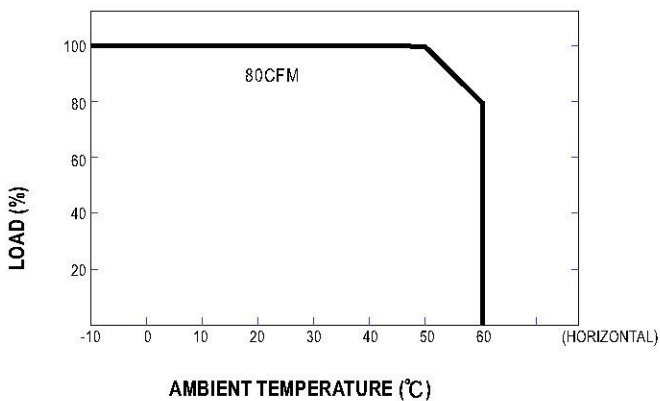

Output Derating VS Input Voltage

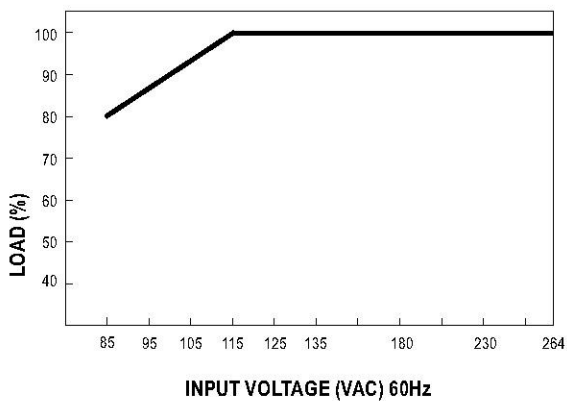

Control terminal instruction manual

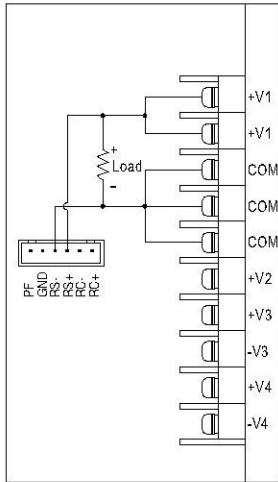

Remote Sensing

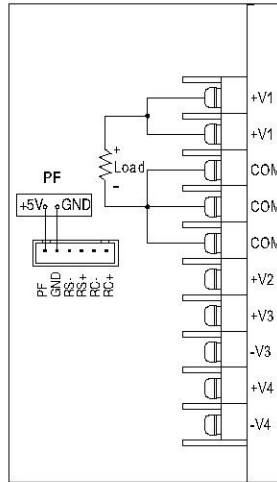

Power Fail Signal

PF Signal is the voltage difference between "GND" and "PF" pin output

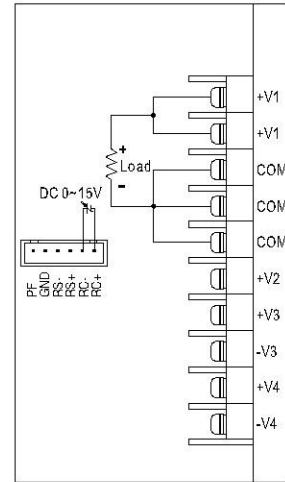

Power Fail Signal

Power ON: When VRC+,RC-=0 ~ 0.8V or Open
Power OFF: When VRC+,RC-=4 ~ 10V

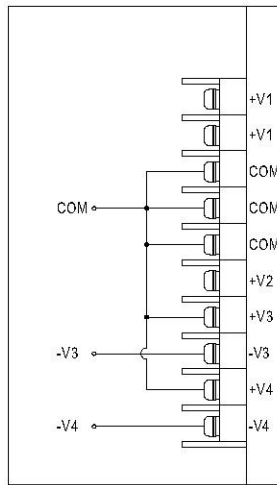

V3, V4 All Negative(-)

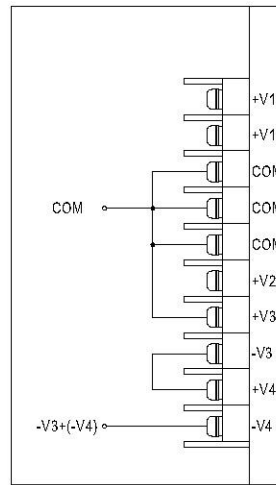

V3 Puls Negative(-)

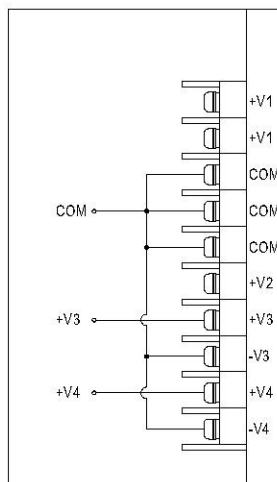

V3, V4 All Positive(+)

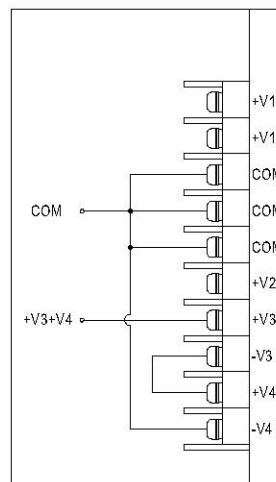

V3 Plus V4 Positive(+)