

# SMARTSLICE

Intelligence, point by point



» Reduce engineering time

» Reduce machine downtime

» Increase your efficiency

Advanced Industrial Automation

**OMRON**

## SmartSlice: Intelligence at I/O level

*In automated production, high availability is absolutely critical to stay efficient. Smart control systems that can help your process stay up are always a worthwhile investment. To help increase your efficiency, Omron is continually improving the communications, flexibility and intelligence of its devices while maintaining the scalability, reliability and backwards compatibility that have become distinguishing features of its range of products.*

Omron's SmartSlice is a modular remote I/O system full of patented, smart features – making it the most intelligent and easy-to-use remote I/O system currently available. SmartSlice will allow you to minimise engineering, troubleshooting and maintenance in your machine, line or plant, resulting in significantly reduced downtime.

### **Cost-efficient operation**

Fast installation, easy configuration, reduced wiring, efficient use of cabinet space and built-in diagnostics all combine to make SmartSlice a key element of Omron's cost-efficient control solution. Furthermore, its high degree of modularity means it can be tailored to meet your specific requirements; you install just the right amount of I/O needed for each application.

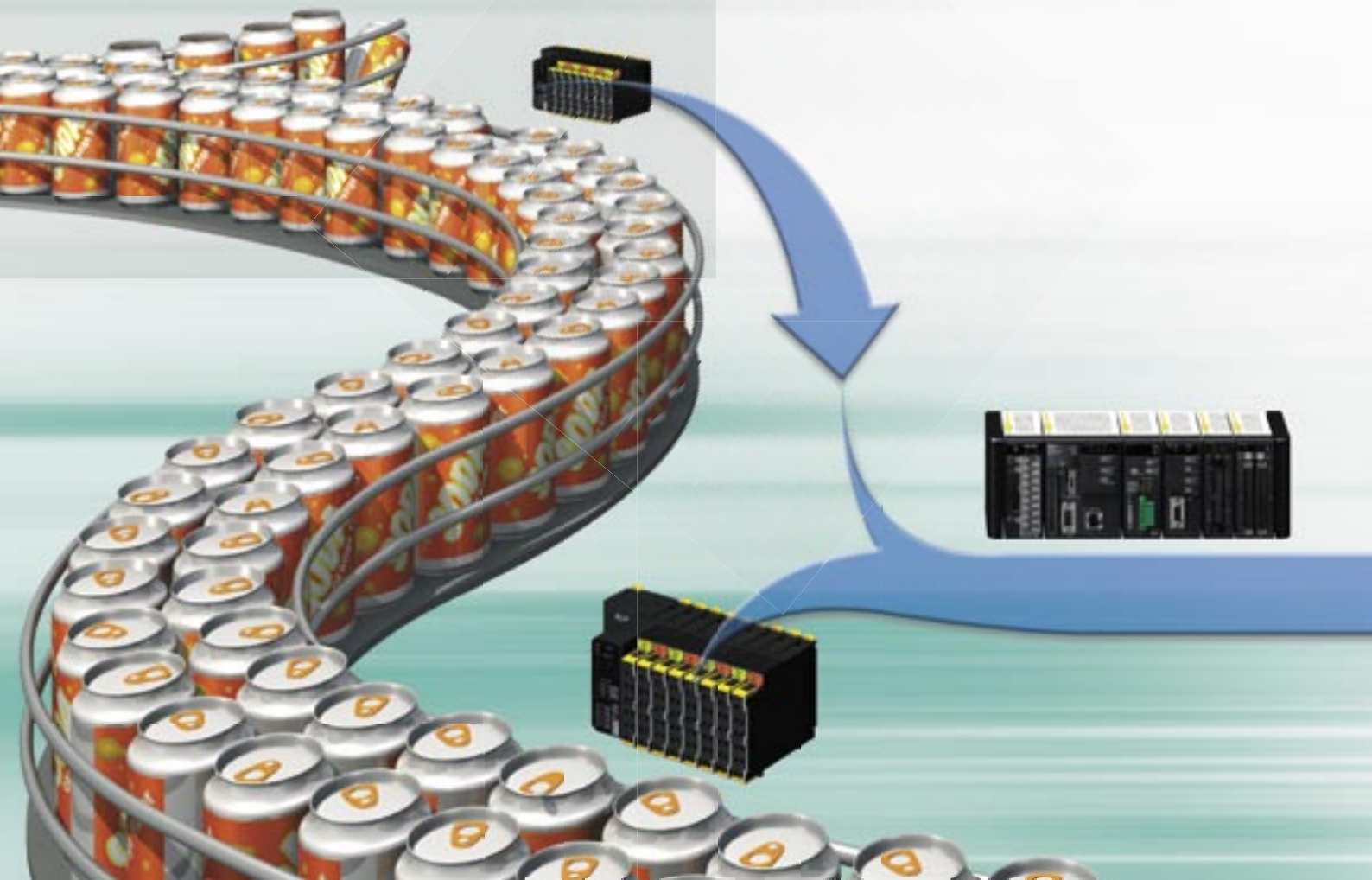



### Transparent communication

SmartSlice connects to any control system via open communication standards such as DeviceNet and Profibus-DP.



Choose DeviceNet for plug-and-work operation on Omron PLC systems; no setup is required. DeviceNet also allows you to tune performance to your needs. With a choice of communication methods – Cyclic, Polled or Change-of-State – each slave can communicate in the way best suited for the application.



Choose Profibus-DP for data rates up to 12 Mbit/s, or long-distance communication up to 1200 m per segment. Fast cyclic data exchange can be combined with DPV1 acyclic messaging for parameter setting. Setup is easy thanks to the latest FDT/DTM technology.

### An integral component of Smart Platform

The SmartSlice remote I/O series was developed as a part of Omron's Smart Platform. Designed to make machine automation easy, Smart Platform provides seamless, drag-and-drop integration of all automation components in your machine. From sensor to controller, from HMI to drive, all devices are accessible through one connection using a single software suite, CX-One. Moreover, built-in distributed intelligence in Omron devices means that you spend less time programming and troubleshooting.

The Smart Platform concept is built around three key elements:

- **One software**  
*for your complete machine*
- **One connection**  
*to reach all your devices*
- **One minute**  
*to achieve what took you hours*

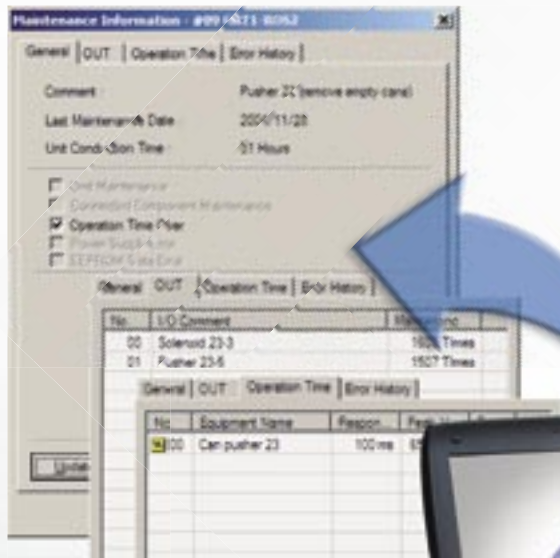

# Smart functions you can rely on

## Maintenance data logging minimises downtime

All SmartSlice I/O units autonomously collect and store the information that will help you plan machine maintenance. Timely detection of reduced performance will minimise unplanned downtime and keep machine performance fast and reliable.

Each unit remembers its last maintenance date: maintenance personnel can check per unit if there have been any replacements or repairs. A descriptive comment can be entered per node, per unit, even per I/O point. This can help you troubleshoot a machine without having to know PLC-internal tag names or programs. All communication that is required passes through multiple network layers without any special PLC programming to gather or store the data.

## Early-warning system prevents breakdowns

Every SmartSlice unit has its own built-in early-warning functions, enabling you to schedule maintenance and prevent breakdowns. Warnings include:



- Supply voltage out of safe range – e.g. due to damaged cable or poor connection



- Preset maintenance interval exceeded – which can be a time interval or a target number of operations, to indicate that an inspection of (electro-)mechanical parts is required



- Maximum allowed delay between two I/O signals is exceeded – to indicate that wear or lack of lubrication is causing a machine to work slower than intended.

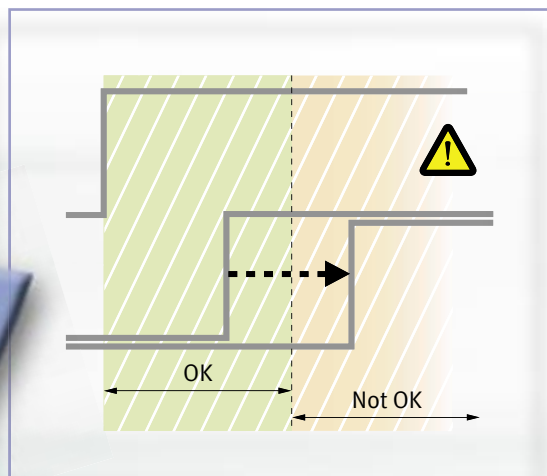
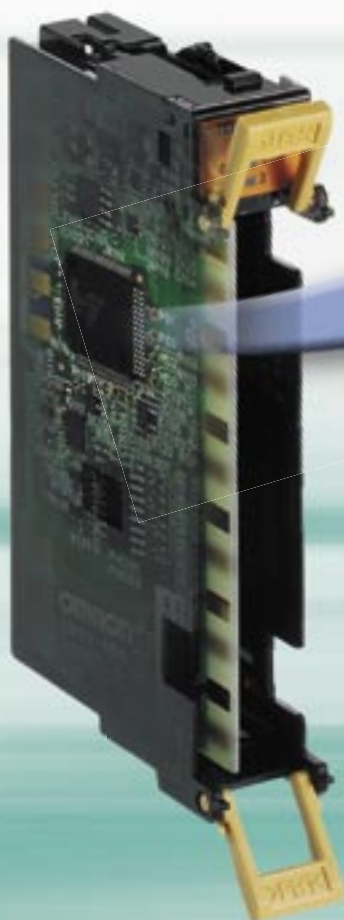

These warnings would be useless if you cannot easily find the underlying cause. Therefore, there are several convenient ways to access the information, with little or no PLC programming:

- Directly from the network maintenance view of CX-One
- By using Smart Active Parts on the NS-series HMIs
- By using predefined Function Blocks in the PLC.

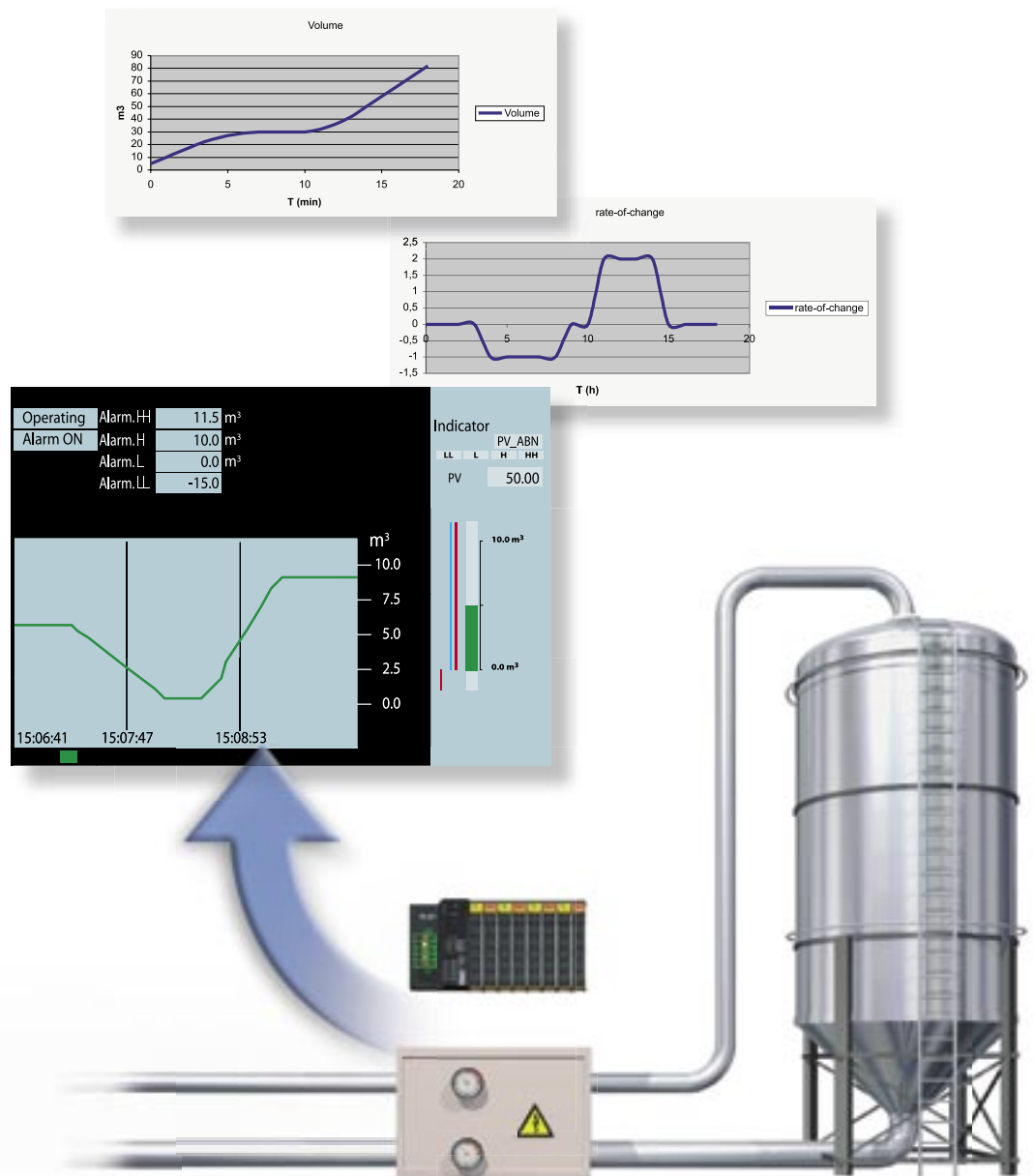

### Smart I/O to reduce your programming effort

SmartSlice analogue I/O units will also help you reduce PLC programming. Many useful functions are already built in, and only require some settings to match your application's characteristics. Some examples:

- Analogue value scaling takes place in the unit. Your PLC program and HMI will only see data in engineering units. No conversion is required, so programs will be shorter and easier to understand.
- Up to four alarm levels can be set per signal. Alarm settings are stored in the SmartSlice unit, and backed up in the interface unit. This allows true hot-swapping, without having to set up the replacement unit.
- Time-based calculations on analogue data can be complex in a PLC. SmartSlice analogue inputs have built-in integration and rate-of-change calculation. Integration calculates a volume based on analogue flow measurement; rate-of-change calculation can be used to warn you that an analogue value is changing faster or slower than expected. This can help detect situations such as leakage, wear, or abnormal load.

# Smart and compact design

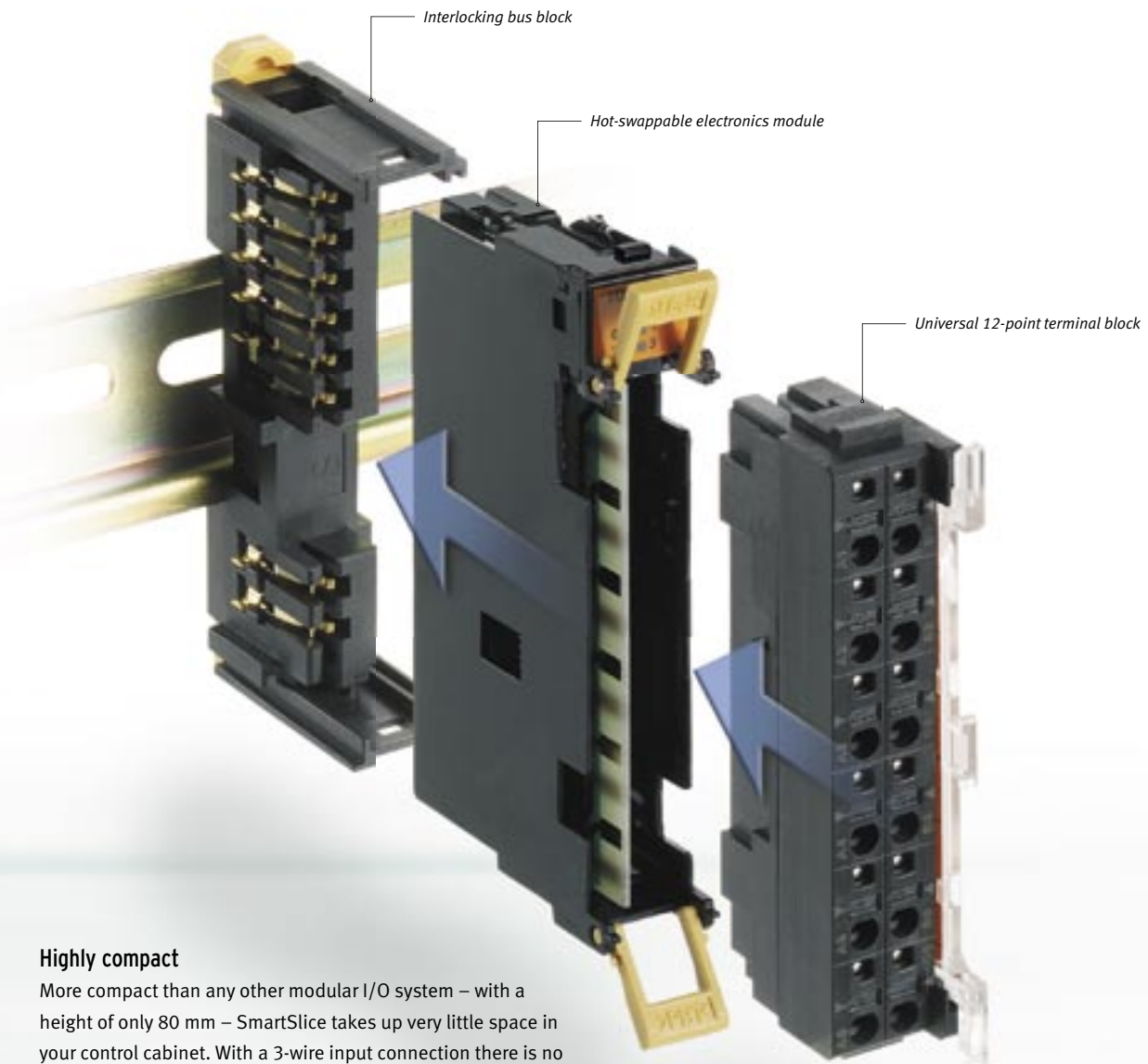

## Highly compact

More compact than any other modular I/O system – with a height of only 80 mm – SmartSlice takes up very little space in your control cabinet. With a 3-wire input connection there is no need for additional power distribution rails; all your field wiring, including sensor power supply, can be directly connected to the units.

## Reliable 3-piece construction

All SmartSlice modules have a 3-piece construction. Interlocking bus blocks build the backplane of the system. The electronics module and removable terminal block plug into the backplane, enabling you to:

- Replace electronic modules while the bus structure and field wiring stay intact. During hot-swapping, all other I/O units continue to operate
- Detach I/O terminals for pre-wiring, maintenance or testing.

All contact surfaces between the electronics module and connectors are gold-plated for 100% reliable connections.

## Easy push-in wiring for quick installation

The SmartSlice terminal blocks provide fast and reliable screwless clamp connections. The 'push-in' design allows toolless insertion of terminated wires. Each individual connection is equipped with a test point to help verification of connections during commissioning and troubleshooting. Each terminal block has a pull-out label holder showing the terminal assignment of the unit.

# The smart way to configure

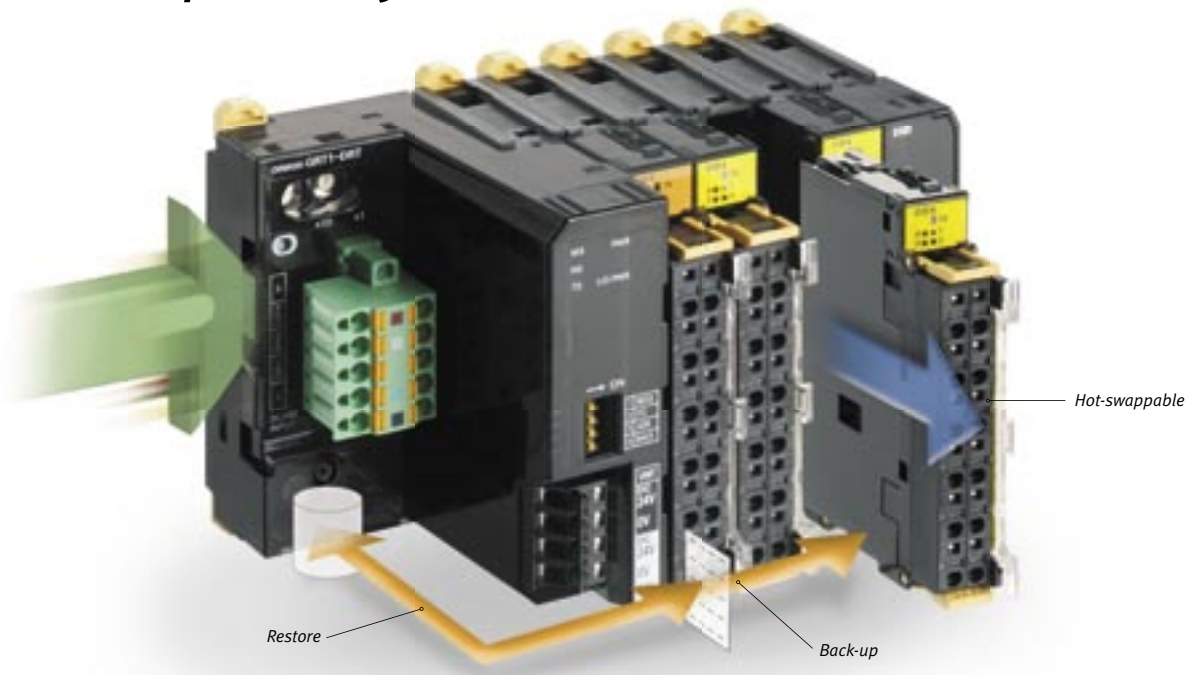

## Fast backup and restore

With all the intelligence and advanced functions in SmartSlice units, backup and recovery of settings are important to support fast maintenance and repair of your machine. These functions are therefore also toolless in SmartSlice. All I/O unit data can be backed up in the bus interface unit at the flick of a switch. Recovery is even simpler; after hot-swapping a unit, all settings are automatically loaded.

## Easy to setup and maintain

When used with Omron DeviceNet Master Units, no configuration is required at all. Simply set a bus address and connect. After startup, the I/O configuration can be stored with

a single switch to make sure any incorrect change of units is detected.

Configuration of the Profibus-DP version is also easier than you expect; thanks to state-of-the-art FDT/DTM\* configuration tools, setting up a SmartSlice station will just take a minute. Integration in existing systems is never a problem; besides FDT/DTM, conventional configuration by GSD file is also supported.

Both DeviceNet and Profibus configuration tools are included in CX-One, Omron's unique all-in-one software suite for configuration, programming and monitoring of a complete automation system, from sensor to drive, from HMI to PLC. Transparent message routing built into Omron devices makes sure that you can reach them all through a single connection. Device status and preventive maintenance data are therefore always accessible.

\* FDT (Field Device Tool) technology standardizes the communication interface between field devices and application software. It is independent from the communication protocol and the software environment of either the device or the host system. A DTM (Device Type Manager) is a plug-in using this standard interface to add a device-specific user interface and communication channel to any FDT-based software tool. The combination FDT/DTM allows any device to be accessed from any host system through any protocol.



# SmartSlice

## The smartest modular I/O system

OMRON's new SmartSlice I/O system is compact, intelligent and easy. When used with OMRON's CS1/CJ1 DeviceNet master units, no configuration tool is required. By using built-in functions such as pre-scaling, totalising, differentiation and alarming in analog I/O units, PLC programming can be minimised. Preventive maintenance data can be accessed using CX-Integrator software, standard PLC function blocks or NS-series Smart Active Parts.

- Most compact in the market (84 mm high)
- Easy set-up, backup and restore functions
- Diagnostics and preventive maintenance data at I/O level
- Detachable terminal blocks allow hot-swapping without re-wiring
- 3-wire connection with 'push-in' technology, no screwdriver required

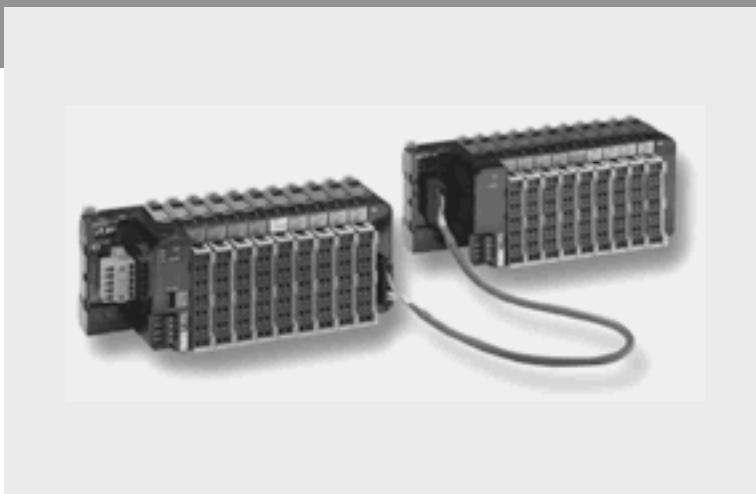

## System Configuration

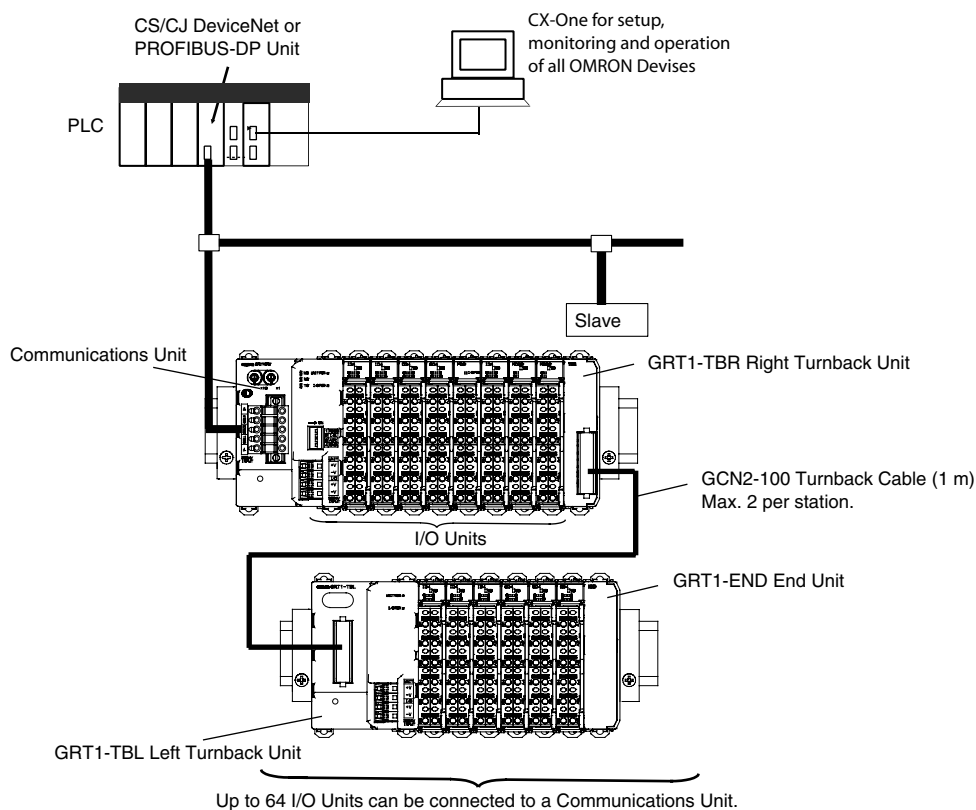

Specifications

General Specifications

Common SmartSlice Specifications	
Unit power supply voltage	24 V DC (20.4 to 26.4 V DC)
I/O power supply voltage	24 V DC (20.4 to 26.4 V DC)
I/O connection	Screwless push-in technology
Noise immunity	Conforms to IEC61000-4-4, 2.0 kV (power supply line)
Vibration resistance	10 to 60 Hz: 0.7 mm double amplitude 60 to 150 Hz: 50 m/s <sup>2</sup>
Shock resistance	150 m/s <sup>2</sup> , 3 times in each direction
Dielectric strength	500 VAC (between isolated circuits)
Insulation resistance	20 MΩ min. (between isolated circuits)
Ambient operating temperature	-10 to 55°C (with no icing or condensation)
Ambient operating humidity	25% to 85%
Operating environment	No corrosive gases
Ambient storage temperature	-25 to 65°C (with no icing or condensation)
Mounting	35 mm DIN rail

Communication Units

Model name	GRT1-DRT	GRT1-PRT
Network Specification	DeviceNet	PROFIBUS-DPV1
Network connector	Open-stype DeviceNet connector, dual screwless push-in dual connections.	9-pin D-Sub
Network power supply	11 to 25 V DC, 22 mA	Internal
Number of I/O points	1,024 inputs and outputs max. (128 bytes each)	
Number of connectable Units	64 SmartSlice I/O Units max.	
I/O power supply	24 V DC, 4 A max.	
Status flags	1 word for Communications Unit status flags	
Parameter backup and restore	up to 2 KB of data per Unit.	

I/O Units

Model name	GRT1-ID4	GRT1-ID4-1
Signal type	DC input (for sinking outputs)	DC input (for sourcing outputs)
Number of points	4 inputs (3-wire connection)	
ON voltage	15 V DC min.	
ON current	6 mA max./point (at 24 V DC)	
OFF voltage	5 V DC max.	
OFF current	1 mA max.	
ON delay / OFF delay	1.5 ms max.	

Model name	GRT1-OD4	GRT1-OD4-1	GRT1-ROS2
Signal type	Transistor output (sinking, NPN)	Transistor output (PNP, sourcing)	Relay output (normally open)
Number of points	4 outputs (2-wire connection)		2 outputs (with 2 terminals per connection)
Rated voltage	24 V DC (20.4 to 26.4 V DC)		250 V AC / 24 V DC
Rated output current	500 mA max./point		2 A (min. 1 mA @ 5 V DC)
Residual voltage	1.2 V DC max. (at 500 mA)		-
Leakage current	0.1 mA max.		-
ON delay / Off delay	0.5 / 1.5 ms max.		15 ms max.
Mechanical life expectancy	-		20,000,000 times min.
Electrical life expectancy	-		100,000 times min.

Model name	GRT-AD2	GRT1-DA2V	GRT1-DA2C
Signal type	Analog Input: 0-20mA, 4-20mA, ±10V, 0-10V, 0-5V, 1-5V	Analog Output: ±10V, 0-10V, 0-5V, 1-5V	Analog Output: 0-20mA, 4-20mA,
Number of points	2 inputs	2 outputs	
Resolution	1/6000 full scale		
Conversion time	2ms / 2points		

Model name	GRT1-CP1-L
Counter input	A/B/Z incremental encoder, or pulse/direction/reset
Counter signal type	24 V DC, or RS422 Line driver levels
Max. frequency	100 kHz
Counter range	32 bit double signed integer
Comparison values	2 independent ranges
Control Input	IN0, DC input (for sourcing outputs)
Control Input functions	Capture, Preset, Reset, Z enable
Control Outputs	OUT0, OUT1, Transistor Output (sourcing)
Control Output functions	Range comparison, manual override
Additional functions	On-the-fly reconfiguration, Frequency measurement

Connections

GRT1-ID4

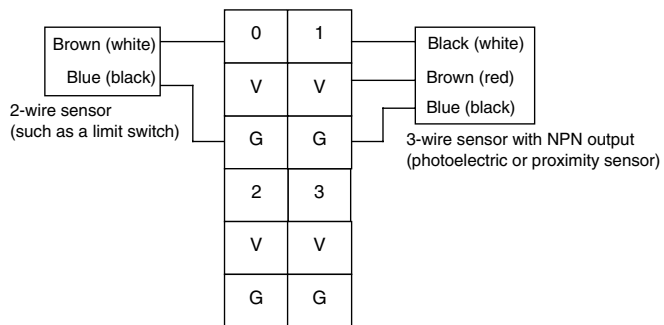

GRT1-ID4-1

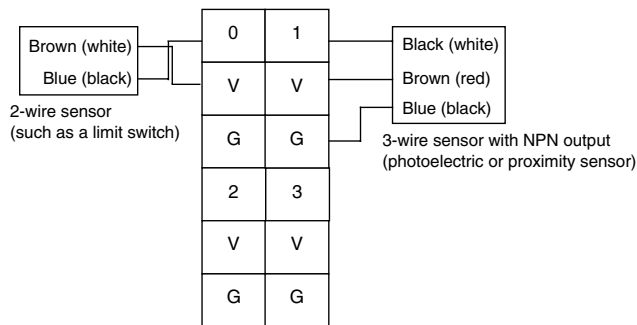

GRT1-OD4

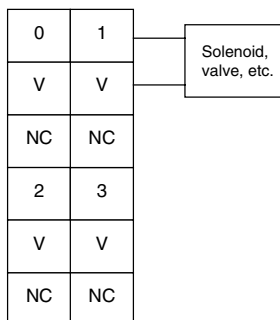

GRT1-OD4-1

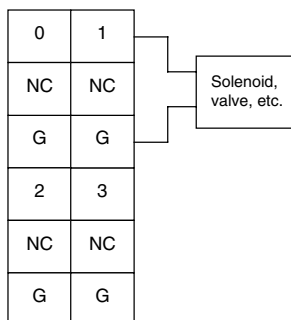

GRT1-ROS2

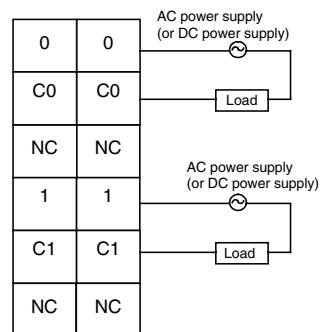

GRT-AD2

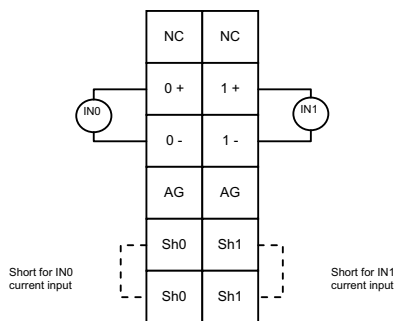

GRT1-DA2V

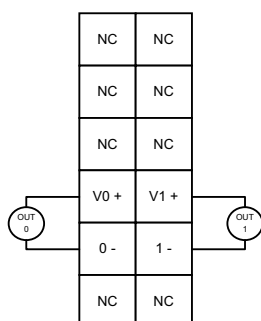

GRT1-DA2C

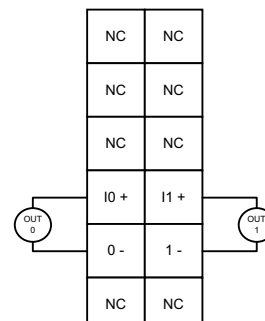



## Ordering Information

### Interface Units

Function	Specification	Model code
DeviceNet Interface Unit	For up to 64 I/O units	GRT1-DRT
Profibus-DP Interface Unit	For up to 64 I/O units	GRT1-PRT

### I/O units

Function	Specification	Model code
4 NPN inputs	24 V DC, 7 mA, 3-wire connection	GRT1-ID4
4 PNP inputs	24 V DC, 7 mA, 3-wire connection	GRT1-ID4-1
4 NPN outputs	24 V DC, 500 mA, 2-wire connection	GRT1-OD4
4 PNP outputs	24 V DC, 500 mA, 2-wire connection	GRT1-OD4-1
2 relay outputs	240 V AC, 2A, normally-open contacts	GRT1-ROS2
100 kHz Counter / Positioner unit	A/B/Z encoder input (line driver or 24 V selectable) + 1 control input + 2 outputs (PNP-type)	GRT1-CP1-L*
2 Thermocouple inputs	Type R, S, K, J, T, L, B, U, N, W, E, and PLII selectable	GRT1-TS2T*
2 Pt100 inputs	Pt100 / JPt100 selectable	GRT1-TS2P*
2 analogue inputs, current/voltage	±10 V, 0-10 V, 0-5 V, 1-5 V, 0-20 mA, 4-20 mA	GRT1-AD2
2 analogue outputs, voltage	± 10 V, 0-10 V, 0-5 V, 1-5 V	GRT1-DA2V
2 analogue outputs, current	0-20 mA, 4-20 mA	GRT1-DA2C

### Expansion

Function	Model code
I/O power feed unit, separates power supply between groups of I/O units	GRT1-PD2
Turnback Unit, right-hand side	GRT1-TBR
Turnback Unit, left-hand side	GRT1-TBL
Turnback cable, one meter	GCN1-100
End plate, one unit required per bus interface	GRT1-END

### PLC Master Units

Function	Model code
DeviceNet Master Unit for CS1-series PLCs	CS1W-DRM21-V1
DeviceNet Master Unit for CJ1-series PLCs	CJ1W-DRM21
PROFIBUS-DP Master Unit for CS1-series PLCs	CS1W-PRM21
PROFIBUS-DP Master Unit for CJ1-series PLCs	CJ1W-PRM21

### Software

Function	Model code
CX-One, Omron's integrated software for programming and configuration of all control system components, including PLCs, remote I/O, HMI, servo drives, inverters, temperature controllers and advanced sensors.	CX-ONE-AL□□ C-E □□ = number of licenses (01, 03, 10)

Cat. No. P15E-EN-01

In the interest of product improvement, specifications are subject to change without notice.

---

**OMRON EUROPE B.V.**

Wegalaan 67-69,  
NL-2132 JD, Hoofddorp,  
The Netherlands  
Phone: +31 23 568 13 00  
Fax: +31 23 568 13 88  
[www.eu.omron.com](http://www.eu.omron.com)

**OMRON EUROPE B.V.** Wegalaan 67-69, NL-2132 JD, Hoofddorp, The Netherlands. Tel: +31 (0) 23 568 13 00 Fax: +31 (0) 23 568 13 88 [www.omron-industrial.com](http://www.omron-industrial.com)

**Austria**

Tel: +43 (0) 1 80 19 00  
[www.omron.at](http://www.omron.at)

**Belgium**

Tel: +32 (0) 2 466 24 80  
[www.omron.be](http://www.omron.be)

**Czech Republic**

Tel: +420 234 602 602  
[www.omron.cz](http://www.omron.cz)

**Denmark**

Tel: +45 43 44 00 11  
[www.omron.dk](http://www.omron.dk)

**Finland**

Tel: +358 (0) 207 464 200  
[www.omron.fi](http://www.omron.fi)

**France**

Tel: +33 (0) 1 56 63 70 00  
[www.omron.fr](http://www.omron.fr)

**Germany**

Tel: +49 (0) 2173 680 00  
[www.omron.de](http://www.omron.de)

**Hungary**

Tel: +36 (0) 1 399 30 50  
[www.omron.hu](http://www.omron.hu)

**Italy**

Tel: +39 02 32 68 777  
[www.omron.it](http://www.omron.it)

**Middle East & Africa**

Tel: +31 (0) 23 568 11 00  
[www.omron-industrial.com](http://www.omron-industrial.com)

**Netherlands**

Tel: +31 (0) 23 568 11 00  
[www.omron.nl](http://www.omron.nl)

**Norway**

Tel: +47 (0) 22 65 75 00  
[www.omron.no](http://www.omron.no)

**Poland**

Tel: +48 (0) 22 645 78 60  
[www.omron.pl](http://www.omron.pl)

**Portugal**

Tel: +351 21 942 94 00  
[www.omron.pt](http://www.omron.pt)

**Russia**

Tel: +7 495 745 26 64  
[www.omron.ru](http://www.omron.ru)

**Spain**

Tel: +34 913 777 900  
[www.omron.es](http://www.omron.es)

**Sweden**

Tel: +46 (0) 8 632 35 00  
[www.omron.se](http://www.omron.se)

**Switzerland**

Tel: +41 (0) 41 748 13 13  
[www.omron.ch](http://www.omron.ch)

**Turkey**

Tel: +90 (0) 216 474 00 40  
[www.omron.com.tr](http://www.omron.com.tr)

**United Kingdom**

Tel: +44 (0) 870 752 08 61  
[www.omron.co.uk](http://www.omron.co.uk)

**More Omron representatives**

[www.omron-industrial.com](http://www.omron-industrial.com)

*Authorised Distributor:*

**Control Systems**

• Programmable logic controllers • Human-machine interfaces • Remote I/O

**Motion & Drives**

• Motion controllers • Servo systems • Inverters

**Control Components**

• Temperature controllers • Power supplies • Timers • Counters • Programmable relays  
• Digital panel indicators • Electromechanical relays • Monitoring products • Solid-state relays  
• Limit switches • Pushbutton switches • Low voltage switch gear

**Sensing & Safety**

• Photoelectric sensors • Inductive sensors • Capacitive & pressure sensors • Cable connectors  
• Displacement & width-measuring sensors • Vision systems • Safety networks • Safety sensors  
• Safety units/relay units • Safety door/guard lock switches