

⚠ Read First

⚠ Safety Information

Understand and follow operating instructions carefully. Use the meter only as specified in this manual; otherwise, the protection provided by the meter may be impaired.

⚠ WARNING

This Identifies hazardous conditions and actions that could cause **BODILY HARM** or **DEATH**











- When using test leads, keep your fingers behind the finger guards.
- Always use proper test probes for measurements.
- Discharge all high-voltage capacitors before testing.
- Do not use meter around explosive gas or vapor.
- To reduce the risk of fire or electric shock do not expose this product to rain or moisture.
- Do not touch any circuits or parts of circuits if there may be 30VAC rms or 30 VDC on them.
- Be careful of the test probes, which are sharp and dangerous.

⚠ CAUTION

This identifies conditions and actions that could **DAMAGE** the meter or equipment under test.

- Never connect a source of voltage to the meter. That may be damage the meter.
- Discharge all capacitors before testing.
- Do not expose meter to extremes in temperature or high humidity.
- Do not drop the meter. That maybe damage the meter or cause out of specification.
- Never use unspecified adaptor to charge meter.
- Do not continue to charge more than 8 hours to prevent the battery damage.

Symbols as marked on the Meter and Instruction manual

	Risk of electric shock
	See instruction manual
	AC measurement
	DC measurement
	Battery
	Fuse
	Earth
	Equipment protected by double or reinforced insulation
	Conforms to EU directives
	Do not discard this product or throw away.

Maintenance

Do not attempt to repair this Meter.
It contains no user serviceable parts. Repair or servicing should only be performed by qualified personnel.

Cleaning

Periodically wipe the case with a dry cloth and detergent.
Do not use abrasives or solvents.

Meter Description

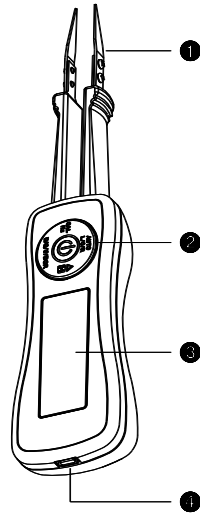

1. Test probes
2. Push buttons for features
3. LCD display: 20,000 counts
4. Mini USB plug for charge & connect to PC

Assembly

1. USB cable
2. AC adaptor (for 1707)
3. L Type Test probes & special screws x 4 (for 1707)
4. Software CD (for 1707)
5. Contact Holder

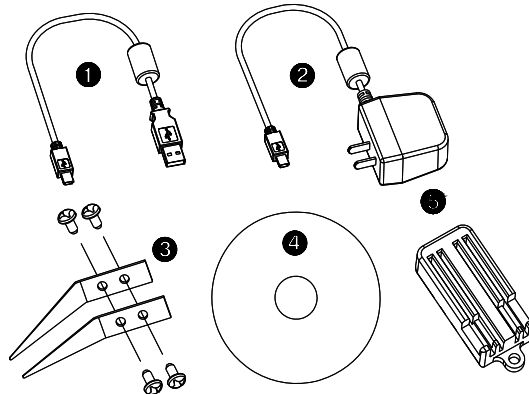

Measuring Principle

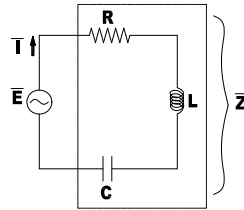

$$\bar{E} = R + j(X_L - X_C)$$

$$\bar{Z} = \sqrt{R^2 + (X_L - X_C)^2} \leq \tan^{-1} \left(\frac{X_L - X_C}{R} \right)$$

$$X_L = 2\pi fL = \omega L$$

$$X_C = \frac{1}{2\pi fC} = \frac{1}{\omega C}$$

$$\theta = \tan^{-1} \left(\frac{X_L - X_C}{R} \right)$$

$$Q = \frac{1}{D} = \tan \theta$$

Series Measuring



Parallel Measuring

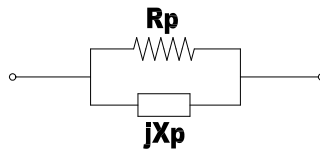

Phase Drawing

The phasor is a constant complex number, usually expressed in exponential form, representing the complex amplitude (magnitude and phase) of a sinusoidal function of time.

When θ (phase) $> 0^\circ$

Then Z (impedance) is
Capacitive reactance

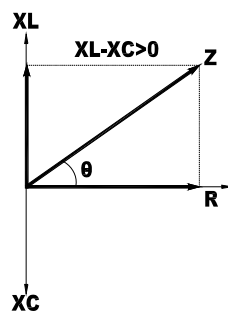

When θ (phase) $< 0^\circ$

Then Z (impedance) is
Inductive reactance

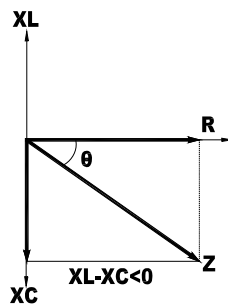

When θ (phase) $= 0^\circ$

Then Z (impedance) is
Resistance

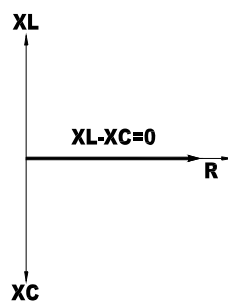

Making Basic Measurements

Preparation and Caution Before Measurement
Observe the rules of **⚠WARNING** and **⚠CAUTION**

Discharge the DUT (Device Under Test) before connecting the test probes. The figures on the following pages show how to make basic measurements.

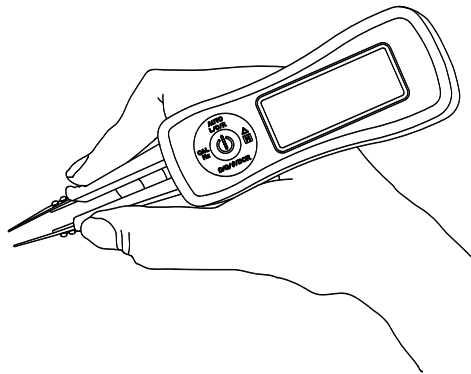

Power On/Off

Press the central power button to turn on. Press and hold the power button > 2 sec to turn off.

Auto Power Off

If there is no any action in the meter, then the meter will automatically turn off to save the power of battery. The default APO time is 10 minutes.

Backlight

When the meter is turned on, the backlight will be turned on automatically. Press the central power button to turn on/off the backlight.

Measuring L/C/R

The auto test mode is the default mode when the meter is turned on. When the meter in auto test mode, it will automatically detect the DUT and show the suitable result on the display.

- In auto test mode, press the AUTO L/C/R button to enter manual test mode.
- In manual test mode, press the AUTO L/C/R button to select measuring function.
- To return the auto test mode, press and hold the AUTO L/C/R button > 2 sec.

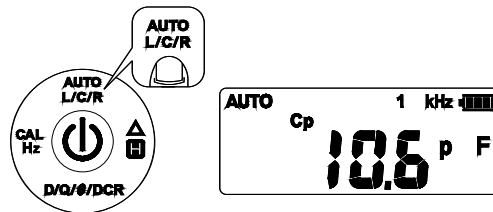

Measuring D/Q/θ/DCR

The meter can measure D (dissipation factor), Q (quality factor), θ (phase) and DCR (DC resistance) on the DUT.

- Press the D/Q/θ/DCR button to enter D/Q/θ/DCR test mode.
- In D/Q/θ/DCR test mode, press the D/Q/θ/DCR button to select measuring function.

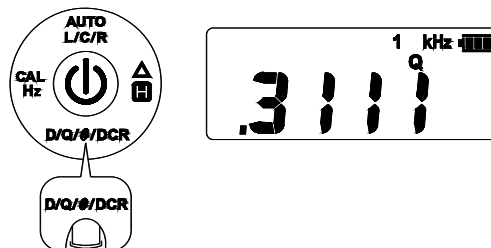

Select Test Frequency

The default test frequency is 1kHz when the meter is turned on. Press the Cal/Hz button to select the test frequency.

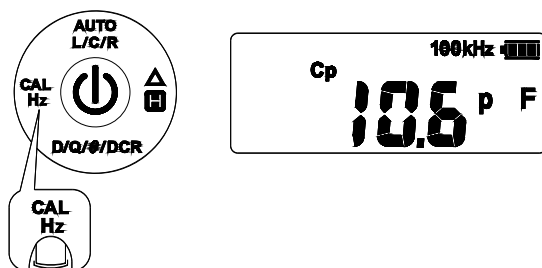

Open/Short Calibration

In order to achieve the best measuring result, the calibration has to be done before measuring the DUT. To calibrate the meter, press and hold the Cal/Hz button > 2 sec.

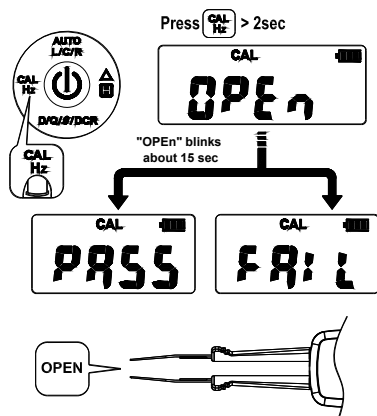

When "OPEN" appears on the display, make the test probes open, and press the Cal/Hz button to start open calibration. During open calibration, the "OPEN" blinks on the display. About 15 seconds later, the result of the open calibration appears on the display. If the result shows "PASS", press the Cal/Hz button to next step. If the result shows "FAIL", press the Cal/Hz button to exit calibration mode.

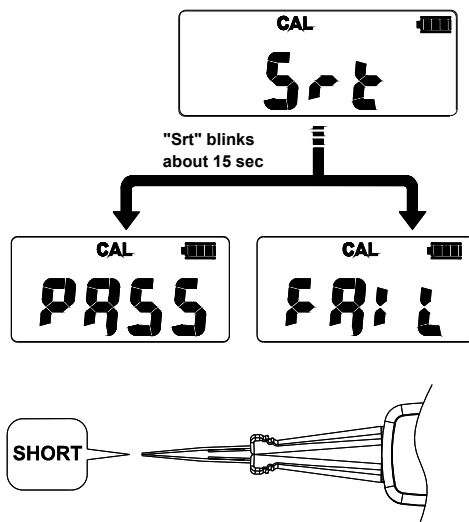

When "Srt" appears on the display, make the test probes short closely, and press the Cal/Hz button to start short calibration. During short calibration, the "Srt" blinks on the display. About 15 seconds later, the result of the short calibration appears on the display. If the result shows "PASS", press the Cal/Hz button to finish calibration. If the result shows "FAIL", press the Cal/Hz button to exit calibration mode.

Hold

Press the Δ /H button to enter the hold mode. The meter holds the last reading and shows the indication "H" on the display. Press the Δ /H button again to exit the hold mode.

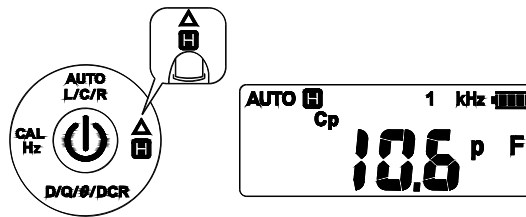

Relative Δ

Press and hold the Δ /H button > 2 sec to start the relative mode. The meter stores the last reading as reference and shows the indication " Δ " on the display. In this mode, the meter deducts the reference from each reading, and shows the result on the display. If the result is negative, the "Er" appears on the display. Press the Δ /H button > 2 sec to exit this mode.

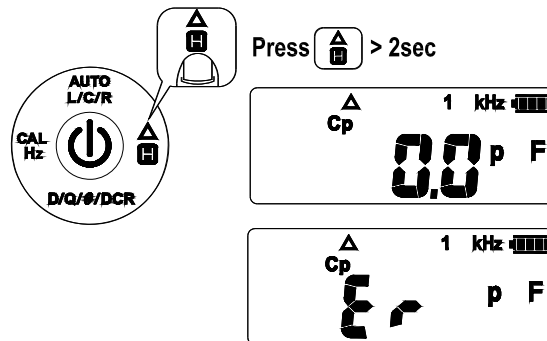

Charge

There is a Li-ion battery as power source in the meter. When the battery indicator shows low battery, charge the meter as soon as possible. When battery charge complete, the battery indicator will show full level on the display.

- Always use the typical mini USB plug adaptor to charge.
- Do not continue to charge more than 8 hours to prevent the battery damage.

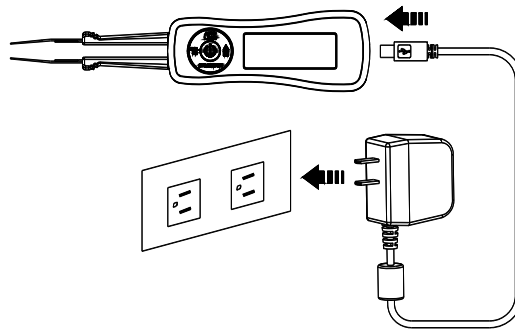

Connect to PC

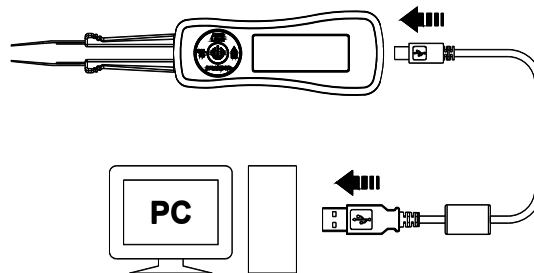

The meter can connect to PC by USB cable. Follow the below steps to setup.

1. Connect PC and meter by USB cable.
2. Turn on the meter power.
3. Insert the software CD to CD-ROM of PC.
4. Install the driver and software.
5. Start the software and communicate with meter.

General Specifications

Display : 20,000 counts

Polarity Indication :

Automatic, positive implied, negative indicated.

Over Range Indication : OL

Measuring Rate : 2.5 samples per second

Internal Power Requirements : 3.7V / 400mAh Li-ion Battery

External Power Requirements : USB plug or AC Adapter

Battery Life : 20 hours typical (no backlight)

Battery Charge Cycle : 2 hours typical

Low Battery Voltage : 3.8V

Auto Power Off : Default 10 minutes.

Operating Ambient :

0°C to 30°C (< 85% RH),

30°C to 40°C (< 75% RH),

40°C to 45°C (< 45% RH)

Storage Temperature :

-20°C to 60°C, 0% RH to 80% RH (batteries not fitted)

Temperature Coefficient :

0.1 x (Specified Accuracy) / °C, < 18°C or > 28°C

Operating Altitude : 6561.7ft (2000m)

Calibration Cycle : 1 time per year

Weight : 70g

Dimensions (H x W x L) : 23 x 38 x 168 (mm)

EMC : EN 61326-1, EN 61326-2, EN 61000-4

Pollution Degree : 2

Shock Vibration : MIL-PRF-28800F for a class 2 instrument

Indoor Use.

Electrical Specifications

- Accuracy is \pm (% of reading + LSD)
- Ambient temperature: $23^{\circ}\text{C} \pm 5^{\circ}\text{C}$ (< 80% RH)

Test Frequency

Model	Frequency	Accuracy
705/707	100Hz 120Hz 1kHz 10kHz	$\pm 0.2\%$
707	100kHz	

Test Signal

AC Signal Level: 600mVrms

AC Signal Accuracy: $\pm 20\%$

DC Bias Level: 800mV

DC Bias Accuracy: $\pm 10\%$

When measuring by basic accuracy that following conditions must be met:

- Ambient temperature: $23^{\circ}\text{C} \pm 5^{\circ}\text{C}$ (< 80% RH)
- Open and short calibration have been performed.
- $D \leq 0.1$ for C, L measurements; $Q \leq 0.1$ for R measurements.
- Do not measure when charge by AC adaptor. It may cause the reading rolling.
- See the operation manual for additional conditions.

D & Q

Definition: $Q = 1/D = \tan\theta$

Range: 2.000 to 2000

Minimum Resolution: 0.001

Accuracy: $\pm (0.5\% + 5) \times (1+D)$, when $D < 1$ or $Q > 1$

θ

Definition: $\theta = \tan^{-1}Q$

Range: -90.0° to 90.0°

Minimum Resolution: 0.1°

Accuracy: $\pm (0.5\% + 5)$

Inductance

Range	100Hz 120Hz	1kHz	10kHz	100kHz
20.000uH	N/A	N/A	N/A	0.5% + 30 ^[1]
200.00uH	N/A	N/A	0.5% + 30 ^[1]	0.5% + 5
2000.0uH	N/A	0.5% + 30 ^[1]	0.5% + 5	0.5% + 5
20.000mH	0.5% + 30 ^[1]	0.5% + 5	0.5% + 5	1.0% + 5
200.00mH	0.5% + 5	0.5% + 5	0.5% + 5	N/A
2000.0mH	0.5% + 5	0.5% + 5	1.0% + 5 ^[2]	N/A

[1] Accuracy is specified after subtract of the offset inductance.
 [2] < 50dgt rolling.
 [3] If D > 0.1, the accuracy should be multiplied by $\sqrt{1 + D^2}$.

Capacitance

Range	100Hz 120Hz	1kHz	10kHz	100kHz
200.00pF	N/A	N/A	2.0% + 1pF ^[1]	2.0% + 1pF ^{[1][2]}
2000.0pF	0.5% + 8 ^[1]	0.5% + 8 ^[1]	0.5% + 8 ^[1]	0.5% + 8 ^[1]
20.000nF	0.5% + 5	0.5% + 5	0.5% + 5	0.5% + 5
200.00nF	0.5% + 5	0.5% + 5	0.5% + 5	1.0% + 5
2000.0nF	0.5% + 5	0.5% + 5	1.0% + 5	N/A
20.000uF	0.5% + 5	1.0% + 5	N/A	N/A
200.00uF	1.0% + 5	N/A	N/A	N/A

[1] Accuracy is specified after subtract of the stray capacitances for test leads.
 [2] < 50dgt rolling.
 [3] If D > 0.1, the accuracy should be multiplied by $\sqrt{1 + D^2}$.

Resistance

Range	100Hz 120Hz	1kHz	10kHz	100kHz
20.000Ω	N/A	0.5% + 50 ^[1]	0.5% + 50 ^[1]	0.5% + 50 ^[1]
200.00Ω	0.5% + 8 ^[1]	0.5% + 8 ^[1]	0.5% + 8 ^[1]	0.5% + 8 ^[1]
2.0000kΩ	0.5% + 5	0.5% + 5	0.5% + 5	0.5% + 5
20.000kΩ	0.5% + 5	0.5% + 5	0.5% + 5	1.0% + 5 ^[2]
200.00kΩ	0.5% + 5	0.5% + 5	1.0% + 5 ^[2]	N/A
2.0000MΩ	0.5% + 5	1.0% + 5 ^[2]	N/A	N/A
20.000MΩ	1.0% + 5 ^[2]	N/A	N/A	N/A

[1] Accuracy is specified after subtract of the offset resistance.
 [2] < 50dgt rolling.
 [3] If Q > 0.1, the accuracy should be multiplied by $\sqrt{1+Q^2}$.

DC Resistance

Range	Resolution	Accuracy
200.00Ω	10mΩ	0.5% + 8 ^[1]
2.0000kΩ	100mΩ	0.5% + 5
20.000kΩ	1Ω	0.5% + 5
200.00kΩ	10Ω	0.5% + 5
2.0000MΩ	100Ω	0.5% + 5
20.000MΩ	1kΩ	1.0% + 5
200.00MΩ	10kΩ	2.0% + 5 ^[2]

[1] Accuracy is specified after subtract of the offset resistance.
 [2] < 50dgt rolling.

Limited Warranty

This meter is warranted to the original purchaser against defects in material and workmanship for 3 years from the date of purchase. During this warranty period, RS Components will, at its option, replace or repair the defective unit, subject to verification of the defect or malfunction.

This warranty does not cover fuses, disposable batteries, or damage from abuse, neglect, accident, unauthorized repair, alteration, contamination, or abnormal conditions of operation or handling.

Any implied warranties arising out of the sale of this product, including but not limited to implied warranties of merchantability and fitness for a particular purpose, are limited to the above. RS Components shall not be liable for loss of use of the instrument or other incidental or consequential damages, expenses, or economic loss, or for any claim or claims for such damage, expense or economic loss. Some states or countries laws vary, so the above limitations or exclusions may not apply to you. For full terms and conditions, refer to the RS website.

Asia

Iso-Tech
460 Alexandra Road, #15-01A
PSA Building
Singapore 119963

USA

7410 Pebble Drive
Fort Worth
Texas 76118-6961

Europe

Iso-Tech
PO Box 99
Corby
Northamptonshire
NN17 9RS
United Kingdom

Canada

1701 Woodward Drive
Ste 108 Ottawa
Ontario K2C 0R4, Canada

Japan

West Tower (12th Floor)
Yokohama Business Park
134 Godocho, Hodogaya
Yokohama, Kanagawa 240-0005 Japan

South America

Av. Pdte. Eduardo Frei M. 6001-71
Centro Empresas El Cortijo
Conchali, Santiago, Chile