

TM3SAK6R

SAFETY MODULE FOR PLC TM2xx, 3 FUNCTIONS, CAT4, SCREW TERMINALS



Main

Range of product	Modicon TM3 Safety
Product or component type	Safety module
Device short name	TM3SAK
Safety module application	For emergency stop, switch, sensing mat/edges or safety light curtain monitoring
Function of module	Emergency stop monitoring 1-channel wiring Emergency stop monitoring 2-channel wiring Monitoring of a movable guard Multiple emergency stop monitoring 2-channel wiring Sensing mat and edges monitoring Monitoring of electro-sensitive protection equipment (ESPE) PNP/PNP Proximity sensor monitoring PNP/PNP Monitoring of electro-sensitive protection equipment (ESPE) PNP/NPN Proximity sensor monitoring PNP/NPN Monitoring of a movable guard with 2 switches and automatic start
Safety level	Can reach PL e/category 4 EN/ISO 13849-1:2008 Can reach PL e/category 4 EN/ISO 13849-2:2012 Can reach SILCL 3 EN/IEC 62061:2005 Can reach SIL 3 EN/IEC 61508:2010

Complementary

Safety reliability data	DC = 95 % EN/ISO 13849-1 PFHd = 5E-9 1/h IEC 61508-1 1 operation/hour DC-13 24 V DC 4 A PFHd = 30E-9 1/h IEC 61508-1 60 operations/hour DC-13 24 V DC 1 A MTTFd = 500 years EN/ISO 13849-1 1 operation/hour DC-13 24 V DC 4 A MTTFd = 85 years EN/ISO 13849-1 60 operations/hour DC-13 24 V DC 1 A SFF = 95 % IEC 61508-1 HFT = 1 IEC 61508-1 Type = A IEC 61508-1
Synchronisation time between inputs	Unlimited 2 or 4 s depending of wiring configurable by software
Connections - terminals	Captive screw clamp terminals, removable terminal block 1 x 0.2...1 x 2.5 mm ² flexible without cable end 13-14, 23-24, 33-34 Captive screw clamp terminals, removable terminal block 1 x 0.2...1 x 2.5 mm ² solid without cable end 13-14, 23-24, 33-34 Captive screw clamp terminals, removable terminal block 1 x 0.25...1 x 2.5 mm ² flexible with cable end, with bezel 13-14, 23-24, 33-34 Captive screw clamp terminals, removable terminal block 1 x 0.25...1 x 2.5 mm ² flexible with cable end, without bezel 13-14, 23-24, 33-34 Captive screw clamp terminals, removable terminal block 2 x 0.2...2 x 1.5 mm ² flexible without cable end 13-14, 23-24, 33-34 Captive screw clamp terminals, removable terminal block 2 x 0.2...2 x 1.5 mm ² solid without cable end 13-14, 23-24, 33-34 Captive screw clamp terminals, removable terminal block 2 x 0.25...2 x 1 mm ² flexible with cable end, without bezel 13-14, 23-24, 33-34 Captive screw clamp terminals, removable terminal block 2 x 0.5...2 x 1.5 mm ² flexible with cable end, with double bezel 13-14, 23-24, 33-34 Captive screw clamp terminals, removable terminal block 1 x 0.14...1 x 1.5 mm ² flexible without cable end other terminals Captive screw clamp terminals, removable terminal block 1 x 0.14...1 x 1.5 mm ² solid without cable end other terminals Captive screw clamp terminals, removable terminal block 1 x 0.25...1 x 0.5 mm ² flexible with cable end, with bezel other terminals Captive screw clamp terminals, removable terminal block 1 x 0.25...1 x 1.5 mm ² flexible with cable end, without bezel other terminals Captive screw clamp terminals, removable terminal block 2 x 0.14...2 x 0.5 mm ² flexible without cable end other terminals

The information provided in this documentation contains general descriptions and/or technical characteristics of the products contained herein. This documentation is not intended as a substitute for and is not to be used for determining suitability or reliability of these products for specific user applications. It is the duty of any such user or integrator to perform the appropriate and complete risk analysis, evaluation and testing of the products with respect to the relevant specific application or use thereof. Neither Schneider Electric Industries SAS nor any of its affiliates or subsidiaries shall be responsible or liable for misuse of the information contained herein.

Captive screw clamp terminals, removable terminal block 2 x 0.14...2 x 0.75 mm² solid without cable end other terminals
 Captive screw clamp terminals, removable terminal block 2 x 0.25...2 x 0.34 mm² flexible with cable end, without bezel other terminals
 Captive screw clamp terminals, removable terminal block 2 x 0.5 mm² flexible with cable end, with double bezel other terminals

Number of safety circuits	3 NO (relay instantaneous opening)
Output type	3 NO relay instantaneous opening potential free
Maximum switching voltage	230 V utilisation category AC-15 at 50 Hz (relay instantaneous opening) 24 V utilisation category DC-13 (relay instantaneous opening)
[Us] rated supply voltage	24 V DC - 15...20 %
Power consumption in W	0.2 W 5 V DC 3.6 W 24 V DC
Input protection type	Internal, electronic
Control circuit voltage	24 V DC
Cable length	<= 30 m
Breaking capacity	360 VA holding AC-15 B300 relay output 3600 VA inrush AC-15 B300 relay output
Breaking capacity	4 A 24 V 50 ms DC-13 relay output
Output thermal current	6 A per relay relay output
[Ith] conventional free air thermal current	18 A
Associated fuse rating	4 A gG or gL relay output EN/IEC 60947-5-1 6 A fast blow relay output EN/IEC 60947-5-1
Minimum output current	10 mA relay output
Output voltage	10 V relay output
Response time on input open	<= 40 ms
[Ui] rated insulation voltage	300 V 2 IEC 60647-5-1
[Uimp] rated impulse withstand voltage	4 kV III IEC 60647-5-1
Current consumption	100 mA 24 V DC external supply
Local signalling	8 LEDs green/red user
Electrical connection	Screw terminal
Product compatibility	Safety light curtains EN/IEC 61496-1 (type 4) Sensing mat/edges EN 1760-1
Standards	EN/ISO 13849-1:2008 EN/ISO 13849-2:2012 EN/IEC 62061:2005 EN/IEC 61508:2010 EN/IEC 60947-5-1:2010 EN/IEC 61131-2:2007 EN/IEC 60204-1:2005 EN/IEC 60204-1:2009/A1 IEC 61010-1:2010 EN 50581:2012
Product certifications	TÜV RCM EAC UL 61010-2-201 CSA 61010-2-201 (pending) ANSI Haz Loc Class 1 Division 2 (pending) CSA Haz Loc Class 1 Division 2 (pending)
Marking	CE CSA UL EFUP 10 REACH TÜV EAC RCM
Electromagnetic compatibility	Electrostatic discharge immunity test 8 kV air discharge conforming to EN/IEC 61000-4-2 Electrostatic discharge immunity test 6 kV contact discharge conforming to EN/IEC 61000-4-2 Susceptibility to electromagnetic fields 10 V/m 80 MHz to 1 GHz conforming to EN/IEC 61000-4-3 Susceptibility to electromagnetic fields 3 V/m 1.4 GHz...2 GHz conforming to EN/IEC 61000-4-3 Susceptibility to electromagnetic fields 1 V/m 2 GHz...3 GHz conforming to EN/IEC 61000-4-3

Magnetic field at power frequency 30 A/m 50...60 Hz conforming to EN/IEC 61000-4-8
 Electrical fast transient/burst immunity test 3 kV power lines (DC) conforming to EN/IEC 61000-4-4
 Electrical fast transient/burst immunity test 2 kV I/O conforming to EN/IEC 61000-4-4
 1.2/50 µs shock waves immunity test 1 kV power lines (DC) conforming to EN/IEC 61000-4-5
 Conducted RF disturbances 10 V 0.15...80 MHz conforming to EN/IEC 61000-4-6
 Radiated emission 40 dBµV/m class A 24 V conforming to EN 55011
 Radiated emission 47 dBµV/m class A 24 V conforming to EN 55011

Mounting support	Wall mount using attached fasteners Rail top hat type TH35-7.5 IEC 60715 Rail top hat type TH35-15 IEC 60715
Height	94 mm
Depth	73 mm
Width	43.7 mm
Product weight	0.19 kg

Environment

standards	EN 1088/ISO 14119 EN 60204-1 EN/IEC 60947-1 EN/IEC 60947-5-1 EN/ISO 13850
resistance to electrostatic discharge	8 kV in air EN/IEC 61000-4-2 6 kV on contact EN/IEC 61000-4-2
resistance to electromagnetic fields	10 V/m 80 MHz...1 GHz EN/IEC 61000-4-3 3 V/m 1.4 GHz...2 GHz EN/IEC 61000-4-3 1 V/m 2 GHz...3 GHz EN/IEC 61000-4-3
resistance to magnetic fields	30 A/m 50...60 Hz EN/IEC 61000-4-8
resistance to fast transients	3 kV power lines (DC) EN/IEC 61000-4-4 DC 2 kV I/O lines EN/IEC 61000-4-4
surge withstand	1 kV power lines (DC) differential mode EN/IEC 61000-4-5 DC 1 kV power lines (DC) common mode EN/IEC 61000-4-5 DC
resistance to conducted disturbances, induced by radio frequency fields	10 V 0.15...80 MHz EN/IEC 61000-4-6
electromagnetic emission	Radiated emissions 50 dBµV/m class A 24 V DC 30...230 Hz IEC 61131-3 Radiated emissions 57 dBµV/m class A 24 V DC 230...1000 Hz IEC 61131-3
ambient air temperature for operation	-10...55 °C horizontal installation
ambient air temperature for storage	-25...70 °C
relative humidity	10...95 % without condensation in operation 10...95 % without condensation in storage
IP degree of protection	IP20 EN/IEC 60529 terminals
pollution degree	2
operating altitude	0...2000 m
storage altitude	0...3000 m
vibration resistance	+/- 3.5 mm 5...150 Hz IEC 60068-2-6
shock resistance	15 gn 11 ms IEC 60068-2-27
mechanical robustness	Bumps 6 ms 300 shocks 25 gn IEC 60068-2-27

Offer Sustainability

Sustainable offer status	Green Premium product
RoHS (date code: YYWW)	Compliant - since 1408 - Schneider Electric declaration of conformity
REACH	Reference not containing SVHC above the threshold
Product environmental profile	Available
Product end of life instructions	Available

Dimensions

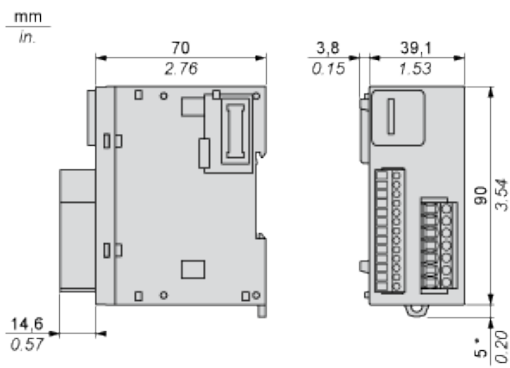

(*) 8.5 mm/0.33 in when the clamp is pulled out.

Spacing Requirements

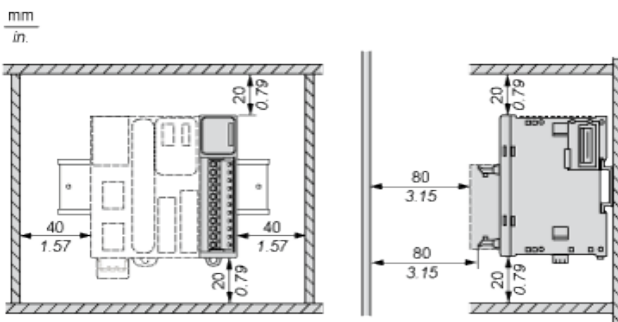

Mounting on a Rail

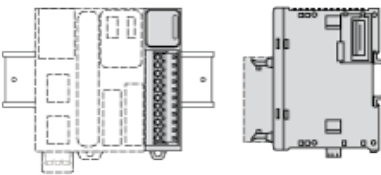

Incorrect Mounting

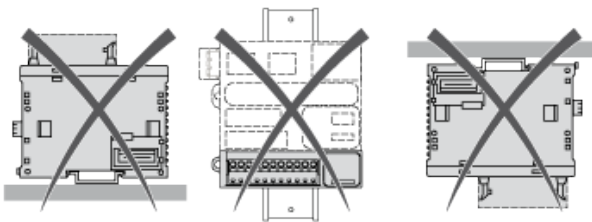

Mounting on a Panel Surface

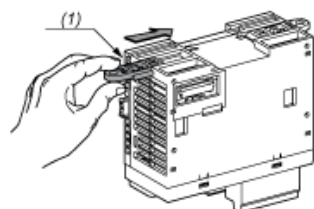

(1) Install a mounting strip

Mounting Hole Layout

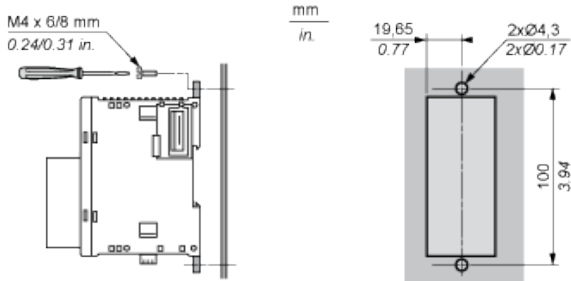

Emergency Stop Wiring Diagram

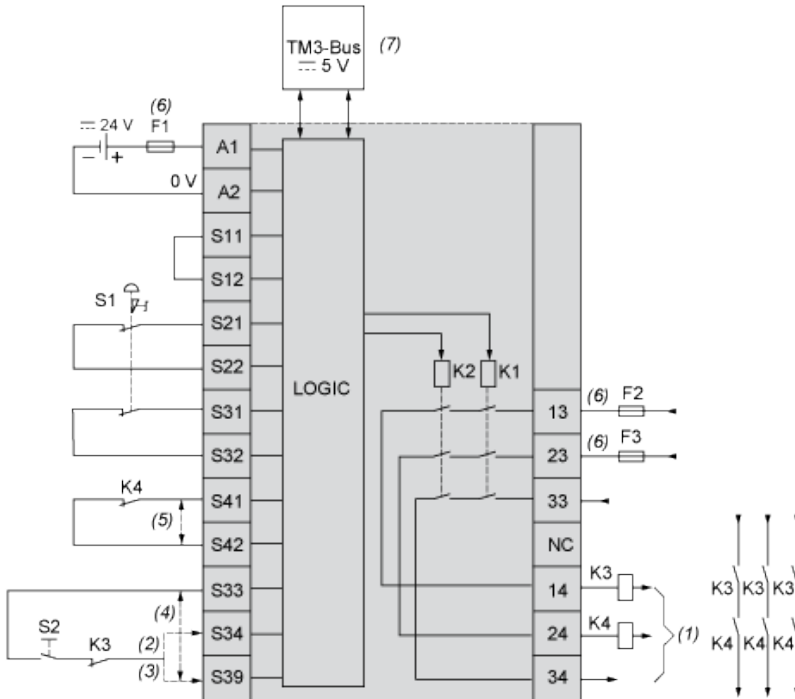

S1 : Emergency stop switch

S2 : Start switch

(1) Safety outputs

(2) Monitored start

(3) Non-monitored start

(4) For automatic start, directly connect [S33] and [S39] terminals

(5) Second external device monitoring channel. Connect [S41] and [S42] terminals if not used

(6) Fuses. Refer to technical specifications for fuse values

(7) Non-safety related TM3 Bus communication with logic controller

Protective Guard Wiring

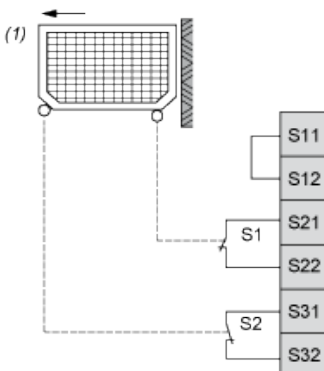

(1) Protective guard

Electro-Sensitive Protective Equipment (ESPE) Wiring

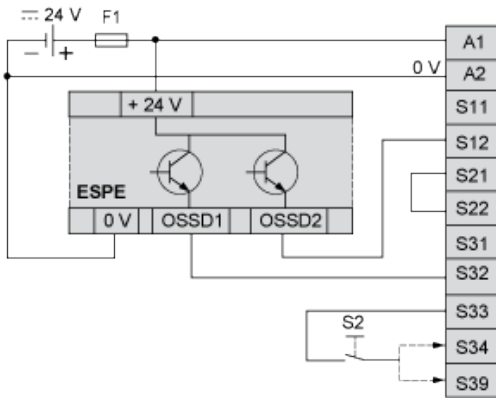

S2: Start switch

NOTE: The ESPE must be supplied by the same PELV/SELV power supply as the safety module.

Safety-Mat Wiring

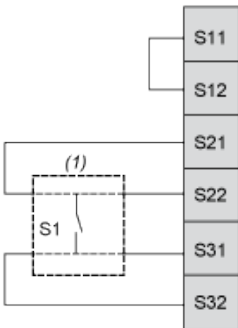

(1) Safety-mat

NOTE: Normally, most safety-mats are maladapted for use in combination with the automatic start mode. In addition, if you use the safety-mat in your application which includes the automatic startmode, you should consider this in your risk analysis.

Emergency Stop Wiring

One Channel

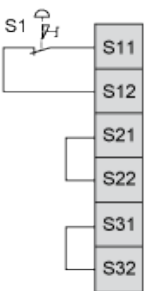

S1: Emergency stop switch

Two Channel

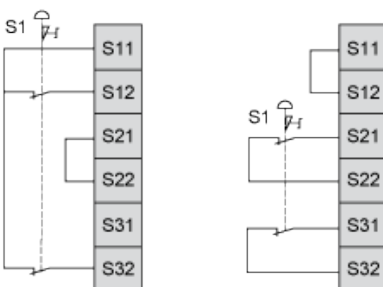

S1: Emergency stop switch

NOTE: Inputs S11 and S12 are not intended for the monitoring of short circuits in external wiring.

Proximity Sensors Wiring

Without Short Circuit Detection

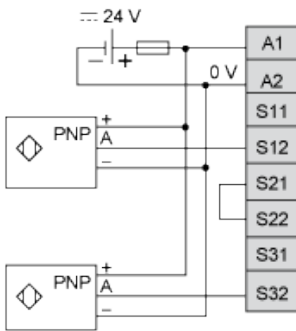

NOTE: The sensors must be supplied by the same PELV/SELV power supply as the safety module.

With Short Circuit Detection

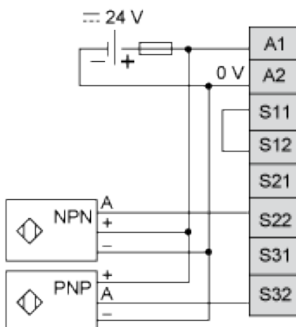

NOTE: The sensors must be supplied by the same PELV/SELV power supply as the safety module.

Synchronization Time Monitoring Chronogram

2 Channel Application

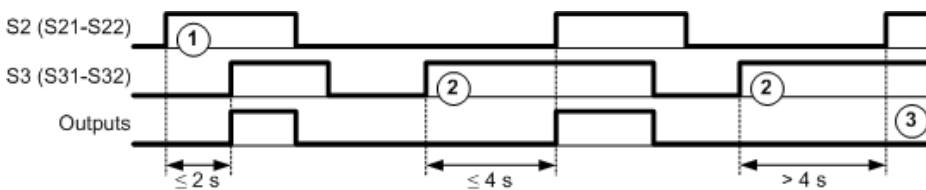

- 1 : S2 operated before S3
- 2 : S3 operated before S2
- 3 : Outputs are not activated because the synchronization time is expired.