

EEV-EX01

SOM-ETX Evaluation Carrier Board

Quick Installation Guide



3rd Ed – 27 March 2006

FCC Statement



THIS DEVICE COMPLIES WITH PART 15 FCC RULES. OPERATION IS SUBJECT TO THE FOLLOWING TWO CONDITIONS:

- (1) THIS DEVICE MAY NOT CAUSE HARMFUL INTERFERENCE.
- (2) THIS DEVICE MUST ACCEPT ANY INTERFERENCE RECEIVED INCLUDING INTERFERENCE THAT MAY CAUSE UNDESIRE OPERATION.

THIS EQUIPMENT HAS BEEN TESTED AND FOUND TO COMPLY WITH THE LIMITS FOR A CLASS "A" DIGITAL DEVICE, PURSUANT TO PART 15 OF THE FCC RULES.

THESE LIMITS ARE DESIGNED TO PROVIDE REASONABLE PROTECTION AGAINST HARMFUL INTERFERENCE WHEN THE EQUIPMENT IS OPERATED IN A COMMERCIAL ENVIRONMENT. THIS EQUIPMENT GENERATES, USES, AND CAN RADIATE RADIO FREQUENCY ENERGY AND, IF NOT INSTALLED AND USED IN ACCORDANCE WITH THE INSTRUCTION MANUAL, MAY CAUSE HARMFUL INTERFERENCE TO RADIO COMMUNICATIONS.

OPERATION OF THIS EQUIPMENT IN A RESIDENTIAL AREA IS LIKELY TO CAUSE HARMFUL INTERFERENCE IN WHICH CASE THE USER WILL BE REQUIRED TO CORRECT THE INTERFERENCE AT HIS OWN EXPENSE.

Notice

This guide is designed for experienced users to setup the system within the shortest time. For detailed information, please always refer to the electronic user's manual.

Copyright Notice

Copyright © 2005-2006 Evalve Technology Inc., ALL RIGHTS RESERVED.

No part of this document may be reproduced, copied, translated, or transmitted in any form or by any means, electronic or mechanical, for any purpose, without the prior written permission of the original manufacturer.

Trademark Acknowledgement

Brand and product names are trademarks or registered trademarks of their respective owners.

Disclaimer

Evalue Technology Inc. reserves the right to make changes, without notice, to any product, including circuits and/or software described or contained in this manual in order to improve design and/or performance. Evalue Technology assumes no responsibility or liability for the use of the described product(s), conveys no license or title under any patent, copyright, or masks work rights to these products, and makes no representations or warranties that these products are free from patent, copyright, or mask work right infringement, unless otherwise specified. Applications that are described in this manual are for illustration purposes only. Evalue Technology Inc. makes no representation or warranty that such application will be suitable for the specified use without further testing or modification.

Life Support Policy

Evalue Technology's PRODUCTS ARE NOT FOR USE AS CRITICAL COMPONENTS IN LIFE SUPPORT DEVICES OR SYSTEMS WITHOUT THE PRIOR WRITTEN APPROVAL OF Evalue Technology Inc.

As used herein:

1. Life support devices or systems are devices or systems which, (a) are intended for surgical implant into body, or (b) support or sustain life and whose failure to perform, when properly used in accordance with instructions for use provided in the labeling, can be reasonably expected to result in significant injury to the user.
2. A critical component is any component of a life support device or system whose failure to perform can be reasonably expected to cause the failure of the life support device or system, or to affect its safety or effectiveness.

A Message to the Customer

Evalue Customer Services

Each and every Evalue's product is built to the most exacting specifications to ensure reliable performance in the harsh and demanding conditions typical of industrial environments. Whether your new Evalue device is destined for the laboratory or the factory floor, you can be assured that your product will provide the reliability and ease of operation for which the name Evalue has come to be known.

Your satisfaction is our primary concern. Here is a guide to Evalue's customer services. To ensure you get the full benefit of our services, please follow the instructions below carefully.

Technical Support

We want you to get the maximum performance from your products. So if you run into technical difficulties, we are here to help. For the most frequently asked questions, you can easily find answers in your product documentation. These answers are normally a lot more detailed than the ones we can give over the phone. So please consult the user's manual first.

To receive the latest version of the user's manual; please visit our Web site at:

<http://www.evaluate-tech.com/>

If you still cannot find the answer, gather all the information or questions that apply to your problem, and with the product close at hand, call your dealer. Our dealers are well trained and ready to give you the support you need to get the most from your Evaluate's products. In fact, most problems reported are minor and are able to be easily solved over the phone.

In addition, free technical support is available from Evaluate's engineers every business day. We are always ready to give advice on application requirements or specific information on the installation and operation of any of our products. Please do not hesitate to call or e-mail us.

Headquarters

Evalue Technology Inc.

7F, 228, Lian-cheng Road,
Chung Ho City, Taipei,
Taiwan

Tel : +886-2-8226-2345

Fax : +886-2-8226-2777

<http://www.evaluate-tech.com>

E-mail: service@evaluate-tech.com

Europe Branch Office

Evalue Europe A/S

Stenholttsvej 13,
3480 Fredensborg,
Denmark

Tel : +45-7025-0310

Fax : +45-4975-5026

<http://www.evaluate-tech.com>

E-mail: service.europe@evaluate-tech.com

China Branch Office

Evalue Technology Shanghai Inc.

Room 909, 9F, Section B, No.900,
Yisan Road, Caohejing Hi-tech Park,
Shanghai 200233, China

Tel : +86-21-5423-4170

Fax : +86-21-5423-4171

<http://www.evaluate-tech.com>

E-mail: service.china@evaluate-tech.com

US Branch Office

Evalue Technology Inc.

Suite 210, 200 Tornillo Way,
Tinton Falls, NJ 07712
USA

Tel: +1-732-578-0200

Fax: +1-732-578-0250

<http://www.evaluate-tech.com>

E-mail: service.usa@evaluate-tech.com

Product Warranty

Evalue warrants to you, the original purchaser, that each of its products will be free from defects in materials and workmanship for two years from the date of purchase.

This warranty does not apply to any products which have been repaired or altered by persons other than repair personnel authorized by Evalue, or which have been subject to misuse, abuse, accident or improper installation. Evalue assumes no liability under the terms of this warranty as a consequence of such events. Because of Evalue's high quality-control standards and rigorous testing, most of our customers never need to use our repair service. If any of Evalue's products is defective, it will be repaired or replaced at no charge during the warranty period. For out-of-warranty repairs, you will be billed according to the cost of replacement materials, service time, and freight. Please consult your dealer for more details. If you think you have a defective product, follow these steps:

1. Collect all the information about the problem encountered. (For example, CPU type and speed, Evalue's products model name, hardware & BIOS revision number, other hardware and software used, etc.) Note anything abnormal and list any on-screen messages you get when the problem occurs.
2. Call your dealer and describe the problem. Please have your manual, product, and any helpful information available.
3. If your product is diagnosed as defective, obtain an RMA (return material authorization) number from your dealer. This allows us to process your good return more quickly.
4. Carefully pack the defective product, a complete Repair and Replacement Order Card and a photocopy proof of purchase date (such as your sales receipt) in a shippable container. A product returned without proof of the purchase date is not eligible for warranty service.
5. Write the RMA number visibly on the outside of the package and ship it prepaid to your dealer.

Contents

1. Getting Started	7
1.1 Safety Precautions	7
1.2 Packing List	7
2. Hardware Configuration	8
2.1 Product Overview	9
2.2 Jumper and Connector List	10
2.3 Setting Jumpers & Connectors	13
2.3.1 DOC Memory Address Select (J1)	13
2.3.2 AT/ATX Power Select (J6).....	13
2.3.3 Clear CMOS (J7)	14
2.3.4 Compact Flash Master/Slave Mode Select (J8)	14
2.3.5 COM2 RS-232/422/485 Signal Select (JP1, JP2, JP3).....	15
2.3.6 Active/Speed LAN LED Select (JP4).....	15
2.3.7 Active/Speed LAN LED Select (JP5).....	16
2.3.8 CD-ROM Audio Input Connector 1 (CN4)	16
2.3.9 CD-ROM Audio Input Connector 2 (CN5)	17
2.3.10 LVDS Connector (CN6)	17
2.3.11 IrDA Connector (CN8)	18
2.3.12 Speaker Connector (CN10).....	19
2.3.13 Keyboard Lock Connector (CN11)	19
2.3.14 Floppy Connector (FLP1)	20
2.3.15 TV Output Connector (J2)	21
2.3.16 Ring-In Connector (J4)	21
2.3.17 SIRQ Connector (J5)	22
2.3.18 IDE Activity LED Connector (J9)	22
2.3.19 Reset Connector (J10)	23
2.3.20 ATX Power Switch Connector (J11).....	23
2.3.21 SMI Input Connector (J12)	24

1. Getting Started

1.1 Safety Precautions

Warning!



Always completely disconnect the power cord from your chassis whenever you work with the hardware. Do not make connections while the power is on. Sensitive electronic components can be damaged by sudden power surges. Only experienced electronics personnel should open the PC chassis.

Caution!



Always ground yourself to remove any static charge before touching the CPU card. Modern electronic devices are very sensitive to static electric charges. As a safety precaution, use a grounding wrist strap at all times. Place all electronic components in a static-dissipative surface or static-shielded bag when they are not in the chassis.

1.2 Packing List

Before you begin installing your single board, please make sure that the following materials have been shipped:

- 1 x EEV-EX01 SOM-ETX Evaluation Carrier Board
- 1 x Quick Installation Guide
- 1 x CD-ROM or DVD-ROM contains the followings:
 - User's Manual (this manual in PDF file)
 - Ethernet driver and utilities
 - VGA drivers and utilities
 - Audio drivers and utilities
- Cable set includes the followings:
 - 1 IDE HDD cable (40-pin, pitch 2.54mm)
 - 1 FDD cable (34-pin, pitch 2.54mm)



If any of the above items is damaged or missing, contact your retailer.

2. Hardware Configuration

2.1 Product Overview

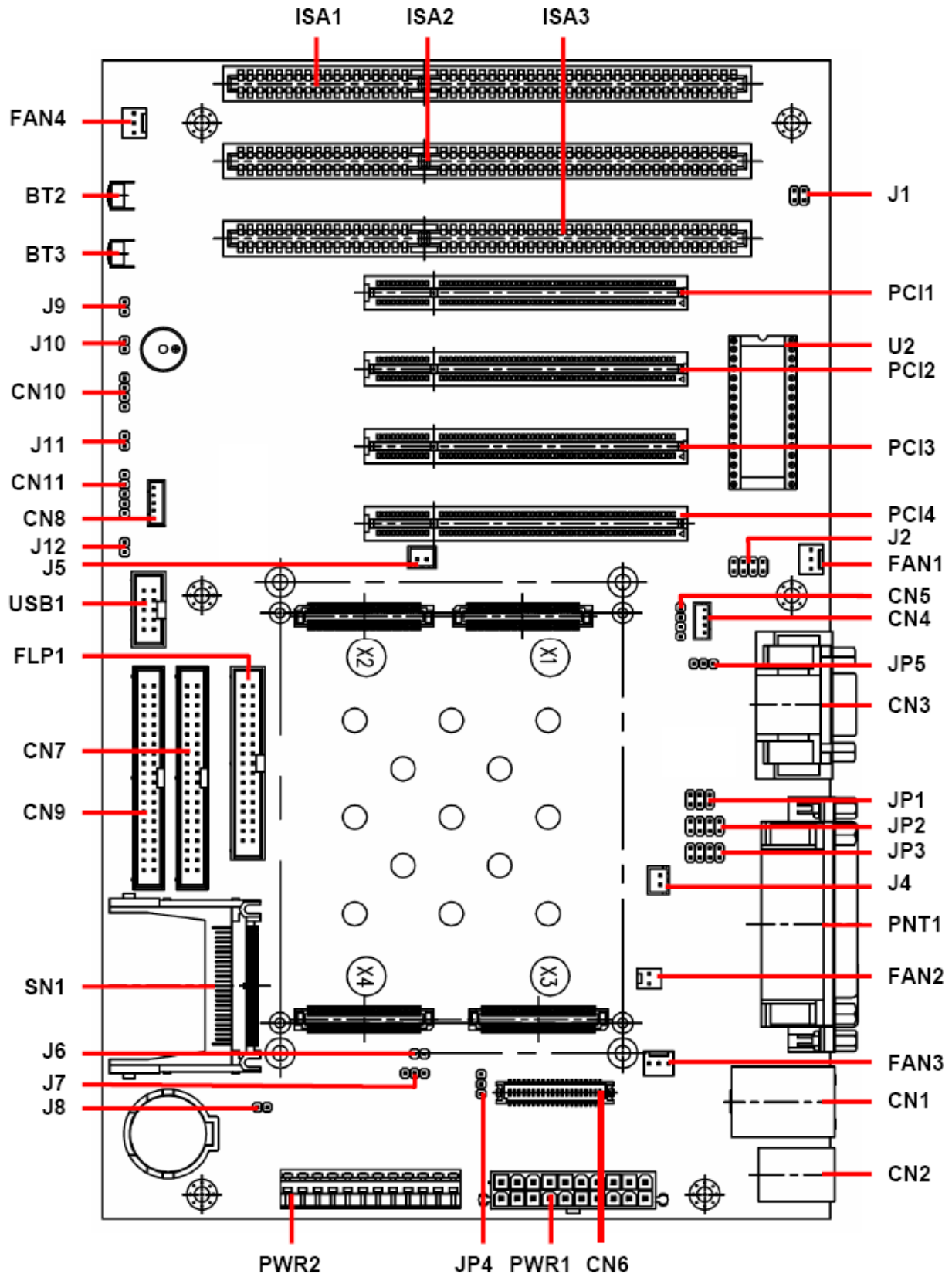

2.2 Jumper and Connector List

You can configure your board to match the needs of your application by setting jumpers. A jumper is the simplest kind of electric switch.

It consists of two metal pins and a small metal clip (often protected by a plastic cover) that slides over the pins to connect them. To “close” a jumper you connect the pins with the clip. To “open” a jumper you remove the clip. Sometimes a jumper will have three pins, labeled 1, 2, and 3. In this case, you would connect either two pins.

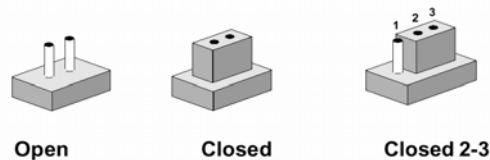

The jumper settings are schematically depicted in this manual as follows:



A pair of needle-nose pliers may be helpful when working with jumpers.

Connectors on the board are linked to external devices such as hard disk drives, a keyboard, or floppy drives. In addition, the board has a number of jumpers that allow you to configure your system to suit your application.

If you have any doubts about the best hardware configuration for your application, contact your local distributor or sales representative before you make any changes.

The following tables list the function of each of the board's jumpers and connectors.

Jumpers

Label	Function	Note
J1	DOC memory address select	2 x 2 header, pitch 2.54mm
J6	AT/ATX power select	2 x 1 header, pitch 2.54mm
J7	Clear CMOS	3 x 1 header, pitch 2.54mm
J8	Compact Flash Master / Slave mode select	2 x 1 header, pitch 2.54mm
JP1	COM2 RS-232/422/485 select	3 x 2 header, pitch 2.54mm
JP2	COM2 RS-232/422/485 select	4 x 2 header, pitch 2.54mm
JP3	COM2 RS-232/422/485 select	4 x 2 header, pitch 2.54mm
JP4	Active/Speed LAN LED select	3 x 1 header, pitch 2.54mm
JP5	2.1 CH./5.1 CH. audio select	3 x 1 header, pitch 2.54mm

Connectors

Label	Function	Note
BT2	Reset button	
BT3	Power on switch button	
CN1	10/100Base-Tx Ethernet & USB connector	Double deck RJ-45 & USB RJ-45 valid only if the SOM-ETX CPU module w/ LAN function is implemented
CN2	PS/2 keyboard & mouse connector	Double deck 6-pin mini DIN
CN3	Audio / CRT connector	Double deck DB-15 female & Audio jacks x 3
CN4	CD-ROM audio input connector 1	4 x 1 wafer, pitch 2.0mm
CN5	CD-ROM audio input connector 2	4 x 1 header, pitch 2.54mm
CN6	LVDS connector	HIROSE DF13-40DP-1.25V
CN7	IDE1 connector	20 x 2 header, pitch 2.54mm
CN8	IrDA connector	5 x 1 header, pitch 2.54mm
CN9	IDE2 connector	20 x 2 header, pitch 2.54mm
CN10	Speaker connector	4 x 1 header, pitch 2.54mm
CN11	Keyboard lock connector	5 x 1 header, pitch 2.54mm
FAN1	System fan connector 1	3 x 1 wafer, pitch 2.54mm
FAN2	CPU fan connector 1	2 x 1 wafer, pitch 2.54mm
FAN3	CPU fan connector 2	3 x 1 wafer, pitch 2.54mm
FAN4	System fan connector 2	3 x 1 wafer, pitch 2.54mm
FLP1	Floppy connector	17 x 2 header, pitch 2.54mm
ISA1	ISA connector 1	
ISA2	ISA connector 2	
ISA3	ISA connector 3	
J2	TV output connector	5 x 2 header, pitch 2.54mm
J4	Ring-In Connector	2 x 1 wafer, pitch 2.54mm
J5	SIRQ connector	2 x 1 wafer, pitch 2.54mm
J9	IDE activity LED connector	2 x 1 header, pitch 2.54mm
J10	Reset connector	2 x 1 header, pitch 2.54mm

Connectors

Label	Function	Note
J11	ATX power switch connector	2 x 1 header, pitch 2.54mm
J12	SMI input connector	2 x 1 header, pitch 2.54mm
PCI1	PCI connector 1	
PCI2	PCI connector 2	
PCI3	PCI connector 3	
PCI4	PCI connector 4	
PNT1	Printer port & serial port 1/2 connector	Double deck DB-25 female & DB-9 male x 2
PWR1	ATX Power connector	
PWR2	AT Power connector	
SN1	Compact Flash card socket	
U2	M-Systems DiskOnChip socket	
USB1	USB connector	5 x 2 header, pitch 2.54mm
X1	ETX connector X1	HIROSE Fx8-100S-SV
X2	ETX connector X2	HIROSE Fx8-100S-SV
X3	ETX connector X3	HIROSE Fx8-100S-SV
X4	ETX connector X4	HIROSE Fx8-100S-SV

2.3 Setting Jumpers & Connectors

2.3.1 DOC Memory Address Select (J1)

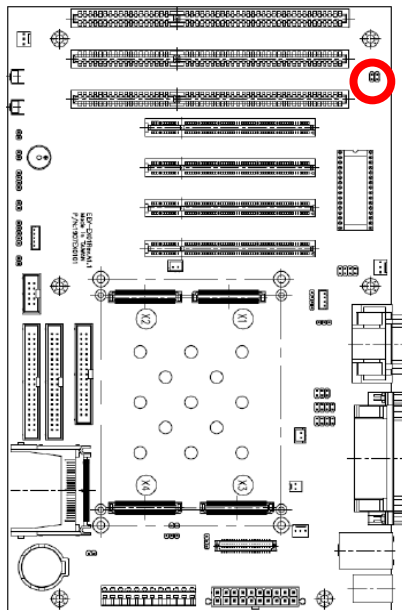

* Default

D0000*

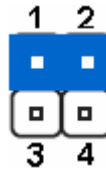

D4000

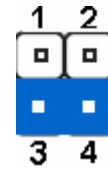

D8000



Disabled



2.3.2 AT/ATX Power Select (J6)

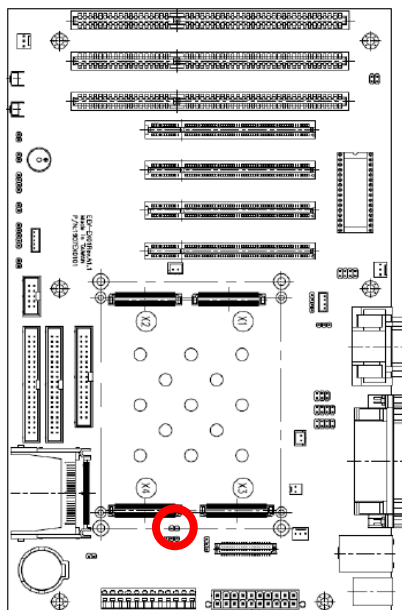

* Default

AT P/S*

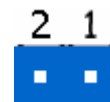

ATX P/S

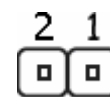

EEV-EX01

2.3.3 Clear CMOS (J7)

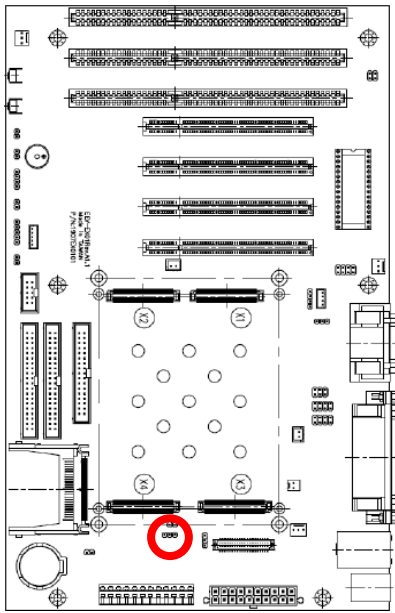

Protect*

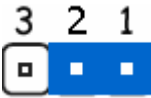

Clear CMOS

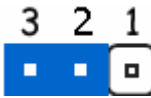

* Default

2.3.4 Compact Flash Master/Slave Mode Select (J8)

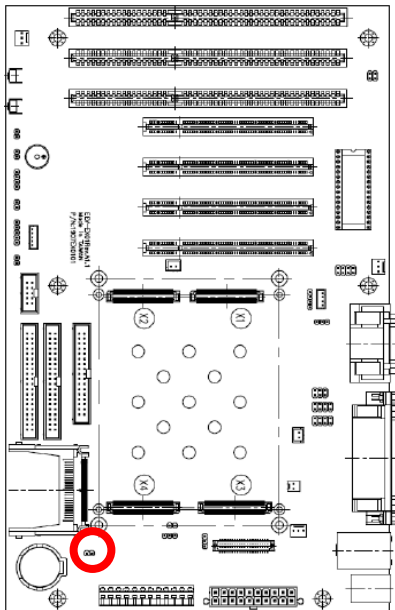

Master*

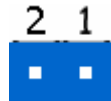

Slave

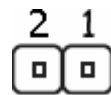

* Default

2.3.5 COM2 RS-232/422/485 Signal Select (JP1, JP2, JP3)

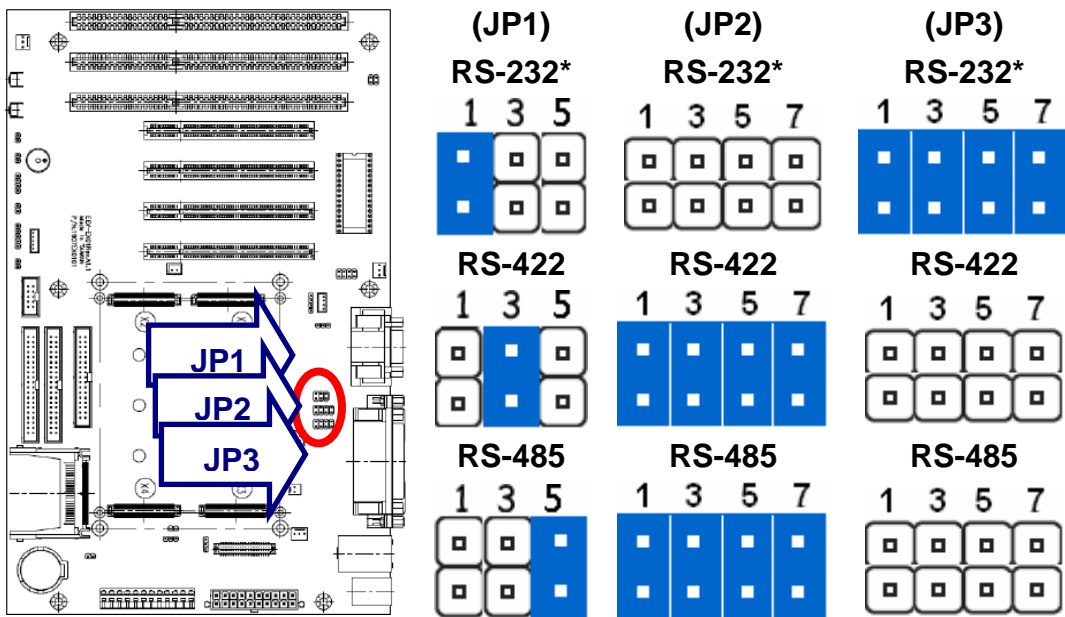

* Default

2.3.6 Active/Speed LAN LED Select (JP4)

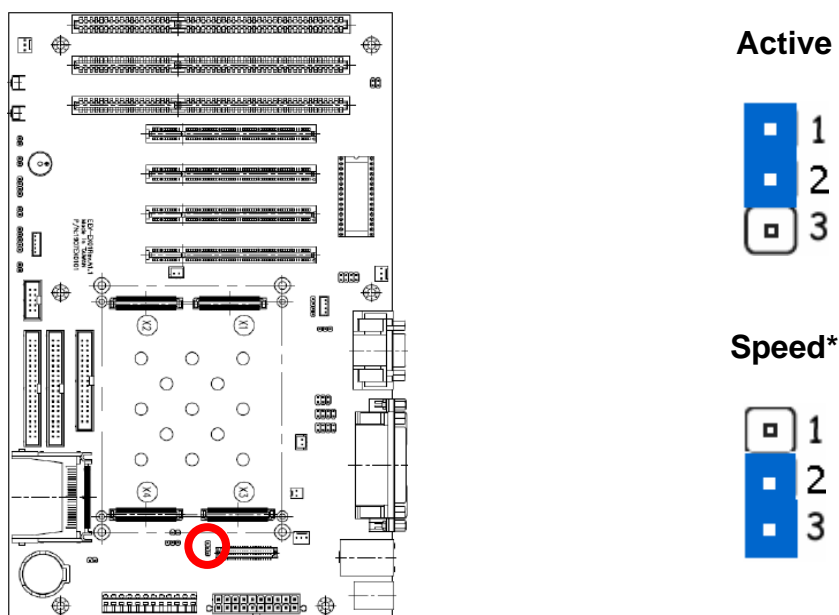

* Default

EEV-EX01

2.3.7 Active/Speed LAN LED Select (JP5)

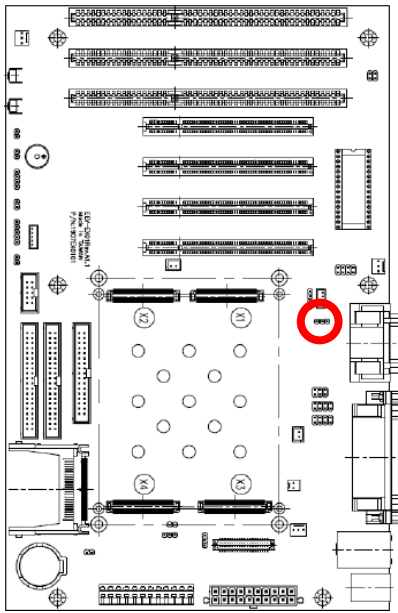

5.1 CH.
 (for ESM-2646, ESM-2740,
 ESM-2743)

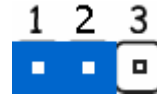

2.1 CH.*
 (for ESM-2440, ESM-2640,
 ESM-2643, ESM-2645)

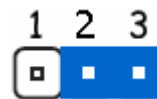

* Default

2.3.8 CD-ROM Audio Input Connector 1 (CN4)

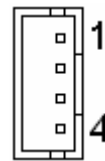
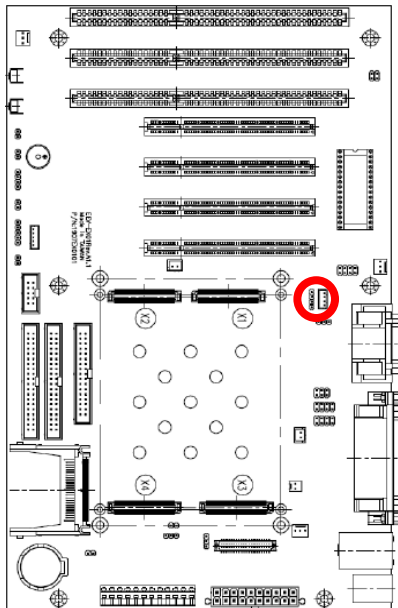

Signal	PIN
GND	1
CD_R	2
GND	3
CD_L	4

2.3.9 CD-ROM Audio Input Connector 2 (CN5)

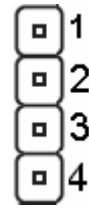
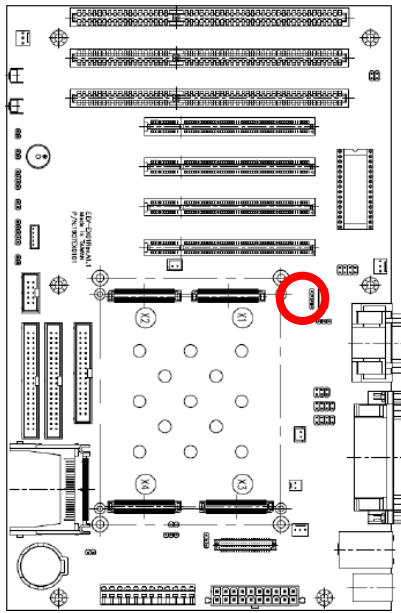

Signal	PIN
CD_R	1
GND	2
GND	3
CD_L	4

2.3.10 LVDS Connector (CN6)

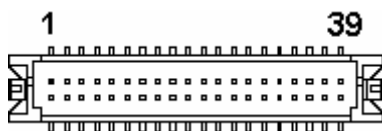
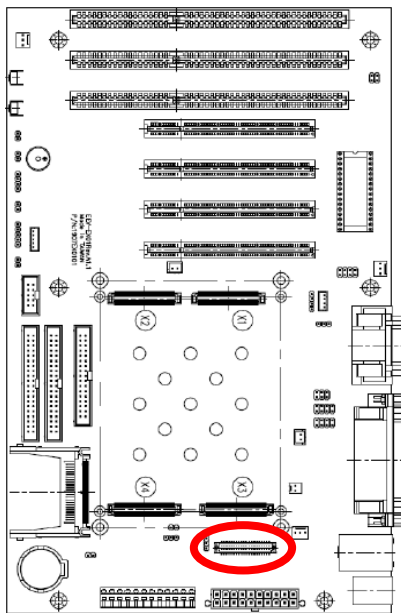

Signal	PIN	PIN	Signal
+5V	2	1	+5V
GND	4	3	GND
+3.3V	6	5	+3.3V
GND	8	7	VCON
E_Txout3#	10	9	E_Txout3
LTGIO0	12	11	I ² C_DAT
ENVDD	14	13	I ² C_CLK
ENAVEE	16	15	SYNC
NC	18	17	DETECT#
Txout3#	20	19	Txout3
GND	22	21	GND
Txout2#	24	23	Txout2
E_Txout1#	26	25	E_Txout1
E_Txclk#	28	27	E_Txclk
E_Txout0#	30	29	E_Txout0
Txclk#	32	31	Txclk
GND	34	33	GND
Txout0#	36	35	Txout0
E_Txout2#	38	37	E_Txout2
Txout1#	40	39	Txout1

EEV-EX01

2.3.10.1 Signal Description – LVDS Connector (CN6)

Signal	Description
ENVDD	This signal is driven high to external logic to initiate a flat panel power up sequence.
ENVEE	This signal is driven high to a programmable time after ENVDD is driven high during a flat panel power up sequence.
DETECT#	Panel hot plug detection. Implementation of this pin is optional. See the specific ETX module product user's manual for details.
GND	Power return.
I ² C_DAT, I ² C_CLK	I ² C interface for panel parameter EEPROM. This EEPROM is mounted on the LVDS receiver. The data in the EEPROM allows the EXT module to automatically set the proper timing parameters for a specific LCD panel.
LTGIO0	General purpose I/O pin.
SYNC	Composite Sync for RGB Video (SCART).

2.3.11 IrDA Connector (CN8)

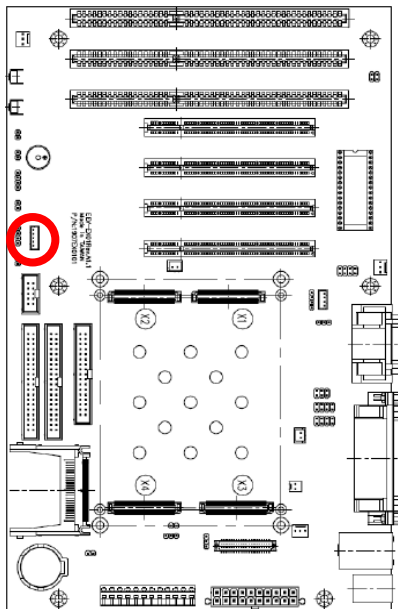

Signal	PIN
IRTX	5
GND	4
IRRX	3
NC	2
+5V	1

2.3.12 Speaker Connector (CN10)

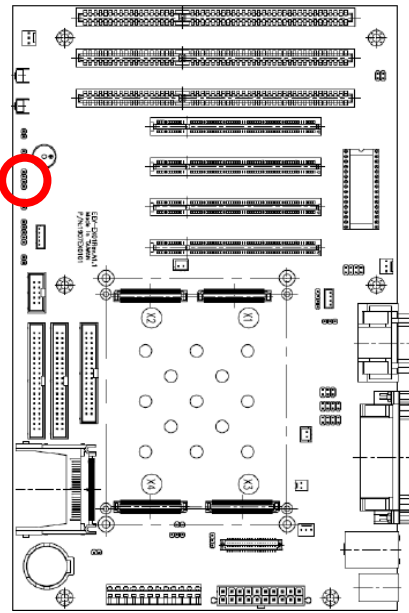

Signal	PIN
+5V	1
NC	2
BUZZ	3
Speaker	4



Note:

To select the onboard buzzer, please short CN10 pin 3 & 4.

2.3.13 Keyboard Lock Connector (CN11)

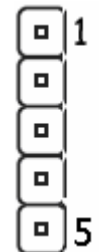
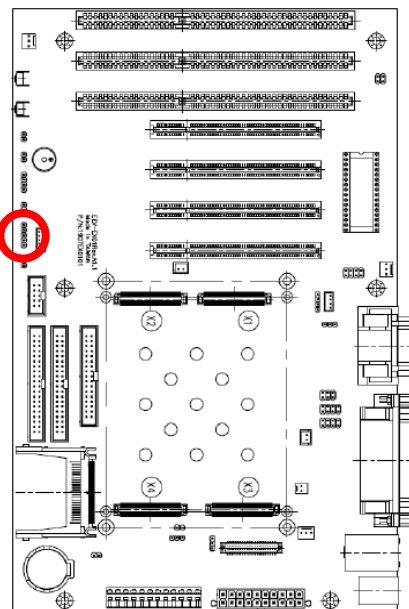

Signal	PIN
PWLED	1
NC	2
GND	3
KB_LOCK	4
GND	5

EEV-EX01

2.3.14 Floppy Connector (FLP1)

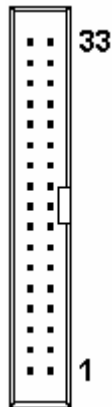
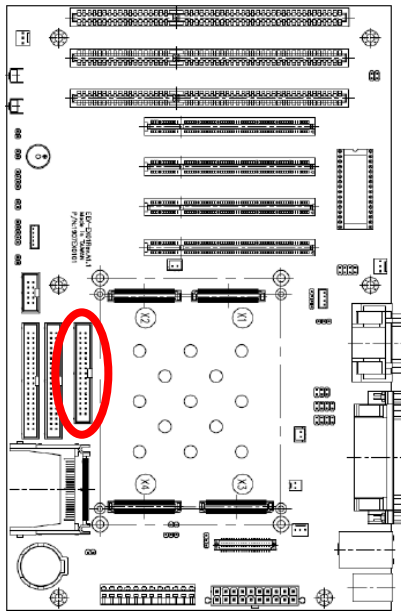

Signal	PIN	PIN	Signal
DSKCHG	34	33	GND
SIDE1	32	31	GND
RDATA	30	29	GND
WPT	28	27	GND
TK00	26	25	GND
WGATE	24	23	GND
WDATA	22	21	GND
STEP	20	19	GND
DIR	18	17	GND
MOTEB	16	15	GND
DRVSA	14	13	GND
DRVSB	12	11	GND
MOTSA	10	9	GND
INDEX	8	7	GND
NC	6	5	GND
NC	4	3	GND
REDWC	2	1	GND



Note:

1. Please adjust the right connection of the FDD cable.

General FDD cable configuration

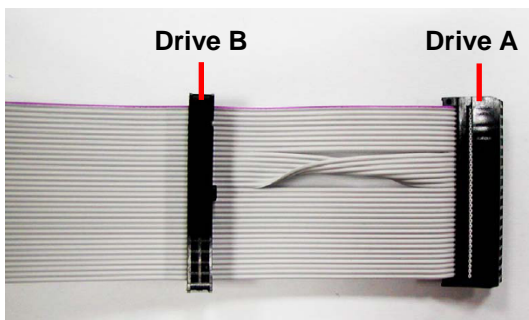

EEV-EX01 FDD cable configuration

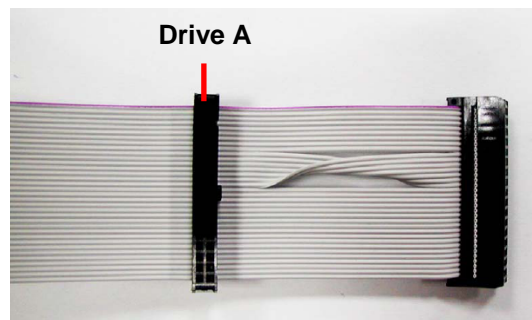

2. BIOS setups : **1.44M, 3.5 in** at Drive A of Standard CMOS Features.
Floppy at Onboard Parallel Port of Integrated Peripherals.
Enabled at Swap Floppy Driver of Advanced BIOS Features.

2.3.15 TV Output Connector (J2)

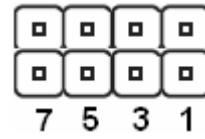
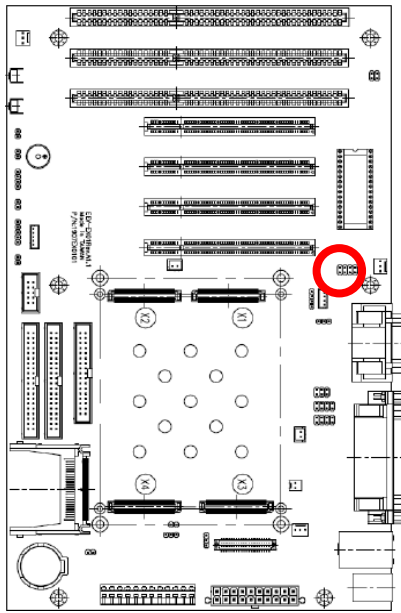

Signal	PIN	PIN	Signal
YOUT	2	1	GND
GND	4	3	COMP
COUT	6	5	GND
NC	8	7	GND

2.3.16 Ring-In Connector (J4)

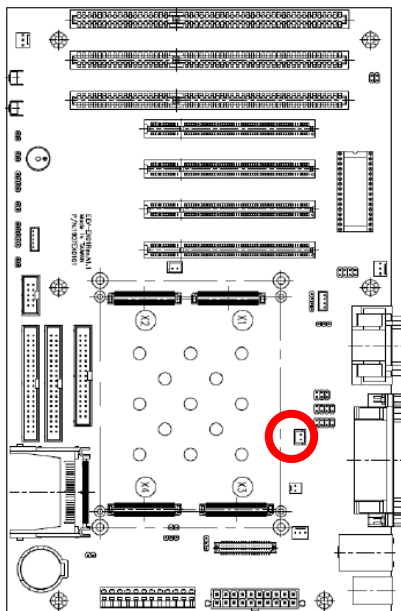

Signal	PIN
RI#	1
GND	2

EEV-EX01

2.3.17 SIRQ Connector (J5)

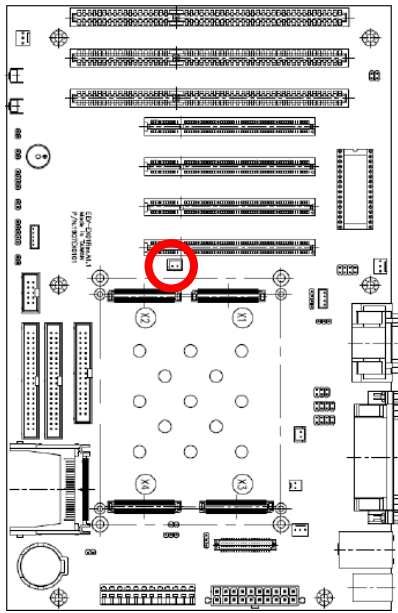

Signal	PIN
SIRQ	1
GND	2



Note:

Valid only if the SOM-ETX CPU module supports serial IRQ function.

2.3.18 IDE Activity LED Connector (J9)

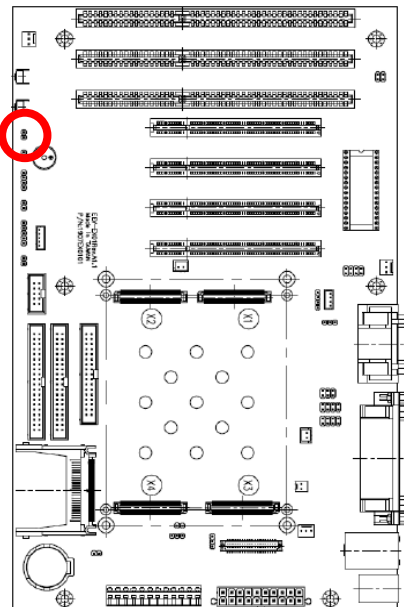

Signal	PIN
+5V	1
HLD	2

2.3.19 Reset Connector (J10)

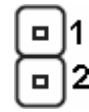
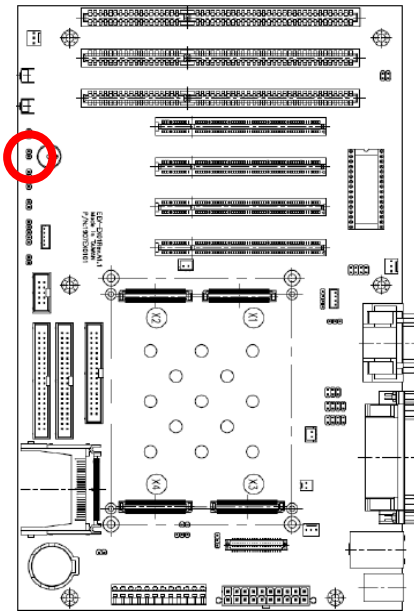

Signal	PIN
RSTIN	1
GND	2

2.3.20 ATX Power Switch Connector (J11)

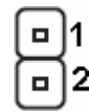
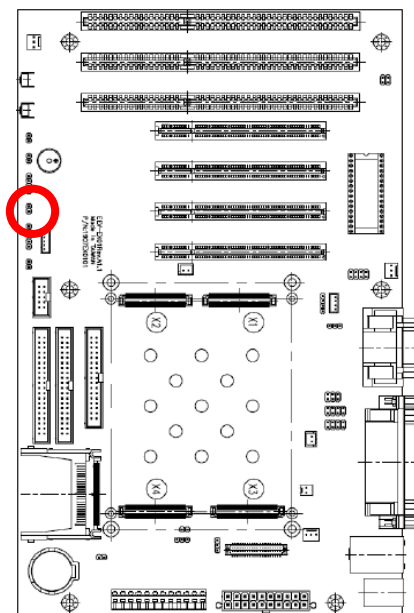

Signal	PIN
PWBT	1
GND	2

EEV-EX01

2.3.21 SMI Input Connector (J12)

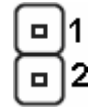
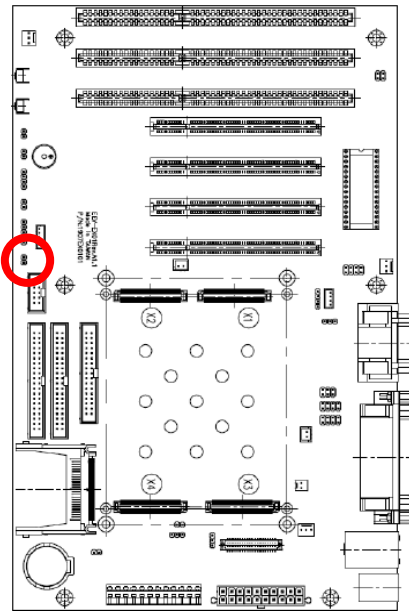

Signal	PIN
EXTSMI#	1
GND	2

