



EN Operating instructions..... pages 1 to 8
Translation of the original operating instructions

Content

1 About this document

1.1 Function 1

1.2 Target group: authorised qualified personnel..... 1

1.3 Explanation of the symbols used 1

1.4 Appropriate use 1

1.5 General safety instructions 1

1.6 Warning about misuse 1

1.7 Exclusion of liability 2

2 Product description

2.1 Ordering code 2

2.2 Special versions..... 2

2.3 Destination and use 2

2.4 Technical data 2

2.5 Safety classification 3

3 Mounting

3.1 General mounting instructions 3

3.2 Dimensions 3

4 Electrical connection

4.1 General information for electrical connection..... 3

5 Operating principle and settings

5.1 Notes 4

5.2 Setting report SRB 324ST V.3 5

6 Set-up and maintenance

6.1 Functional testing..... 5

6.2 Maintenance 5

7 Disassembly and disposal

7.1 Disassembly..... 5

7.2 Disposal..... 5

8 Appendix

8.1 Wiring examples 5

8.2 Start configuration 5

8.3 Sensor configuration 6

8.4 Actuator configuration 7

8.5 EC Declaration of conformity 8

1 About this document

1.1 Function

This operating instructions manual provides all the information you need for the mounting, set-up and commissioning to ensure the safe operation and disassembly of the safety-monitoring module. The operating instructions must be available in a legible condition and a complete version in the vicinity of the device.

1.2 Target group: authorised qualified personnel

All operations described in this operating instructions manual must be carried out by trained specialist personnel, authorised by the plant operator only.

Please make sure that you have read and understood these operating instructions and that you know all applicable legislations regarding occupational safety and accident prevention prior to installation and putting the component into operation.

The machine builder must carefully select the harmonised standards to be complied with as well as other technical specifications for the selection, mounting and integration of the components.

1.3 Explanation of the symbols used



Information, hint, note:

This symbol is used for identifying useful additional information.



Caution: Failure to comply with this warning notice could lead to failures or malfunctions.

Warning: Failure to comply with this warning notice could lead to physical injury and/or damage to the machine.

1.4 Appropriate use

The products described in these operating instructions are developed to execute safety-related functions as part of an entire plant or machine. It is the responsibility of the manufacturer of a machine or plant to ensure the proper functionality of the entire machinery or plant.

The safety-monitoring module must be exclusively used in accordance with the versions listed below or for the applications authorised by the manufacturer. Detailed information regarding the range of applications can be found in the chapter "Product description".

1.5 General safety instructions

The user must observe the safety instructions in this operating instructions manual, the country-specific installation standards as well as all prevailing safety regulations and accident prevention rules.



Further technical information can be found in the Elan catalogues or in the online catalogue on the Internet: www.schmersal.net.

The information contained in this operating instructions manual is provided without liability. Subject to technical modifications.

There are no residual risks, provided that the safety instructions as well as the instructions regarding mounting, commissioning, operation and maintenance are observed.

1.6 Warning about misuse



In case of inadequate or improper use or manipulations of the safety-monitoring module, personal hazards or damage to machinery or plant components cannot be excluded. The relevant requirements of the standard EN 1088 must be observed.

1.7 Exclusion of liability

We shall accept no liability for damages and malfunctions resulting from defective mounting or failure to comply with this operating instructions manual. The manufacturer shall accept no liability for damages resulting from the use of unauthorised spare parts or accessories.

For safety reasons, invasive work on the device as well as arbitrary repairs, conversions and modifications to the device are strictly forbidden; the manufacturer shall accept no liability for damages resulting from such invasive work, arbitrary repairs, conversions and/or modifications to the device.

2 Product description

2.1 Ordering code

This operating instructions manual applies to the following types:

SRB 324ST V.3



Only if the information described in this operating instructions manual are realised correctly, the safety function and therefore the compliance with the Machinery Directive is maintained.

2.2 Special versions

For special versions, which are not listed in the order code below 2.1, these specifications apply accordingly, provided that they correspond to the standard version.

2.3 Destination and use

The safety-monitoring modules for integration in safety circuits are designed for fitting in control cabinets. They are used for the safe evaluation of the signals of positive break position switches for safety functions or magnetic safety sensors on sliding, hinged and removable safety guards as well as emergency stop control devices and AOPD's (safety light barriers).

The safety function is defined as the opening of the enabling circuits 13-14, 23-24 and 33-34 and the delayed opening of the enabling circuits 47-48 and 57-58 when the inputs S11-S12 and/or S21-S22 are opened. The safety-relevant current paths with the output contacts 13-14, 23-24 and 33-34 meet the following requirements under observation of a B_{10d} value assessment (also refer to "Requirements to DIN EN ISO 13849-1"):

- control category 4 – PL e to DIN EN ISO 13849-1
- corresponds to SIL 3 to DIN EN 61508-2
- corresponds to SILCL 3 to DIN EN 62061 (corresponds to control category 4 to DIN EN 954-1)

The safety-relevant current path with the output contacts 47-48 and 57-58 meets the following requirements under observation of a B_{10d} value assessment (also refer to "Requirements to DIN EN ISO 13849-1"):

- control category 3 – PL d to DIN EN ISO 13849-1
- corresponds to SIL 2 to DIN EN 61508-2
- corresponds to SILCL 2 to DIN EN 62061 (corresponds to control category 3 to DIN EN 954-1)

To determine the Performance Level (PL) of the entire safety function (e.g. sensor, logic, actuator) to DIN EN ISO 13849-1, an analysis of all relevant components is required.

2.4 Technical data

General data:	
Standards:	IEC/EN 60204-1, EN 60947-5-1, EN ISO 13849-1, IEC/EN 61508
Climate resistance:	EN 60068-2-78
Fixing:	Snaps onto standard DIN rails to DIN EN 60715
Terminal designations:	EN 60947-1
Material of the enclosure:	glass-fibre reinforced thermoplastic, ventilated
Material of the contacts:	AgSnO, AgNi, self-cleaning, positive drive
Weight:	420 g
Start conditions	automatic or start button (monitored)
Feedback circuit available:	Yes
Pull-in delay for automatic start:	typ. 400 ms
Pull-in delay with reset button:	typ. 30 ms
Drop-out delay in case of emergency stop:	typ. 30 ms
Drop-out delay on "supply failure":	typ. 80 ms
Mechanical data:	
Connection type:	Screw terminals
Cable section:	min. 2 mm ² / max. 2 mm ²
Connecting cable:	rigid or flexible
Tightening torque for the terminals:	0.6 Nm
With removable terminals:	Yes
Mechanical life:	10 million operations
Resistance to shock:	10 g / 11 ms
Resistance to vibrations to EN 60068-2-6:	10 ... 55 Hz, amplitude 0.35 mm
Ambient temperature:	-25°C ... +60°C
Storage and transport temperature:	-40°C ... +85°C
Protection class:	Enclosure: IP 40, Terminals: IP 20, Wiring compartment: IP 54
Air clearances and creepage distances to IEC/EN 60664-1:	4 kV/2 (basic insulation)
EMC rating:	to EMC Directive
Electrical data:	
Contact resistance in new state:	max. 100 mΩ
Power consumption:	max. 3.2 W / 7.1 VA 3 W, plus signalling outputs
Rated operating voltage U _e :	24 VDC -15% / +20%, residual ripple max. 10% 24 VAC -15% / +10%
Frequency range:	50 Hz / 60 Hz
Max. fuse rating of the operating voltage:	internal electronic fuse, tripping current F1: > 2.5 A; tripping current F2: > 50 mA (S11-S31) / 800 mA (X4)
Current and voltage at the control circuits:	S11, S12, S21, S22, S31, S32: 24 VDC, 10 mA X1, X2: 24 VDC, start impulse 350 mA / 15 ms X3, X4: 24 VDC, start impulse 130 mA / 80 ms X4, X5: 24 VDC, start impulse 140 mA / 15 ms
Monitored inputs:	
Cross-wire detection:	optional
Wire breakage detection:	Yes
Earth leakage detection:	Yes
Number of NO contacts:	0
Number of NC contacts:	2
Conduction resistance:	max. 40 Ω

Outputs:	
Number of safety contacts:	5
Number of auxiliary contacts:	0
Number of signalling outputs:	1
Switching capacity of the safety contacts:	13-14, 23-24, 33-34 (STOP 0): max. 250 V, 8 A ohmic (inductive in case of suitable protective wiring); AC-15: 230 VAC / 6 A, DC-13: 24 VDC / 6 A; residual current at ambient temperature up to 45°C: 18 A / 55°C: 15 A / 60°C: 12 A 47-48, 57-58 (STOP 1): max. 250 V, 6 A ohmic (inductive in case of suitable protective wiring); AC-15: 230 VAC / 3 A, DC-13: 24 VDC / 2 A; residual current at ambient temperature up to 45°C: 12 A / 55°C: 10 A / 60°C: 8 A
Switching capacity of the signalling outputs:	Y1-Y3: 24 VDC / 100 mA, residual current: 200 mA
Switching capacity of the auxiliary contacts:	61-62: 24 VDC / 2 A
Fuse rating of the safety contacts:	STOP 0: 8 A slow blow STOP 1: 6,3 A slow blow
Fuse rating of the signalling outputs:	500 mA (internal electronic fuse F3)
Recommended fuse for the auxiliary contacts:	2 A slow blow
Utilisation category to EN 60947-5-1:	AC-15, DC-13
Dimensions (H/W/D):	100 mm × 45 × 121 mm
The data specified in this manual is applicable when the component is operated with rated operating voltage $U_e \pm 0\%$.	

2.5 Safety classification

Standards:	EN ISO 13849-1, IEC 61508, EN 60947-5-1
PL:	Stop 0: up to e Stop 1: up to d
Control category:	Stop 0: up to 4 Stop 1: up to 3
DC:	Stop 0: 99% (high) Stop 1: > 60% (low):
CCF:	> 65 points
SIL:	Stop 0: up to 3 Stop 1: up to 2
Service life:	20 years
B_{10d} value (for one channel):	20%: 20,000,000 40%: 7,500,000 60%: 2,500,000 80%: 1,000,000 100%: 400,000

$$MTTF_d = \frac{B_{10d}}{0,1 \times n_{op}} \quad n_{op} = \frac{d_{op} \times h_{op} \times 3600 \text{ s/h}}{t_{cycle}}$$

For an average annual demand rate of $n_{op} = 126,720$ cycles per year, Performance Level PL e can be obtained at maximum load.

n_{op} = average number of activations per year
 d_{op} = average number of operating days per year
 h_{op} = average number of operating hours per day
 t_{cycle} = average demand rate of the safety function in s
(e.g. 4 × per hour = 1 × per 15 min. = 900 s)

(Specifications can vary depending on the application-specific parameters h_{op} , d_{op} and t_{cycle} as well as the load.)

3 Mounting

3.1 General mounting instructions

Mounting: snaps onto standard DIN rails to EN 60715.

Snap the bottom of the enclosure slightly tilted forwards in the DIN rail and push up until it latches in position.

3.2 Dimensions

All measurements in mm.

Device dimensions (H/W/D): 100 × 45 × 121 mm
with plugged-in terminals: 120 × 45 × 121 mm

4 Electrical connection

4.1 General information for electrical connection



The electrical connection may only be carried out by authorised personnel in de-energised condition.

Wiring examples: see appendix

5 Operating principle and settings

LED functions

- K1: Status channel 1
- K2: Status channel 2
- K3/K4: Status delayed enabling circuit (LED is ON, when the delayed enabling circuits 47-48, 57-58 are closed)
- U_B : Status operating voltage (LED is on, when the operating voltage on the terminals A1-A2 is ON)
- U_i : Status internal operating voltage (LED is on, when the operating voltage on the terminals A1-A2 is ON and the fuse has not been triggered)

Terminal description (see Fig. 1)

Voltages:	
A1	+24 VDC / 24 VAC
A1.1	+24 VDC / 24 VAC
A2	0 VDC / 24 VAC
Inputs:	
S11-S12	Input channel 1 (+)
S11-S22	Input channel 2 (+)
S21-S22	Input channel 2 (-) (with cross-wire short detection)
S12-S32	Input channel 2 (-) (without cross-wire short detection)
S31	+24 VDC
Out-puts:	
13-14	First safety enabling circuit (stop 0)
23-24	Second safety enabling circuit (stop 0)
33-34	Third safety enabling circuit (stop 0)
47-48	Fourth safety enabling circuit (stop 1)
57-58	Fifth safety enabling circuit (stop 0)
Start:	
X1-X2	Feedback circuit
X3-X4	Feedback circuit and external reset (monitored)
X4-X5	Automatic start
Y1 + Y2	Signalling output channel 1 and 2
Y3	Fuse F3
RT	Reset timer

Opening the front cover (see Fig. 2)

- To open the front cover, insert a slot screwdriver in the top and bottom cover notch and gently lift it.
- When the front cover is open, the electrostatic discharge requirements must be respected and observed.
- After the setting, the front cover must be fitted back in position.
- The set drop-out delay must be entered on the front cover.

 Only touch the components after electrical discharge!

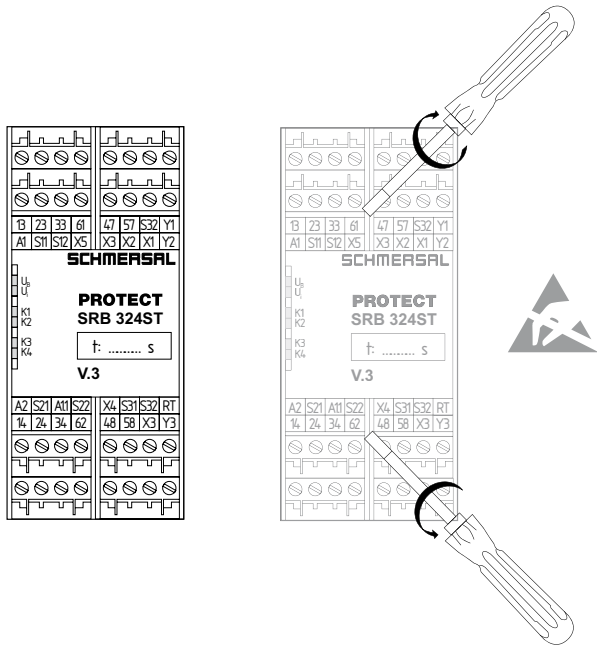

Fig. 1 Fig. 2

Time setting (see Fig. 3 and 4)

DIP switch settings:

- The DIP switches are located underneath the front cover of the safety-monitoring module (see Fig. 3 and 4).
- Both DIP switches SW 1 (channel 1) and SW 2 (channel 2) must be set identically.
- The DIP switches can be set when the operating voltage is on; however, in order for the setting to be saved in the SRB 324ST, the voltage supply must be interrupted for approx. 3 seconds.

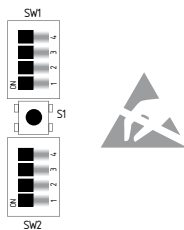



Fig. 3

 New adjustable drop-out delays and cross-wire short monitoring for version V.3! See Fig. 4. Tolerance $\pm 2\%$

















DIP switch setting	Drop-out delay	DIP switch setting	Drop-out delay
	<0,1 s		5.0 s
	0.5 s		8.5 s
	1.0 s		10.0 s
	1.5 s		12.0 s
	2.0 s		15.0 s
	2.5 s		20.0 s
	3.0 s		25.0 s
	4.0 s		30.0 s

Fig. 4

Resetting the hybrid fuse

- The hybrid fuse of the safety-monitoring module can be reset by switching the operating voltage off and back on or by actuating button S1.
- Button S1 is located underneath the front cover of the safety-monitoring module (see Fig. 2 and 3).

5.1 Notes

Reduction of the delay time (see Fig. 5)

- The drop-out delay time can be terminated prematurely via the input RT.
- The drop-out delay can be prematurely terminated by supplying terminal RT with +24V (rising edge).
- The +24V is made available either at the terminals S11, S31, X4 or A1.1

Delayed enabling circuits (see Fig. 6)

- The drop-out delay of the safety enabling circuits 47-48 and 57-58 can be set within the range of 0...30 seconds by means of DIP switches. The DIP switches are located underneath the front cover of the safety-monitoring module.
- The safety enabling circuits 47-48 and 57-58 meet STOP category 1 to EN 60204-1.
- The safety enabling circuits 13-14, 23-24 and 33-34 meet STOP category 0 to EN 60204-1.

Signalling outputs (see fig. 7)

- The input circuits are signalled through the signalling outputs Y1 (channel 1) and Y2 (channel 2).
- The hybrid fuse of the safety-monitoring module can be reset by switching the operating voltage off and back on or by actuating button S1.
- Button S1 is located underneath the front cover of the safety-monitoring module.
- The status of the hybrid fuse is signalled through signalling output Y3. If the hybrid fuse is not activated, Y3 is supplied with operating voltage.

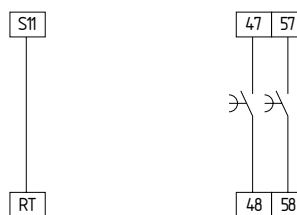

Fig. 5 Fig. 6

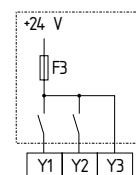

Fig. 7

5.2 Setting report SRB 324ST V.3

This report regarding the setting of the device must be completed accordingly by the customer and enclosed in the technical manual of the machine.

The setting report must be available whenever a safety check is performed.

Company: _____

The safety-monitoring module is used in the following machine:

Machine n° _____ Machine type _____ Module n° _____

Set drop-out delay: _____

Set on (date) _____ Signature of the responsible person _____

6 Set-up and maintenance

6.1 Functional testing

The safety function of the safety-monitoring module must be tested. The following conditions must be previously checked and met:

1. Correct fixing
2. Check the integrity of the cable entry and connections
3. Check the safety-monitoring module's enclosure for damage.
4. Check the electrical function of the connected sensors and their influence on the safety-monitoring module and the downstream actuators

6.2 Maintenance

A regular visual inspection and functional test, including the following steps, is recommended:

1. Check the correct fixing of the safety-monitoring module
2. Check the cable for damages
3. Check electrical function

Damaged or defective components must be replaced.

7 Disassembly and disposal

7.1 Disassembly

The safety-monitoring module must be disassembled in a de-energised condition only.

7.2 Disposal

The safety-monitoring module must be disposed of in an appropriate manner in accordance with the national prescriptions and legislations.

8 Appendix

8.1 Wiring examples

Dual-channel control, shown for a guard door monitor; with two contacts A and B, where at least one is a positive break contact; with external reset button (R)

- Relay outputs: Suitable for 2 channel control, for increase in capacity or number of contacts by means of contactors or relays with positive-guided contacts.
- The control system recognises wire-breakage, earth faults and cross-wire shorts in the monitoring circuit.
- F2 = hybrid fuse 50 mA / 800 mA
- ⊕ = Feedback circuit

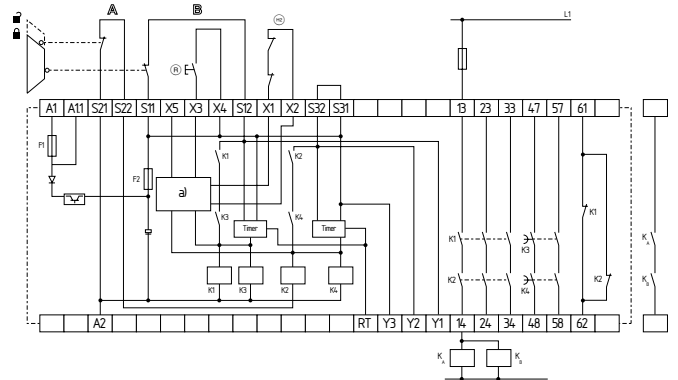

Fig. 8
a) channel control

8.2 Start configuration

External reset button (with edge detection) (see Fig. 9)

- The external reset button is integrated as shown.
- The safety-monitoring module is activated by the reset (after release) of the reset button (= detection of the falling edge). Faults in the reset button, e.g. welded contacts or manipulations which could lead to an inadvertent restart, are detected in this configuration and will result in an inhibition of the operation.
- An output with 24 V / 250 mA must be made available by the control system. This output must be connected to X3. X3 must be enabled for at least 100 ms (HIGH). The safety-monitoring module is activated by the output being switched off (LOW).

Automatic start (see Fig. 10)

- The automatic start is programmed by connecting the feedback circuit to the terminals. If the feedback circuit is not required, establish a bridge.
- **Caution:** Not admitted without additional measure due to the risk of gaining access by stepping behind!
- **Caution:** within the meaning of EN IEC 60204-1 paragraph 9.2.5.4.2 and 10.8.3, the operating mode "automatic start" is only restrictedly admissible. In particular, any inadvertent restart of the machine must be prevented by other suitable measures.

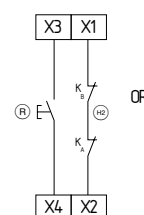

Fig. 9
a) Controller

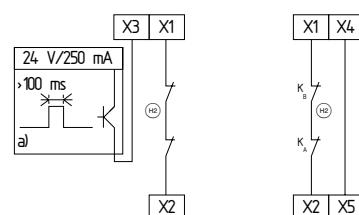

Fig. 10

8.3 Sensor configuration

Dual-channel control of a safety-related electronic (micro-processor-based) safety guard with p-type transistor outputs e.g. AOPD's to EN IEC 61496 (see Fig. 11)

- Wire breakage and earth leakage in the control circuits are detected.
- Cross-wire shorts between the control circuits are usually detected by the safety guards. The safety-monitoring module therefore is not equipped with a cross-wire short detection here.
- Control category: 3 to EN 954-1
- If cross-wire shorts in the control circuits are detected by the safety guard:
 - control category 4 to EN 954-1:1997
 - control category 4 – PL e to DIN EN ISO 13849-1 possible.

Single-channel emergency stop circuit with command devices to DIN EN ISO 13850 (EN 418) and EN 60947-5-5 (Fig. 12)

- Wire breakage and earth leakage in the control circuits are detected.
- Control category: 2 to EN 954-1
- Category 3 – PL d to DIN EN 13849-1 possible

Dual-channel emergency stop circuit with command devices to DIN EN ISO 13850 (EN 418) and EN 60947-5-5 (Fig. 13)

- Wire breakage and earth leakage in the control circuits are detected.
- Cross-wire shorts between the control circuits are not detected.
- Control category: 3 to EN 954-1
- Control category 4 – PL e to DIN EN 13849-1 possible (with protective wiring).

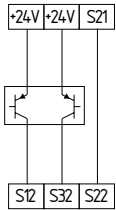

Fig. 11

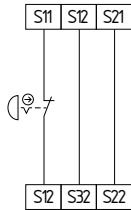

Fig. 12

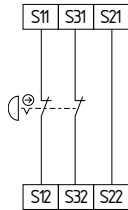

Fig. 13

Dual-channel emergency stop circuit with command devices to DIN EN ISO 13850 (EN 418) and EN 60947-5-5 (Fig. 14)

- Wire breakage and earth leakage in the control circuits are detected.
- Cross-wire shorts between the control circuits are detected.
- Control category: 4 to EN 954-1
- Category 4 – PL "e" to DIN EN ISO 13849-1 possible

Single-channel guard door monitoring circuit with interlocking devices to EN 1088 (Fig. 15)

- At least one contact with positive break required
- Wire breakage and earth leakage in the control circuits are detected.
- Control category: 2 to EN 954-1
- Category 2 – PL d to DIN EN ISO 13849-1 possible

Dual-channel guard door monitoring circuit with interlocking device to EN 1088 (Fig. 16)

- With at least one positive-break position switch
- Wire breakage and earth leakage in the control circuits are detected.
- Cross-wire shorts between the control circuits are not detected.
- Control category: 3 to EN 954-1
- Control category 4 – PL e to DIN EN 13849-1 possible (with protective wiring).

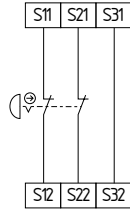

Fig. 14

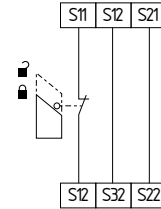

Fig. 15

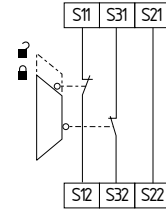

Fig. 16

Dual-channel guard door monitoring circuit with interlocking device to EN 1088 (Fig. 17)

- With at least one positive-break position switch
- Wire breakage and earth leakage in the control circuits are detected.
- Cross-wire shorts between the control circuits are detected.
- Control category: 4 to EN 954-1
- Category 4 – PL e to DIN EN ISO 13849-1 possible

Dual-channel control of magnetic safety switches to EN 60 947-5-3 (see Fig. 18)

- Wire breakage and earth leakage in the control circuits are detected.
- Cross-wire shorts between the control circuits are not detected.
- Control category: 3 to EN 954-1
- Category 3 – PL "e" to DIN EN ISO 13849-1 possible

Dual-channel control of magnetic safety switches to EN 60 947-5-3 (see Fig. 19)

- Wire breakage and earth leakage in the control circuits are detected.
- Cross-wire shorts between the control circuits are detected.
- Control category: 3 to EN 954-1
- Category 3 – PL "e" to DIN EN ISO 13849-1 possible

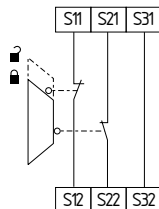

Fig. 17

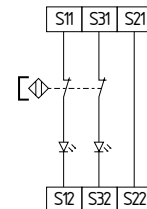

Fig. 18

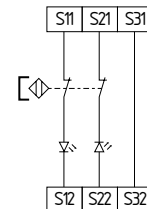

Fig. 19



The connection of magnetic safety switches to the SRB 324ST safety-monitoring module is only admitted when the requirements of the standard EN 60947-5-3 are observed.

As the technical data are regarded, the following minimum requirements must be met:

- switching capacity: min. 240 mW
- switching voltage: min. 24 VDC
- switching current: min. 10 mA



For example, the following safety sensors meet the requirements:

- BNS 33-02z-2187, BNS 33-02zG-2187
- BNS 260-02z, BNS 260-02zG
- BNS 260-02-01z, BNS 260-02-01zG



When sensors with LED are wired in the control circuit (protective circuit), the following rated operating voltage must be observed and respected:

- 24 VDC with a max. tolerance of -5 %/+20 %
- 24 VAC with a max. tolerance of -5 %/+10 %

Otherwise availability problems could occur, especially in series-wired sensors, where a voltage drop in the control circuit is triggered by LED's for instance.

8.4 Actuator configuration

Single-channel control with feedback circuit (Fig. 20)

- Suitable for increase in capacity or number of contacts by means of contactors or relays with positive-guided contacts.
- HE = Feedback circuit: if the feedback circuit is not required, establish a bridge.

Dual-channel control with feedback circuit (Fig. 21)

- Suitable for increase in capacity or number of contacts by means of contactors or relays with positive-guided contacts.
- HE = Feedback circuit: if the feedback circuit is not required, establish a bridge.

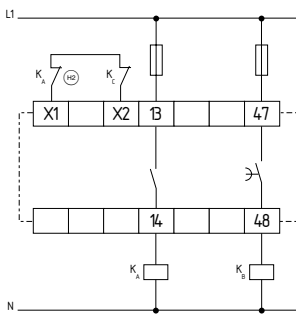

Fig. 20

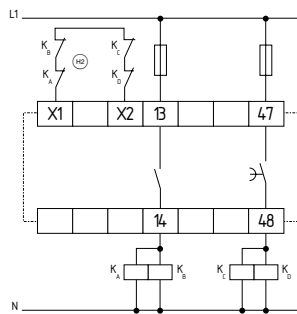

Fig. 21

Differential control with feedback circuit (see Fig. 22)

- Suitable for increase in capacity or number of contacts by means of contactors or relays with positive-guided contacts.
- HE = Feedback circuit: if the feedback circuit is not required, establish a bridge. If the enabling circuit of the controller must be equipped with its own feedback circuit, this circuit must be integrated as shown in the wiring example "dual-channel control with feedback circuit" (see there).

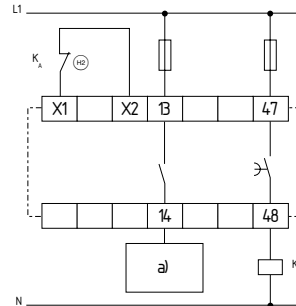



Fig. 22
a) Enabling signal controller

8.5 EC Declaration of conformity

	
<h2>EC Declaration of conformity</h2>	
Translation of the original declaration of conformity valid as of December 29, 2009	Elan Schaltelemente GmbH & Co. KG Im Ostpark 2 · 35435 Wettenberg Germany Internet: www.elan.de
We hereby certify that the hereafter described safety components both in its basic design and construction conforms to the applicable European Directives.	
Name of the safety component:	SRB 324ST V.3
Description of the safety component:	Safety-monitoring module for emergency stop circuits, guard door monitoring, magnetic safety switches and AOPD's
Harmonised EC-Directives:	2006/42/EC EC-Machinery Directive 2004/108/EC EMC-Directive
Person authorized for the compilation of the technical documentation:	Ulrich Loss Mödinghofe 30 42279 Wuppertal
Notified body, which approved the full quality assurance system, referred to in Appendix X, 2006/42/EC:	TÜV Rheinland Industrie Service GmbH Alboinstraße 56 12103 Berlin ID n°: 0035
Place and date of issue:	Wuppertal, October 6, 2009
SRB324STV.3-B-EN	
	Authorised signature Heinz Schmersal Managing Director



Note

The currently valid declaration of conformity can be downloaded from the internet at www.schmersal.net.



Elan Schaltelemente GmbH & Co. KG
Im Ostpark 2, D - 35435 Wettenberg
Postfach 1109, D - 35429 Wettenberg

Telefon: +4 9 (0)6 41 9848-0
Telefax: +49 (0)641 9848-420
E-Mail: info-elan@schmersal.com
Internet: www.elan.de