

# **Agilent U2600A Series USB Isolated Digital Input/Output Modules**

## **User's Guide**



**Agilent Technologies**

# Notices

© Agilent Technologies, Inc., 2007, 2009

No part of this manual may be reproduced in any form or by any means (including electronic storage and retrieval or translation into a foreign language) without prior agreement and written consent from Agilent Technologies, Inc. as governed by United States and international copyright laws.

## Manual Part Number

U2651-90011

## Edition

Third Edition, September 1, 2009

Printed in Malaysia

Agilent Technologies, Inc.  
Bayan Lepas Free Industrial Zone,  
11900 Penang, Malaysia

## Trademark Acknowledgements

Pentium is a U.S. registered trademark of Intel Corporation.

Microsoft, Visual Studio, Windows, and MS Windows are trademarks of Microsoft Corporation in the United States and/or other countries.

## Warranty

**The material contained in this document is provided “as is,” and is subject to being changed, without notice, in future editions. Further, to the maximum extent permitted by applicable law, Agilent disclaims all warranties, either express or implied, with regard to this manual and any information contained herein, including but not limited to the implied warranties of merchantability and fitness for a particular purpose. Agilent shall not be liable for errors or for incidental or consequential damages in connection with the furnishing, use, or performance of this document or of any information contained herein. Should Agilent and the user have a separate written agreement with warranty terms covering the material in this document that conflict with these terms, the warranty terms in the separate agreement shall control.**

## Technology Licenses

The hardware and/or software described in this document are furnished under a license and may be used or copied only in accordance with the terms of such license.

## Restricted Rights Legend

U.S. Government Restricted Rights. Software and technical data rights granted to the federal government include only those rights customarily provided to end user customers. Agilent provides this customary commercial license in Software and technical data pursuant to FAR 12.211 (Technical Data) and 12.212 (Computer Software) and, for the Department of Defense, DFARS 252.227-7015 (Technical Data - Commercial Items) and DFARS 227.7202-3 (Rights in Commercial Computer Software or Computer Software Documentation).

## Safety Notices

### CAUTION

A **CAUTION** notice denotes a hazard. It calls attention to an operating procedure, practice, or the like that, if not correctly performed or adhered to, could result in damage to the product or loss of important data. Do not proceed beyond a **CAUTION** notice until the indicated conditions are fully understood and met.

---

### WARNING

A **WARNING** notice denotes a hazard. It calls attention to an operating procedure, practice, or the like that, if not correctly performed or adhered to, could result in personal injury or death. Do not proceed beyond a **WARNING** notice until the indicated conditions are fully understood and met.

---

## Safety Information

The following general safety precautions must be observed during all phases of this instrument. Failure to comply with these precautions or with specific warnings elsewhere in this manual violates safety standards of design, manufacture, and intended use of the instrument. Agilent Technologies, Inc. assumes no liability for the customer's failure to comply with these requirements.

### Regulatory Markings

---



The CE mark is a registered trademark of the European Community. This CE mark shows that the product complies with all the relevant European Legal Directives.

---

#### ICES/NMB-001

ICES/NMB-001 indicates that this ISM device complies with Canadian ICES-001.



















The CSA mark is a registered trademark of the Canadian Standards Association. A CSA mark with the indicators "C" and "US" means that the product is certified for both the U.S. and Canadian markets, to the applicable American and Canadian standards.



The C-tick mark is a registered trademark of the Spectrum Management Agency of Australia. This signifies compliance with the Australian EMC Framework regulations under the terms of the Radio Communications Act of 1992.

---

## Safety Symbols

	Direct current
	Alternating current
	Both direct and alternating current
	Three-phase alternating current
	Earth (ground) terminal
	Protective conductor terminal
	Frame or chassis terminal
	Equipotentiality
	On (Supply)
	Off (Supply)
	Equipment protected throughout by double insulation or reinforced insulation
	Caution, risk of electric shock
	Caution, hot surface
	Caution, risk of danger (See note.)
	In position of a bi-stable push control
	Out position of a bi-stable push control

## General Safety Information

### WARNING

- Do not use the device if it is damaged. Before you use the device, inspect the case. Look for cracks or missing plastic. Do not operate the device around explosive gas, vapor or dust.
  - Do not apply more than the rated voltage (as marked on the device) between terminals, or between terminal and external ground.
  - Always use the device with the cables provided.
  - Observe all markings on the device before connecting to the device.
  - Turn off the device and application system power before connecting to the I/O terminals.
  - When servicing the device, use only specified replacement parts.
  - Do not operate the device with the removable cover removed or loosened.
  - Do not connect any cables and terminal block prior to performing self-test process.
  - Use only the power adapter supplied by the manufacturer to avoid any unexpected hazards.
- 

### CAUTION

- Do not load the output terminals above the specified current limits. Applying excessive voltage or overloading the device will cause irreversible damage to the circuitry.
  - Applying excessive voltage or overloading the input terminal will damage the device permanently.
  - If the device is used in a manner not specified by the manufacturer, the protection provided by the device may be impaired.
  - Always use dry cloth to clean the device. Do not use ethyl alcohol or any other volatile liquid to clean the device.
  - Do not permit any blockage of the ventilation holes of the device.
-

## Waste Electrical and Electronic Equipment (WEEE) Directive 2002/96/EC

This instrument complies with the WEEE Directive (2002/96/EC) marking requirement. This affixed product label indicates that you must not discard this electrical/electronic product in domestic household waste.

Product Category:

With reference to the equipment types in the WEEE directive Annex 1, this instrument is classified as a “Monitoring and Control Instrument” product.

The affixed product label is shown as below:

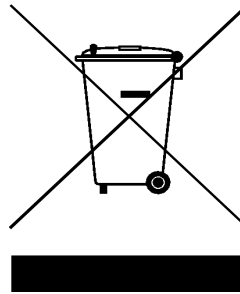

### **Do not dispose in domestic household waste**

To return this unwanted instrument, contact your nearest Agilent office, or visit:

<http://www.agilent.com/environment/product>

for more information.

## In This Guide...

### **1 Getting Started**

This chapter provides an overview of the U2600A series USB isolated digital input/output (DIO) modules, product outlook and product layout. This chapter also contains instructions on how to get started with the U2600A series isolated DIO modules that begins from system requirements checking to installations of hardware and software.

### **2 Connector Pins Configuration**

This chapter describes the connector pins configuration of all the U2600A series isolated DIO modules.

### **3 Features and Functions**

This chapter includes information for better understanding on the features and functions of the U2600A series isolated DIO modules. This includes the operations of the digital input/output, group function, interrupt function, and trigger function.

### **4 Product Characteristics and Specifications**

This chapter specifies the characteristics, and specifications of the U2600A series DIO modules.

### **5 Dismantle Procedures**

This chapter describes the step-by-step disassemble procedures and list the available replacement parts for U2600A series DIO modules.



**Agilent Technologies**

**DECLARATION OF CONFORMITY**

According to EN ISO/IEC 17050-1:2004



**Manufacturer's Name:** Agilent Technologies Microwave Products (M) Sdn. Bhd  
**Manufacturer's Address:** Bayan Lepas Free Industrial Zone,  
11900, Bayan Lepas, Penang, Malaysia

**Declares under sole responsibility that the product as originally delivered:**

**Product Name:** Agilent U2600A Series USB Isolated Digital Input/Output Modules  
**Models Number:** U2651A, U2652A, U2653A  
**Product Options:** This declaration covers all options of the above product(s)

**complies with the essential requirements of the following applicable European Directives, and carries the CE marking accordingly:**

Low Voltage Directive (2006/95/EC)  
EMC Directive (2004/108/EC)

**and conforms with the following product standards:**

EMC	Standard	Limit
	IEC 61326:2002 / EN 61326:1997+A1:1998+A2:2001+A3:2003	
	CISPR 11:1990 / EN55011:1990	Class A Group 1
	IEC 61000-4-2:1995 / EN 61000-4-2:1995	4 kV CD, 8 kV AD
	IEC 61000-4-3:1995 / EN 61000-4-3:1996	3 V/m, 80-1000 MHz
	IEC 61000-4-4:1995 / EN 61000-4-4:1995	0.5 kV signal lines, 1 kV power lines
	IEC 61000-4-5:1995 / EN 61000-4-5:1995	0.5 kV line-line, 1 kV line-ground
	IEC 61000-4-6:1996 / EN 61000-4-6:1996	3 V, 0.15-80 MHz
	IEC 61000-4-11:1994 / EN 61000-4-11:1994	1 cycle / 100%

Canada: ICES-001:2004  
Australia/New Zealand: AS/NZS CISPR11:2004

The product was tested in a typical configuration with Agilent Technologies test systems.

**Safety** IEC 61010-1:2001 / EN 61010-1:2001  
Canada: CAN/CSA-C22.2 No. 61010-1-04  
USA: ANSI/UL 61010-1:2004



**This DoC applies to above-listed products placed on the EU market after:**

19 Oct 2007  
Date

**Mack Soh**  
Quality Manager

For further information, please contact your local Agilent Technologies sales office, agent or distributor, or Agilent Technologies Deutschland GmbH, Herrenberger Straße 130, 71034 Böblingen, Germany.

## Product Regulations

### EMC

IEC 61326-1:2002 / EN 61326-1:1997+A1:1998+A2:2001+A3:2003

CISPR 11:1990 / EN 55011:1990 – Group 1 Class A

IEC 61000-4-2:1995 / EN 61000-4-2:1995 (ESD 4kV CD, 8kV AD)

IEC 61000-4-3:1995 / EN 61000-4-3:1996 (3V/m, 80% AM)

IEC 61000-4-4:1995 / EN 61000-4-4:1995 (EFT 0.5kV line-line, 1kV line-earth)

IEC 61000-4-5:1995 / EN 61000-4-5:1995 (Surge 0.5kV line-line, 1kV line-earth)

IEC 61000-4-6:1996 / EN 61000-4-6:1996 (3V, 0.15-80 MHz, 80% AM, power line)

IEC 61000-4-11:1994 / EN 61000-4-11:1994 (Dips 1 cycle, 100%)

Canada: ICES-001:2004

Australia/New Zealand: AS/NZS CISPR11:2004

### Performance Criteria

A

A

B

A

A

B

**Safety** IEC 61010-1:2001 / EN 61010-1:2001

Canada: CAN/CSA-C22.2 No. 61010-1-04

USA: ANSI/UL 61010-1:2004

### Additional Information:

The product herewith complies with the essential requirements of the Low Voltage Directive 2006/95/EC and the EMC Directive (2004/108/EC) and carries the CE Marking accordingly (European Union).

### <sup>1</sup>Performance Criteria:

A Pass - Normal operation, no effect.

B Pass - Temporary degradation, self recoverable.

C Pass - Temporary degradation, operator intervention required.

D Fail - Not recoverable, component damage.

N/A – Not applicable due to the product is a battery operated device

### Models Description:

U2651A: Isolated 32-bit Digital Input (DI) and 32-bit Digital Output (DO).

U2652A: Isolated 64-bit Digital Input (DI).

U2653A: Isolated 64-bit Digital Output (DO).

### Notes:

#### Regulatory Information for Canada

ICES/NMB-001:2004

This ISM device complies with Canadian ICES-001.

Cet appareil ISM est conforme à la norme NMB-001 du Canada.

#### Regulatory Information for Australia/New Zealand

This ISM device complies with Australian/New Zealand AS/NZS CISPR11:2004

 N10149



# Contents

<b>1</b>	<b>Getting Started</b>	
	Introduction	2
	Product Overview	3
	Product outlook	3
	Product dimension	4
	Terminal Block Overview	5
	Standard Purchase Items Checklist	6
	Software Installation	7
	A. Check Your System Requirements	8
	B. Install the Agilent IO Libraries Suite	9
	C. Install the Hardware Driver	10
	D. Install the Agilent Measurement Manager	14
	E. Connect Your Device to the PC	17
	F. Launch Your Agilent Measurement Manager	19
	L-Mount Kit Installation	20
	General Maintenance	22
	Additional Information	23
	Hardware verification	23
	Sample code	24
<b>2</b>	<b>Connector Pins Configuration</b>	
	Introduction	28
	Connector Pins Configuration for U2651A	29
	Connector Pins Configuration for U2652A	31
	Connector Pins Configuration for U2653A	33

	55-pin Connector (J1) Pins Configuration	35
<b>3</b>	<b>Features and Functions</b>	
	Digital Input/Output	38
	Isolated digital input channels	39
	Isolated digital output channels	40
	Virtual Port Group Function	43
	Interrupt Function	44
	Trigger Function	48
<b>4</b>	<b>Product Characteristics and Specifications</b>	
	Product Characteristics	58
	Product Specifications	59
	U2600A series DIO specifications	59
<b>5</b>	<b>Dismantle Procedures</b>	
	General Disassemble	62
	Mechanical disassemble	62
	Troubleshooting	66
	Self-Test Procedures	67

## List of Figures

- Figure 2-1 Connector in vertical view 28
- Figure 2-2 Connector in horizontal view 28
- Figure 2-3 Pins configuration for U2651A 29
- Figure 2-4 Pins configuration for U2652A 31
- Figure 2-5 Pins configuration for U2653A 33
- Figure 2-6 Connector (J1) 55-pin 35
- Figure 3-1 Isolated digital input bit through a photo coupler 39
- Figure 3-2 The maximum and minimum allowable input voltage at  $DI_{in}$  and  $DI_{COM}$  and the absolute voltage range for DIO to see a logic high 39
- Figure 3-3 Isolated digital output is switched on with load 41
- Figure 3-4 Isolated digital output is switched off with load 41
- Figure 3-5 Enabling the Interrupt Operation Register will allow it to send a signal, "1" to the Status Byte Register when either the logic level for bit 301 or bit 302 changes from "0" to "1". 44
- Figure 3-6 Flowchart for interrupt function operation 46
- Figure 3-7 Flowchart for trigger function operation 48

## List of Tables

Table 2-1	Pins legend for U2651A	30
Table 2-2	Pins legend for U2652A	32
Table 2-3	Pins legend for U2653A	34
Table 2-4	U2600A series J1 connector pin assignment	35
Table 2-5	U2600A series J1 connector legend	35
Table 3-1	Step-by-step descriptions for trigger function flowchart	49
Table 4-1	Digital input product specifications for U2600A series DIO (U2651A, U2652A, and U2653A)	59
Table 4-2	Digital output product specifications for U2600A series DIO (U2651A, U2652A, and U2653A)	59
Table 4-3	Power supply product specifications for U2600A series DIO (U2651A, U2652A, and U2653A)	60
Table 4-4	General product specifications for U2600A series DIO (U2651A, U2652A, and U2653A)	60



# 1 Getting Started

Introduction	2
Product Overview	3
Product outlook	3
Product dimension	4
Terminal Block Overview	5
Standard Purchase Items Checklist	6
Software Installation	7
A. Check Your System Requirements	8
B. Install the Agilent IO Libraries Suite	9
C. Install the Hardware Driver	10
D. Install the Agilent Measurement Manager	14
E. Connect Your Device to the PC	17
F. Launch Your Agilent Measurement Manager	19
L-Mount Kit Installation	20
General Maintenance	22
Additional Information	23
Hardware verification	23
Sample code	24

This chapter contains instructions on how to get started with U2600A series USB digital IO modules that begins from system requirements checking to installations of hardware and software to the launching of the Agilent Measurement Manager application software.



## Introduction

The Agilent U2600A series USB isolated digital input/output (DIO) are high performance and user friendly modules. It can be used as a standalone unit or as a modular unit. However, if used as modular unit, the module needs to be installed in the U2781A chassis. The U2600A series DIO consists of three models:

- U2651A: Isolated 32-bit DI and 32-bit DO
- U2652A: Isolated 64-bit DI
- U2653A: Isolated 64-bit DO

All three models have up to eight channels with 64-bit high density isolated DIO. The high digital I/O lines will increase the utility of the product and offer flexibility to the users.

The U2600A series DIO modules also equipped with high voltage isolation protection of up to 1250 Vrms. This feature can protect the instrument from severe damage to the internal circuit. The product recognizes a wide range of digital input (10 V to 24 V) as logic high. Therefore, it provides the users with more choices in choosing the external sensors with different DC output level.

In addition, the U2600A series DIO modules has high output driving capability of up to 35 V, which makes it capable to drive most actuators in industrial automation applications. With the Hi-speed USB connection of 480 Mbps, it is quick and easy to set up the instrument.

The U2600A series DIO modules are compatible with a wide range of Application Development Environments (ADE), such as Agilent VEE, LabVIEW, MATLAB and Microsoft Visual Studio. Besides, a special software, the Agilent Measurement Manager is bundled with the U2600A series DIO modules for free.

# Product Overview

## Product outlook

Top view

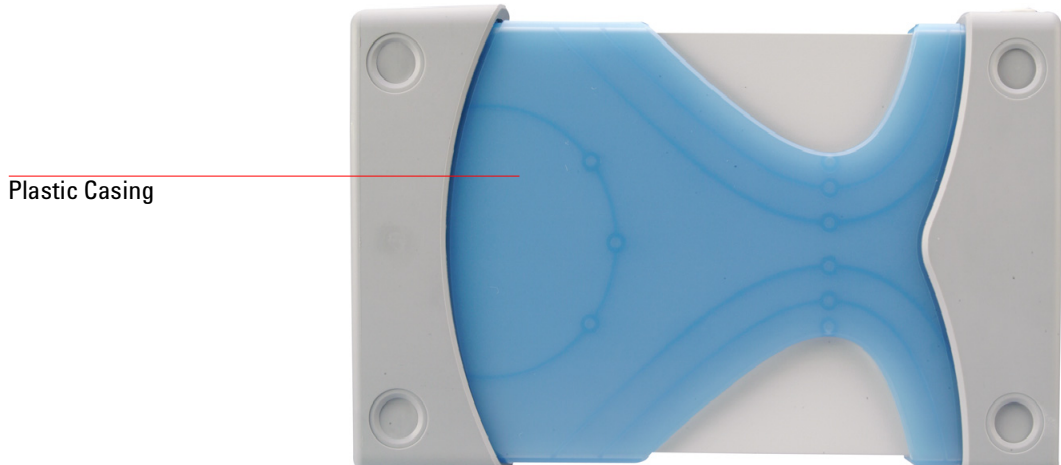

Front view

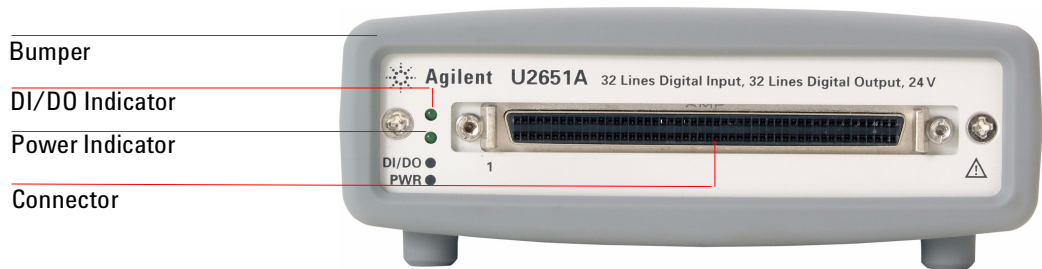

Rear view

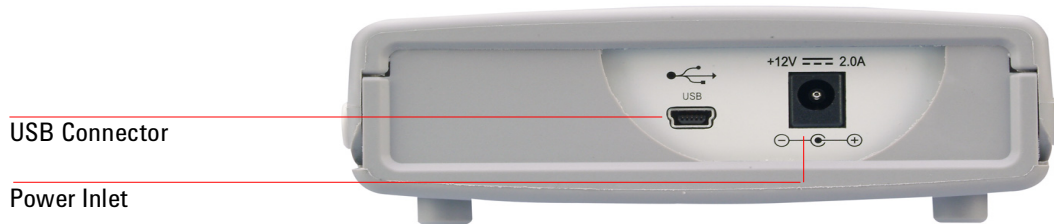

## Product dimension

With plastic casing

Top view

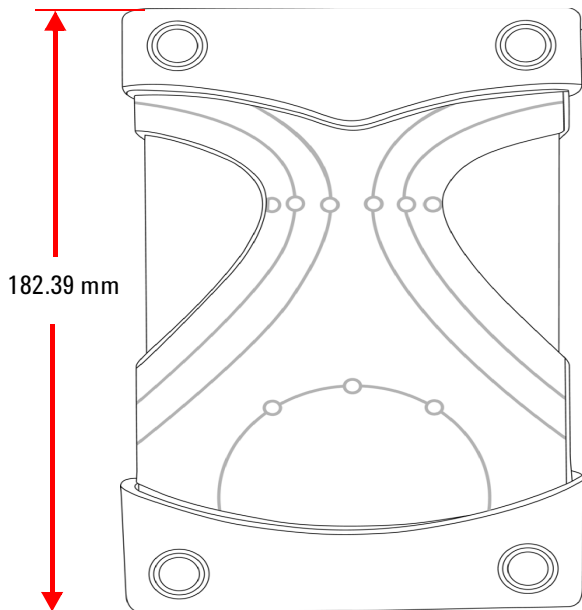

Front view

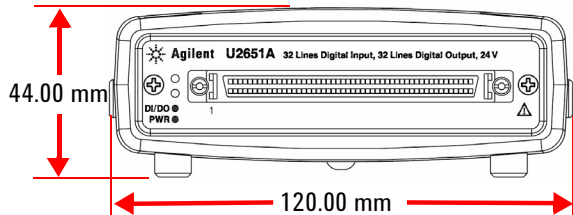

Without plastic casing

Top view

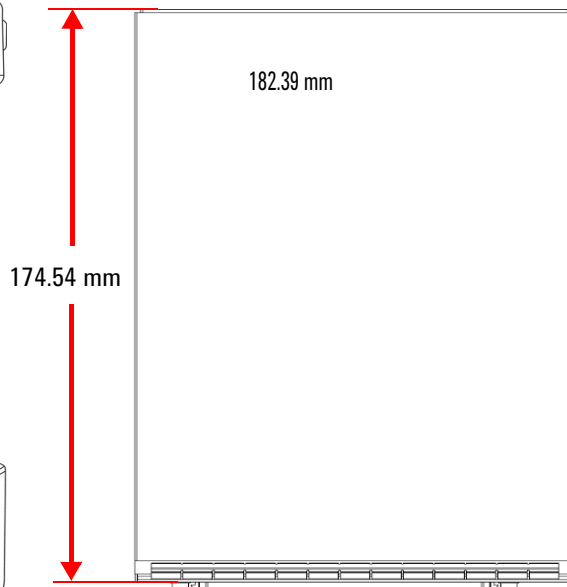

Front view

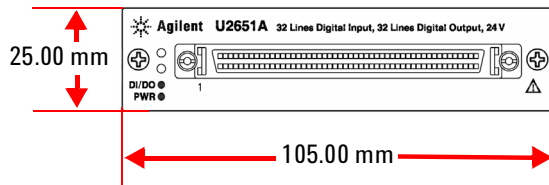

# Terminal Block Overview

Top view



Side view

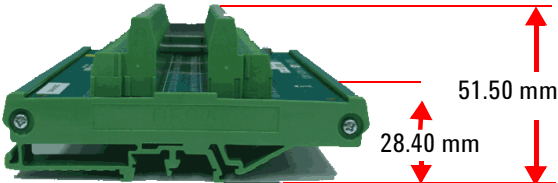

## Standard Purchase Items Checklist

Inspect and verify that you have all the following items upon your standard purchase of the U2600A series USB isolated DIO modules. If there are missing items, please contact the nearest Agilent Sales Office.

- ✓ DC power adapter
- ✓ Power cord
- ✓ USB extension cable
- ✓ L-Mount kit (used with Agilent U2781A modular instrument chassis)
- ✓ Agilent U2600A Series USB Isolated Digital IO Modules Quick Start Guide
- ✓ Agilent Measurement Manager for U2600A Series Quick Start Guide
- ✓ Agilent USB Modular Instrument Product Reference CD-ROM
- ✓ Agilent Automation-Ready CD (contains the Agilent IO Libraries Suite)
- ✓ Certificate of Calibration

**WARNING**

**Use only power adaptor provided by manufacturer to avoid unexpected hazard.**

---

## Software Installation

If you would like to use the U2600A series DIO modules with the Agilent Measurement Manager application software, follow the step-by-step instructions as shown in the following flowchart.

**NOTE**

- If you do not wish to specifically use the device with the Agilent Measurement Manager software but to use it on other ADE (e.g. Agilent VEE, LabVIEW, MATLAB or Microsoft Visual Studio), you can skip steps D and F in the following flowchart.
- You may require to install IVI-COM driver before using the U2600A series DIO modules with other ADE.

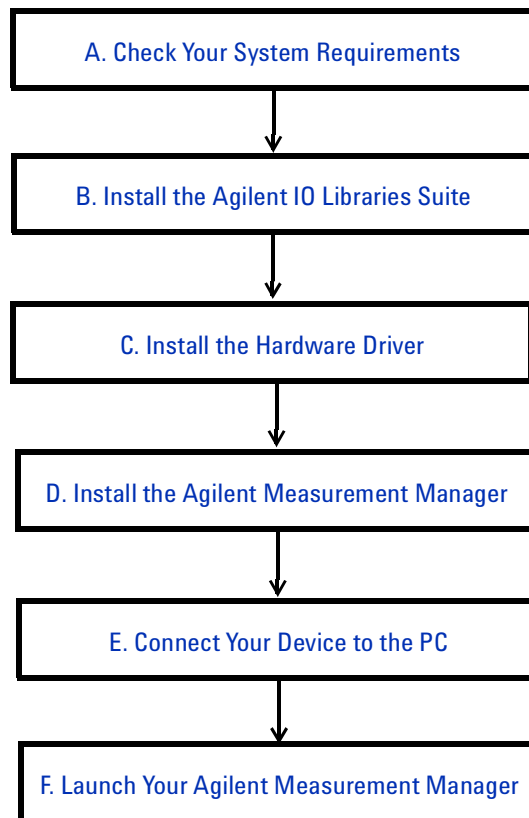

## A. Check Your System Requirements

Before installing the hardware driver and the Agilent Measurement Manager software, make sure your PC meets the following minimum system requirements for installation.

<b>Processor</b>	1.6 GHz Pentium® IV or higher
<b>Operating system</b>	Windows® XP Professional or Home Edition (Service Pack 1 or later), Windows® 2000 Professional (Service Pack 4 or later)
<b>Browser</b>	Microsoft® Internet Explorer 5.01 or higher
<b>Available RAM</b>	512 MB or higher recommended
<b>Hard disk space</b>	1 GB
<b>Prerequisite</b>	<ul style="list-style-type: none"><li>• Agilent IO Libraries Suite 14.2<sup>1</sup> or higher</li><li>• Agilent T&amp;M Toolkit 2.1 Runtime version<sup>2</sup></li><li>• Microsoft.NET Framework version 1.1 and 2.0<sup>2</sup></li><li>• Agilent T&amp;M Toolkit Redistributable Package 2.1 patch<sup>2</sup></li></ul>
<b>Video</b>	Super VGA (800x600) 256 colors or higher

1 Available in Agilent Automation-Ready CD.

2 Bundled with Agilent Measurement Manager application software installer

## B. Install the Agilent IO Libraries Suite

It is recommended to install the latest version of Agilent IO Libraries.

### NOTE

You must have Administrator privileges to install Agilent IO Libraries Suite and to run Connection Expert.

- 1 Verify that your PC meets the minimum system requirements. (See “A. Check Your System Requirements” on page 8.)
- 2 If you are upgrading to IO Libraries Suite from a previous version of IO Libraries, you must remove the instruments and interfaces listed below before you upgrade your software. This step is necessary in order for these devices to obtain the correct drivers to work with Agilent IO Libraries Suite.
  - a Disconnect any USB instruments from your PC.
  - b Disconnect any Agilent 82357 USB/GPIB interface converters from your PC.
  - c Disconnect any Agilent E8491 IEEE 1394 PC Link to VXI interfaces from your PC.
- 3 Close all other applications on your PC.
- 4 Insert the *Agilent Automation-Ready CD* with Agilent IO Libraries Suite into the CD-ROM drive of your PC. Wait a few seconds for the auto-run window to appear. If the auto-run window does not appear automatically,
  - Click **Start** > **Run...** and type <drive>:\autorun\auto.exe, where <drive> is your CD drive letter.
- 5 When the auto-run window appears, click **Install Software** once, and wait for the InstallShield Wizard to appear.
- 6 When the InstallShield Wizard appears, click **Next** > to begin the IO Libraries Suite software installation. Follow the instructions in the InstallShield Wizard and choose the options according to your preferences.
- 7 For more information to install the Agilent IO Libraries Suite, refer to *Agilent Technologies USB/LAN/GPIB Interfaces Connectivity Guide* available in the *Agilent Automation-Ready CD* with the file name called “connectivity\_guide.pdf”.

## C. Install the Hardware Driver

**NOTE**

- Ensure that the USB device is disconnected from your PC before installing the driver.
- Ensure that the Agilent IO Libraries Suite version 14.2 or higher is installed before proceeding.

- 1 Insert the *Agilent USB Modular Instrument Product Reference CD-ROM* into the CD-ROM drive of your PC.
- 2 The installer will automatically launch the Agilent Modular Products Installation Menu. Select **Hardware Driver** to begin the hardware driver installation.

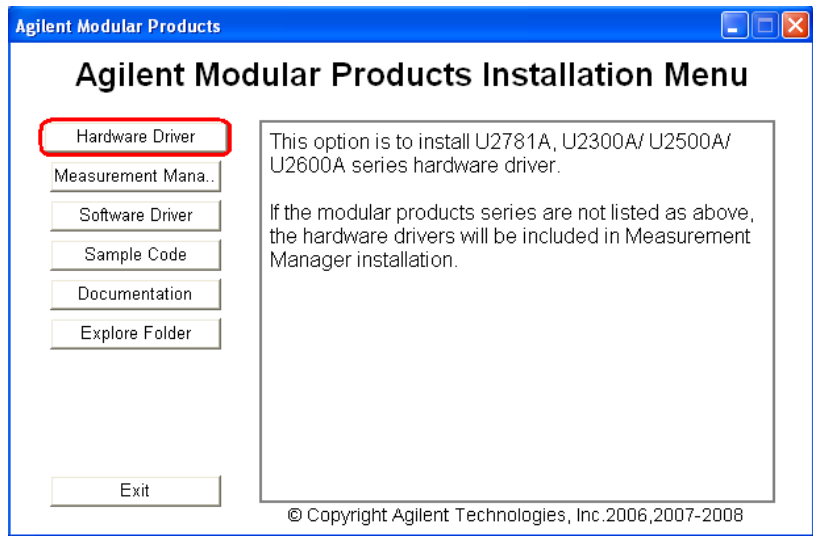

- 3 If the menu does not launch automatically, go to **Start > Run** (on the Windows Start menu) and type `<drive>:\Driver\Hardware\setup_hw.exe`, where `drive` is your CD-ROM drive. Click **OK** to begin installation.

- 4 The following dialog will appear. Click **Next >** to begin the installation.

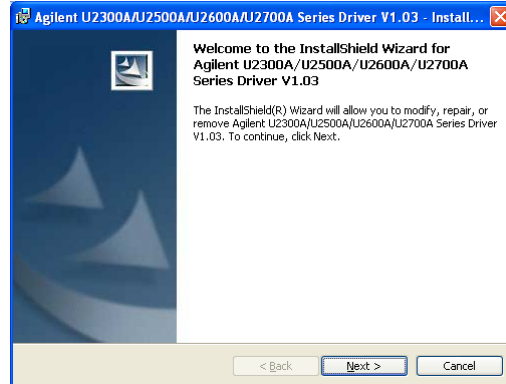

- 5 If you have previous hardware driver version, the dialog box will have the Modify, Repair and Remove options as shown below. Choose the option you like and click **Next >** to proceed.

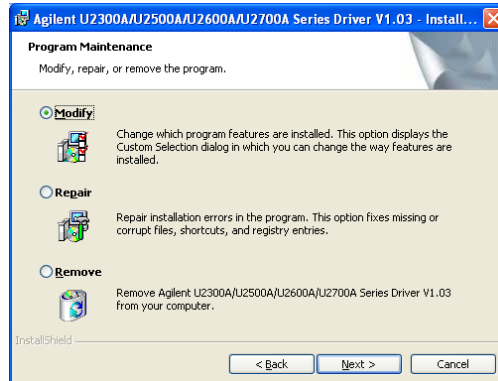

- 6 If you do not previously install any hardware driver, the following dialog box will be shown. Select **Typical** to install the all the features, otherwise select **Custom** to choose which program features you want to install. Click **Next >** to proceed.

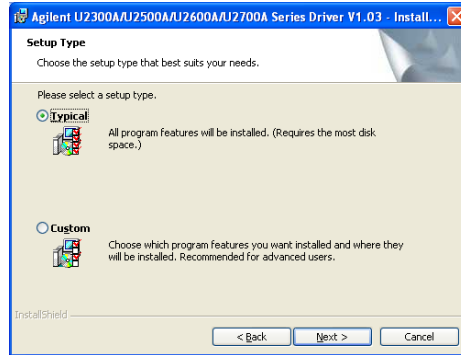

- 7 Choose the option you like and the following dialog will appear showing all the components that will be installed. Click **Install** to begin installation.

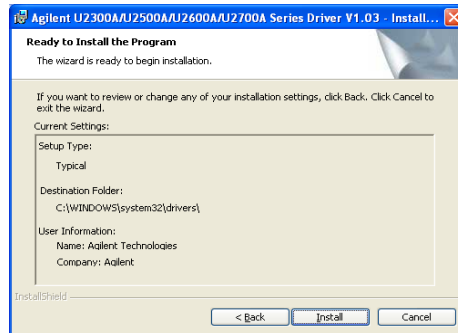

8 Click **Finish** when the installation has completed.

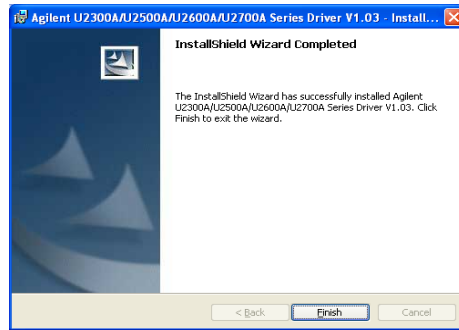

## D. Install the Agilent Measurement Manager

**NOTE**

- Ensure that the Agilent IO Libraries Suite version 14.2 or higher is installed before proceeding.
- You must have Administrator privileges to install Agilent IO Libraries Suite and to run Connection Expert.

- 1 Verify that you have the hardware driver installed.
- 2 Select **Measurement Manager** on the Agilent Modular Products Installation Menu to begin the installation.

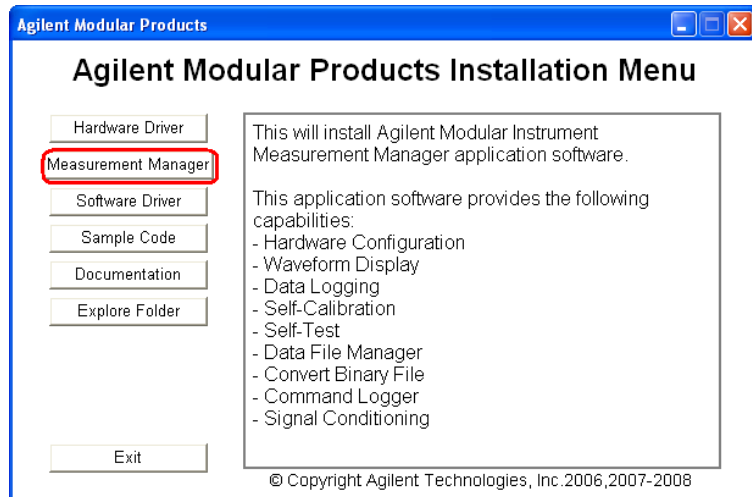

- 3 If the installation menu does not appear after a few seconds, go to **Start > Run** (on the Windows Start menu) and type `<drive>:\Application\Modular Instruments Measurement Manager\setup.exe`, where `drive` is your CD-ROM drive.
- 4 Click **OK** to begin installation.
- 5 If you do not have the Agilent T&M Toolkit 2.1 Runtime version, Microsoft .NET Framework version 1.1 and 2.0, and Agilent T&M Toolkit Redistributable Package 2.1 patch installed, the

InstallShield Wizard software pre-requisite will appear as shown in the following figure.

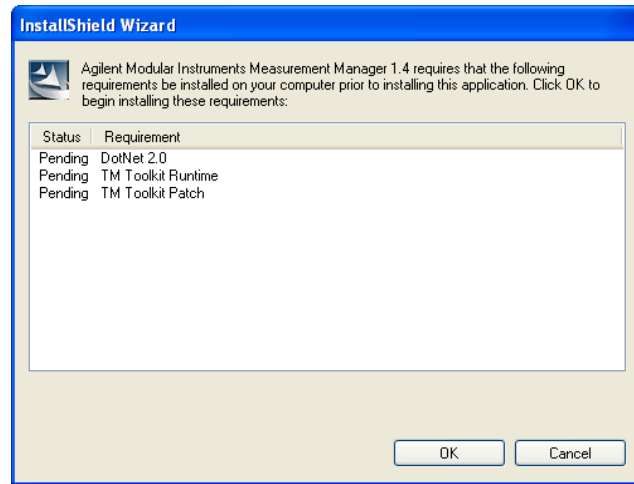

**6** Click **OK** to begin installation of the listed missing software.

#### NOTE

If you have Agilent VEE installed, you may need to install the Agilent T&M Toolkit 2.1 Runtime version manually.

- Click **Start > Run...**
- Type `<drive>:Utilities\Agilent T&M Toolkit Redistributable Package 2.1\setup.exe`, where `<drive>` is your CD drive letter.

**7** Once the above installation is completed, installation of the Agilent Measurement Manager software will proceed as normal.

**8** Follow the instructions on your screen to proceed with the Agilent Measurement Manager software installation.

**9** When the InstallShield Wizard appears, click **Next >** to begin the Agilent Measurement Manager installation.

**10** Read the License Agreement carefully. If you accept the terms, select the radio button that labeled **I accept the terms in the license agreement** and click **Next >** to continue.

- 11 Type in your user name in the User Name text box and organization name in the Organization text box. If there are more than one person using the same computer, select the radio button that labeled **Anyone who uses this computer**, otherwise select radio button labeled **Only for me**.
- 12 The default location to install the software is C:\Program Files\Agilent\Measurement Manager 1.4\. If you prefer to install the software to other location, click **Change...** to change the destination of the folder. When you are done, Click **Next >** to continue.
- 13 If you are ready to install the Agilent Measurement Manager, click **Install** to begin installation.
- 14 Click **Finish** when the installation has completed. A shortcut for this software will be created on your desktop.

**NOTE**

USING THE LICENSED MATERIALS INDICATES YOUR ACCEPTANCE OF THE LICENSE TERMS. IF YOU DO NOT AGREE TO ALL OF THESE TERMS, YOU MAY RETURN ANY UNOPENED LICENSED MATERIALS FOR A FULL REFUND. IF THE LICENSED MATERIALS ARE BUNDLED OR PRE-LOADED WITH ANOTHER PRODUCT, YOU MAY RETURN THE ENTIRE UNUSED PRODUCT FOR A FULL REFUND.

---

## E. Connect Your Device to the PC

- 1 After all installations have been successfully completed, connect the power cord to the AC/DC power adapter. The AC/DC power adapter requirements are 110 V/240 VAC, 50/60 Hz, with output voltage of +12 VDC.
- 2 Insert the DC output plug from the AC/DC power adapter to the power jack on the rear panel of the USB device.
- 3 Connect any of the U2600A series instrument to any USB ports on your PC with the USB cable.
- 4 If this is the first time you connect the instrument to your PC, the Found New Hardware Wizard window will appear as shown below. Select **Yes, this time only** and click **Next** to proceed.



- 5 Select **Install the software automatically (Recommended)** and click **Next**.
- 6 A warning message will appear in Hardware Installation window, as shown below. Click **Continue Anyway** to proceed with the installation of the driver.



### NOTE

If you do not wish to receive similar warning message in future, follow the instructions below.

- 1 Go to **Start > Control Panel** and double-click **System**.
- 2 Select **Hardware** tab and on the Drivers panel click **Driver Signing**. The Driver Signing Options dialog box will appear.
- 3 Select **Ignore** to disable the warning message.

7 Click **Finish** to complete the installation.

8 When installation has been completed, the Assign USB device alias window will appear. Each time a USB device is plugged in, this dialog box will appear. To configure or disable this dialog, select an option in the **Show this dialog** panel and click **OK**.

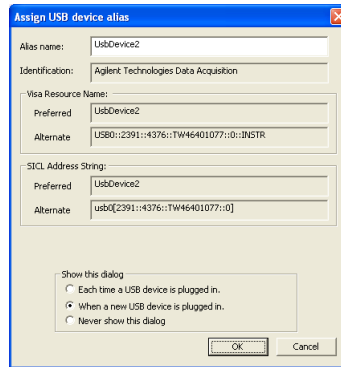

9 The USB device is now ready for usage.

### NOTE

Before proceeding, you may verify your connected device using Agilent Connection Expert.

## F. Launch Your Agilent Measurement Manager

### NOTE

- Agilent IO Control will launch automatically when you start your PC.
- Launching Agilent Measurement Manager without Agilent IO Control running will cause Agilent Measurement Manager to fail from detecting or establishing any connection with the USB device connected to your PC.
- To launch Agilent IO Control, go to **Start > All Programs > Agilent IO Libraries Suite > Agilent Connection Expert**.

- 1 Double-click the Agilent Measurement Manager software icon on your desktop or go to **Start > All Programs > Agilent > Modular Products > Measurement Manager** to launch the software.
- 2 The Select USB Device dialog box will appear. It will show all the DIO modules that are connected to your PC. To start the application, select a DIO module and click **OK** to establish the connection.

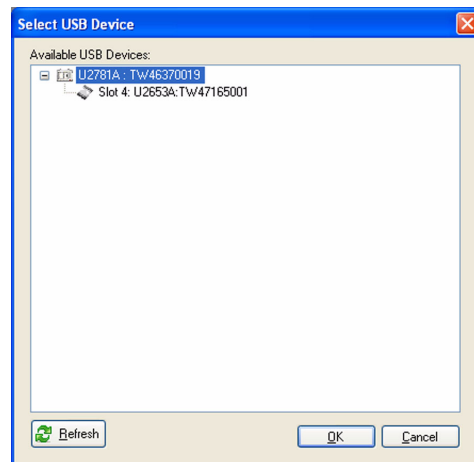

## L-Mount Kit Installation

The L-Mount kit is to be used with Agilent U2781A USB modular instrument chassis. The following instructions describe simple procedures of installing the L-Mount kit to a U2600A USB modules.

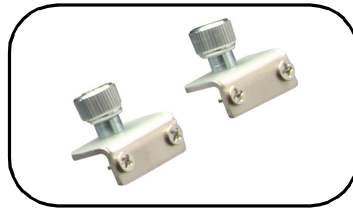

**1** Unpack the L-Mount kit from the packaging.

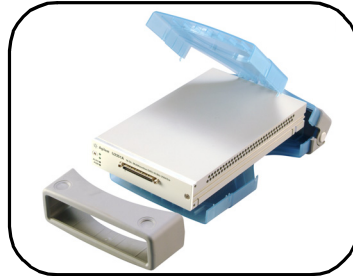

**2** Remove your USB device from its plastic casing by pulling the bumper (front end of the casing) outward direction. Then, lift the plastic body casing and remove it from your USB device.

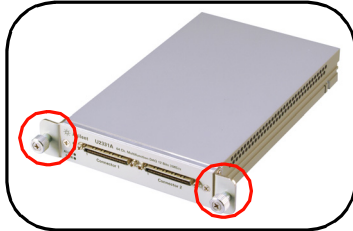

**3** Using the *Philip* screw driver, screw the L-Mount kit to your USB device.

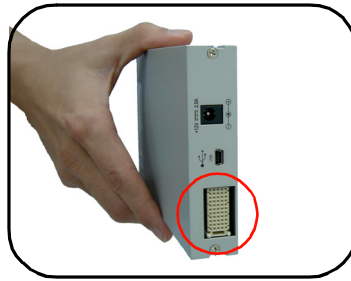

**4** To slot in the USB module to your chassis, turn your module perpendicularly and ensure that the 55-pin backplane connector is at the bottom side of the USB module.



**5** Your USB module is now ready to be plug into an instrument chassis.

## General Maintenance

**NOTE**

Repair or service which are not covered in this manual should only be performed by qualified personnel.

---

To remove the dirt or moisture the USB device, follow the instructions below.

- 1** Power off the USB device and remove the AC/DC adapter cord and USB cable from your device.
- 2** Remove your USB device from its plastic casing by pulling at the bumper (front end of the casing) outward direction. Then, lift the plastic body casing and remove it from your USB device.
- 3** Holding your USB device, shake out any dirt that may have accumulated on the panel of your USB device.
- 4** Wipe your USB device with a dry clean cloth.

## Additional Information

### Hardware verification

Agilent Connection Expert is one of the utilities of Agilent IO Libraries. It can automatically detect the USB devices that were connected to the PC and enables the communication between the USB device and the PC. To verify that your USB device has established a connection with your PC, do the following steps.

- 1 Go to **Start > All Programs > Agilent IO Libraries Suite > Agilent Connection Expert** to launch the Agilent Connection Expert.
- 2 The connected USB device will be visible in the **Instrument I/O on this PC** panel as indicated in the following. Select the DIO connection interface and right-click.

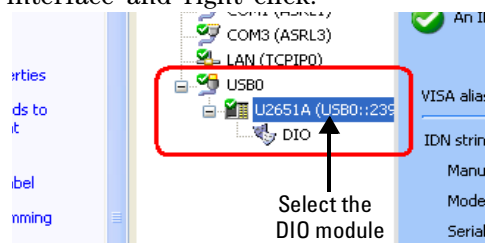

- 3 A context menu will appear. Click **Send Commands To This Instrument**. The Agilent Interactive IO dialog box will appear as shown below. Click **Send & Read** to send the \*IDN? default SCPI command. The instrument's response will be displayed in the **Instrument Session History** panel.

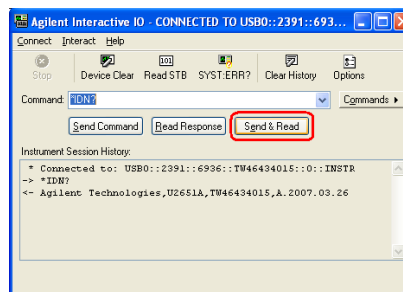

- 4 Successful communication between the PC and the connected hardware indicate successful hardware installation and connection establishment.

### Sample code

Sample codes for Agilent VEE, LabView and Microsoft (C#, C++, VB7 and VB6) are provided to help you get started and familiarized with the instrument. The sample codes provided for each language are as follows.

- **Example1:** Demonstrates the initialization of the instrument
- **ReadWriteChannel:** Read data from instrument and write data to instrument
- **Interrupt:** Demonstrates how the interrupt function works
- **Trigger:** Demonstrates how the trigger function works. An error will be shown if user tries to write the value after the trigger has been executed.
- **Custom channel:** User can group eight DI bits to form a new DI channel or group eight DO bits to form a new DO channel. The new DI or DO channels can then be used to perform normal DIO operation.

#### To view the sample code

Select **Sample Code** on the Agilent Modular Products Installation Menu and choose the type of language. See the following figure.

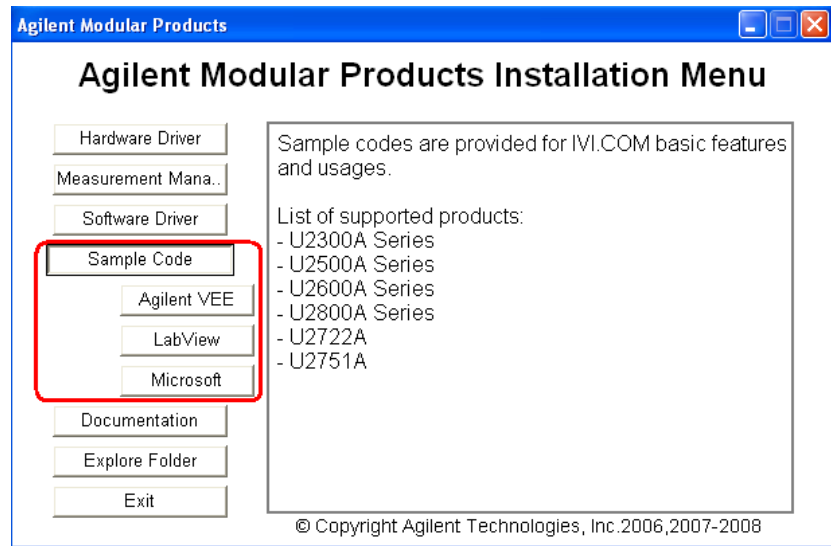

## **1 Getting Started**



## 2 Connector Pins Configuration

Introduction	28
Connector Pins Configuration for U2651A	29
Connector Pins Configuration for U2652A	31
Connector Pins Configuration for U2653A	33
55-pin Connector (J1) Pins Configuration	35

This chapter describes the U2600A series USB isolated DIO devices pins configuration and the theory operation of isolated DIO.



## Introduction

The U2600A series USB isolated digital I/O modules were equipped with 100-pin SCSI-II connector. The connector pins configuration for all of the U2600A series DIO modules are provided in this chapter. When the DIO module is used in a modular instrument chassis (U2781A), see [Figure 2-1](#) for the pins numbering. When the DIO module is used as a standalone unit, see [Figure 2-2](#).

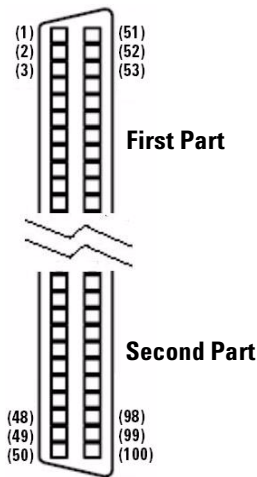

**Figure 2-1** Connector in vertical view

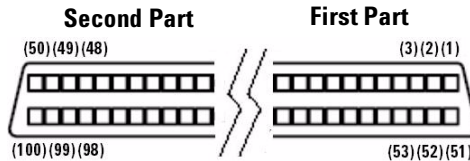

**Figure 2-2** Connector in horizontal view

## Connector Pins Configuration for U2651A

First Part			Second Part			
DI_101.0/301	<b>1</b>	<b>51</b>	DI_102.0	<b>26</b>	<b>76</b>	DO_202.0
DI_101.1/302	<b>2</b>	<b>52</b>	DI_102.1	<b>27</b>	<b>77</b>	DO_202.1
DI_101.2	<b>3</b>	<b>53</b>	DI_102.2	<b>28</b>	<b>78</b>	DO_202.2
DI_101.3	<b>4</b>	<b>54</b>	DI_102.3	<b>29</b>	<b>79</b>	DO_202.3
DI_101.4	<b>5</b>	<b>55</b>	DI_102.4	<b>30</b>	<b>80</b>	DO_202.4
DI_101.5	<b>6</b>	<b>56</b>	DI_102.5	<b>31</b>	<b>81</b>	DO_202.5
DI_101.6	<b>7</b>	<b>57</b>	DI_102.6	<b>32</b>	<b>82</b>	DO_202.6
DI_101.7	<b>8</b>	<b>58</b>	DI_102.7	<b>33</b>	<b>83</b>	DO_202.7
COM_101	<b>9</b>	<b>59</b>	COM_102	<b>34</b>	<b>84</b>	VDD_202
COM_101	<b>10</b>	<b>60</b>	COM_102	<b>35</b>	<b>85</b>	DO_GND
COM_101	<b>11</b>	<b>61</b>	COM_102	<b>36</b>	<b>86</b>	DO_GND
COM_101	<b>12</b>	<b>62</b>	COM_102	<b>37</b>	<b>87</b>	DO_GND
DI_103.0	<b>13</b>	<b>63</b>	DI_104.0	<b>38</b>	<b>88</b>	DO_204.0
DI_103.1	<b>14</b>	<b>64</b>	DI_104.1	<b>39</b>	<b>89</b>	DO_204.1
DI_103.2	<b>15</b>	<b>65</b>	DI_104.2	<b>40</b>	<b>90</b>	DO_204.2
DI_103.3	<b>16</b>	<b>66</b>	DI_104.3	<b>41</b>	<b>91</b>	DO_204.3
DI_103.4	<b>17</b>	<b>67</b>	DI_104.4	<b>42</b>	<b>92</b>	DO_204.4
DI_103.5	<b>18</b>	<b>68</b>	DI_104.5	<b>43</b>	<b>93</b>	DO_204.5
DI_103.6	<b>19</b>	<b>69</b>	DI_104.6	<b>44</b>	<b>94</b>	DO_204.6
DI_103.7	<b>20</b>	<b>70</b>	DI_104.7	<b>45</b>	<b>95</b>	DO_204.7
COM_103	<b>21</b>	<b>71</b>	COM_104	<b>46</b>	<b>96</b>	VDD_204
COM_103	<b>22</b>	<b>72</b>	COM_104	<b>47</b>	<b>97</b>	DO_GND
COM_103	<b>23</b>	<b>73</b>	COM_104	<b>48</b>	<b>98</b>	DO_GND
COM_103	<b>24</b>	<b>74</b>	COM_104	<b>49</b>	<b>99</b>	DO_GND
NC	<b>25</b>	<b>75</b>	NC	<b>50</b>	<b>100</b>	+5 V

Figure 2-3 Pins configuration for U2651A

**Table 2-1** Pins legend for U2651A

<b>Pin</b>	<b>Descriptions</b>
DI_10n.0...7	Isolated digital input channel “n” and bit 0 to 7; n = 1, 2, 3, 4
DO_20n.0...7	Isolated digital output channel “n” and bit 0 to 7; n = 1, 2, 3, 4
COM_101	Common junction for input channel 1
COM_102	Common junction for input channel 2
COM_103	Common junction for input channel 3
COM_104	Common junction for input channel 4
VDD_201	VDD pin for output channel 1
VDD_202	VDD pin for output channel 2
VDD_203	VDD pin for output channel 3
VDD_204	VDD pin for output channel 4
DO_GND	Ground return path of isolated channels
+5 V	On board +5 V regulated power supply
NC	No connection

## Connector Pins Configuration for U2652A

First Part			Second Part			
DI_101.0/301	<b>1</b>	<b>51</b>	DI_102.0	<b>26</b>	<b>76</b>	DI_106.0
DI_101.1/302	<b>2</b>	<b>52</b>	DI_102.1	<b>27</b>	<b>77</b>	DI_106.1
DI_101.2	<b>3</b>	<b>53</b>	DI_102.2	<b>28</b>	<b>78</b>	DI_106.2
DI_101.3	<b>4</b>	<b>54</b>	DI_102.3	<b>29</b>	<b>79</b>	DI_106.3
DI_101.4	<b>5</b>	<b>55</b>	DI_102.4	<b>30</b>	<b>80</b>	DI_106.4
DI_101.5	<b>6</b>	<b>56</b>	DI_102.5	<b>31</b>	<b>81</b>	DI_106.5
DI_101.6	<b>7</b>	<b>57</b>	DI_102.6	<b>32</b>	<b>82</b>	DI_106.6
DI_101.7	<b>8</b>	<b>58</b>	DI_102.7	<b>33</b>	<b>83</b>	DI_106.7
COM_101	<b>9</b>	<b>59</b>	COM_102	<b>34</b>	<b>84</b>	COM_106
COM_101	<b>10</b>	<b>60</b>	COM_102	<b>35</b>	<b>85</b>	COM_106
COM_101	<b>11</b>	<b>61</b>	COM_102	<b>36</b>	<b>86</b>	COM_106
COM_101	<b>12</b>	<b>62</b>	COM_102	<b>37</b>	<b>87</b>	COM_106
DI_103.0	<b>13</b>	<b>63</b>	DI_104.0	<b>38</b>	<b>88</b>	DI_108.0
DI_103.1	<b>14</b>	<b>64</b>	DI_104.1	<b>39</b>	<b>89</b>	DI_108.1
DI_103.2	<b>15</b>	<b>65</b>	DI_104.2	<b>40</b>	<b>90</b>	DI_108.2
DI_103.3	<b>16</b>	<b>66</b>	DI_104.3	<b>41</b>	<b>91</b>	DI_108.3
DI_103.4	<b>17</b>	<b>67</b>	DI_104.4	<b>42</b>	<b>92</b>	DI_108.4
DI_103.5	<b>18</b>	<b>68</b>	DI_104.5	<b>43</b>	<b>93</b>	DI_108.5
DI_103.6	<b>19</b>	<b>69</b>	DI_104.6	<b>44</b>	<b>94</b>	DI_108.6
DI_103.7	<b>20</b>	<b>70</b>	DI_104.7	<b>45</b>	<b>95</b>	DI_108.7
COM_103	<b>21</b>	<b>71</b>	COM_104	<b>46</b>	<b>96</b>	COM_108
COM_103	<b>22</b>	<b>72</b>	COM_104	<b>47</b>	<b>97</b>	COM_108
COM_103	<b>23</b>	<b>73</b>	COM_104	<b>48</b>	<b>98</b>	COM_108
COM_103	<b>24</b>	<b>74</b>	COM_104	<b>49</b>	<b>99</b>	COM_108
NC	<b>25</b>	<b>75</b>	NC	<b>50</b>	<b>100</b>	NC

Figure 2-4 Pins configuration for U2652A

**Table 2-2** Pins legend for U2652A

<b>Pin</b>	<b>Descriptions</b>
DI_10n.0...7	Isolated digital input channel "n" and bit 0 to 7; n = 1 to 8
COM_101	Common junction for input channel 1
COM_102	Common junction for input channel 2
COM_103	Common junction for input channel 3
COM_104	Common junction for input channel 4
COM_105	Common junction for input channel 5
COM_106	Common junction for input channel 6
COM_107	Common junction for input channel 7
COM_108	Common junction for input channel 8
NC	No connection

## Connector Pins Configuration for U2653A

First Part			Second Part				
DO_201.0	<b>1</b>	<b>51</b>	DO_202.0	<b>26</b>	<b>76</b>	DO_206.0	
DO_201.1	<b>2</b>	<b>52</b>	DO_202.1	<b>27</b>	<b>77</b>	DO_206.1	
DO_201.2	<b>3</b>	<b>53</b>	DO_202.2	<b>28</b>	<b>78</b>	DO_206.2	
DO_201.3	<b>4</b>	<b>54</b>	DO_202.3	<b>29</b>	<b>79</b>	DO_206.3	
DO_201.4	<b>5</b>	<b>55</b>	DO_202.4	<b>30</b>	<b>80</b>	DO_206.4	
DO_201.5	<b>6</b>	<b>56</b>	DO_202.5	<b>31</b>	<b>81</b>	DO_206.5	
DO_201.6	<b>7</b>	<b>57</b>	DO_202.6	<b>32</b>	<b>82</b>	DO_206.6	
DO_201.7	<b>8</b>	<b>58</b>	DO_202.7	<b>33</b>	<b>83</b>	DO_206.7	
VDD_201	<b>9</b>	<b>59</b>	VDD_202	<b>34</b>	<b>84</b>	VDD_206	
DO_GND	<b>10</b>	<b>60</b>	COM_102	<b>35</b>	<b>85</b>	COM_106	
DO_GND	<b>11</b>	<b>61</b>	COM_102	<b>36</b>	<b>86</b>	COM_106	
DO_GND	<b>12</b>	<b>62</b>	COM_102	<b>37</b>	<b>87</b>	COM_106	
DO_203.0	<b>13</b>	<b>63</b>	DO_204.0	<b>38</b>	<b>88</b>	DO_208.0	
DO_203.1	<b>14</b>	<b>64</b>	DO_204.1	<b>39</b>	<b>89</b>	DO_208.1	
DO_203.2	<b>15</b>	<b>65</b>	DO_204.2	<b>40</b>	<b>90</b>	DO_208.2	
DO_203.3	<b>16</b>	<b>66</b>	DO_204.3	<b>41</b>	<b>91</b>	DO_208.3	
DO_203.4	<b>17</b>	<b>67</b>	DO_204.4	<b>42</b>	<b>92</b>	DO_208.4	
DO_203.5	<b>18</b>	<b>68</b>	DO_204.5	<b>43</b>	<b>93</b>	DO_208.5	
DO_203.6	<b>19</b>	<b>69</b>	DO_204.6	<b>44</b>	<b>94</b>	DO_208.6	
DO_203.7	<b>20</b>	<b>70</b>	DO_204.7	<b>45</b>	<b>95</b>	DO_208.7	
VDD_203	<b>21</b>	<b>71</b>	VDD_204	<b>46</b>	<b>96</b>	VDD_208	
DO_GND	<b>22</b>	<b>72</b>	DO_GND	<b>47</b>	<b>97</b>	DO_GND	
DO_GND	<b>23</b>	<b>73</b>	DO_GND	<b>48</b>	<b>98</b>	DO_GND	
DO_GND	<b>24</b>	<b>74</b>	DO_GND	<b>49</b>	<b>99</b>	DO_GND	
NC	<b>25</b>	<b>75</b>	NC	+5 V	<b>50</b>	<b>100</b>	+5 V

Figure 2-5 Pins configuration for U2653A

**Table 2-3** Pins legend for U2653A

<b>Pin</b>	<b>Descriptions</b>
DO_20n.0..7	Isolated digital output channel “n” and bit 0 to 7; n = 1 to 8
VDD_201	VDD pin for output channel 1
VDD_202	VDD pin for output channel 2
VDD_203	VDD pin for output channel 3
VDD_204	VDD pin for output channel 4
VDD_205	VDD pin for output channel 5
VDD_206	VDD pin for output channel 6
VDD_207	VDD pin for output channel 7
VDD_208	VDD pin for output channel 8
DO_GND	Ground return path of isolated channels
+5 V	On board +5 V regulated power supply
NC	No connection

## 55-pin Connector (J1) Pins Configuration

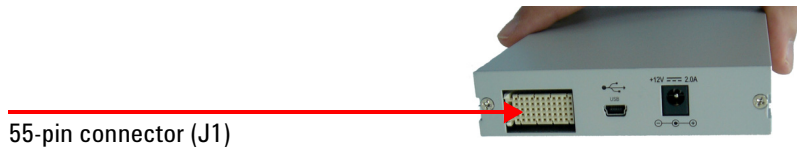

55-pin connector (J1)

**Figure 2-6** Connector (J1) 55-pin

**Table 2-4** U2600A series J1 connector pin assignment

11	GND	+12 V	+12 V	GND	USB_D+	USB_D-	GND
10	GND	+12 V	+12 V	+12 V	GND	GND	GND
9	GND	+12 V	+12 V	+12 V	GND	USB_VBUS	GND
8	GND	NC	BRSV	GND	NC	NC	GND
7	GND	NC	GA0	NC	GND	NC	GND
6	GND	NC	GA1	GND	NC	NC	GND
5	GND	NC	GA2	NC	GND	NC	GND
4	GND	NC	STAR_TRIG	GND	NC	NC	GND
3	GND	NC	GND	NC	GND	NC	GND
2	GND	NC	NC	GND	NC	NC	GND
1	GND	NC	GND	NC	GND	NC	GND
	Z	A	B	C	D	E	F

**Table 2-5** U2600A series J1 connector legend

Pin	Descriptions
+12 V	+12 V power from backplane
GND	Ground
BRSV	Reserved pin
STAR_TRIG	Star trigger
USB_VBUS	USB based power, +5 V
USB_D+, USB_D-	USB differential pair

## 2 Connector Pins Configuration



## 3 Features and Functions

Digital Input/Output	38
Isolated digital input channels	39
Isolated digital output channels	40
Virtual Port Group Function	43
Interrupt Function	44
Trigger Function	48

This chapter describes the features and functions of the Agilent U2600A series DIO modules. This includes the operations of the isolated digital input/output, group function, interrupt function and trigger function.



## Digital Input/Output

The U2600A series digital IO modules provides up to 64-bit of high density opto-isolated digital input and output for USB 2.0 interface-based industrial applications.

The 32-bit U2651A DIO model is segmented into eight channels with four channels as digital input channels (CH101 to CH104) and four channels as digital output channels (CH201 to CH204). Each channel consists of eight data bit. Refer to [“Connector Pins Configuration for U2651A”](#) on page 27 for more information on the pins configuration.

The 64-bit U2652A digital input model is segmented into eight channels where all channels are digital input channels (CH101 to CH108). Each channel consists of eight data bit. Refer to [“Connector Pins Configuration for U2652A”](#) on page 29 for more information on the pins configuration.

The 64-bit U2653A digital output model is segmented into eight channels where all channels are digital output channels (CH201 to CH208). Each channel consists of eight data bit. Refer to [“Connector Pins Configuration for U2653A”](#) on page 31 for more information on the pins configuration.

## Isolated digital input channels

The U2600A series DIO modules are equipped with up to 64-bit of opto-isolated digital input, which provides electrical isolation protection to the inner DIO circuitry. The circuit diagram of an isolated input bit is shown in [Figure 3-1](#). The maximum and minimum allowable input voltage at  $DI_{in}$  and  $DI_{COM}$  are 24 V and -24 V, respectively; regardless of its polarity as shown below:

- 1 24 V at  $DI_{in}$  and -24 V at  $DI_{COM}$  or
- 2 24 V at  $DI_{COM}$  and -24 V at  $DI_{in}$ .

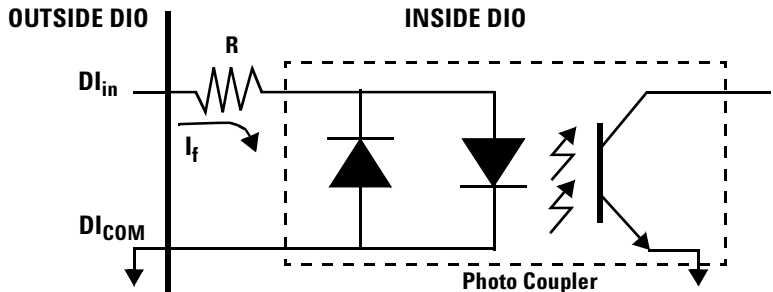

**Figure3-1** Isolated digital input bit through a photo coupler

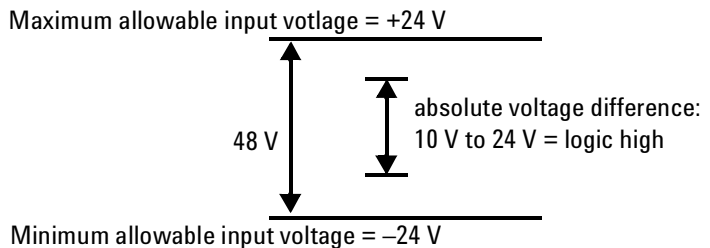

**Figure3-2** The maximum and minimum allowable input voltage at  $DI_{in}$  and  $DI_{COM}$  and the absolute voltage range for DIO to see a logic high

For the DIO module to read the digital input as logic high, the absolute input voltage range (regardless of its polarity) across the  $DI_{in}$  and  $DI_{COM}$  should be in the range from 10 V to 24 V (see [Figure 3-2](#)). For example, the voltage at  $DI_{in}$  should be greater than  $DI_{COM}$  by at least 10 V (up to 24 V) or the voltage at  $DI_{COM}$  should be greater than  $DI_{in}$  by at least 10 V (up to 24 V). As long as there is an absolute potential difference of more than 10 V (up to 24 V) across  $DI_{in}$  and  $DI_{COM}$ , the DIO module will see a logic high at that bit.

#### CAUTION

Do not supply excessive voltage to the digital input bits as it will cause excessive heating on the resistor and damage the instrument. The maximum absolute voltage difference is 24 V.

---

## Isolated digital output channels

The common ground connection of isolated digital output is shown in the [Figure 3-3](#). When the isolated digital output is switched **ON**, the current will conduct on the power MOSFET (see [Figure 3-1](#)) and the current will flow as indicated by the arrow. When the isolated digital output is switched **OFF**, the current will not conduct through the load (see [Figure 3-4](#)).

#### CAUTION

When the load is of an inductance nature such as relay, coil or motor, the VDD pin should be connected to an external power source.

---

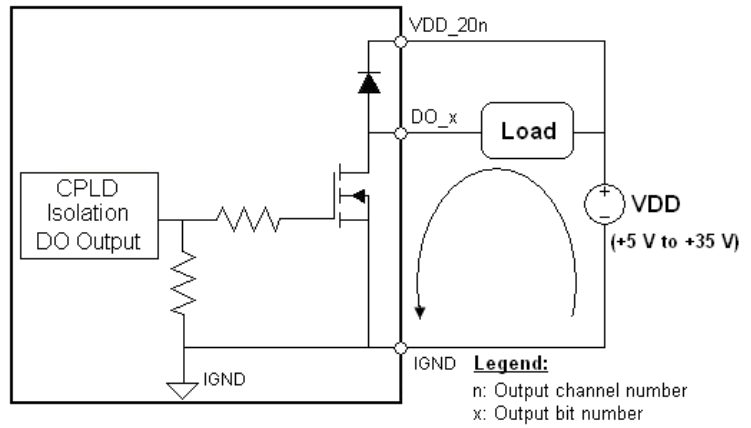

**Figure3-3** Isolated digital output is switched on with load

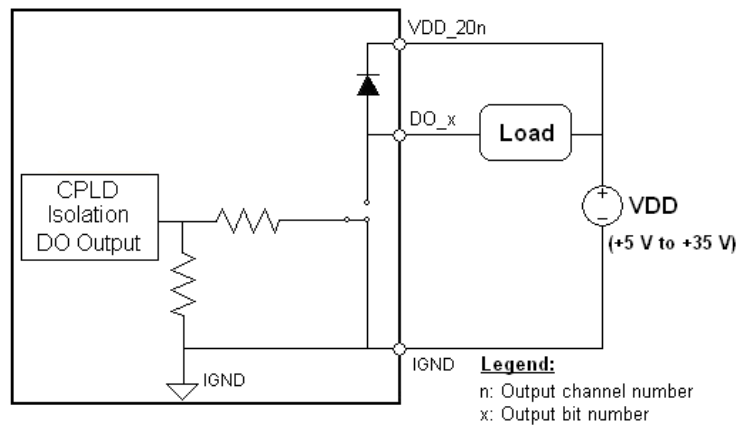

**Figure3-4** Isolated digital output is switched off with load

A fly-wheel diode is provided at the drain of the MOSFET. It is used in closed loop current release and to protect the MOSFET from any high reversed voltage, which may be generated by the inductive load when the output stage is being switched from **ON** to **OFF**.

The following SCPI examples show the way to read a digital input channel and to output a digital output signal.

#### **SCPI Example 1, Read one bit of a digital input channel**

```
-> DIG:DATA:BIT? 1, (@101) //Read bit 1 of channel 101
<- 1 //The return value will be either 1 or 0.
// 1 means there is a input at that
// particular bit.
```

#### **SCPI Example 2, Read a digital input channel**

```
-> DIG:DATA:BYTE? (@101) //Read digital input at channel 101
<- 9 //The return value is in decimal, where
// 9 means bit 0 and bit 3 of channel 101
// have digital inputs.
```

#### **SCPI Example 3, Output a signal at one bit of a digital output channel**

```
-> SOUR:DIG:DATA:BIT 1, 6, (@201) //Set to "1" for bit 6 of
// channel 201.
-> SOUR:DIG:DATA:BIT? 6, (@201) //Query the output
// signal at bit 6 of channel
// 201.
<- 1 //Return of "1" means
// there is an output signal.
```

#### **SCPI Example 4, Output a signal at a digital output channel**

```
-> SOUR:DIG:DATA:BYTE 123, (@201:204) //Output 123 (in
// decimal) at channel
// 201 to 204.
-> SOUR:DIG:DATA:BYTE? (@201:204) //Query the output
// signal at channel 201
// to 204.
<- 123, 123, 123, 123
```

## Virtual Port Group Function

The U2600A series DIO modules allows you to randomly select any eight input bits or output bits and group them into one channel as a virtual DIO port. You must select exactly eight bits to group them to a virtual channel. However, only input bits can be grouped with input bits and output bits with output bits. Therefore, the input bits should not be grouped with the output bits.

### NOTE

You must select exactly eight input bits and group them into virtual channel 199 or exactly eight output bits and group them into channel 299.

For input operations, the channel number is 199 and for output operations, the channel number is 299. The grouping does not need to be sequential in nature, since the bits in channel 199 or 299 will link the specified bits to its reference points.

The following shows the examples of SCPI commands on how to group the input bits in channel number 199 and output bits in channel number 299.

### SCPI Example 1, Grouping the input bits

```
//Group the eight input bits in channel number 199
-> CONF:DIG:GRO 101.0,101.3,102.5,102.2,102.5,102.7,101.2,102.6, (@199)
-> DIG:DATA? (@199) //Query the values at the channel
```

### SCPI Example 2, Grouping the output bits

```
//Group the eight output bits in channel number 299
-> CONF:DIG:GRO 202.0,202.3,202.5,202.7,203.5,203.7,204.0,204.5, (@299)
-> SOUR:DIG:DATA 0, (@299) //Set channel number 299 to output all zeros

//Group different output bits in channel number 299
-> CONF:DIG:GRO 202.0,202.1,202.5,202.7,203.5,203.7,204.0,204.5, (@299)
-> SOUR:DIG:DATA 1, (@299) //Set channel number 299 to output with ones
```

## Interrupt Function

This feature is available for the U2651A and U2652A. There are two interrupt sources for the interrupt function, which are bit 301 and bit 302 located at input channel 101. They are actually physically sharing the same bit with bit 101.0 and bit 101.1. See “[Connector Pins Configuration for U2651A](#)” on page 29 and “[Connector Pins Configuration for U2652A](#)” on page 31 for the location of bit 301 and bit 302.

To use this feature, the user has to enable the interrupt first by selecting the triggering source (i.e. bit 301 or bit 302). For example, the following SCPI command is used to set bit 301 as the triggering source.

```
SENS: DIG: INT: ENAB ON, (@301)
```

When the logic level of bit 301 changes from “0” to “1” (i.e. an interrupt has occurred), the bit 0 of *Event Register* (EV) is set to “1”. See [Figure 3-5](#). To alert the *Status Byte Register* that an interrupt has occurred, the user has to enable the *Enable Register* (EN) at the *Interrupt Operation Register* using the following SCPI command:

```
STAT: INT: ENAB 1
```

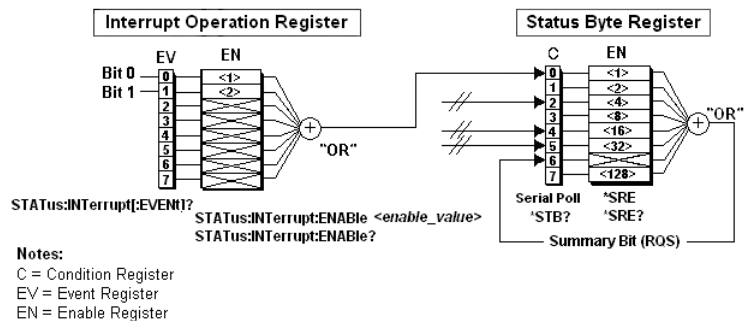

**Figure3-5** Enabling the Interrupt Operation Register will allow it to send a signal, “1” to the Status Byte Register when either the logic level for bit 301 or bit 302 changes from “0” to “1”.

The *Enable Register* acts like a gate for the *Interrupt Operation Register*. If the *Event Register* is not enabled (i.e. gate is close), the interrupt signal will not be sent to the *Status Byte Register*. If the *Event Register* is enabled, the interrupt signal will be sent to bit 0 of the *Status Byte Register*. To check whether the *Enable Register* is enabled, use the following SCPI command:

```
STAT:INT:ENAB?
```

If the return value is “1” (in binary is 01), it means that the information at bit 0 of *Event Register* in *Interrupt Operation Register* will be sent to bit 0 of *Status Byte Register*. If the return value is “2” (in binary is 10), it means that the information at bit 0 of *Event Register* in *Interrupt Operation Register* will be sent to bit 0 of *Status Byte Register*. To enable both bit 0 and bit 1 of *Enable Register* to send the information in bit 0 and bit 1 of *Event Register* in *Interrupt Operation Register*, send the following SCPI command:

```
STAT:INT:ENAB 3
```

The user may send the SCPI command “\*STB?” to query the status of the *Status Byte Register* and observe bit 0 of the return value to check whether an interrupt has occurred provided that the user has previously select the trigger source and enable the *Enable Register* of the *Interrupt Operation Register*.

The flowchart in [Figure 3-6](#) shows an example of the interrupt function operation.

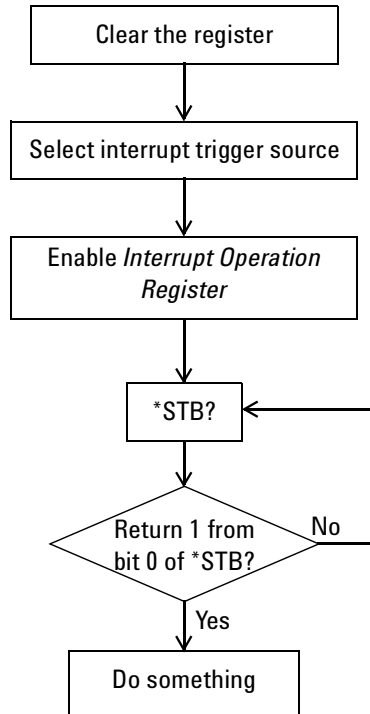

**Figure3-6** Flowchart for interrupt function operation

Firstly, it is recommended to clear the register prior to enabling the interrupt function. Use the SCPI command “\*CLS” to clear the register.

Secondly, choose the trigger source (for example bit 301) using the SCPI command “SENS:DIG:INT:ENAB ON, (@301)”.

Then, enable the *Interrupt Operation Register* so that it will alert the *Status Byte Register* whenever an interrupt has occurred.

Finally, check the status in *Status Byte Register* with the SCPI command “\*STB?”. If bit 0 of STB returns “1”, it means that an interrupt has occurred. If bit 0 of STB

returns “0”, continue to check its status. The user may do something when an interrupt has occurred, for example output a signal from the DIO device.

### SCPI Example 1, Enable interrupt at bit 301 and

```

-> *RST;*CLS //Clears the register to start from known state
-> SENS:DIG:INT:ENAB ON, (@301) //Enable interrupt for bit 0
-> ... //Interrupt occurs in bit 301
-> *STB? //Query Status Byte Register
<- +0 //Interrupt occurred but STB doesn't see it yet
-> STAT:INT:ENAB 1 //Enable the bit so STB can see it
-> *STB? //Query STB again
<- +1 //Now STB sees that an interrupt has occurred
-> STAT:INT:EVENT? //Find out which interrupt source
<- +1 //“1” means the interrupt source is from bit 301
-> STAT:INT:EVENT? //Once read the event is cleared
<- +0 //0 now. If there is another interrupt, it will be set
to 1 again

```

#### NOTE

Refer to *U2600A Series USB Isolated Digital Input/Output Programmer's Reference* under the topic “[SENSE:]DIGital:INTerrupt[:ENABle]” for more example on interrupt function.

## Trigger Function

The major difference between interrupt function and trigger function is that after the user selects any trigger source, the IO operation will be frozen. In other words, the output will stay at the previous stage and the input reading values will also be frozen. Whereas for the interrupt function, the IO operation is still running.

The following flowchart illustrates the way the trigger function operates.

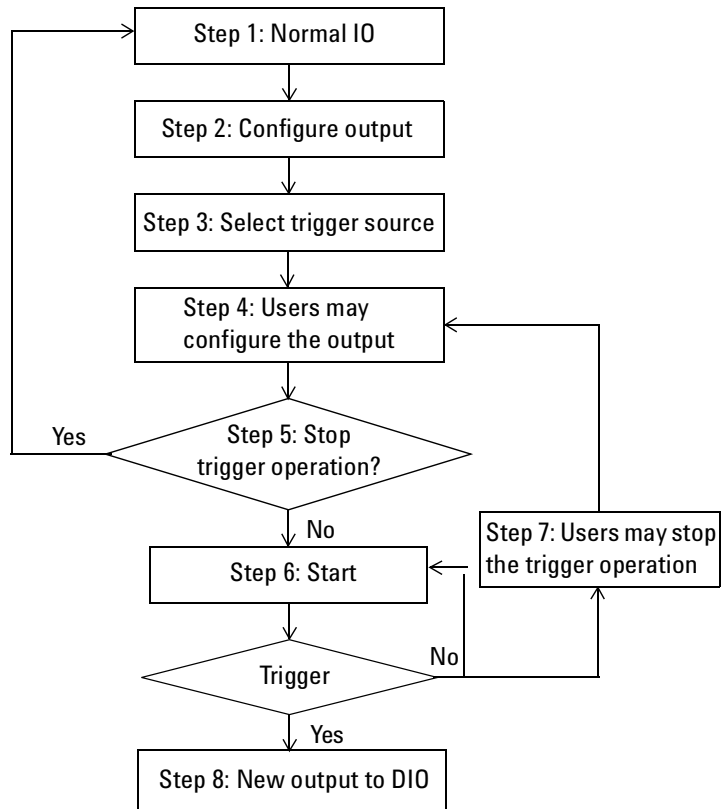

**Figure3-7** Flowchart for trigger function operation

**Table 3-1** Step-by-step descriptions for trigger function flowchart

Steps	Descriptions
Step 1	By default, no trigger source is selected (TRIG:SOUR NONE). Hence, all digital inputs and digital outputs will operate immediately.
Step 2	<p>Users may configure the desired output values before a trigger occurred. For example:</p> <pre>-&gt; SOUR: DIG: DATA: BYTE 123, (@201:204)</pre> <p>And read the input values, for example:</p> <pre>-&gt; SENS: DIG: DATA: BYTE? (@101:104) &lt;- 111, 111, 111, 111</pre>
Step 3	Select one of the trigger source. (TRIG:SOUR 301   302   STRG) The star trigger "STRG" trigger source can only be used when the DIO module is installed in a modular instrument U2700A chassis.
Step 4	<p>All IO operation will freeze when the user select one of the trigger source. So, if the user supply 98 to the input, sending the query command "SENS: DIG: DATA: BYTE? (@101:104)" will return "111, 111, 111, 111" even the supply value at the DIO module has changed to 98 (for this case).</p> <p>At this stage, users are allow to configure the output values. For example:</p> <pre>-&gt; SOUR: DIG: DATA: BYTE 220, (@201:204) -&gt; SOUR: DIG: DATA: BYTE? (@201:204) &lt;- 220, 220, 220, 220</pre> <p>Even though the query command returns "220, 220, 220, 220", the real output value at the hardware DIO module will remain the same as previous stage (Step 2), which is 123 in this case. The output value will remain at 123 until the DIO module receives the trigger signal.</p>
Step 5	Users may stop trigger operation at this stage by sending the command "TRIG:SOUR NONE". If this command is sent without receiving any trigger signal, then the query of this command "SOUR: DIG: DATA: BYTE? (@201:204)" should give back the previous stage (Step 2) value, which is 123 in this example but not 220.

---

**Step 6** Send the command "TRIG:MON ON" to start monitoring the trigger signal. Users are **NOT** allowed to change the output setting at this stage.

---

**Step 7** Users can stop monitoring the trigger signal manually at any time. To stop monitoring, send the command "TRIG:MON OFF".

---

**Step 8** If trigger happen, DIO module will output 220 (as configured in Step 4). The device will return to normal IO operation. So, when read the input value, it will return 98 (in this case).

The command "TRIG:MON:STAT?" is used to query the current monitoring status process. For example, when this command is sent at this stage:

```
-> TRIG:MON:STAT?  
<- +1  
-> TRIG:MON:STAT?  
<- +0
```

The "+1" indicates that trigger has happened. But this will only be shown once. If the query command is sent for the second time, it will reset to "+0".

The monitoring process will stop after trigger signal is received.

```
-> TRIG:MON?  
<- 0
```

---

#### Example 1, Trigger did not happen

```
-> *RST; *CLS  
-> SOUR: DIG: DATA: BYTE 123, (@201, 203)  
-> SOUR: DIG: DATA: BYTE 99, (@202, 204)  
-> SOUR: DIG: DATA: BYTE? (@201:204)  
  
<- 123, 99, 123, 99 // Actual hardware value at 123,99,123,99  
  
-> TRIG: SOUR 301 // Setting trigger source will not affects the  
-> SOUR: DIG: DATA: BYTE? (@201:204) output value. Thus, output values remained  
<- 123, 99, 123, 99  
  
-> SOUR: DIG: DATA: BYTE 44, (@201, 202) // Configure output value only. The actual  
-> SOUR: DIG: DATA: BYTE 222, (@203, 204) hardware output did not change yet, still remain  
at 123,99,123,99
```

```

-> SOUR: DIG: DATA: BYTE? (@201:204) // Actual hardware value is 123,99,123,99 but
<- 44, 44, 222, 222 // SCPI show 44,44,222,222. The SCPI value will be
source out, if the DAQ receives the trigger signal

-> TRIG: SOUR NONE // User decides not to use trigger function
anymore. Trigger does not happen

-> SOUR: DIG: DATA: BYTE? (@201:204) // Since trigger did not happen, the output value
<- 123, 99, 123, 99 // did not change. Thus SCPI return 123,99,123,99
to show the actual hardware status

```

### Example 2, Trigger happen

```

-> *CLS; *RST
-> SOUR: DIG: DATA: BYTE 11, (@204)
-> SOUR: DIG: DATA: BYTE 233, (@201)
-> SOUR: DIG: DATA: BYTE 9, (@202)
-> SOUR: DIG: DATA: BYTE 205, (@203)
-> SOUR: DIG: DATA: BYTE? (@201:204)
-> 233, 9, 205, 11 // Actual hardware value at 233,9,205,11

-> TRIG: SOUR 302 // Set trigger source at 302

-> SOUR: DIG: DATA: BYTE? (@201:204) // SCPI value remain
<- 233, 9, 205, 11

-> SOUR: DIG: DATA: LWOR 40154879, (@201) // User may configure the output value as many
-> SOUR: DIG: DATA: WORD? (@201, 203) // times as they like using different type "SOUR"
<- 46847, 612 // command. But the actual hardware value will not
-> SOUR: DIG: DATA: BYTE? (@201:204) // change until a trigger signal is received
-> 255, 182, 100, 2

-> SOUR: DIG: DATA: BYTE 33, (@202) // The last configured SOUR value will determine
-> SOUR: DIG: DATA: BYTE 145, (@201) // the later hardware value when a trigger signal is
-> SOUR: DIG: DATA: WORD 6523, (@203) // received
-> SOUR: DIG: DATA: BYTE? (@201:204)
-> 145, 33, 123, 25

-> TRIG: MON ON // Start monitor the trigger signal

// After start monitor trigger signal, users are not allow to change SOUR command
-> SOUR: DIG: DATA: BYTE 23, (@201)
-> SYST: ERR?
<- +308, "Channel not able to perform requested operation; Chan 201"

```

### 3 Features and Functions

```
-> SOUR: DIG: DATA: BYTE? (@201:204) // However, user is still allow to make query on
<- 145,33,123,25                      SOUR command. Note that the actual hardware
                                        is still at 233,9,205,11 but SCPI value is at
                                        145,33,123,25
```

#### \*\*\* Trigger happen \*\*\*

```
-> TRIG: MON: STAT? // Check whether trigger had happened and
<- +1              reset to zero when user query for second time
-> TRIG: MON: STAT?
<- +0

-> TRIG: MON? // This command will also be reset to OFF,
<- 0         indicating that the trigger monitoring process has
            been stopped

-> SOUR: DIG: DATA: BYTE? (@201:204) // Now the SCPI and actual hardware value are
<- 145,33,123,25                    the same, which is 145,33,123,25
```

#### \*\*\* From here onwards, user may choose to continue with trigger or turn off trigger \*\*\*

```
-> TRIG: SOUR NONE // Turn off trigger function

-> SOUR: DIG: DATA: BYTE? (@201:204) // Now the SOUR query command shows the
<- 145,33,123,25                    actual hardware value, which is 145,33,123,25
```

### Example 3, Interrupt commands during trigger are not allow

#### E.g. 1: After trigger source is selected, interrupt function feature is not allowed

```
-> *CLS; *RST

-> TRIG: SOUR 302 // Set 302 as trigger source

// Interrupt command is not allow in trigger mode. If used, an error will occur.
-> DIG: INT 1, (@301)
-> SYST: ERR?
<- +308, "Channel not able to perform requested operation; Chan 301"
-> DIG: INT 1, (@302)
-> SYST: ERR?
<- +308, "Channel not able to perform requested operation; Chan 302"

-> DIG: INT? (@301:302) // However, user can check whether the interrupt is enabled
<- 0,0
```

**E.g 2: Interrupt feature is disabled if a trigger source is selected**

```

-> *CLS; *RST

-> DIG:INT 1, (@302) // Interrupt command is not allow in trigger mode. If used, an error
-> DIG:INT? (@301:302) will occur.
<- 0,1

-> TRIG:SOUR 301 // Select 301 as trigger source
-> DIG:INT? (@301) // Interrupt feature will be automatically disabled when user select
<- 0 trigger source. "0" means the interrupt function is not enabled.
-> DIG:INT? (@302)
<- 0
-> DIG:INT? (@301:302)
<- 0,0

-> TRIG:SOUR NONE // Turn off the trigger source
-> DIG:INT? (@301:302) // This query command will still return 0,0
<- 0,0

```

**E.g. 3: STRG as the trigger source when used in the instrument modular chassis (U2781A)**

```

-> *CLS; *RST

-> TRIG:SOUR STRG // Select STRG as trigger source

-> STAT:INT:ENAB 3 // No error generated when enable the "STRG" trigger source. This
-> STAT:INT ENAB? command can still be use because it is only an enable register. Since
<- +3 interrupt comand has been disabled, this command have no effect on
-> STAT:INT? interrupt or trigger.
<- +0

```

#### Example 4, Group command during trigger

```
-> *CLS; *RST
-> CONF:DIG:GRO 101.3,104.2,101.7,102.5,103.6,102.0,103.4,102.1, (@199)
-> CONF:DIG:GRO 203.2,201.4,204.3,202.7,201.5,204.1,203.0,201.2, (@299)
-> SOUR:DIG:DATA:BYTE 234, (@299)
-> SOUR:DIG:DATA:BYTE? (@299)
<- 234

-> SOUR:DIG:DATA:BYTE? (@201:204) // Actual hardware value at 20,128,1,2
<- 20,128,1,2

-> TRIG:SOUR 302 // Set 302 as trigger source

-> SOUR:DIG:DATA:BYTE? (@201:204)
<- 20,128,1,2
-> SOUR:DIG:DATA:BYTE? (@299)
<- 234

-> SOUR:DIG:DATA:BYTE 31, (@299)
-> SOUR:DIG:DATA:BYTE? (@299)
<- 31

-> SOUR:DIG:DATA:BYTE? (@201:204)
<- 48,128,4,8

-> TRIG:MON ON

-> SOUR:DIG:DATA:BYTE 23, (@299)
-> SYST:ERR?
<- +308, "Channel not able to perform requested operation; Chan 299"

// However, users are still allow to re-arrange the channels in 299 or 199 since it will not alter the SCPI value,
// 48,128,4,8
-> CONF:DIG:GRO 201.2,202.4,203.3,204.7,201.5,202.1,203.0,204.2, (@299)
-> CONF:DIG:GRO 101.3,102.2,103.7,104.5,101.6,102.0,103.4,104.1, (@199)

-> SOUR:DIG:DATA:BYTE? (@299) // Although this value has changed from 31 to 16
<- 16 // due to re-configured of the channels, it will not
-> SOUR:DIG:DATA:BYTE? (@201:204) // affect the SCPI value. The value in channel
<- 48,128,4,8 // 201:204 still remain unchanged. Note that before
// the trigger occur, the hardware value still at
// 20,128,1,2 but SCPI value is at 48,128,4,8
```

\*\*\* TRIGGER OCCURED \*\*\*

```

-> TRIG:MON:STAT? // Check whether a trigger signal is detected
<- +1 // "1" mean trigger signal is detected
-> TRIG:MON:STAT? // Query the second will receive "0" because
<- +0 this command auto-reset the register to "0"
-> TRIG:MON? // Trigger monitoring process will be auto turned
<- 0 off when a trigger source is detected

-> SOUR:DIG:DATA:BYTE? (@201:204) // After the trigger signal is detect, the SCPI and
<- 48,128,4,8 actual hardware value are the same, which is
-> SOUR:DIG:DATA:BYTE? (@299) 48,128,4,8
<- 16

```

**\*\*\* From here onwards, users may choose to continue with trigger or turn off trigger function \*\*\***

```

-> TRIG:SOUR NONE // Turn off trigger function

```

### **3 Features and Functions**



## 4 Product Characteristics and Specifications

Product Characteristics [58](#)

Product Specifications [59](#)

U2600A series DIO specifications [59](#)

This chapter provides the information on general product characteristics and product specifications.



# Product Characteristics

<b>REMOTE INTERFACE</b>	<ul style="list-style-type: none"><li>• USB 2.0 High Speed</li><li>• USBTMC Class Device</li></ul>
<b>POWER REQUIREMENT</b>	<ul style="list-style-type: none"><li>• +12 VDC (Typical)</li><li>• 2 A (maximum) input rated current</li><li>• Installation Category II</li></ul>
<b>POWER CONSUMPTION</b>	+12 VDC, 260 mA (maximum)
<b>OPERATING ENVIRONMENT</b>	<ul style="list-style-type: none"><li>• Operating temperature from 0 °C to +55 °C</li><li>• Relative humidity at 15% to 85% RH (non-condensing)</li><li>• Altitude up to 2000 meters</li><li>• Pollution Degree 2</li><li>• For indoor use only</li></ul>
<b>STORAGE COMPLIANCE</b>	-20 °C to +70 °C
<b>SAFETY COMPLIANCE</b>	Certified with: <ul style="list-style-type: none"><li>• IEC 61010-1:2001/EN 61010-1:2001</li><li>• Canada: CAN/CSA-C22.2 No.61010-1-04</li><li>• USA: ANSI/UL 61010-1: 2004</li></ul>
<b>EMC COMPLIANCE</b>	<ul style="list-style-type: none"><li>• IEC 61326-1:2002/EN 61326-1:1997+A1:1998+A2:2001+A3:2003</li><li>• CISPR 11: 1990/EN55011:1990 – Group 1 Class A</li><li>• Canada: ICES-001: 2004</li><li>• Australia/New Zealand: AS/NZS CISPR11:2004</li></ul>
<b>SHOCK &amp; VIBRATION</b>	Tested to IEC/EN 60068-2
<b>IO CONNECTOR</b>	100-pin SCSI-II connector
<b>DIMENSION (WxDxH)</b>	Module dimension: <ul style="list-style-type: none"><li>• 120.00 mm x 182.40 mm x 44.00 mm (with plastic casing)</li><li>• 105.00 mm x 174.54 mm x 25.00 mm (without plastic casing)</li></ul> Terminal block dimension: <ul style="list-style-type: none"><li>• 158.00 mm x 118.60 mm x 51.50 mm</li></ul>
<b>WEIGHT</b>	<ul style="list-style-type: none"><li>• 535 g (with plastic casing)</li><li>• 370 g (without plastic casing)</li></ul>
<b>WARRANTY</b>	3 years

## Product Specifications

### U2600A series DIO specifications

**Table 4-1** Digital input product specifications for U2600A series DIO (U2651A, U2652A, and U2653A)

Digital Input			
Model Number	U2651A	U2652A	U2653A
Number of isolated bits	32-bit	64-bit	N/A
Input type	Opto-isolated	Opto-isolated	N/A
Maximum input voltage range <sup>1</sup>	24 V, non-polarity	24 V, non-polarity	N/A
Digital logic levels <sup>2</sup>	High: 10 V to 24 V Low: 0 V to 2.0 V	High: 10 V to 24 V Low: 0 V to 2.0 V	N/A
Input resistance	24 k $\Omega$ at 0.75 W	24 k $\Omega$ at 0.75 W	N/A
Input current (maximum)	1.5 mA per bit	1.5 mA per bit	N/A
Isolation voltage	1250 Vrms	1250 Vrms	N/A
Interrupt sources	DI 301 and 302	DI 301 and 302	N/A

**Table 4-2** Digital output product specifications for U2600A series DIO (U2651A, U2652A, and U2653A)

Digital Output			
Model Number	U2651A	U2652A	U2653A
Number of isolated bits	32-bit	N/A	64-bit
Output type	Open drain power MOSFET driver	N/A	Open drain power MOSFET drive
External supply voltage range	5 V to 35 V	N/A	5 V to 35 V
Voltage drop at MOSFET when on	$V_{Drop} < 1.0$ V	N/A	$V_{Drop} < 1.0$ V
Output sink current per bit	500 mA (100 % duty cycle) per bit, 400 mA (100% duty cycle) when full 32-bit loaded	N/A	500 mA (100 % duty cycle) per bit, 400 mA (100% duty cycle) when full 64-bit loaded
Isolation voltage	1250 Vrms	N/A	1250 Vrms

<sup>1</sup> Maximum input voltage range is 24 V with reference to COM pin

<sup>2</sup> Voltage level with reference to COM

## 4 Product Characteristics and Specifications

**Table 4-3** Power supply product specifications for U2600A series DIO (U2651A, U2652A, and U2653A)

<b>On Board Isolated +5 V Power Supply</b>			
<b>Model Number</b>	<b>U2651A</b>	<b>U2652A</b>	<b>U2653A</b>
Output voltage (Typical)	+5 V	N/A	+5 V
Output current (Typical)	150 mA	N/A	150 mA
Maximum power	0.85 W	N/A	0.85 W

**Table 4-4** General product specifications for U2600A series DIO (U2651A, U2652A, and U2653A)

<b>General Specification</b>			
<b>Model Number</b>	<b>U2651A</b>	<b>U2652A</b>	<b>U2653A</b>
User interface	Hi-speed USB 2.0		
Dimensions (W x D x H)	120.00 mm x 182.40 mm x 44.00 mm (with plastic casing)		
	105.00 mm x 174.54 mm x 25.00 mm (not including plastic cover)		
Connector type	100-pin SCSI-II connector		
Operating temperature	0 °C to +55 °C		
Storage temperature	-20 °C to +70 °C		
Relative humidity	Operating: 15 to 85% at 40°C non-condensing		
	Non-operating: 90% RH at 65°C for 24 hours		
Power consumption	+12 VDC at 235 mA typical	+12 VDC at 115 mA typical	+12 VDC at 260 mA typical



## 5 Dismantle Procedures

General Disassemble [62](#)

Mechanical disassemble [62](#)

Troubleshooting [66](#)

Self-Test Procedures [67](#)

This chapter describes the step-by-step disassemble procedures and list the available replacement parts for U2600A series DIO modules,



## General Disassemble

This chapter provides the step-by-step guides on how to dismantle the module and install the replacement assembly. To assemble back the module, follow the instructions in reverse order.

**NOTE**

The parts shown in the following figures are representative and may look different than what you have in your module.

The removable assemblies include:

- Plastic casing
- Metal casing
- Rear metal casing
- Front metal casing, which is attached to the carrier board and measurement board

## Mechanical disassemble

Follow the instructions in this section for the instrument disassemble process.

**Step 1: Pull the bumper out to remove the plastic casing.**

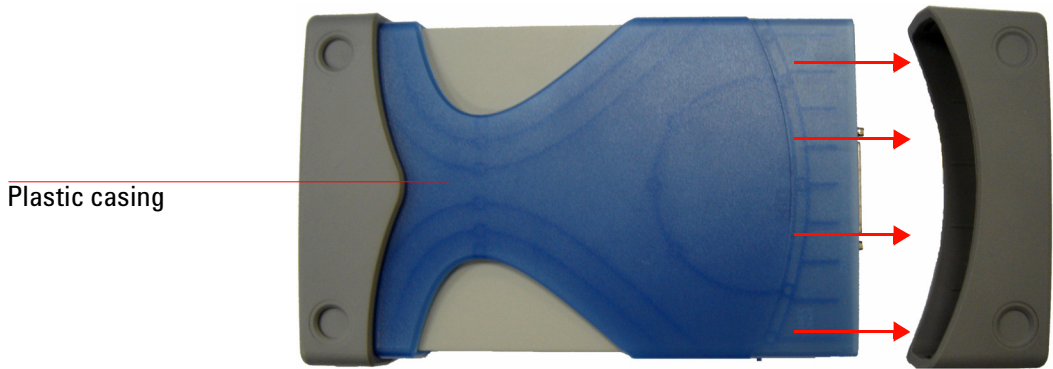

**Step 2: Flip the plastic casing open.**

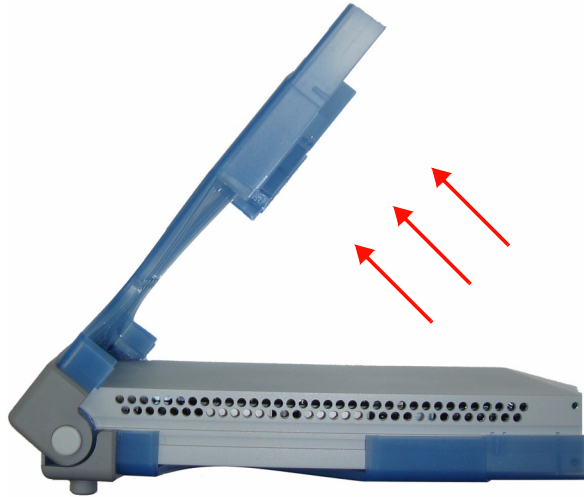

**Step 3: Slide the metal casing out of the plastic casing.**

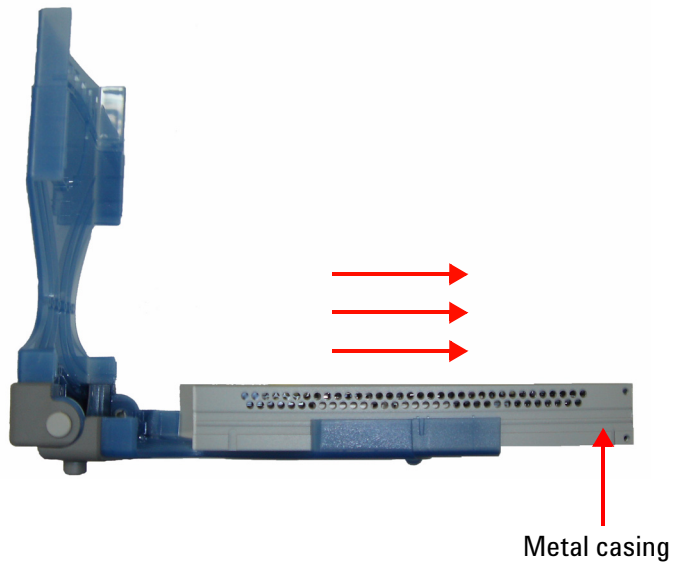

**Step 4: Unscrew all the following indicated screws from metal casing.**



**Step 5: Gently pull the front metal piece out, which is attached to the carrier and measurement boards.**

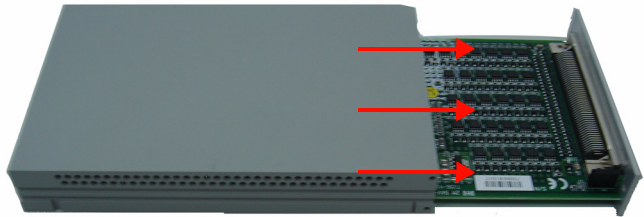

**Step 6: Unscrew all the following indicated screws from the metal casing and remove the rear metal piece.**



**Disassembled parts:**

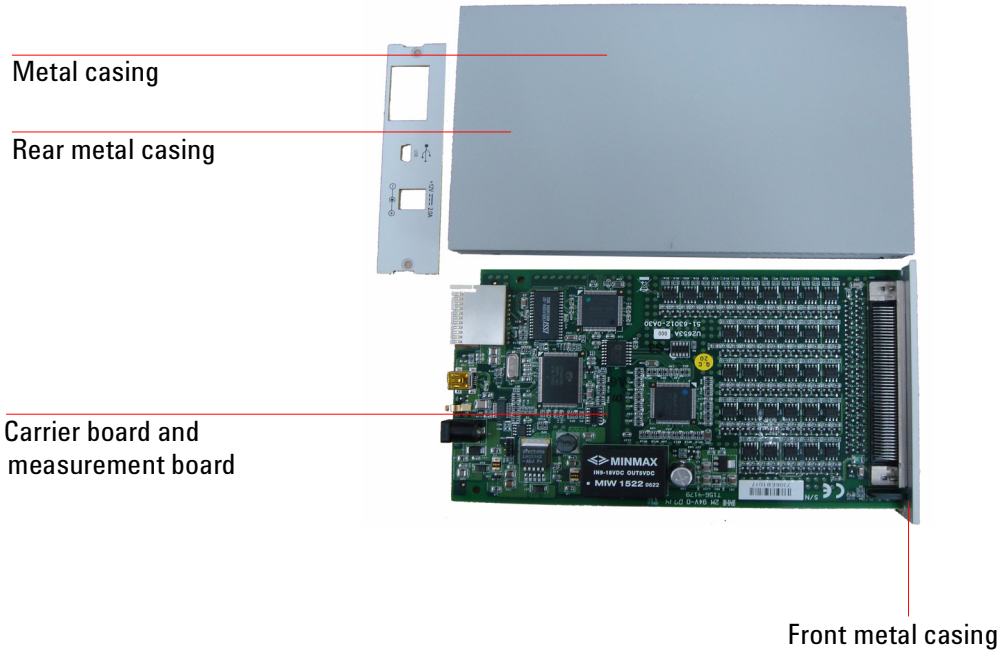

## Troubleshooting

This section provides suggestions for solving general problems that you may encounter with the instrument. It guides you on what to check in the following situations:

### 1 Power Indicator LED is not lit

Verify that the ac power cord is connected to the power inlet in the DAQ device.

### 2 Power Indicator LED is lit but the AO/ AI Indicator LED is not lit

Verify that the USB cable is connected to the PC and the USB inlet in the DAQ device.

### 3 Power Indicator LED is lit and AO/ AI Indicator LED is lit

Verify if the SCPI commands are correct with “SYSTem:ERRor?” command.

Refer to *U2600A Series USB Multifunction Programming Guide* for SCPI error messages.

#### NOTE

If there are no response from the instrument, contact the nearest Agilent Service Center to obtain further assistance.

---

## Self-Test Procedures

**WARNING**

Do not connect any cables and terminal block prior to performing self-test procedures.

---

- 1 Go to **Start > All Programs > Agilent IO Libraries Suite > Agilent Connection Expert** to launch the Agilent Connection Expert.
- 2 Go to **Start > All Programs > Agilent T&M Toolkit > Agilent Interactive IO** to launch the Interactive I/O dialog box.
- 3 Send the SCPI command “\*TST?” to the instrument to start perform the self-test of the instrument.
- 4 The command will return either "+0" to indicate all tests passes or "+1" to indicate one or more tests failed.
- 5 If the command returns "+1" , apply SCPI command “SYSTem:ERRor?” to enquire the error message.

**NOTE**

Refer to *Agilent U2600A Series USB Multifunction Data Acquisition Programming Guide* for SCPI error messages.

---

## **5 Dismantle Procedures**

**www.agilent.com**

**Contact us**

To obtain service, warranty or technical support assistance, contact us at the following phone numbers:

United States:

(tel) 800 829 4444 (fax) 800 829 4433

Canada:

(tel) 877 894 4414 (fax) 800 746 4866

China:

(tel) 800 810 0189 (fax) 800 820 2816

Europe:

(tel) 31 20 547 2111

Japan:

(tel) (81) 426 56 7832 (fax) (81) 426 56 7840

Korea:

(tel) (080) 769 0800 (fax) (080) 769 0900

Latin America:

(tel) (305) 269 7500

Taiwan:

(tel) 0800 047 866 (fax) 0800 286 331

Other Asia Pacific Countries:

(tel) (65) 6375 8100 (fax) (65) 6755 0042

Or visit Agilent worldwide web at:

[www.agilent.com/find/assist](http://www.agilent.com/find/assist)

Product specifications and descriptions in this document subject to change without notice.

© Agilent Technologies, Inc. 2007, 2009

Printed in Malaysia

Third Edition, September 1, 2009

U2651-90011



**Agilent Technologies**