

# Benchtop Multimeters

## MX 5006 - 6000pts

## MX 5060 - 60000pts

### User's Manual

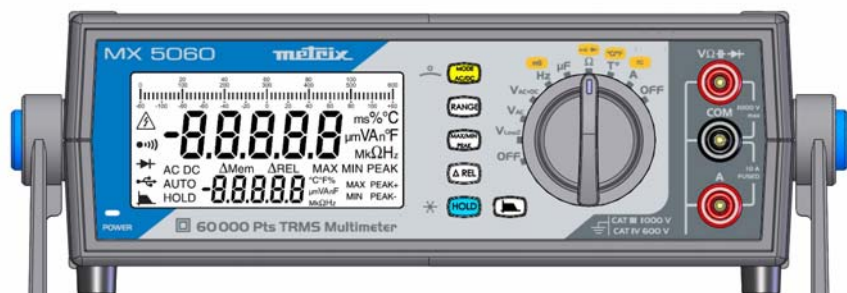

# Contents

<b>General directions</b> .....	<b>3</b>
Introduction.....	3
Precautions and safety measures .....	3
Symbols on the instrument.....	4
Warranty.....	5
Maintenance, metrological verification.....	5
Unpacking, repacking.....	5
Repair under warranty.....	5
<b>Service</b> .....	<b>6</b>
Maintenance.....	6
Replacing the fuse.....	6
Prop.....	6
Communication interface.....	6
<b>Description of the instruments</b> .....	<b>7</b>
MX 5006, MX 5060 front panel.....	7
MX 5006, MX 5060 back .....	7
<b>Functional description</b> .....	<b>8</b>
Display unit.....	8
Switch.....	10
Keypad .....	11
Preparation for use.....	16
<b>How are the various quantities measured?</b> .....	<b>17</b>
1. Voltage measurement .....	17
2. Current measurement.....	18
3. Frequency measurement.....	19
4. Resistance measurement.....	19
5. Audible continuity measurement.....	19
6. Diode test .....	20
7. Capacitance measurement.....	20
8. Temperature measurement.....	21
9. Measurement on an MLI type speed variator .....	22
<b>Technical characteristics of MX 5006</b> .....	<b>23</b>
<b>Technical characteristics of MX 5060</b> .....	<b>30</b>
<b>General characteristics</b> .....	<b>38</b>
Environmental conditions .....	38
Power supply.....	38
Display.....	38
Safety .....	38
CEM .....	38
<b>Mechanical characteristics</b> .....	<b>38</b>
Housing .....	38
<b>Supply</b> .....	<b>39</b>

## General directions

### Introduction



**Congratulations!** You are the new owner of a **benchtop multimeter**.

We thank you for this sign of confidence in the quality of our products.

The line of instruments to which it belongs comprises the following models:

<b>MX 5006</b>	6000pts	TRMS	-	
<b>MX 5060</b>	60000pts	TRMS	USB	Range 60mV

It complies with safety standard NF EN 61010-1 + NF EN 61010-2-030 concerning electronic measuring instruments.

For best results, read this manual closely and observe the precautions of use.

Failure to observe these warnings and/or directions may damage the instrument and/or its components and may endanger the user.

### Precautions and safety measures



- This instrument is been designed to be used as follows:
  - indoors
  - in an environment of pollution degree 2
  - at an altitude of less than 2000m
  - at a temperature between 0°C and 40°C
  - at a relative humidity below 80% up to 35°C.
- The safety of any system incorporating the instrument is the responsibility of the system integrator.
- It can be used for measurements on 1000V, CAT III and 600V, CAT IV circuits.  
However, some accessories may lead to the use of this instrument on circuits of a lower voltage and category.

#### before use

- Comply with the environmental and storage conditions.
- Check the integrity of the guards and insulation of the accessories. Any item of which the insulation is deteriorated (even partially) must be removed from service and scrapped. A change of colour of the insulation is a sign of deterioration.
- Supply: make sure that the power cord supplied with the instrument is in good condition. It must be connected to line power (230V  $\pm$ 10%, 300V, CAT II), (US version: 110V  $\pm$ 10%)
- The removable power cords must be replaced by cords having the appropriate rated characteristics.

#### during use

- Read closely all notes preceded by the  symbol.
- The instrument's power supply has an electronic protection device that resets automatically after the fault disappears.
- As a safety measure, use only the appropriate leads and accessories supplied with the instrument or approved by the manufacturer.

## General directions (continued)

### Definitions of the measurement categories



**CAT II:** Test and measurement circuits directly connected to the points of use of the low-voltage network (power outlets and other similar points).  
*E.g.: Measurements on the network circuits of household appliances, portable tools, and similar devices.*

**CAT III:** Test and measurement circuits connected to parts of the low-voltage network of the building.  
*E.g.: Measurements on distribution panels (including secondary meters), circuit-breakers, wiring including cables, bus bars, branch boxes, disconnecting switches, power outlets in the fixed installation, and industrial appliances and other equipment, such as motors permanently connected to the fixed installation.*

**CAT IV:** Test and measurement circuits connected to the source of the low-voltage network of the building.  
*E.g.: Measurements on devices installed before the main fuse or the circuit-breaker of the building installation.*

**Warning!** *Using a measuring instrument, a lead, or an accessory belonging to a lower measurement or voltage category derates the resulting system (instrument + leads + accessories) to the lowest measurement category and/or service voltage of any of the components.*

### Symbols on the instrument



Risk of electric shock: directions for connection and disconnection of the inputs. Always connect the probes or adapters to the instrument before connecting them to the measurement points. Always disconnect the probes or cords from the measurement points before disconnecting them from the instrument. These directions apply before the instrument is cleaned.



Warning: Hazard. The operator must refer to the manual each time this danger symbol is encountered.



Double insulation



Earth



In the European Union, this product is subject to selective collection for the recycling of electrical and electronic equipment waste in accordance with Directive WEEE 2002/96/EC: this equipment must not be treated as ordinary waste. The spent batteries must not be treated as ordinary waste. Take them in to the appropriate collection point for recycling.



The CE marking indicates conformity with the European "Low Voltage", "EMC", "WEEE" and "RoHS" directives.



USB (MX 5060, only)

## General instructions (continued)

---

### Warranty



This equipment is warranted for 3 years against any defect of materials or workmanship, in accordance with the general terms of sale. During the warranty period, the instrument may be repaired only by the manufacturer, who reserves the right to repair the instrument or to replace it or part of it. If the equipment is returned to the manufacturer, the cost of transport to the manufacturer is borne by the customer.

The **warranty** does not apply following:

- improper use of the equipment or use in association with incompatible equipment
- modification of the equipment without the explicit permission of the manufacturer's technical staff
- maintenance done by a person not approved by the manufacturer
- adaptation to a particular application not anticipated in the definition of the equipment or by the user manual
- a shock, a fall, or flooding.

---

### Maintenance, metrological verification

Before opening the instrument, you must disconnect it from line power and from the measurement circuits and make sure that you are not charged with static electricity, which might destroy internal components. An adjustment, maintenance, or repair of the live instrument must be undertaken only by personnel who are qualified and have familiarized themselves with the directions in this manual.



This instrument should be checked at least once a year. For checking and calibration, contact one of our accredited metrology laboratories (information and contact details available on request), at our Chauvin Arnoux subsidiary or the branch in your country.

---

### Unpacking, repacking



All of the equipment has undergone mechanical and electrical checks before being dispatched. When you receive it, carry out a quick check to detect any deterioration that may have occurred during transport. Should the need arise, immediately contact our sales department and notify the carrier of the customary reservations.

Use the original packaging to reship the equipment, if possible. Indicate as clearly as possible, by a note attached to the equipment, the reasons for the transfer.

---

### Repair under warranty and post warranty

For all repairs before or after expiry of warranty, please return the device to your distributor.

## Service

### Maintenance



- Disconnect everything connected to the instrument and set the switch to "OFF".
- Use a soft cloth, moistened with soapy water. Rinse with a damp cloth and dry rapidly with a dry cloth or forced air.
- Make sure that no foreign objects interfere with the operation of the device by which the leads are snapped into place.

### Replacing the fuse

- Before replacing the fuse, disconnect the instrument from any source of current.
- Checking the current fuse:
  1. Set the switch to OFF.
  2. Connect the V socket to the 10A socket; leave the "COM" socket open.
  3. The display unit must indicate a result  $< 2 \Omega$ , if not, replace the fuse.
- Access to and location of the **fuse**, by opening the housing:

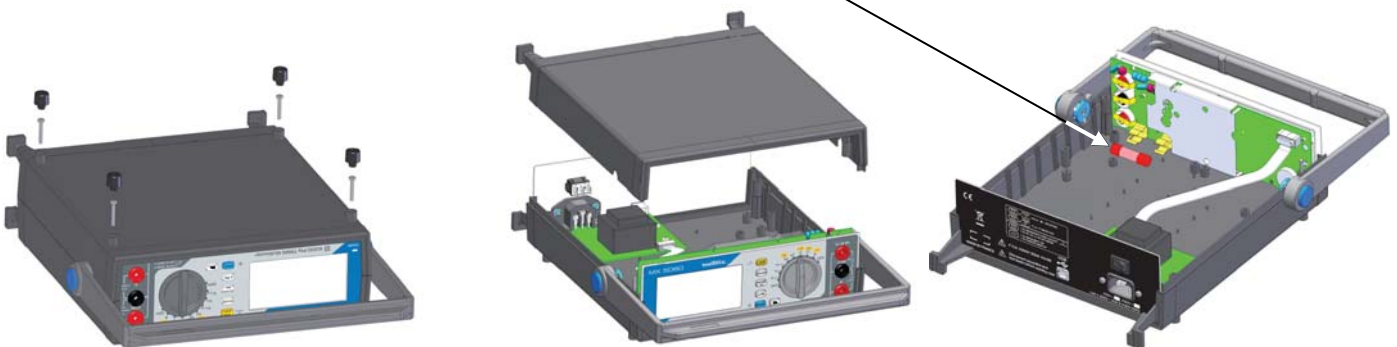
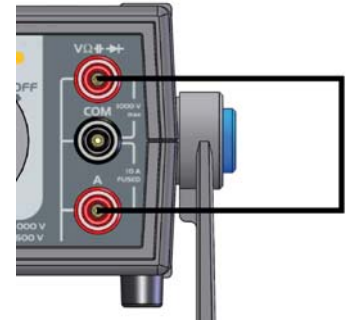

- Current protection: fuse, 11A, 1000V > 20kA (10x38)
- Power supply protection: PTC

### Tilt stand

The tilt stand/handle has 2 blue pushbuttons on the sides that are used to unlock it:

- Press the pushbuttons simultaneously
- Adjust the prop to the desired position
- Release the 2 pushbuttons to lock the handle in position

### Communication interface



The **MX 5060** has a USB communication interface, used:

- to configure and read the data measured by the instrument (using SX-DMM software),
- to recalibrate the instrument.

☞ **The MX5006 does not have a USB communication port. Only an RS link is available to calibrate the instrument (after opening it).**

## Description of the instruments

### Front panel

**MX 5006**

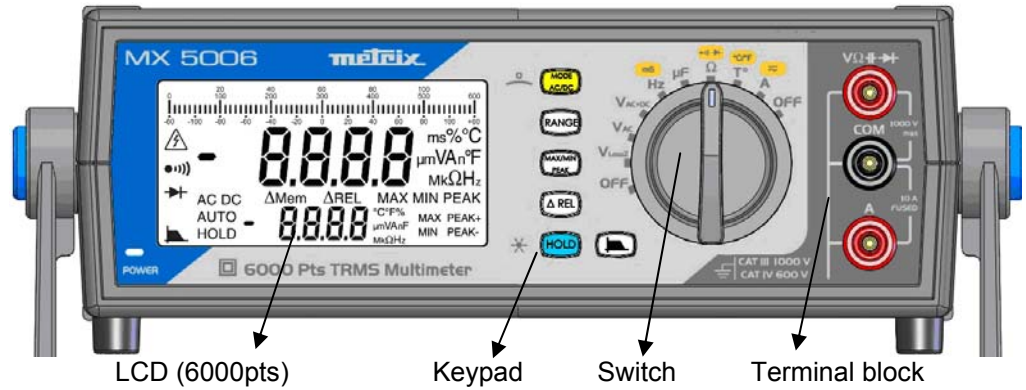

**MX 5060**

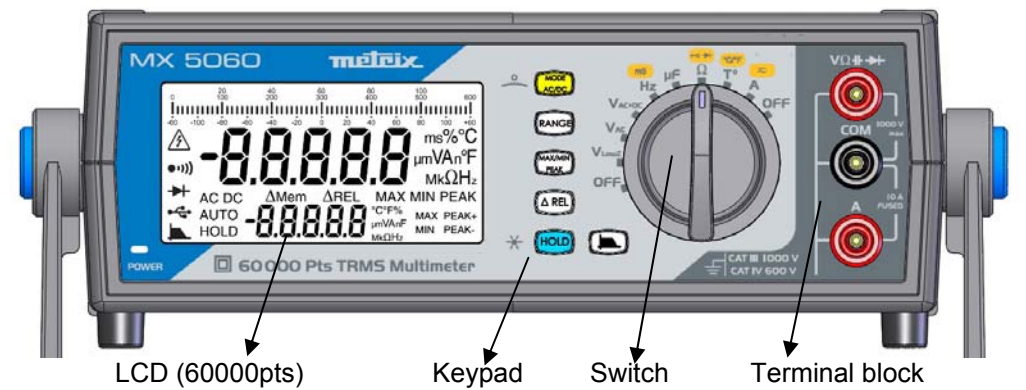

### Rear panel

**MX 5006**

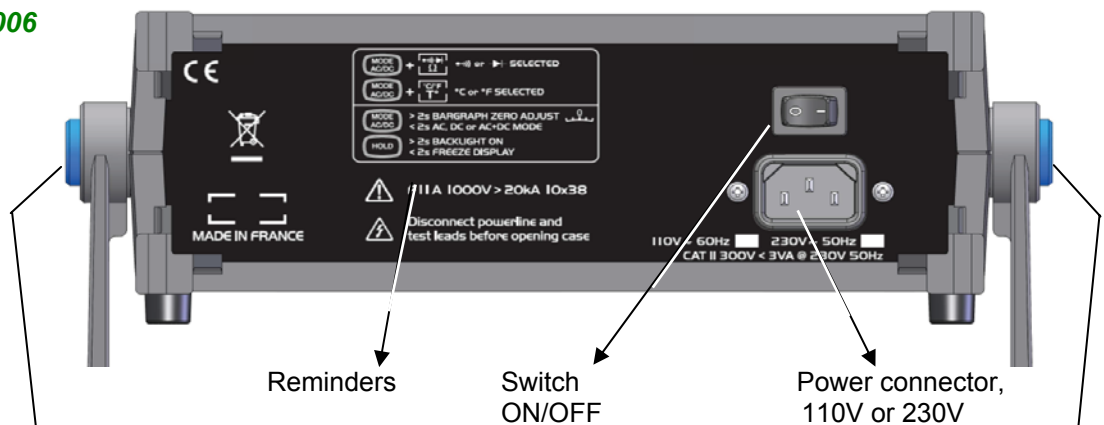

**MX 5060**

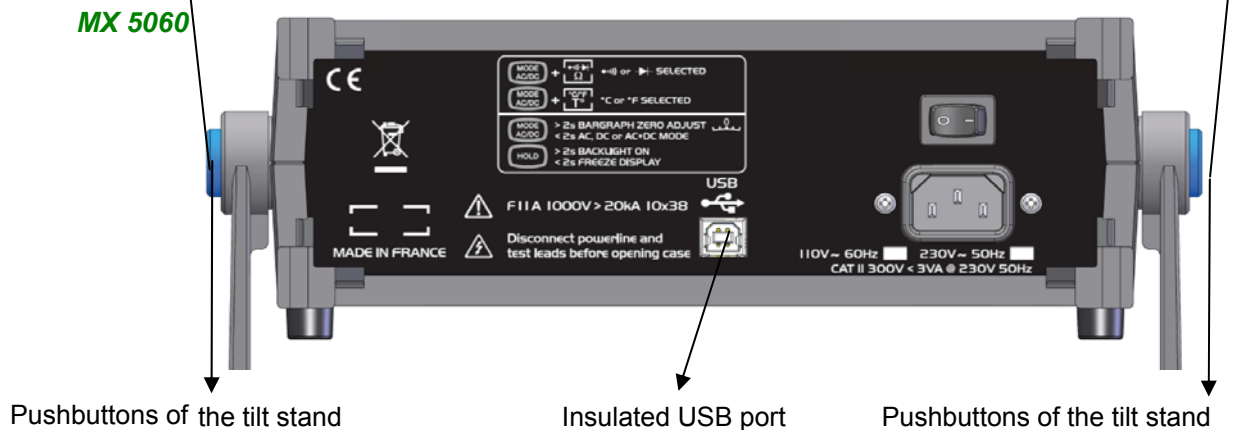

## Functional description

### Display unit

**MX 5006**  
double display  
6000pts

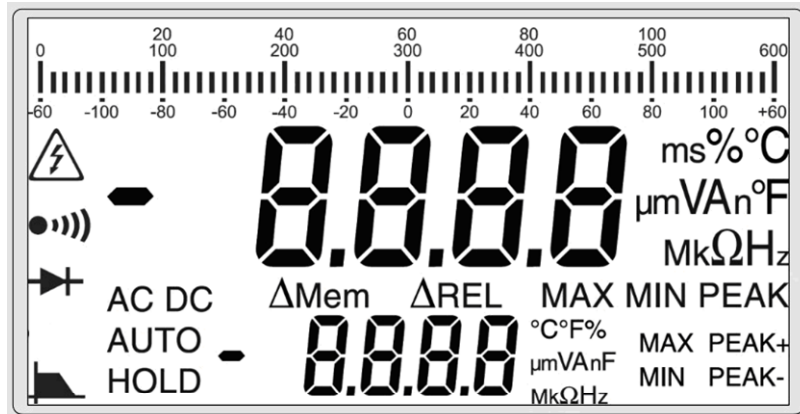

**MX 5060**  
double display  
60000pts

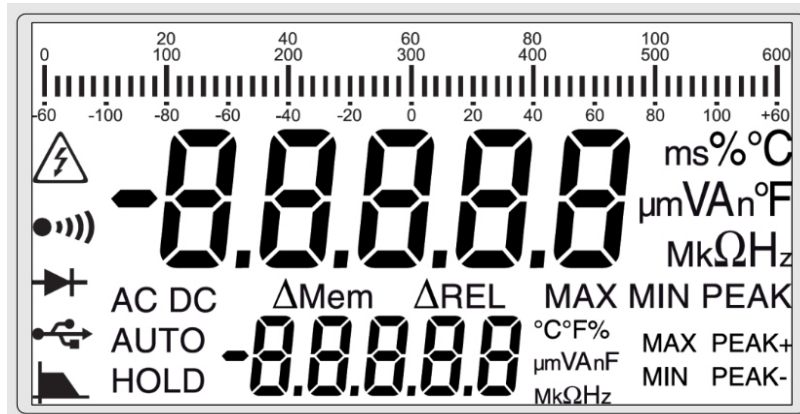





### Quantities measured

- V<sub>LowZ</sub> AC voltage measurement at low impedance (V<sub>LowZ</sub>)
- V<sub>AC</sub> AC voltage measurement
- V<sub>AC/DC</sub> DC or AC+DC voltage measurement at high impedance (V)
- A Current measurement A
- Hz Frequency measurement
- Ω Resistance measurement
- μF Capacitance measurement
- T° Temperature measurement
- ms Measurement of the period
- % Measurement of relative value

### Units

- V Volt
- A Ampere
- Hz Hertz
- Ω Ohm
- F Farad
- °F Degree Fahrenheit
- °C Degree Celsius
- ms millisecond
- k kilo (kΩ - kHz)
- M Mega (MΩ - MHz)
- n nano (nF)
- μ micro (μV- μA - μF)
- m milli (mV- mA - mF)
- % Percentage

## Functional description (continued)

<b>Symbols</b>	<b>Designation</b>
<b>AC</b>	Measurement of the RMS AC signal
<b>DC</b>	Measurement of the DC signal
<b>AC + DC</b>	Measurement of the TRMS AC and DC signal
<b>AUTO</b>	Automatic range switching
<b>ΔREL</b>	Values relative to a reference
<b>ΔMem</b>	Presence of a reference value in memory
<b>HOLD</b>	Storage and display of stored values
<b>MAX</b>	Maximum value
<b>MIN</b>	Minimum value
<b>PEAK+</b>	Maximum peak value
<b>PEAK-</b>	Minimum peak value
<b>.run r.un ru.n</b>	Capacitance meter, acquisition in progress
<b>----</b>	Frequency measurement impossible
<b>O.L</b>	Overshoot of the measurement capacities
<b>V</b>	Volt
<b>Hz</b>	Hertz
<b>F</b>	Farad
<b>°C °F</b>	Degree Celsius, degree Fahrenheit
<b>A</b>	Ampere
<b>%</b>	Percentage
<b>Ω</b>	Ohm
<b>ms</b>	millisecond
<b>n</b>	Symbol of the nano- prefix
<b>μ</b>	Symbol of the micro- prefix
<b>m</b>	Symbol of the milli- prefix
<b>k</b>	Symbol of the kilo- prefix
<b>M</b>	Symbol of the mega- prefix
	Symbol of the audible continuity measurement
	Symbol of the measurement and testing of a semiconductor junction
	Warning, possibility of electric shock (*)
	USB communication
	300Hz MLI filter

(\*)When voltages exceeding 60 VDC or 25 VAC are measured, the symbol flashes on the display unit.

## Functional description (continued)

### Switch

The switch setting determines the measurement function chosen. The rotation of the switch has priority over key presses. The change from one position to another resets the configuration of the measurement mode.

The change from one measurement function to another deactivates the **HOLD** key, if the **HOLD** mode was selected.

The switch has 10 positions:

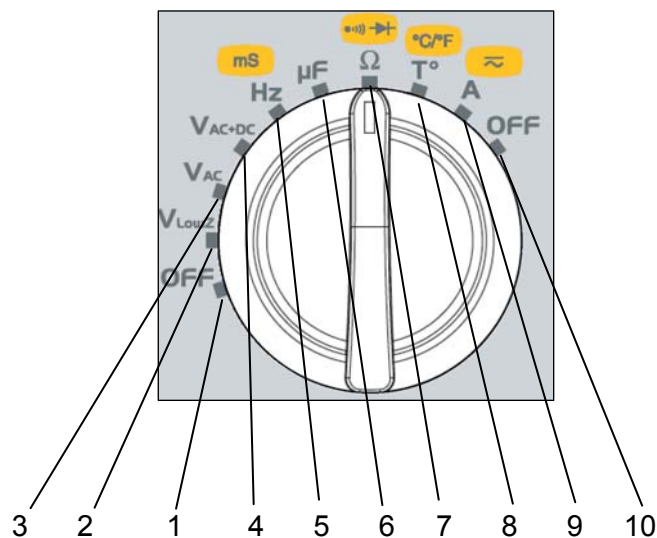

1. OFF mode - Switches the multimeter off
2. AC voltage measurement at low impedance (V<sub>LowZ</sub>)
3. RMS AC voltage measurement
4. DC or AC+DC voltage measurement at high impedance (V)
5. Frequency measurement
6. Capacitance measurement
7. Resistance measurement, audible continuity measurement, diode test
8. Temperature measurement T, K
9. Current measurement A (AC, DC, or AC+DC)
10. OFF mode - Switches the multimeter off

## Functional description (continued)

### Keypad

The keypad has the following function keys:

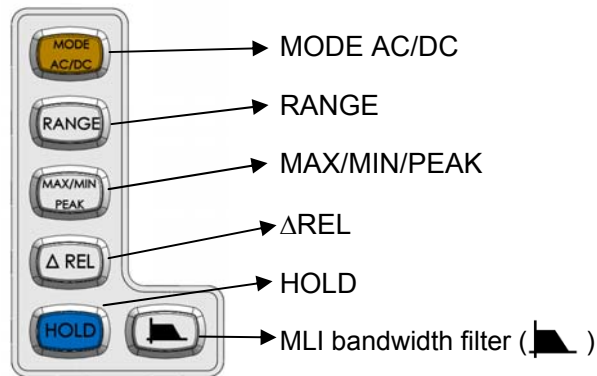

The keys are taken into account and applied when pressed. If the key press is validated, the instrument beeps.

**General rules** For the keys, 2 types of possible action are distinguished:

- **Short press:** key press lasting less than 2 seconds, validated by a beep as soon as the key press is detected.
- **Long press:** key press lasting more than 2 seconds, validated by a beep as soon as the key press is detected.



Choice of coupling, **AC**, **DC**, **AC+DC**, of the bargraph style, or of the secondary function key of the keypad (yellow).



Manual selection of the measurement range. The range defines the maximum measurement span the instrument can cover.

 **The Auto Range mode is activated as default.**



Display of the MAX, MIN, PEAK+, or PEAK- mode:

- **MAX** and **MIN** display the highest and lowest value of the RMS measurement.
- **PEAK+** displays the maximum peak instantaneous value of the measurement.
- **PEAK-** displays the minimum peak instantaneous value of the measurement.



Storage of the measurements and quantities at a given time. Freezes the display without stopping acquisition. The bargraph continues to operate normally. The key is used to deactivate back-lighting of the instrument.



Display and storage of the reference value of the differential value in the unit of the quantity measured.











This key is used to limit the bandwidth to  $\approx 300\text{Hz}$ .

Thanks to the low-pass filter (4th order), it is possible to measure the RMS voltage delivered by an MLI type speed variator (for asynchronous motor).

See curves p. 29 and 37.

## Functional description (continued)

Summary table of the keys	Successive short presses	Long press
<b>AC/DC MODE</b> 	-Choice of AC, DC, or AC+DC coupling -Access to the second function (yellow marking on the front panel) -In the ΔREL or MAX/MIN PEAK plus ΔREL mode, the key is used to go from (present value - reference value) to <div style="border: 1px solid black; padding: 5px; margin: 10px 0;"> <math display="block">\frac{\text{present value} - \text{reference value}}{\text{reference value}} \times 100</math> </div> The value is displayed in %.	Choice of bargraph style:  Bargraph graduated from zero to full scale or with central zero
<b>RANGE</b> 	-Manual selection of the measurement range -Exit from the MAX/MIN, PEAK mode	Exit from the manual mode to return to auto range (the default)
* <b>MAX/MIN PEAK</b>  (*) See example on p. 13	-1 <sup>st</sup> press: recording of MAX, MIN, PEAK+, PEAK- (on the 2nd display unit). The max. value is displayed as default. - Subsequent presses: look-up of recorded values	Exit from the MAX/MIN PEAK mode
<b>HOLD</b> 	-Activation/deactivation of freezing of the display. Acquisition continues as a background task. <i>In the MAX/MIN PEAK mode, when HOLD is active, the blinking of the "MAX MIN PEAK" symbol indicates that acquisition continues as a background task.</i>	On/off switching of the backlight 
* <b>ΔREL</b>  (*) See example on p. 14	-1 <sup>st</sup> press: activates the relative mode ΔREL $\left[ \frac{\text{present value} - \text{reference value}}{\text{reference value}} \right]$ and stores the measured value, which will be used as reference. "ΔMem" indicates storage of the reference. -Subsequent presses: toggles the display between measured value, reference, and relative measurement ΔREL, reference for look-up.	Exit from the ΔREL mode and erasure of the reference value (the ΔMem symbol goes off)
	Activation of the 300Hz bandwidth filter	Activation/deactivation of the key-press beep

The , , , , , and  functions can be accessed by successive short or long presses on a key (see table above). The functions are not mutually exclusive; they can be combined.

It is therefore possible to implement MAX/MIN PEAK in relative or pure relative only. Similarly, the HOLD mode applies to all functions and does not interfere with MAX/MIN PEAK surveillance; all it does is freeze the display. Each press is validated by an audible signal.

## Functional description (continued)

### MAX/MIN PEAK mode

*Examples of display in the VAC+DC function* Measured signal: 230V, 50Hz:

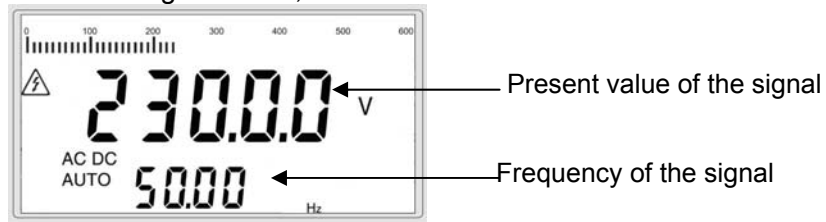

*for the MAX value:* First press on the **MAX/MIN PEAK** key:

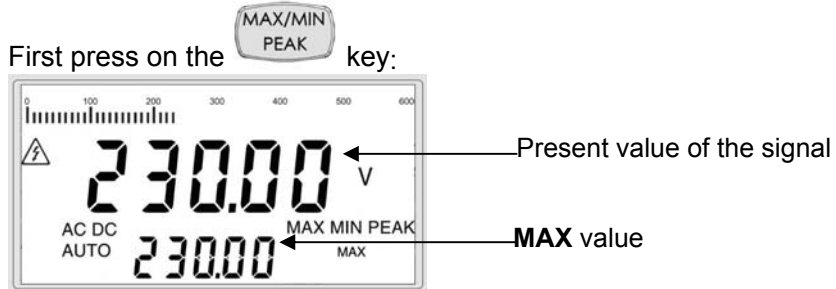

The measured signal changes to 250V, 50Hz:

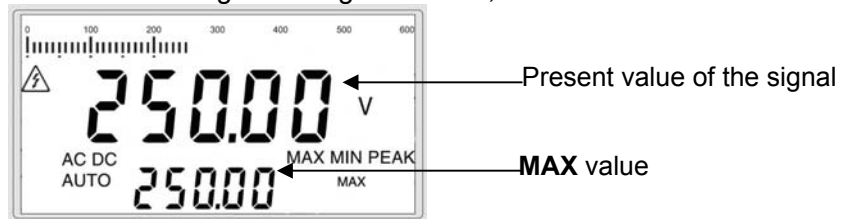

*for the MIN value:* Second press on the **MAX/MIN PEAK** key:

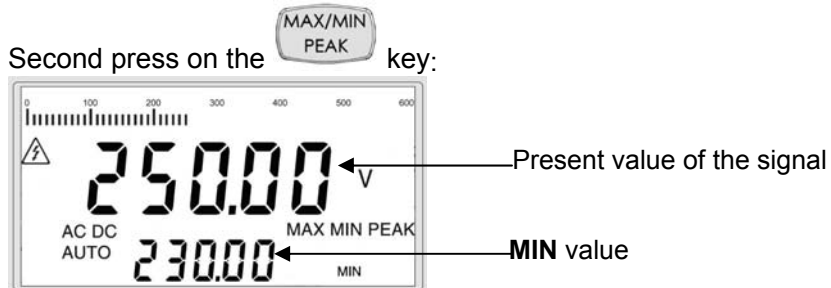

*for the PEAK+ value:* Third press on the **MAX/MIN PEAK** key:

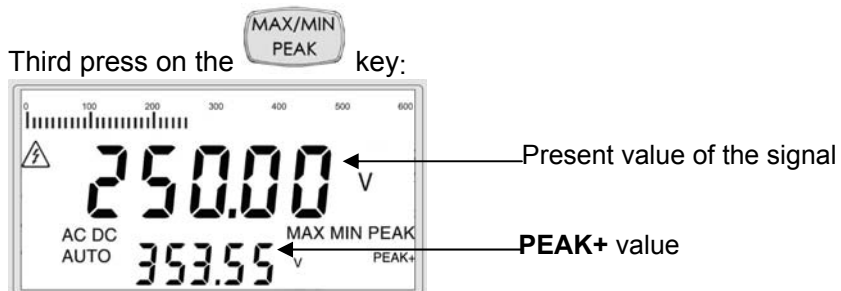

*for the PEAK- value:* Fourth press on the **MAX/MIN PEAK** key:

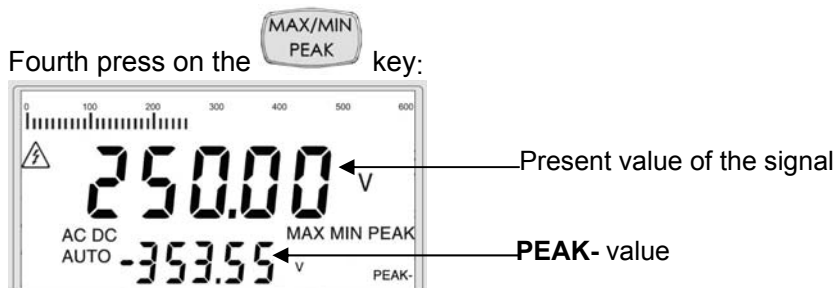

## Functional description (continued)

### Mode $\Delta$ REL

Examples of display  
in the VAC+DC  
function

Measured signal: 1V, 100Hz:

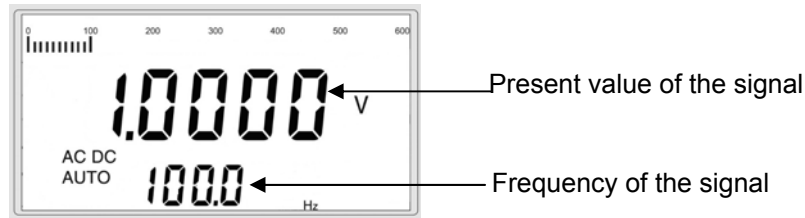

Activation of the  
 $\Delta$ REL mode by

a short press on the  $\Delta$  REL key:

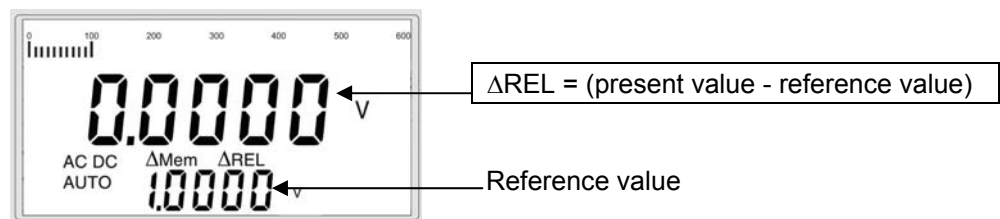

The signal changes to 1.5V ( $\Delta$ REL = 1.5V-1V = 0.5V)

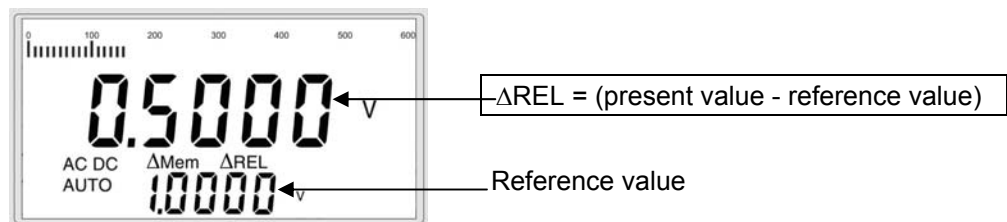

De-activation of the  
 $\Delta$ REL mode by

a press on the  $\Delta$  REL key:

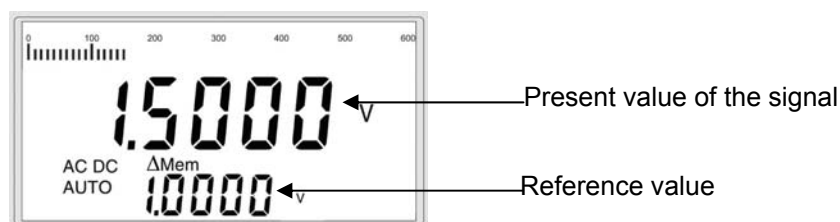

A long press on the  $\Delta$  REL key erases the reference value and exits from the  $\Delta$ REL mode.

Short press, in the  $\Delta$ REL mode, on the MODE AC/DC key:

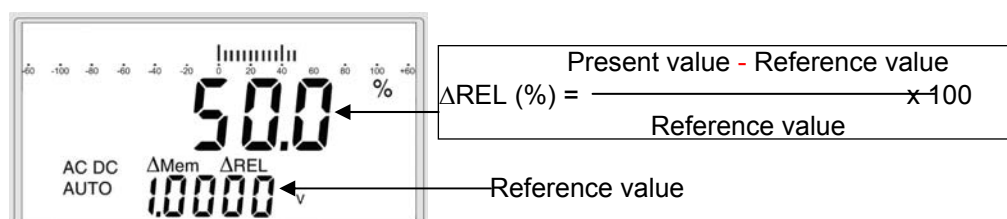



## Functional description (continued)

### Functions of the switch and keys

To access the  $V_{LowZ}$ ,  $V_{AC}$ ,  $V_{AC+DC}$ ,  $Hz$ ,  $\Omega$ ,  $\mu F$ ,  $T^\circ$ , and  $A$  functions, set the switch to the function chosen.

Here are the possible combinations according to the type of measurement:

Type of measurement	Max/Min	Peak $\pm$	$\Delta REL$		Range		HOLD	
					Auto.	Manu.		
Voltage $V_{LowZ}$ Voltage $V_{AC}$ Voltage $V_{AC+DC}$ Current $A_{AC}$ , $A_{AC+DC}$	✓	✓	✓	in $\Delta REL$ <i>only</i>	✓	✓	✓	✓
Voltage $V_{DC}$ Current $A_{DC}$	✓	-	✓	✓	✓	✓	✓	-
Voltage 60mV $_{DC}$	✓	-	✓	✓	-	✓	✓	-
Voltage 60mV $_{AC}$ Voltage 60mV $_{AC+DC}$	✓	✓	✓	in $\Delta REL$ <i>only</i>	-	✓	✓	✓
Temperature	✓	-	✓		✓	✓	✓	-
Ohmmeter	✓	-	✓		✓	✓	✓	-
Capacitance	✓	-	✓		✓	✓	✓	-
Frequency	✓	-	✓		✓	-	✓	-
Period (1/F)	-	-	-	-	✓	-	✓	-
Continuity	-	-	-	-	✓	-	-	-
Diode	-	-	-	-	✓	-	✓	-

## Functional description (continued)

### Preparation for use

#### *Instructions before starting up*

When you use this multimeter, you must observe the usual safety rules, which:

- protect you from electrical hazards,
- protect the multimeter from operator errors.

For your safety, use only the leads supplied with the instrument. Before each use, make sure that they are in perfect condition.

#### *Power supply*

line power at 230V  $\pm$ 10% (US version, 110V  $\pm$ 10%) ; 45Hz to 65Hz

The power connector is on the back of the instrument. (The earth connection serves to carry currents to earth).

#### *Powering up, down*

Use the power On/Off switch on the back of the instrument to power it up.

A check light on the front of the instrument indicates that it is powered up.

#### *Switching on*

The switch is set to «**OFF**». Turn the switch to the function of your choice. All segments of the display unit light for a few seconds, then the screen of the function selected is displayed.

The multimeter is then ready to perform measurements.



- *Starting up accompanied by a simultaneous sustained press on the HOLD key (until it beeps) lights all segments of the display unit*
- *A second, short, press displays:*
  - *the hardware version (A, B, C, etc.),*
  - *the software version*
  - *the instrument model (MX 5006 or MX 5060).*
- *A third short press is used to exit from the mode.*

#### *Switching to standby*

Set the switch to “**OFF**”.

## How are the various quantities measured?

### 1. Voltage measurement

**V<sub>AC+DC</sub>**: AC voltage measurement, or measurement of an AC voltage superposed on a DC voltage, or DC voltage measurement at high impedance.

**V<sub>AC</sub>**: AC voltage measurement at high impedance

**V<sub>LowZ</sub>**: This position is provided to allow measurements in electrical installations. The input impedance  $<1\text{M}\Omega$  serves to avoid measuring "phantom" voltages due to couplings between the lines.

In all cases, "O.L" is displayed above 1050V and a beep sounds when the measurement exceeds 600V.

1. Set the switch to **V<sub>LowZ</sub>** or **V<sub>AC+DC</sub>** or **V<sub>AC</sub>**.

2. Select AC+DC or DC coupling of the signal by pressing **MODE AC/DC** (the default coupling is AC+DC).

Depending on what you select, the screen displays DC or AC+DC.

3. Connect the black lead to the "COM" terminal and the red lead to "+".

4. Place the test probes on the terminals of the circuit to be measured:

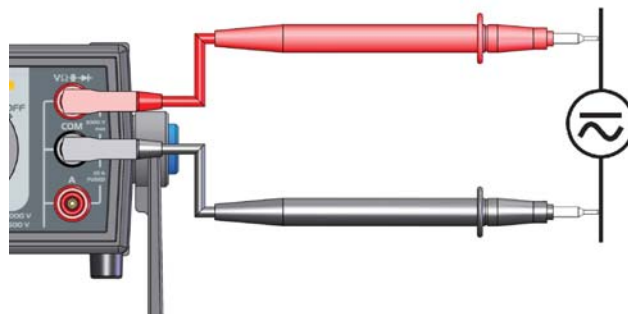

5. Read the measurement value indicated on the display unit.

6. As default, the 2nd display unit indicates the frequency, except in DC.

**Remark:** *It is possible to activate the **filter** in **V<sub>LowZ</sub>**, **V<sub>AC+DC</sub>**, **V<sub>AC</sub>**. The cutoff frequency of the filter is  $\leq 300\text{Hz}$ .*

*When a voltage having a frequency above 150Hz is measured, it is heavily attenuated, and so a large error may be observed. It is necessary in this case to deactivate the filter to have the full bandwidth.*

## How are the various quantities measured? (continued)

### 2. Current measurement

1. Set the switch to **A**.
2. Select the type of signal, AC+DC, AC, or DC, by pressing **MODE AC/DC**. Depending on what you select, the screen displays AC, DC, or AC+DC.
3. Connect the black lead to the "COM" terminal and the red lead to "A".
4. Place the test probes in series between the source and the load:

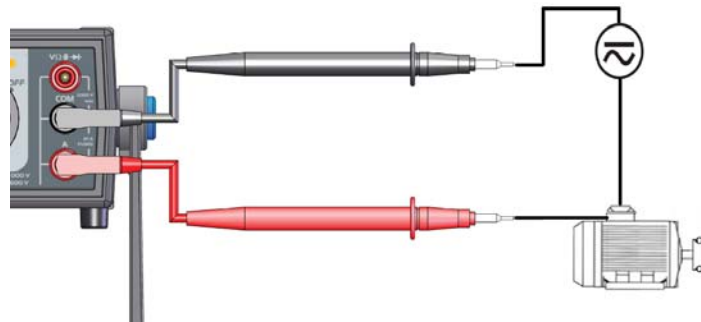
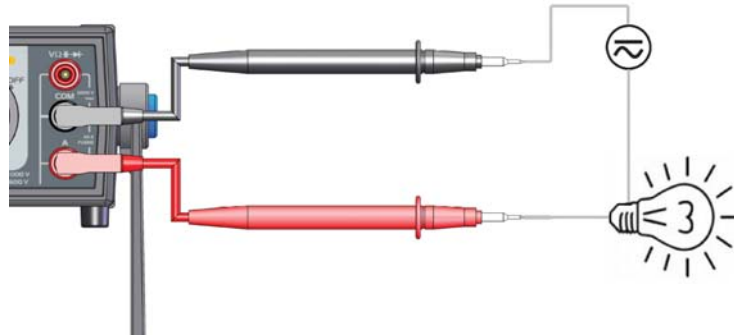

5. Read the measurement value indicated on the display unit.  
"O.L." is displayed, if  $I > 20A$ .
6. As default, the 2nd display unit indicates the frequency, except in DC.

**Remark:** *It is possible to activate the  filter in AAC+DC, AAC. The cutoff frequency of the filter is  $\leq 300Hz$ .*

*When a voltage having a frequency above 150Hz is measured, it is heavily attenuated, and so a large error may be observed. It is necessary in this case to deactivate the filter to have the full bandwidth.*

## How are the various quantities measured? (continued)

### 3. Frequency measurement

1. Set the switch to  .
2. Connect the black lead to the “COM” terminal and the red lead to “+”.
3. Place the test probes on the terminals of the circuit to be measured.

 **Connect the instrument as for a voltage measurement**

4. Read the measurement value indicated on the display unit.
5. Press  to obtain the period of the signal 1/F (ms).

### 4. Resistance measurement

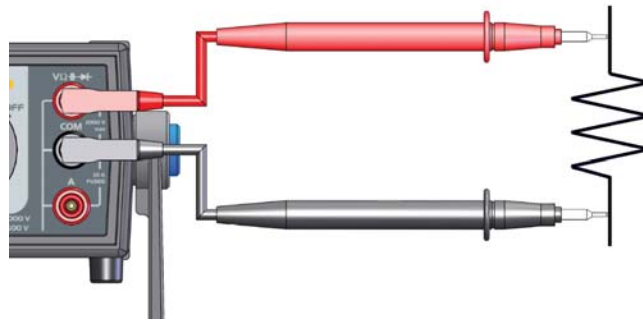

1. Set the switch to  .
2. Connect the black lead to the “COM” terminal and the red lead to “+”.
3. Place the test probes on the terminals of the component.

**Remark: Resistance measurements must be made with power off. However, while the presence of a voltage will prevent or throw off the measurement, it will not damage the instrument.**



4. Read the measurement value indicated on the display unit.
5. “O.L” is displayed, if the circuit is open.

### 5. Audible continuity measurement



1. Set the switch to  .
2. Press  ; the “” symbol is displayed.
3. Connect the black lead to the “COM” terminal and the red lead to “+”.
4. Place the test probes on the terminals of the circuit to be measured.

 **Connect the instrument as for a voltage measurement.**

5. Read the measurement value indicated on the display unit.
6. The continuity beep sounds when  $R < 30\Omega \pm 3\Omega$ .
7. “O.L” is displayed, if the circuit is open.

## How are the various quantities measured? (continued)

### 6. Diode test

1. Set the switch to .
2. Press  twice; the “” symbol is displayed.
3. Connect the black lead to the “COM” terminal and the red lead to “+”.
4. Place the test probes on the terminals of the component:

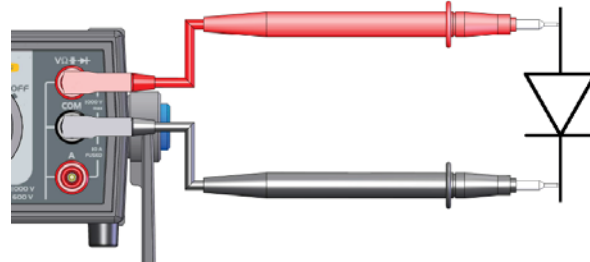

5. Read the measured threshold voltage of the junction indicated on the display unit.
6. “O.L.” is displayed, if the circuit is open or the threshold of the diode  $>3V$ .

### 7. Capacitance measurement

1. Set the switch to .
2. Connect the black lead to the “COM” terminal and the red lead to “+”.
3. Place the test probes on the terminals of the component:

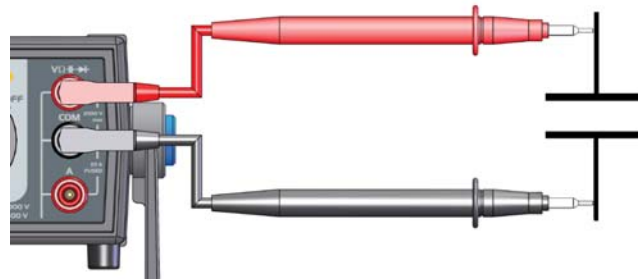

4. Read the measurement value indicated on the display unit.
    - “O.L.” is displayed, if the value to be measured exceeds the capacitance of the range.
    - “O.L.” is displayed, if the capacitor is short-circuited.
- For high values, the measurement cycle includes the display of "run" with a "chaser" decimal point. This means that acquisition is in progress; wait for the display of the digital result.



***“Run” is displayed immediately, if the previous measurement was in a small range.***

- The prior discharge of very high capacitances helps shorten the measurement time.

## How are the various quantities measured? (continued)

### 8. Temperature measurement

1. Set the switch to **T°**.
2. Press **MODE AC/DC** to switch the temperature unit (°C or °F) between the two display units.  
  
**The unit displayed as default on the main display unit is °C.**
3. Connect the temperature probe (K thermocouple) to the “COM” and “+” terminals, bearing the polarity in mind:

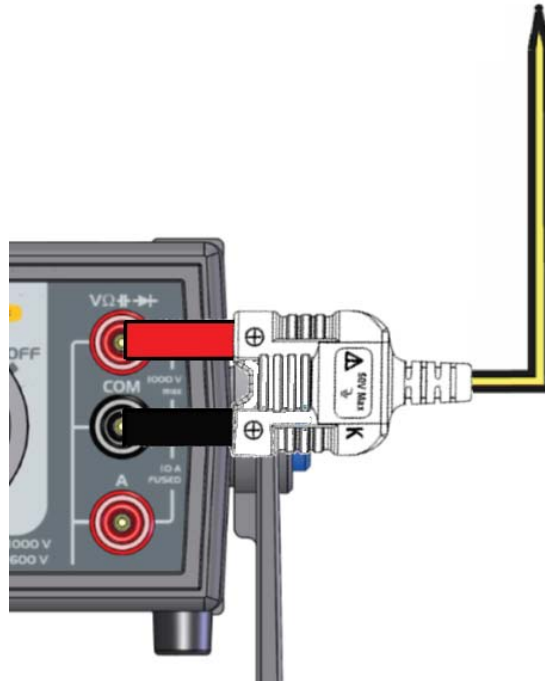

4. Read the measurement value indicated on the display unit.



If “O.L” is displayed, the thermocouple is open-circuit or the value to be measured exceeds the capacitance of the range.  
If the inputs are short-circuited, the instrument displays the ambient temperature.

**Remark:** For greater accuracy, avoid exposing the instrument to sudden changes of temperature.

## How are the various quantities measured? (continued)

### 9. Measurement on an MLI type speed variator

#### Voltage measurement

1. Set the switch to .
2. Select the filter by pressing .
3. Connect the black lead to the "COM" terminal and the red lead to "+".
4. Place the test probes between two phases of the circuit to be measured:

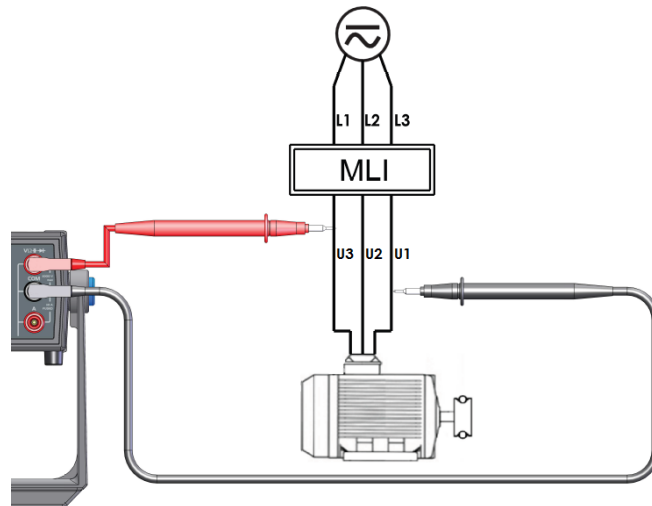

5. Read the measurement values indicated on the display unit (voltage and frequency):
  - “O.L” is displayed above 1050V and a beep sounds when the measurement exceeds 600V.
  - The presence of the  symbol indicates that the filter is active.

**Remark:** *It is very important to leave the filter activated to measure the voltage and frequency of the signal without being perturbed by the MLI.*

## Technical characteristics of the MX 5006

**Accuracy:** Only values with tolerances or limits are guaranteed values.  
 "n% + nD" means Values without tolerances are given for guidance (standard NFC42670).  
 "n% of the reading + n Digit" The technical specifications are guaranteed only after 30 minutes of warming up. Except as otherwise indicated, they are valid from 5% to 100% of the measurement range.  
 (cf. CEI485)

### VOLTAGES

Protection: 1414Vpk

#### DC voltage

V<sub>DC</sub>

Range	Specified measurement range	Resolution	Intrinsic error
600mV	0 to 600.0mV	0.1mV	0.5% L + 2 D
6V	0 to 6.000V	0.001V	0.09% L + 2 D
60V	0 to 60.00V	0.01V	
600V	0 to 600.0V	0.1V	
1000V *	0 to 1000V	1V	

(\* ) The display indicates "+OL" above +1050V and "-OL" below -1050V.

#### AC voltage

V<sub>LowZ AC RMS</sub>

The bandwidth is reduced to 300Hz if the filter is activated. The frequency measurement is made like a measurement in a 300Hz PB.

Range	Operating range	Specified measurement range <sup>3)</sup>	Resolution	Uncertainty (±)	Additional uncertainty F (Hz) <sup>1)</sup>	Input impedance // < 50 pF	Peak factor
600mV	0 to 600.0mV	60.0 to 600.0mV	0.1mV	1.2% L + 0.25% x [F(kHz)-1] L ±5 D	45<F<65Hz 0.3% L typ.	≅ 520kΩ	3 to 500mV
6V	0 to 6.000V	0.600 to 6.000V	0.001V	1.2% L + 0.18% x [F(kHz)-1] L ±3 D	at 100Hz 0.7% L typ.		3 to 5V
60V	0 to 60.00V	6.00 to 60.00V	0.01V		at 150Hz 1.8% L typ.		3 to 50V
600V	0 to 600.0V	60.0 to 600.0V	0.1V		at 300Hz 30% L typ.		3 to 500V
1000V <sup>2)</sup>	0 to 1000V	60 to 1000V	1V				1,42 to 1000V

1) See the typical curve of the 300Hz filter on p. 29.

2) The LCD indicates "+OL" above +1050V, "-OL" below -1050V or above 1050VRMS.

3) From 1kHz, the measurement must exceed 15% of the range

Secondary measurements and displays: FREQ (AC coupling), MAX, MIN, PEAK

## Technical characteristics of the MX 5006 (continued)

### VAC RMS

Range	Operating range	Specified measurement range <sup>3)</sup>	Resolution	Uncertainty (±)	Additional uncertainty F (Hz) <sup>1)</sup>	Bandwidth	@ 1kHz Input impedance // < 50 pF	Peak factor		
600mV	0 to 600.0mV	60.0 to 600.0mV	0.1mV	1% L + 0.25% x [F(kHz)-1]L ±5 D	45<F<65Hz 0.3% L typ.	10Hz to 50kHz	10.9MΩ	3 to 500mV		
6V	0 to 6.000V	0.600 to 6.000V	0.001V	1% L + 0.18% x [F(kHz)-1]L ±3 D	at 100Hz 0.7% L typ.	10Hz to 100kHz	10.9MΩ	3 to 5V		
60V	0 to 60.00V	6.00 to 60.00V	0.01V		at 150Hz 1.8% L typ.		10.082MΩ	3 to 50V		
600V	0 to 600.0V	60.0 to 600.0V	0.1V		at 300Hz 30% L typ.		10.008MΩ	3 to 500V		
1000V <sup>2)</sup>	0 to 1000V	60 to 1000V	1V						10.008MΩ	1.42 to 1000V

1) See the typical curve of the 300Hz filter on p. 29.

2) The LCD indicates "+OL" above +1050V, "-OL" below -1050V or above 1050VRMS.

3) From 1kHz, the measurement must exceed 15% of the range

Secondary measurements and displays: FREQ (AC coupling), MAX, MIN, PEAK

### AC and DC voltage AC+DC TRMS

Range	Operating range	Specified measurement range <sup>3)</sup>	Resolution	Uncertainty DC (±)	Uncertainty AC (±)	Additional uncertainty F (Hz) <sup>1)</sup>	Bandwidth	Input impedance // < 50 pF	Peak factor
600mV	0 to 600.0mV	60.0 to 600.0mV	0.1mV	0.8% L ±10 D	0.8% L + 0.18% x [F(kHz)-1]L ±5 D	45<F<65Hz 0.3% L typ.	10Hz to 50kHz	10.9MΩ	3 to 500mV
6V	0 to 6.000V	0.600 to 6.000V	0.001V		at 100Hz 0.7% L typ.	10Hz to 100kHz	10.9MΩ	3 to 5V	
60V	0 to 60.00V	6.00 to 60.00V	0.01V		0.8% L + 0.18% x [F(kHz)-1]L ±3 D		at 150Hz 1.8% L typ.	10.082MΩ	3 to 50V
600V	0 to 600.0V	60.0 to 600.0V	0.1V		at 300Hz 30% L typ.		10.008MΩ	3 to 500V	
1000V <sup>2)</sup>	0 to 1000V	60 to 1000V	1V						10.008MΩ

1) See the typical curve of the 300Hz filter on p. 29.

2) The LCD indicates "+OL" above +1050V, "-OL" below -1050V or above 1050VRMS.

3) From 1kHz, the measurement must exceed 15% of the range

Secondary measurements and displays: FREQ (AC coupling), MAX, MIN, PEAK

## Technical characteristics of the MX 5006 (continued)

### CURRENTS

#### DC current

Particular reference conditions:

µA range: Measuring a strong current for a long time can cause a temperature rise in some components. In this case, it is necessary to wait some time for the metrological characteristics specified in µA to be restored.

#### ADC

Range	Operating range	Specified measurement range	Resolution	Uncertainty (±)	Voltage drop	Protection
6000µA	0 to 6000µA	2 to 6000µA	1µA	0.8% L ± 5 D	25mV/mA	11A/1000V fuse >20kA
60mA	0 to 60.00mA	0.02 to 60.00mA	0.01mA	0.8% L ± 2 D	3mV/mA	
600mA	0 to 600.0mA	0.2 to 600.0mA	0.1mA	0.8% L ± 2 D	0.58mV/mA	
6A	0 to 6.000A	0.200 to 6.000A	0.001A	0.8% L ± 3 D	0.05V/A	
10A / 20A*	0 to 20.00A	0.20 to 20.00A	0.01A	0.8% L ± 2 D	0.05V/A	

The display indicates "OL" above 19.99A. The  symbol blinks and a beep sounds above 10A.

(\*) Acceptable overload: 10A to 20A for 30s max. with a pause of 5min between 2 measurements. Ambient temp. 35°C max.

#### AC current

#### Aac RMS

Range	Operating range	Specified measurement range	Resolution	Uncertainty (±) 40Hz to 20kHz (**)	Peak factor	Voltage drop	Protection
6000µA	0 to 6000µA	60 to 6000µA	1µA	1.2% L ± 5 D	2.6 to 5mA	25mV /mA	Fuse 11A/1000V > 20 kA
60mA	0 to 60.00mA	6.00 to 60.00mA	0.01mA	1% L ± 3 D	2.6 to 50mA	3mV /mA	
600mA	0 to 600.0mA	60.0 to 60.0mA	0.1mA		2.6 to 500mA	0.58mV /mA	
6 A	0 to 6.000 A	0.600 to 6.000 A	0.001 A	1.2% L ± 5 D	2.8 to 5 A	0.05V /mA	
10 A / 20 A*	0 to 20.00 A	1.00 to 10.00 A	0.01 A	1% L ± 3 D	3.7 to 8 A	0.05V /mA	

The display indicates "OL" above 19.99A. The  symbol blinks and a beep sounds above 10A.

Secondary measurements and displays: FREQ (AC coupling) MAX, MIN, PEAK

(\*) Acceptable overload: 10A to 20A for 30s max. with a pause of 5min between 2 measurements. Ambient temp. 35°C max.

(\*\*) Additional uncertainty with the 300Hz filter: see curve on p.29.

## Technical characteristics of the MX 5006 (continued)

**AC and DC current** **Warning:** the sum AC+DC must never exceed the range, 600mA, or 60mA, or 6000µA, or 6A, or 10A, as the case may be.

The AC component must represent at least 5% of the amplitude of the AC+DC total for it to be possible to measure it.

### AAC+DC TRMS

Range	Operating range	Specified measurement range	Resolution	Uncertainty AC 40Hz à 20kHz (±) (**)	Additional uncertainty DC (±)	Peak factor	Voltage drop	Protection
6000µA	0 to 6000µA	60 to 6000µA	1µA	1.2% L + 0.08% x [F(kHz)-1]L ±5 D	±15 D	2.6 to 5mA	25mV/mA	Fuse 11A/1000V > 20kA
60mA	0 to 60.00mA	6.00 to 60.00mA	0.01mA	1% L + 0.08% x [F(kHz)-1]L ±3 D	±13 D	2.6 to 50mA	3mV/mA	
600mA	0 to 600.0mA	60.0 to 60.0mA	0.1mA			2.6 to 500mA	0.58mV/mA	
6A	0 to 6.000A	0.600A to 6.000A	0.001A	1.2% L + 0.08% x [F(kHz)-1]L ±5 D	±10 D	2.8 to 5A	0.05V/mA	
10A /20A*	0 to 20.00A	0.60A to 20.00A	0.01A	1% L + 0.08% x [F(kHz)-1]L ±3 D	±10 D	3.7 to 8A	0.05V/mA	

The display indicates “OL” above 19.99A. The  symbol blinks and a beep sounds above 10A.

Secondary measurements and displays: FREQ (AC coupling) MAX, MIN, PEAK  
 (\*) Acceptable overload: 10A to 20A for 30s max. with a pause of 5min between 2 measurements. Ambient temp. 35°C max.

(\*\*) Additional uncertainty with the 300Hz filter: see curve on p.29.

### Frequency

Protection: 1414Vpk

Particular reference conditions: 150mV<U<600V

When the switch is set to Hz, the 300Hz filter is not in service.

### Switch set to "Hz", measurement of the frequency of a voltage

Range	Operating range	Specified measurement range	Resolution	Intrinsic error
60Hz	10.00 to 60.00Hz	10.00 to 60.00Hz	0.01Hz	0.1% L ±1 D
600Hz	10.0 to 600.0Hz	10.0 to 600.0Hz	0.1Hz	
6kHz	0 to 6.000kHz	0.010 to 6.000kHz	0.001kHz	
60kHz	0 to 60.00kHz	0.01 to 60.00kHz	0.01kHz	

Below 10Hz, or if the signal detection level is inadequate, the reading is forced to 0.

 **Measurement of the period in ms can be accessed using the  key.**

### Frequency voltage or frequency current simultaneously, (secondary display)

Particular reference conditions: 150mV < U < 600V

0.15A < I < 10A

Max. frequency measurable in volts: 60kHz

Max. frequency measurable in amperes: 60kHz

When the switch is set to VLowZ, Volts or Ampere, if the 300Hz filter is activated, the measurable frequency remains within the limits of the PB of the filter.

Below 10Hz, or if the signal detection level is inadequate, the reading is forced to “----”.

## Technical characteristics of the MX 5006 (continued)

### Resistance

Protection: 1414Vpk

Particular reference conditions:

The (+COM) input must not have been overloaded following the accidental application of a voltage to the input terminals with the switch set to  $\Omega$  or T°.

If this happens, the return to normal may take about ten minutes.

Range	Specified measurement range	Resolution	Uncertainty	Measurement current	Open-circuit voltage
600 $\Omega$	0 to 600.0 $\Omega$ *	0.1 $\Omega$	0.4% L $\pm$ 2 D	$\approx$ 1mA	< 5V
6k $\Omega$	0 to 6.000k $\Omega$	0.001k $\Omega$	0.4% L $\pm$ 2 D	$\approx$ 126.6 $\mu$ A	
60k $\Omega$	0 to 60.00k $\Omega$	0.01k $\Omega$		$\approx$ 12.6 $\mu$ A	
600k $\Omega$	0 to 600.0k $\Omega$	0.1k $\Omega$		$\approx$ 1.26 $\mu$ A	
6M $\Omega$	0 to 6.000M $\Omega$	0.001M $\Omega$	1.5% L $\pm$ 3 D	$\approx$ 240nA	
60 M $\Omega$	0 to 60.00M $\Omega$	0.01M $\Omega$	3% L $\pm$ 3 D	$\approx$ 29nA	

(\*) REL measurement

### Audible continuity

Protection: 1414Vpk. Response time <100ms

Range	Resolution	Uncertainty	Open-circuit voltage	Measurement current
600 $\Omega$	0.1 $\Omega$	Audible signal triggered < 30 $\Omega$ $\pm$ 5 $\Omega$	< 5V	< 1.1mA

### Diode Test

Protection: 1414Vpk

Range	Resolution	Uncertainty	Open-circuit voltage	Measurement current
3V	1mV	Audible signal triggered < 40mV $\pm$ 10mV	< 5V	< 1.1mA

### Capacitance

Protection: 1414Vpk

Range	Operating range	Specified measurement range	Resolution	Intrinsic error	Measurement current	Measurement time
6nF	0.100 to 6.000nF	0.100 to 6.000nF	0.001nF	2% L $\pm$ 15 D	$\approx$ 1,26 $\mu$ A	$\approx$ 400ms
60nF	0 to 60.00nF	0 to 60.00nF	0.01nF	1% L $\pm$ 8 D	$\approx$ 1,26 $\mu$ A	$\approx$ 400ms
600nF	0 to 600.0nF	0 to 600.0nF	0.1nF	1% L $\pm$ 5 D	$\approx$ 1.26 $\mu$ A	$\approx$ 400ms
6 $\mu$ F	0 to 6.000 $\mu$ F	0 to 6.000 $\mu$ F	0.001 $\mu$ F	1% L $\pm$ 5 D	$\approx$ 12.6 $\mu$ A	$\approx$ 0.125 s/ $\mu$ F
60 $\mu$ F	0 to 60.00 $\mu$ F	0 to 60.00 $\mu$ F	0.01 $\mu$ F	1% L $\pm$ 5 D	$\approx$ 126.6 $\mu$ A	$\approx$ 0.125 s/ $\mu$ F
600 $\mu$ F	0 to 600.0 $\mu$ F	0 to 600.0 $\mu$ F	0.1 $\mu$ F	3% L $\pm$ 5 D	$\approx$ 1mA	$\approx$ 0.125 s/ $\mu$ F
6mF	0 to 6.000mF	0 to 6.000mF	1 $\mu$ F	4% L $\pm$ 5 D	$\approx$ 1mA	$\approx$ 17 s/mF
60mF	0 to 60.00mF	0 to 60.00mF	10 $\mu$ F	6% L $\pm$ 5 D	$\approx$ 1mA	$\approx$ 17 s/mF

The use of wires that are very short and shielded is strongly recommended.

## Technical characteristics of the MX 5006 (continued)

### Temperature

Protection: 1414Vpk

#### Particular reference conditions:

An internal temperature rise may have been caused by:

- measurement of a strong current for a long time,
- overload of the +COM input with the switch set to T° or Ω.

In this case, it is necessary to wait some time to recover the specified metrological characteristics.

The multimeter must be at the temperature of the room. If not, recovering the metrological characteristics may take up to 2h. Otherwise, there may be a temperature offset, because the cold junction temperature reference is a little off.

If there is any doubt, it is possible to check by measuring a known temperature (example: ambient temperature) with the thermocouple.

Range	Operating range	Specified measurement range	Resolution	Uncertainty (±)
low	-200.0 °C to 200.0°C	- 60.0°C to 200.0°C	0.1°C	0.5% L ±2°C
	-328.0°F to 392.0°F	-76.0°F to 392.0°F	0.1°F	0.5% L ±4°F
high	-200°C to 1200°C	-60°C to 1200°C	1°C	0.5% L ±2°C
	-328°F to 2192°F	-76°F to 2192°F	1°F	0.5% L ±4°F

The stated accuracy in temperature measurement does not take into account the accuracy of the K thermocouple.

There is no upper limit on the temperature display, other than the 6000 D of the display unit.

### PEAK+ PEAK-

Add 1%L + 30D to obtain the accuracy corresponding to the function and the range.

Fmax = 1kHz (1ms)

### MAX / MIN

Add 0.2%L + 2D to obtain the accuracy corresponding to the function and the range.



Acquisition time of the extrema: approximately 100ms.

### Operation of the audible beep

Beep reporting a valid key →high-pitched sound	4kHz, 100ms
Beep reporting an invalid key →low-pitched sound	1kHz, 100ms
Bursts of 3 beeps separated by 5-second gaps (beep beep beep - gap - beep beep beep) reporting an overshoot of the danger threshold (600V) →medium-pitched sound	2kHz, 100ms
2 successive beeps (beep beep) reporting recording of the MAX, MIN, PEAK: → medium-pitched sound	2kHz, 100ms
Current >10A	4kHz, 100ms

## Technical characteristics of the MX 5006 (continued)

### Variation in the nominal range of use

Quantity of influence	Range of influence	Quantity influenced	Influence	
			typical	MAX
Temperature	0°C... 18 28 ... 40°C	VDCmV	0.01% L ±0.2 D / 1°C	0.02% L ±0.25 D / 1°C
		VACmV, V <sub>Lowz</sub> mV	0.08% L ±0.2 D / 1°C	0.15% L ±0.25 D / 1°C
		VDC	0.01% L ±0.1 D / 1°C	0.05% L ±0.1 D / 1°C
		VAC, VAC+DC V <sub>Lowz</sub>		0.15% L ±0.1 D / 1°C
		ADC	0.05% L ±0.1 D / 1°C	0.1% L ±0.1 D / 1°C
		AAC and AAC+DC	0.08% L ±0.1 D / 1°C	0.12% L ±0.1 D / 1°C
			0.01% L ±0.1 D / 1°C	0.1% L / 1°C
		Ω	0.05% L / 1°C	0.1% L / 1°C
		60MΩ		0.3% L / 1°C
		nF, μF		0.2% L ±0.1 D / 1°C
		mF		0.6% L ±0.1 D / 1°C
		Hz		0.01% L / 1°C
		Temperature		
Stabilization time		≈ 90 min	2 h	
Humidity (without condensation)	10% ... 80% RH	V A  Ω (*) Hz	0	0
Frequency	1kHz ... 3kHz	VAC		4% L
	3kHz ... 10kHz			6% L

(\*) excluding the 60MΩ range

### Response of the filter

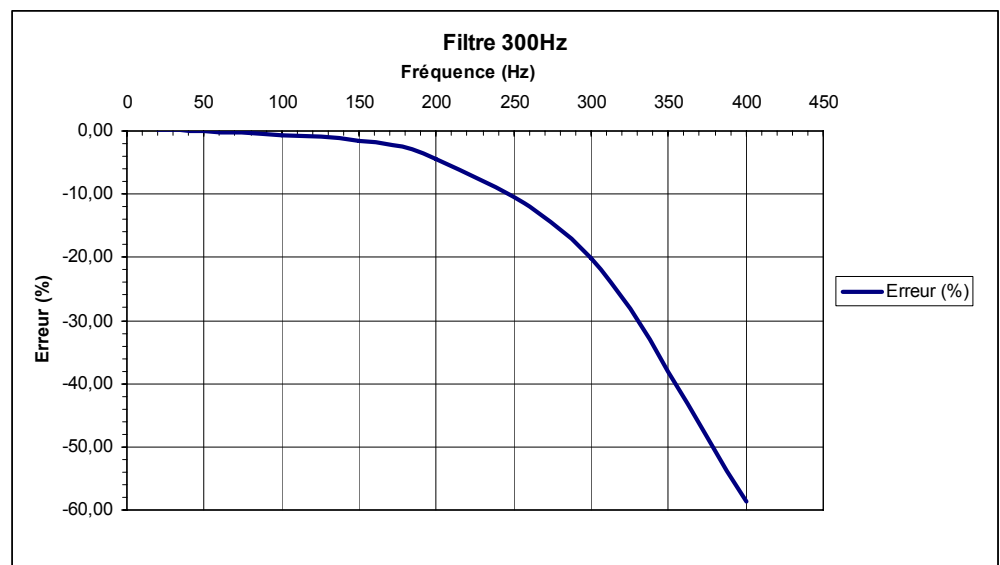

## Technical characteristics of the MX 5060

**Accuracy:** Only values with tolerances or limits are guaranteed values.  
 "n% + nD" means Values without tolerances are given for guidance (standard NFC42670).  
 "n% of the reading + n Digit" The technical specifications are guaranteed only after 30 minutes of warming up.  
 (cf. CEI 485) Except as otherwise indicated, they are valid from 5% to 100% of the measurement range.

### VOLTAGES

Protection: 1414Vpk

#### DC voltage

**V<sub>DC</sub>** 60mV range: Measuring a strong current or measuring a current for a long time may cause a temperature rise of some components.

Range	Specified measurement range	Resolution	Intrinsic error
60mV <sup>1)</sup>	0 to 60.000mV	0.001mV	0.5% L + 35 D
600mV	0 to 600.00mV	0.01mV	0.5% L + 25 D
6V	0 to 6.0000V	0.0001V	0.05% L + 25 D
60V	0 to 60.000V	0.001V	
600V	0 to 600.00V	0.01V	
1000V <sup>2)</sup>	0 to 1000.0V	0.1V	0.07% L + 25 D

1) This range is accessible only with the **RANGE** key.

Input impedance: approx. 10.6MΩ // 50pF

2) The display indicates "+OL" above +1050V and "-OL" below -1050V.

#### AC voltage

**V<sub>LowZ AC RMS</sub>** The PB is reduced to 300Hz. In V<sub>LowZ</sub>, there is no 60mV range. The frequency measurement is made like a measurement in a 300Hz bandwidth.

Range	Operating range	Specified measurement range <sup>3)</sup>	Resolution	Uncertainty (±)	Additional uncertainty F (Hz) <sup>1)</sup>	Input impedance // < 50 pF	Peak factor
600mV	0 to 600.00mV	60.00 to 600.00mV	0.01mV	1% L + 0.25% x [F(kHz)-1] L ± 30 D	45<F<65Hz 0.3% L typ.	≅ 520kΩ	3 to 500.0mV
6V	0 to 6.0000V	0.6 to 6.0000V	0.0001V	0.5% L + 0.18% x [F(kHz)-1] L ± 25 D	at 100Hz 0.7% L typ.		3 to 5.0V
60V	0 to 60.000V	6.000 to 60.000V	0.001V		at 150Hz 1.8% L typ.		3 to 50.0V
600V	0 to 600.00V	60.00 to 600.00V	0.01V		at 300Hz 30% L typ.		3 to 500.0V
1000V <sup>2)</sup>	0 to 1000.0V	60 to 1000.0V	0.1V				1.42 to 1000.0V

1) See the typical curve of the 300Hz filter on p. 37.

2) The LCD indicates "+OL" above +1050V, "-OL" below -1050V or above 1050VRMS.

3) From 1kHz, the measurement must exceed 15% of the range

Secondary measurements and displays: FREQ (AC coupling) MAX, MIN, PEAK

## Technical characteristics of the MX 5060 (continued)

**V<sub>AC</sub> RMS** 60mV range: Measuring a strong current or measuring a current for a long time may cause a temperature rise of some components.

Range	Operating range	Specified measurement range <sup>4)</sup>	Resolution	Uncertainty (±)	Additional uncertainty F(Hz) <sup>1)</sup>	Pass band	@ 1kHz Input impedance // < 50 pF	Peak factor
60mV <sup>2)</sup>	0 to 60.000mV	6.000 to 60.000mV	0.001mV	1.5% L ± 35 D	45<F<65Hz 0.3% L typ. à 100Hz 0.7% L typ. à 150Hz 1.8% L typ. à 300Hz 30% L typ.	≈ 400Hz	10.612MΩ	3 to 50.0mV
600mV	0 to 600.00mV	60.00 to 600.00mV	0.01mV	1% L + 0.25% x [F(kHz)-1] L ± 30 D		10Hz to 50kHz (≈ 23% @100kHz)	10.9MΩ	3 to 500.0mV
6V	0 to 6.0000V	0.6 to 6.0000V	0.0001V	0.5% L + 0.18% x [F(kHz)-1] L ± 25 D		10.9MΩ	3 to 5.0V	
60V	0 to 60.000V	6.000 to 60.000V	0.001V			10.082MΩ	3 to 50.0V	
600V	0 to 600.00V	60.00 to 600.00V	0.01V			10.008MΩ	3 to 500.0V	
1000V <sup>3)</sup>	0 to 1000.0V	60 to 1000.0V	0.1V			10.008MΩ	1.42 to 1000.0V	

1) See the typical curve of the 300Hz filter on p. 37.

2) This range is accessible only with the **RANGE** key.

Input impedance: approx. 10.6MΩ // 50pF

3) The LCD indicates “+OL” above +1050V, “-OL” below -1050V or above 1050VRMS.

4) From 1kHz, the measurement must exceed 15% of the range.

Secondary measurements and displays: FREQ (AC coupling) MAX, MIN, PEAK

### AC and DC voltage AC+DC TRMS

60mV range: Measuring a strong current or measuring a current for a long time may cause a temperature rise of some components.

Range	Operating range	Specified measurement range <sup>4)</sup>	Resolution	Additional uncertainty DC (±)	Uncertainty AC (±)	Additional uncertainty F(Hz) <sup>1)</sup>	Bandwidth	Input impedance // < 50 pF	Peak factor
60mV <sup>2)</sup>	0 to 60.000mV	6.000 to 60.000mV	0,001mV	± 15 D	1,5% L ±35 D	45<F<65Hz 0,3% L typ.	≈ 400Hz	10,612MΩ	3 to 50mV
600mV	0 to 600,00mV	60,00 to 600,00mV	0,01mV		0,8% L + 0,18% x [F(kHz)-1]L ±30 D		10Hz to 50kHz	10,9MΩ	3 to 500mV
6V	0 to 6,0000V	0,6 to 6,0000V	0,0001V		at 100Hz 0,7% L typ.	10,9MΩ	3 to 5V		
60V	0 to 60,000V	6,000 to 60,000V	0,001V		at 150Hz 1,8% L typ.	10,082MΩ	3 to 50V		
600V	0 to 600,00V	60,00 to 600,00V	0,01V		at 300Hz 30% L typ.	10,008MΩ	3 to 500V		
1000V <sup>3)</sup>	0 to 1000,0V	60 to 1000,0V	0,1V		10,008MΩ	1,42 to 1000V			

1) See the typical curve of the 300Hz filter on p. 37.

2) This range is accessible only with the **RANGE** key.

Input impedance: approx. 10.6MΩ // 50pF

3) The LCD indicates “+OL” above +1050V, “-OL” below -1050V or above 1050VRMS.

4) From 1kHz, the measurement must exceed 15% of the range

Secondary measurements and displays: FREQ (AC coupling) MAX, MIN, PEAK

## Technical characteristics of the MX 5060 (continued)

### CURRENTS

#### DC current

Particular reference conditions:

µA range: Measuring a strong current for a long time may cause a temperature rise of some components. In this case, it is necessary to wait some time for the metrological characteristics specified in µA to be restored.

**ADC**

Range	Operating range	Specified measurement range	Resolution	Uncertainty (±)	Voltage drop	Protection
6000µA	0 to 6000.0µA	2.0 to 6000.0µA	0.1µA	0.8% L ±25 D	25mV/mA	Fuse 11A/1000V > 20kA
60mA	0 to 60.000mA	0.020 to 60.000mA	0.001mA	0.8% L ±20 D	3mV/mA	
600mA	0 to 600.00mA	0.20 to 600.00mA	0.01mA	0.8% L ±20 D	0.58mV/mA	
6A	0 to 6.0000 A	0.2000 to 6.0000A	0.0001A	0.8% L ±20 D	0.05 V/A	
10A / 20A*	0 to 20.000A	0.200 to 20.000A	0.001A	0.8% L ±20 D	0.05 V/A	

The display indicates “OL” above 19.99A. The  symbol blinks and a beep sounds above 10A.

(\*) Acceptable overload: 10A to 20A for 30s max. with a pause of 5min between 2 measurements. Ambient temp. 35°C max.

#### AC current

**AC RMS**

Range	Operating range	Specified measurement range	Resolution	Uncertainty (±) 40Hz to 20kHz (**)	Peak factor	Voltage drop	Protection
6000µA	0 to 6000.0µA	60 to 6000.0µA	0.1µA	1.2% L + 0.08% x [F(kHz)-1]L ±25 D	2.6 to 5mA	25mV/mA	Fuse 11A/1000V > 20 kA
60mA	0 to 60.000mA	6.000 to 60.000mA	0.001mA	1% L + 0.08% x [F(kHz)-1]L ±25 D	2.6 to 50mA	3mV/mA	
600mA	0 to 600.00mA	60.00 to 600.00mA	0.01mA		2.6 to 500mA	0.58mV/mA	
6A	0 to 6.0000A	0.6000 to 6.000A	0.0001A	1% L + 0.1% x [F(kHz)-1]L ±25 D	2.8 to 5A	0.05V/mA	
10A /20A*	0 to 20.000A	1.000 to 20.000A	0.001A	1.2% L + 0.1% x [F(kHz)-1]L ±25 D	3.7 to 8A	0.05V/mA	

The display indicates “OL” above 19.99A. The  symbol blinks and a beep sounds above 10A.

Secondary measurements and displays: FREQ (AC coupling) MAX, MIN, PEAK

(\*) Acceptable overload: 10A to 20A for 30s max. with a pause of 5min between 2 measurements. Ambient temp. 35°C max.

(\*\*) Additional uncertainty with the 300Hz filter: see curve on p.37.

## Technical characteristics of the MX 5060 (continued)

### AC and DC current

**AC+DC TRMS Warning:** the sum AC+DC must never exceed the range, 600mA, or 60mA, or 6000 $\mu$ A, or 6A, or 10A, as the case may be.

The AC component must represent at least 5% of the amplitude of the AC+DC total for it to be possible to measure it.

Range	Operating range	Specified measurement range	Resolution	Uncertainty AC 40Hz - 20kHz ( $\pm$ ) (**)	Additional uncertainty DC ( $\pm$ )	Peak factor	Voltage drop	Protection
6000 $\mu$ A	0 to 6000.0 $\mu$ A	60 to 6000.0 $\mu$ A	0.1 $\mu$ A	1% L + 0.08% x [F(kHz)-1]L $\pm$ 25 D	$\pm$ 15 D	2.6 to 5mA	25mV/mA	Fuse 11A/1000V > 20kA
60mA	0 to 60.00mA	6.000 to 60.000mA	0.001mA	1% L + 0.08% x [F(kHz)-1]L $\pm$ 25 D		2.6 to 50mA	3mV/mA	
600mA	0 to 600.00mA	60.00 to 600.00mA	0.01mA	1% L + 0.1% x [F(kHz)-1]L $\pm$ 25 D		2.6 to 500mA	0.58mV/mA	
6A	0 to 6.0000A	0.6000 to 6.0000A	0.0001A	1.2% L + 0.1% x [F(kHz)-1]L $\pm$ 25 D		2.8 to 5A	0.05V/mA	
10A / 20A*	0 to 20.00A	0.600 to 20.000A	0.001A	1.2% L + 0.1% x [F(kHz)-1]L $\pm$ 25 D		3.7 to 8A	0.05V/mA	

The display indicates "OL" above 19.99A. The  symbol blinks and a beep sounds above 10A.

Secondary measurements and displays: FREQ (AC coupling) MAX, MIN, PEAK

(\*) Acceptable overload: 10A to 20A for 30s max. with a pause of 5min between 2 measurements. Ambient temp. 35°C max.

(\*\*) Additional uncertainty with the 300Hz filter: see curve on p.37.

## Technical characteristics of the MX 5060 (continued)

### Frequency

Protection: 1414Vpk

**Switch set to "Hz",  
measurement of the  
frequency  
of a voltage**

Particular reference conditions: 150mV<U<600V

When the switch is set to Hz, the 300Hz filter is not in service.

Range	Operating range	Specified measurement range	Resolution	Intrinsic error
60Hz	10.00 to 60.00Hz	10.00 to 60.00Hz	0.01Hz	0.1% L ±1 D
600Hz	10.0 to 600.0Hz	10.00 to 600.0Hz	0.1Hz	
6kHz	0 to 6.000kHz	0.010 to 6.000kHz	0.001kHz	
60kHz	0 to 60.00kHz	0.01 to 60.00kHz	0.01kHz	

Below 10Hz, or if the signal detection level is inadequate, the reading is forced to 0.

👉 **Measurement of the period in ms can be accessed using the **

**Freq. voltage  
or Freq. current  
simultaneously,  
(secondary display)**

Particular reference conditions:

150mV < U < 600V

0.15A < I < 10A

Max. frequency measurable in volts: 60kHz

Max. frequency measurable in amperes: 60kHz

When the switch is set to VLowZ, Volts or Ampere, if the 300Hz filter is activated, the measurable frequency remains within the limits of the PB of the filter.

Below 10Hz, or if the signal detection level is inadequate, the reading is forced: "-----".

### Resistance

Protection: 1414Vpk

Particular reference conditions:

The (+COM) input must not have been overloaded following the accidental application of a voltage to the input terminals with the switch set to Ω or T°.

If this happens, the return to normal may take about ten minutes.

Range	Specified measurement range	Resolution	Uncertainty	Measurement current	Open-circuit voltage
600Ω	0 to 600.00Ω *	0.01Ω	0.2% L ±20 D	≈ 1mA	< 5V
6kΩ	0 to 6.000kΩ	0.0001kΩ	0.2% L ±20 D	≈ 126.6μA	
60kΩ	0 to 60.000kΩ	0.001kΩ		≈ 12.6μA	
600kΩ	0 to 600.00kΩ	0.01kΩ		≈ 1.26μA	
6MΩ	0 to 6.0000MΩ	0.0001MΩ	1.5% L ±30 D	≈ 240nA	
60MΩ	0 to 60.000MΩ	0.001MΩ	3% L ±30 D	≈ 29nA	

(\*) REL measurement

## Technical characteristics of the MX 5060 (continued)

### Audible continuity

Protection: 1414Vpk  
Response time <100ms

Range	Resolution	Uncertainty	Open-circuit voltage	Measurement current
600Ω	0.01Ω	Audible signal triggered < 30Ω ±5Ω	< 5V	< 1.1mA

### Diode Test

Protection: 1414Vpk

Range	Resolution	Uncertainty	Open-circuit voltage	Measurement current
3V	0.1mV	Audible signal triggered < 40mV ±10mV	< 5V	< 1.1mA

### Capacitance

Protection: 1414Vpk

Range	Operating range	Specified measurement range	Resolution	Intrinsic error	Measurement current	Measurement time
6nF	0.100 to 6.000nF	0.100 to 6.000nF	0.001nF	2% L ±15 D	≈ 1,26μA	≈ 400ms
60nF	0 to 60.00nF	0 to 60.00nF	0.01nF	1% L ±8 D	≈ 1,26μA	≈ 400ms
600nF	0 to 600.0nF	0 to 600.0nF	0.1nF	1% L ±5 D	≈ 1.26μA	≈ 400ms
6μF	0 to 6.000μF	0 to 6.000μF	0.001μF	1% L ±5 D	≈ 12.6μA	≈ 0.125 s/μF
60μF	0 to 60.00μF	0 to 60.00μF	0.01μF	1% L ±5 D	≈ 126.6μA	≈ 0.125 s/μF
600μF	0 to 600.0μF	0 to 600.0μF	0.1μF	3% L ±5 D	≈ 1mA	≈ 0.125 s/μF
6mF	0 to 6.000mF	0 to 6.000mF	1μF	4% L ±5 D	≈ 1mA	≈ 17 s/mF
60mF	0 to 60.00mF	0 to 60.00mF	10μF	6% L ±5 D	≈ 1mA	≈ 17 s/mF

The use of wires that are very short and shielded is strongly recommended.

### Temperature

Protection: 1414Vpk

#### Particular reference conditions:

An internal temperature rise may have been caused by:

- measurement of a strong current for a long time,
- overload of the +COM input with the switch set to T° or Ω.

In this case, it is necessary to wait some time to recover the specified metrological characteristics.

The multimeter must be at the temperature of the room. If not, recovering the metrological characteristics may take up to 2h. Otherwise, there may be a temperature offset, because the cold junction temperature reference is a little off.

If there is any doubt, it is possible to check by measuring a known temperature (example: ambient temperature) with the thermocouple.

## Technical characteristics of the MX 5060 (continued)

### Temperature (continued)

Range	Operating range	Specified measurement range	Resolution	Uncertainty ( $\pm$ )
low	-200.0°C to 200.0°C	-60.0°C to 200.0°C	0.1°C	0.5% L $\pm$ 2°C
	-328.0°F to 392.0°F	-76.0°F to 392.0°F	0.1°F	0.5% L $\pm$ 4°F
high	-200°C to 1200°C	-60°C to 1200°C	1°C	0.5% L $\pm$ 2°C
	-328°F to 2192°F	-76°F to 2192°F	1°F	0.5% L $\pm$ 4°F

The stated accuracy in temperature measurement does not take into account the accuracy of the K thermocouple.

There is no upper limit on the temperature display, other than the 6000 D of the display unit.

### PEAK+ PEAK-

Add 1% L + 30 D to obtain the accuracy corresponding to the function and the range.

Fmax = 1kHz (1ms)

### MAX / MIN

Add 0.2% L + 2 D to obtain the accuracy corresponding to the function and the range.



Acquisition time of the extrema: approximately 100ms.

### Operation of the audible beep

Beep reporting a valid key →high-pitched sound	4kHz, 100ms
Beep reporting an invalid key →low-pitched sound	1kHz, 100ms
bursts of 3 beeps separated by 5-second gaps (beep beep beep - gap - beep beep beep) reporting an overshoot of the danger threshold (600V) →medium-pitched sound	2kHz, 100ms
2 successive beeps (beep beep) reporting recording of the MAX, MIN, PEAK: → medium-pitched sound	2kHz, 100ms
Current >10A	4kHz, 100ms

## Technical characteristics of the MX 5060 (continued)

### Variation in the nominal range of use

Quantity of influence	Range of influence	Quantity influenced	Influence	
			typical	MAX
Temperature	0°C ... 18 28 ... 40°C	VDCmV	0.01% L ±0.2 D / 1°C	0.02% L ±0.25 D / 1°C
		VACmV, V <sub>LowZ</sub> mV	0.08% L ±0.2 D / 1°C	0.15% L ±0.25 D / 1°C
		VDC	0.01% L ±0.1 D / 1°C	0.05% L ±0.1 D / 1°C
		VAC, VAC+DC, V <sub>LowZ</sub>		0.15% L ±0.1 D / 1°C
		ADC	0.05% L ±0.1 D / 1°C	0.1% L ±0.1 D / 1°C
		AAC and AAC+DC	0.08% L ±0.1 D / 1°C	0.12% L ±0.1 D / 1°C
			0.01% L ±0.1 D / 1°C	0.1% L / 1°C
		Ω	0.05% L / 1°C	0.1% L / 1°C
		60 MΩ		0.3% L / 1°C
		nF, μF		0.2% L ±0.1 D / 1°C
		mF		0.6% L ±0.1 D / 1°C
		Hz		0.01% L / 1°C
		Temperature		± 2°C + 0.05% L / 1°C
		Stabilization time		≈ 90 min
Humidity (without condensation)	10% ... 80% RH	V	0	0
		A		
				
		Ω (*)		
		Hz		
Frequency	1kHz ... 3kHz	VAC		4% L
	3kHz ... 10kHz			6% L

### Response of the filter

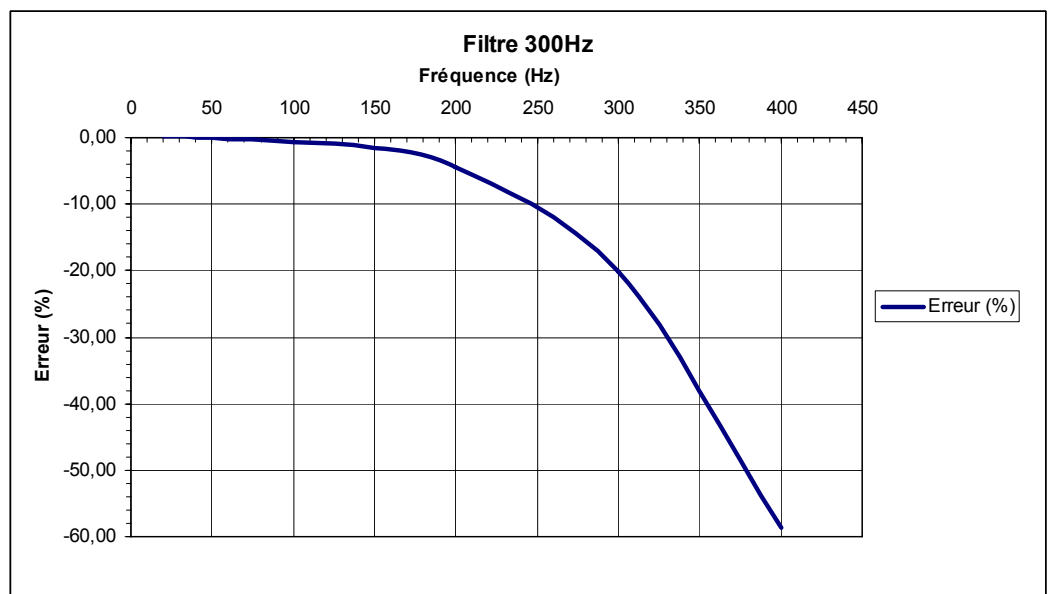

## General characteristics

### Environmental conditions

Altitude	<2000m
Reference range	23°C ±5°C
Specified range of use	0°C to 40°C
Influence of temperature	see §. Influences
Relative humidity	0% to 80% from 0°C to 35°C 0% to 70% from 35°C to 40°C limited to 70% for the 5 and 50 Ω ranges
Dust- and water-tightness	IP51
Storage range	-20°C to 70°C

### Power supply

Network	230V ±10% at 50Hz
Switchable	110V ±10% at 60Hz (US version)

### Display

The refresh rate of the display unit is 200ms.



### Safety

According to NF EN 61010-1:

- Insulation class 2
- Degree of pollution 2
- Use indoor
- Altitude <2000m
- Measurement category of the "measurements" inputs CAT III, 1000V with respect to earth
- Measurement category of the "measurements" inputs CAT IV, 600V with respect to earth

### EMC

This instrument is designed in conformity with the EMC standards in force and its compatibility has been tested in accordance with the following standards:

- Emissions (cl. A) and Immunity: NF EN 61326-1

## Mechanical characteristics

### Housing

• Dimensions	295 x 270 x 95 mm
• Mass	1.85 kg
• Materials	ABS V0
• Dust- and water-tightness	IP 51, according to NF EN 60529

## Supply

### supplied with the instrument

- Operating instructions in 5 languages on CD ROM
- Getting started guide
- EU line power cord
- Lead, 1.5m, straight/straight, red
- Lead, 1.5m, straight/straight, black
- Test probe, CAT IV, 1kV, red
- Test probe, CAT IV, 1kV, black

### *MX 5060*

- USB cord

### optional

- K thermocouple, wire + adapter
- SX-DMM BT software

### *spare*

- Fuse, 1000V 11A > 20kA 10 x 38mm (consult our regional Manumasure technical centre)