

High Speed Optocoupler, 1 MBd, Transistor Output

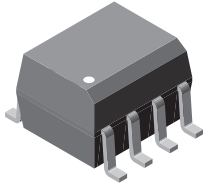

1179069

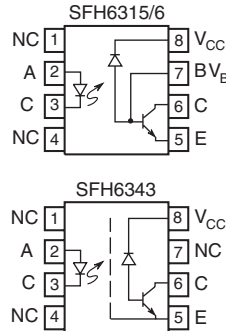

DESCRIPTION

The SFH6315T, SFH6316T, SFH6343T, high speed optocouplers, each consists of a GaAlAs infrared emitting diode, optically coupled with an integrated photo detector and a high speed transistor. The photo detector is junction isolated from the transistor to reduce miller capacitance effects. The open collector output function allows circuit designers to adjust the load conditions when interfacing with different logic systems such as TTL, CMOS, etc.

Because the SFH6343T has a faraday shield on the detector chip, it can also reject and minimize high input to output common mode transient voltages. There is no base connection, further reducing the potential electrical noise entering the package.

The SFH6315T, SFH6316T, SFH6343T are packaged in industry standard SOIC-8 packages and are suitable for surface mounting.

FEATURES

- Surface mountable
- Industry standard SOIC-8 footprint
- Compatible with infrared vapor phase reflow and wave soldering processes
- Isolation test voltage, 4000 V_{RMS}
- Very high common mode transient immunity: 15000 V/μs at V_{CM} = 1500 V guaranteed (SFH6343)
- High speed: 1 MBd
- TTL compatible
- Guaranteed AC and DC performance temperature: 0 °C to 70 °C
- Open collector output
- Pin compatible with agilent (HP) optocouplers
 - SFH6315T - HCPL0500
 - SFH6316T - HCPL0501
 - SFH6343T - HCPL0453
- Lead (Pb)-free component
- Component in accordance to RoHS 2002/95/EC and WEEE 2002/96/EC



RoHS
COMPLIANT

APPLICATIONS

- Line receivers
- Logic ground isolation
- Analog signal ground isolation
- Replace pulse transformers

AGENCY APPROVALS

- UL1577, file no. E52744 system code Y
- CUL - file no. E52744, equivalent to CSA bulletin 5A
- DIN EN 60747-5-5 (VDE 0884) available with option 1

ORDER INFORMATION	
PART	REMARKS
SFH6315T	CTR > 5.0 %, SOIC-8
SFH6316T	CTR > 15 %, SOIC-8
SFH6343T	CTR > 19 %, SOIC-8

Note

For additional information on the available options refer to option information.

ABSOLUTE MAXIMUM RATINGS (1)				
PARAMETER	TEST CONDITION	SYMBOL	VALUE	UNIT
INPUT				
Reverse voltage		V _R	3.0	V
DC forward current		I _F	25	mA
Surge forward current	t _p ≤ 1.0 μs, 300 pulses/s	I _{FSM}	1.0	A
Power dissipation	T _{amb} ≤ 70 °C	P _{diss}	45	mW
OUTPUT				
Supply voltage		V _S	- 0.5 to 30	V
Output voltage		V _O	- 0.5 to 25	V
Output current		I _O	8.0	mA
Power dissipation	T _{amb} ≤ 70 °C	P _{diss}	100	mW

SFH6315T, SFH6316T, SFH6343T

Vishay Semiconductors

High Speed Optocoupler, 1 MBd,
Transistor Output



ABSOLUTE MAXIMUM RATINGS ⁽¹⁾				
PARAMETER	TEST CONDITION	SYMBOL	VALUE	UNIT
COUPLER				
Isolation test voltage between emitter and detector		V_{ISO}	4000	V_{RMS}
Pollution degree (DIN VDE 0110)			2	
Creepage distance			≥ 4	mm
Clearance distance			≥ 4	mm
Comparative tracking index per DIN IEC 112/VDE 0303 part 1		CTI	175	
Isolation resistance	$V_{IO} = 500\text{ V}, T_{amb} = 25\text{ }^\circ\text{C}, R_{ISOL}^{(2)}$	R_{IO}	$\geq 10^{12}$	Ω
	$V_{IO} = 500\text{ V}, T_{amb} = 100\text{ }^\circ\text{C}, R_{ISOL}^{(2)}$	R_{IO}	$\geq 10^{11}$	Ω
Storage temperature range		T_{stg}	- 55 to + 150	$^\circ\text{C}$
Ambient temperature range		T_{amb}	- 55 to + 100	$^\circ\text{C}$
Junction temperature		T_j	100	$^\circ\text{C}$
Soldering temperature ⁽³⁾	max. 10 s, dip soldering distance to seating plane ≥ 1.5 mm		260	$^\circ\text{C}$

Notes

⁽¹⁾ $T_{amb} = 25\text{ }^\circ\text{C}$, unless otherwise specified.

Stresses in excess of the absolute maximum ratings can cause permanent damage to the device. Functional operation of the device is not implied at these or any other conditions in excess of those given in the operational sections of this document. Exposure to absolute maximum ratings for extended periods of the time can adversely affect reliability.

⁽²⁾ Device considered a two-terminal device: pins 1, 2, 3, and 4 shorted together and pins 5, 6, 7, and 8 shorted together.

⁽³⁾ Refer to reflow profile for soldering conditions for surface mounted devices.

ELECTRICAL CHARACTERISTICS ⁽¹⁾							
PARAMETER	TEST CONDITION	PART	SYMBOL	MIN.	TYP.	MAX.	UNIT
INPUT							
Forward voltage	$I_F = 16\text{ mA}, 25\text{ }^\circ\text{C}$		V_F		1.6	1.8	V
			V_F		1.6	1.9	V
Reverse current	$V_R = 3\text{ V}$		I_R		0.5	10	μA
Capacitance	$f = 1\text{ MHz}, V_F = 0\text{ V}$		C_{IN}		75		pF
Temperature coefficient of forward voltage	$I_F = 16\text{ mA}$		$\frac{\Delta V_F}{\Delta T_{amb}}$		- 1.7		mW/ $^\circ\text{C}$
OUTPUT							
Logic low supply current	$I_F = 16\text{ mA}, V_O = \text{open}, V_{CC} = 15\text{ V}$		I_{CCL}		200		μA
Logic high supply current	$I_F = 0\text{ mA}, V_O = \text{open}, V_{CC} = 15\text{ V}; 25\text{ }^\circ\text{C}$		I_{CCH}		0.001	1	μA
			I_{CCH}		0.001	2	μA
Logic low output voltage	$I_F = 16\text{ mA}, V_{CC} = 4.5\text{ V}, I_O = 1.1\text{ mA}, 25\text{ }^\circ\text{C}$	SFH6315T	V_{OL}		0.15	0.4	V
	$I_F = 16\text{ mA}, V_{CC} = 4.5\text{ V}, I_O = 0.8\text{ mA}$	SFH6315T	V_{OL}		0.15	0.5	V
	$I_F = 16\text{ mA}, V_{CC} = 4.5\text{ V}, I_O = 3\text{ mA}, 25\text{ }^\circ\text{C}$	SFH6316T	V_{OL}		0.15	0.4	V
	$I_F = 16\text{ mA}, V_{CC} = 4.5\text{ V}, I_O = 2.4\text{ mA}$	SFH6343T	V_{OL}		0.15	0.5	V
	$I_F = 16\text{ mA}, V_{CC} = 4.5\text{ V}, I_O = 2.4\text{ mA}$	SFH6316T	V_{OL}		0.15	0.5	V
	$I_F = 16\text{ mA}, V_{CC} = 4.5\text{ V}, I_O = 2.4\text{ mA}$	SFH6343T	V_{OL}		0.15	0.5	V
Logic high output current	$I_F = 0\text{ mA}, V_O = V_{CC} = 5.5\text{ V}, 25\text{ }^\circ\text{C}$		I_{OH}		0.003	0.5	μA
	$I_F = 0\text{ mA}, V_O = V_{CC} = 15\text{ V}, 25\text{ }^\circ\text{C}$		I_{OH}		0.01	1	μA
	$I_F = 0\text{ mA}, V_O = V_{CC} = 15\text{ V}$		I_{OH}			50	μA



SFH6315T, SFH6316T, SFH6343T

High Speed Optocoupler, 1 MBd, Transistor Output Vishay Semiconductors

ELECTRICAL CHARACTERISTICS (1)							
PARAMETER	TEST CONDITION	PART	SYMBOL	MIN.	TYP.	MAX.	UNIT
COUPLER							
Capacitance (input to output) (2)	f = 1 MHz		C _{IO}		0.4		pF

Notes

- (1) T_{amb} = 25 °C, unless otherwise specified.
Minimum and maximum values are testing requirements. Typical values are characteristics of the device and are the result of engineering evaluation. Typical values are for information only and are not part of the testing requirements.
- (2) A 0.1 μF bypass capacitor connected between pins 5 and 8 is recommended.

CURRENT TRANSFER RATIO							
PARAMETER	TEST CONDITION	PART	SYMBOL	MIN.	TYP.	MAX.	UNIT
Current transfer ratio	V _O = 0.4 V, I _F = 16 mA, V _{CC} = 4.5 V, 25 °C	SFH6315T	CTR	7	16	50	%
	V _O = 0.5 V, I _F = 16 mA, V _{CC} = 4.5 V	SFH6315T	CTR	5	17		%
	V _O = 0.4 V, I _F = 16 mA, V _{CC} = 4.5 V, 25 °C	SFH6316T	CTR	19	35	50	%
	V _O = 0.4 V, I _F = 16 mA, V _{CC} = 4.5 V, 25 °C	SFH6343T	CTR	19	35	50	%
	V _O = 0.5 V, I _F = 16 mA, V _{CC} = 4.5 V	SFH6343T	CTR	15	36		%
	V _O = 0.5 V, I _F = 16 mA, V _{CC} = 4.5 V	SFH6316T	CTR	15	36		%

Note

Current transfer ratio in percent equals the ratio of output collector current (I_O) to the forward LED input current (I_F) times 100. A 0.1 μF bypass capacitor connected between pins 5 and 8 is recommended.

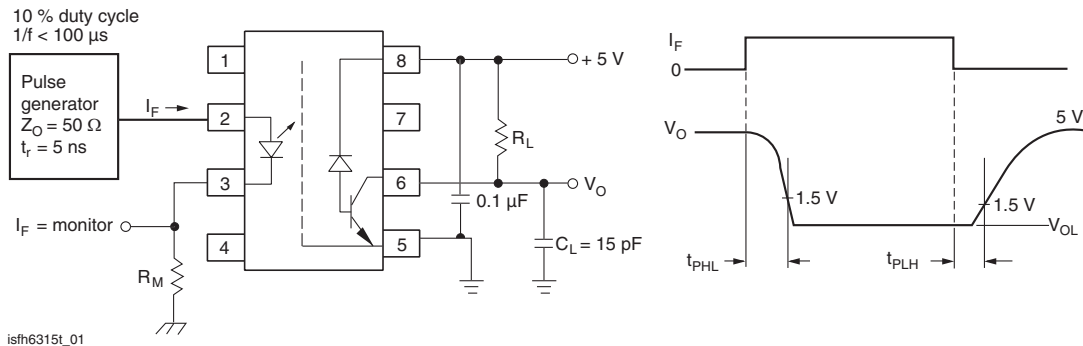

Fig. 1 - Test Circuit for Switching Times

SWITCHING CHARACTERISTICS (1)							
PARAMETER	TEST CONDITION	PART	SYMBOL	MIN.	TYP.	MAX.	UNIT
Propagation delay time to logic low at output (see fig. 1)	R _L = 4.1 KΩ	SFH6315T	t _{PHL} (2)		0.5	1.5	μs
		SFH6315T	t _{PHL}		0.5	2	μs
	R _L = 1.9 KΩ	SFH6316T	t _{PHL}		0.25	0.8	μs
		SFH6343T	t _{PHL}		0.25	1	μs
Propagation delay time to logic high at output (see fig. 1)	R _L = 4.1 KΩ	SFH6315T	t _{PLH} (2)		0.5	1.5	μs
		SFH6315T	t _{PLH}		0.5	2	μs
	R _L = 1.9 KΩ	SFH6316T	t _{PLH}		0.5	0.8	μs
		SFH6343T	t _{PLH}		0.5	1	μs

Notes

- (1) Over recommended temperature (T_{amb} = 0 °C to 70 °C), V_{CC} = 5.0 V, I_F = 16 mA unless otherwise specified.
The 1.9 kW load represents 1 TTL unit load of 1.6 mA and the 5.6 kW pull-up resistor.
The 4.1 kW load represents 1 LSTTL unit load of 0.36 mA and the 6.1 kW pull-up resistor.
- (2) T_{amb} = 25 °C, unless otherwise specified.

COMMON MODE TRANSIENT IMMUNITY							
PARAMETER	TEST CONDITION	PART	SYMBOL	MIN.	TYP.	MAX.	UNIT
Common mode transient immunity at logic high level output (see fig. 2)	$R_L = 4.1\text{ k}\Omega, I_F = 0\text{ mA}, V_{CM} = 10\text{ V}_{P-P}$	SFH6315T	$ CM_H $		1		kV/ μ s
	$R_L = 1.9\text{ k}\Omega, I_F = 0\text{ mA}, V_{CM} = 1500\text{ V}_{P-P}$	SFH6316T	$ CM_H $		1		kV/ μ s
		SFH6343T	$ CM_H $	15	30		kV/ μ s
Common mode transient immunity at logic low level output (see fig. 2)	$R_L = 4.1\text{ k}\Omega, I_F = 16\text{ mA}, V_{CM} = 10\text{ V}_{P-P}$	SFH6315T	$ CM_L $		1		kV/ μ s
	$R_L = 1.9\text{ k}\Omega, I_F = 16\text{ mA}, V_{CM} = 10\text{ V}_{P-P}$	SFH6316T	$ CM_L $		1		kV/ μ s
		SFH6343T	$ CM_L $	15	30		kV/ μ s

Note

Common mode transient immunity in a logic high level is the maximum tolerable (positive) dV_{CM}/dt on the leading edge of the common mode pulse (V_{CM}) to assure that the output will remain in a logic high state (i.e., $V_O > 2.0\text{ V}$). Common mode transient immunity in a logic low level the maximum tolerable (negative) dV_{CM}/dt on the trailing edge of the common mode pulse signal (V_{CM}) to assure that the output will remain in logic low state, i.e., $V_O > 0.8\text{ V}$.

The 1.9 k Ω load represents 1 TTL unit load of 1.6 mA and the 5.6 k Ω pull-up resistor.
The 4.1 k Ω load represents 1 LSTTL unit load of 0.36 mA and the 6.1 k Ω pull-up resistor.

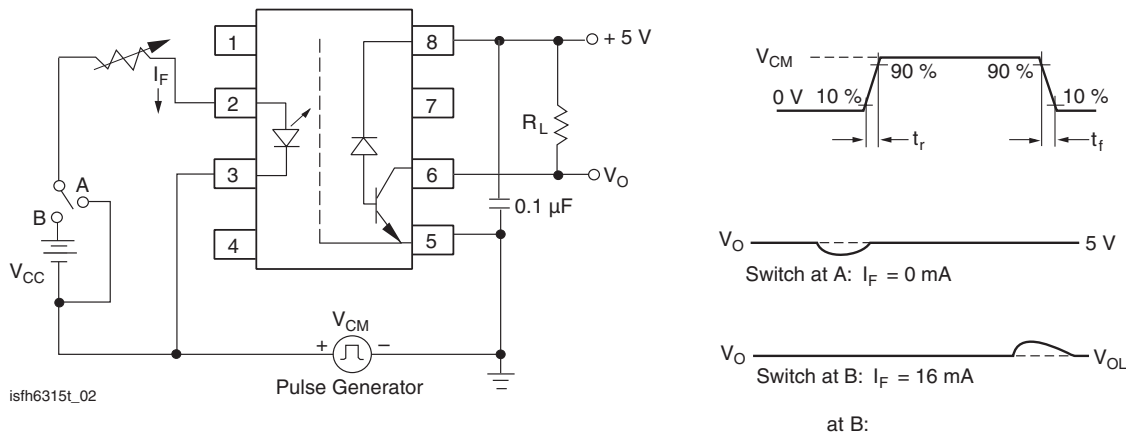

Fig. 2 - Test Circuit for Transient Immunity and Typical Waveforms

SAFETY AND INSULATION RATINGS							
PARAMETER	TEST CONDITION	SYMBOL	MIN.	TYP.	MAX.	UNIT	
Climatic Classification (according to IEC 68 part 1)				55/100/21			
Comparative Tracking Index		CTI	175		399		
V_{IOTM}			6000			V	
V_{IORM}			560			V	
P_{SO}					350	mW	
I_{SI}					150	mA	
T_{SI}					165	$^{\circ}$ C	
Creepage distance			4			mm	
Clearance distance			4			mm	
Insulation thickness			0.2			mm	

Note

As per IEC 60747-5-2, § 7.4.3.8.1, this optocoupler is suitable for "safe electrical insulation" only within the safety ratings. Compliance with the safety ratings shall be ensured by means of protective circuits.



SFH6315T, SFH6316T, SFH6343T

High Speed Optocoupler, 1 MBd, Transistor Output
Vishay Semiconductors

TYPICAL CHARACTERISTICS

$T_{amb} = 25\text{ }^{\circ}\text{C}$, unless otherwise specified

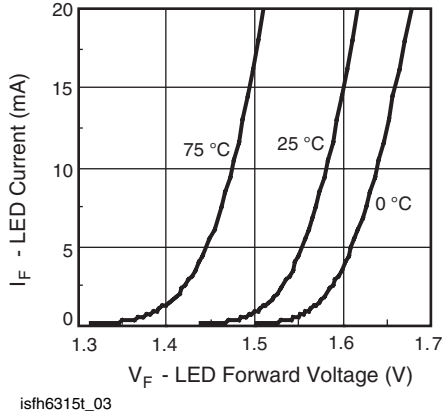

Fig. 3 - LED Forward Current vs. Forward Voltage

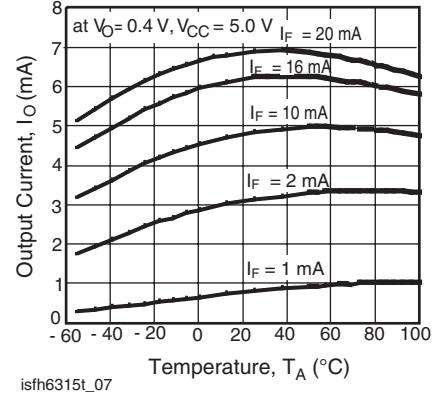

Fig. 6 - Output Current vs. Temperature

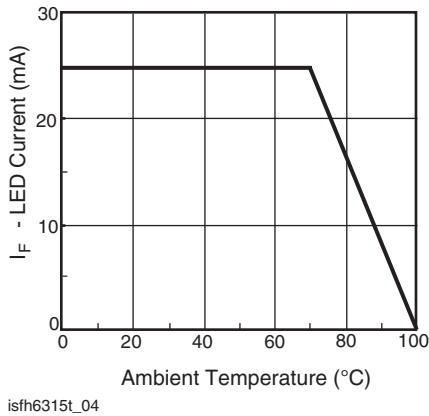

Fig. 4 - Permissible Forward LED Current vs. Temperature

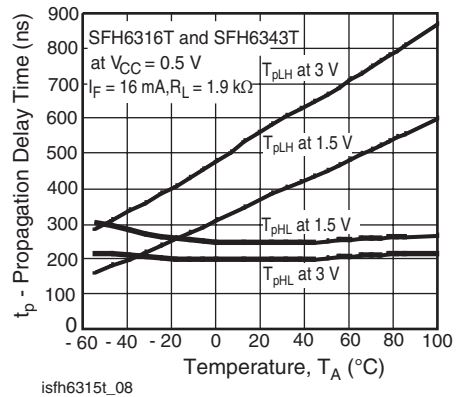

Fig. 7 - Propagation Delay vs. Temperature SFH6316T and SFH6343T

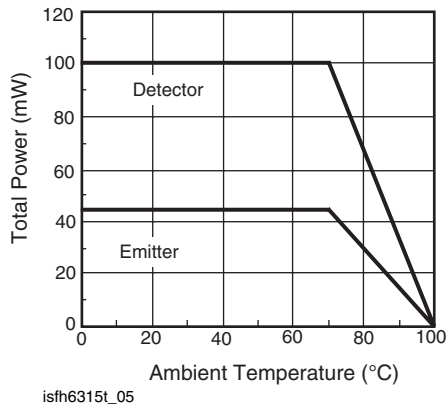

Fig. 5 - Permissible Power Dissipation vs. Temperature

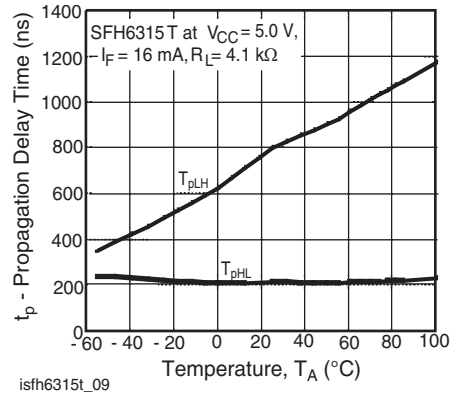

Fig. 8 - Propagation Delay vs. Temperature SFH6315T

SFH6315T, SFH6316T, SFH6343T



Vishay Semiconductors

High Speed Optocoupler, 1 MBd,
Transistor Output

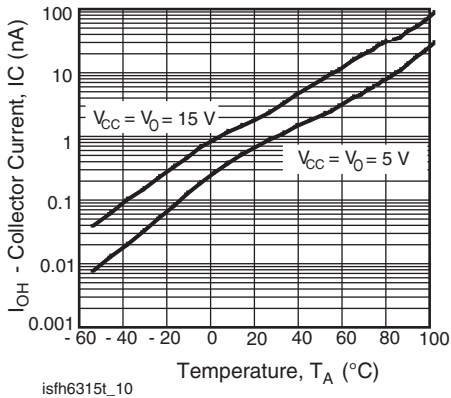

Fig. 9 - Logic High Output Current vs. Temperature

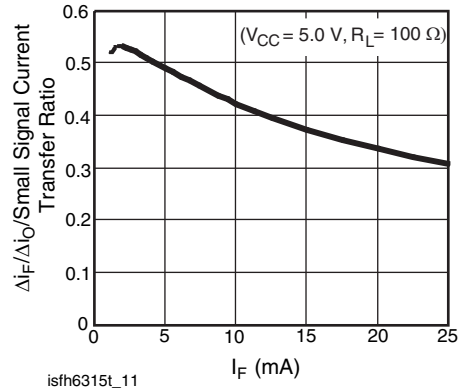
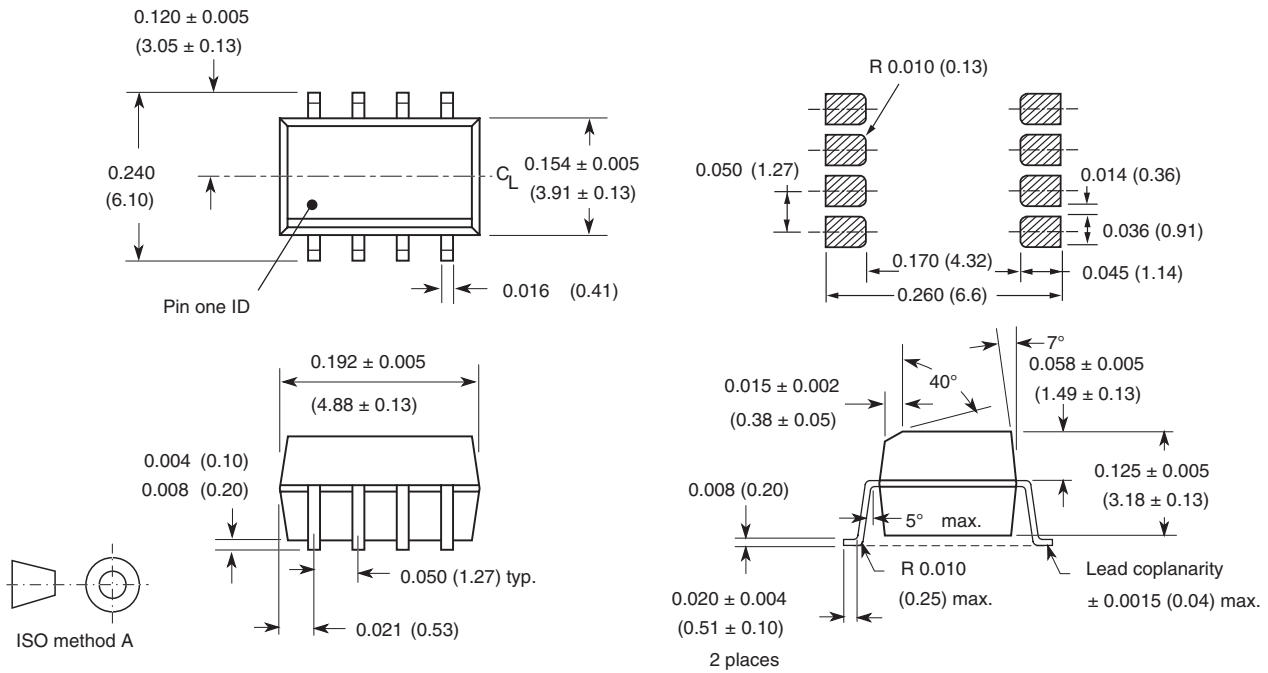

Fig. 10 - Small Signal Current Transfer Ratio vs. Input Current

PACKAGE DIMENSIONS in inches (millimeters)





OZONE DEPLETING SUBSTANCES POLICY STATEMENT

It is the policy of Vishay Semiconductor GmbH to

1. Meet all present and future national and international statutory requirements.
2. Regularly and continuously improve the performance of our products, processes, distribution and operating systems with respect to their impact on the health and safety of our employees and the public, as well as their impact on the environment.

It is particular concern to control or eliminate releases of those substances into the atmosphere which are known as ozone depleting substances (ODSs).

The Montreal Protocol (1987) and its London Amendments (1990) intend to severely restrict the use of ODSs and forbid their use within the next ten years. Various national and international initiatives are pressing for an earlier ban on these substances.

Vishay Semiconductor GmbH has been able to use its policy of continuous improvements to eliminate the use of ODSs listed in the following documents.

1. Annex A, B and list of transitional substances of the Montreal Protocol and the London Amendments respectively.
2. Class I and II ozone depleting substances in the Clean Air Act Amendments of 1990 by the Environmental Protection Agency (EPA) in the USA.
3. Council Decision 88/540/EEC and 91/690/EEC Annex A, B and C (transitional substances) respectively.

Vishay Semiconductor GmbH can certify that our semiconductors are not manufactured with ozone depleting substances and do not contain such substances.

We reserve the right to make changes to improve technical design
and may do so without further notice.

Parameters can vary in different applications. All operating parameters must be validated for each customer application by the customer. Should the buyer use Vishay Semiconductors products for any unintended or unauthorized application, the buyer shall indemnify Vishay Semiconductors against all claims, costs, damages, and expenses, arising out of, directly or indirectly, any claim of personal damage, injury or death associated with such unintended or unauthorized use.

Vishay Semiconductor GmbH, P.O.B. 3535, D-74025 Heilbronn, Germany



Disclaimer

All product specifications and data are subject to change without notice.

Vishay Intertechnology, Inc., its affiliates, agents, and employees, and all persons acting on its or their behalf (collectively, "Vishay"), disclaim any and all liability for any errors, inaccuracies or incompleteness contained herein or in any other disclosure relating to any product.

Vishay disclaims any and all liability arising out of the use or application of any product described herein or of any information provided herein to the maximum extent permitted by law. The product specifications do not expand or otherwise modify Vishay's terms and conditions of purchase, including but not limited to the warranty expressed therein, which apply to these products.

No license, express or implied, by estoppel or otherwise, to any intellectual property rights is granted by this document or by any conduct of Vishay.

The products shown herein are not designed for use in medical, life-saving, or life-sustaining applications unless otherwise expressly indicated. Customers using or selling Vishay products not expressly indicated for use in such applications do so entirely at their own risk and agree to fully indemnify Vishay for any damages arising or resulting from such use or sale. Please contact authorized Vishay personnel to obtain written terms and conditions regarding products designed for such applications.

Product names and markings noted herein may be trademarks of their respective owners.