

Surge protection device - PT-IQ-2X2-24DC-UT - 2800980

Please be informed that the data shown in this PDF Document is generated from our Online Catalog. Please find the complete data in the user's documentation. Our General Terms of Use for Downloads are valid (<http://download.phoenixcontact.com>)



Surge protection, consisting of protective plug and base element, with integrated multi-stage status indicator on the module for two 2-wire floating signal circuits.

Product Features

- ✓ Surge protection system
- ✓ Multi-level state monitoring
- ✓ Collective message about supply and remote module
- ✓ System supplied via DIN rail bus
- ✓ Up to 28 protection modules per supply module
- ✓ Maximum ease of maintenance thanks to the two-piece design
- ✓ Codable plug
- ✓ Impedance-neutral disconnection of plug for maintenance purposes
- ✓ Base element remains an integral part of the installation



Key commercial data

Packing unit	1 PCE
GTIN	 4 046356 665803
Custom tariff number	85363010
Country of origin	GERMANY

Technical data

General

Housing material	PA 6.6
Inflammability class according to UL 94	V0
Color	black
Ambient temperature (operation)	-40 °C ... 70 °C

Surge protection device - PT-IQ-2X2-24DC-UT - 2800980

Technical data

General

Ambient temperature (storage/transport)	-40 °C ... 85 °C
Mounting type	DIN rail mounting
Design	DIN rail module, two-section, divisible
Degree of protection	IP20
Direction of action	Line-Line & Line-Signal Ground/Shield & optional Signal Ground/Shield-Earth Ground
Width	17.7 mm
Height	91 mm
Depth	77.5 mm
Pitch unit	1 Div.

Protective circuit

IEC category	C1
IEC category	C2
IEC category	C3
IEC category	D1
Nominal voltage U_N	24 V
Maximum continuous operating voltage U_C	30 V DC
Maximum continuous operating voltage U_C	21 V AC
Nominal current I_N	700 mA (Up to 45°C)
Operating effective current I_C at U_C	≤ 1 mA (per system)
Ground conductor current I_{PE}	≤ 2 μ A (per system)
Nominal discharge surge current I_n (8/20) μ s (Core-Core)	10 kA
Nominal discharge surge current I_n (8/20) μ s (Core-Earth)	10 kA
Lightning test current (10/350) μ s, peak value I_{imp}	2.5 kA
Protection level U_p (Core-Core)	≤ 80 V (C1 - 1 kV/500 A)
Protection level U_p (Core-Core)	≤ 130 V (C2 - 10 kV / 5 kA)
Protection level U_p (Core-Core)	≤ 150 V (C2 - 10 kA)
Protection level U_p (Core-Core)	≤ 55 V (C3 - 25 A)
Protection level U_p (Core-Core)	≤ 60 V (C3 - 100 A)
Protection level U_p (Core-Earth)	≤ 600 V (C1 - 1 kV/500 A)
Protection level U_p (Core-Earth)	≤ 750 V (C2 - 10 kV / 5 kA)
Protection level U_p (Core-Earth)	≤ 800 V (C2 - 10 kA)
Protection level U_p (Core-Earth)	≤ 700 V (C3 - 25 A)
Protection level U_p (Core-Earth)	≤ 800 V (C3 - 100 A)
Protection level U_p static (core-core)	≤ 65 V (C1 - 1 kV/500 A)
Response time t_A (Core-Core)	≤ 1 ns

Surge protection device - PT-IQ-2X2-24DC-UT - 2800980

Technical data

Protective circuit

Response time t_A (Core-Earth)	≤ 100 ns
Input attenuation a_E , sym.	typ. 0.3 dB (≤ 270 kHz)
Cut-off frequency f_g (3 dB), sym. in 150 Ohm system	typ. 1.1 MHz
Capacity (Core-Earth)	2 nF
Resistance in series	1.2 Ω ± 5 %
Message: Surge protection fault	Optical, multi-stage
Max. required back-up fuse	0.8 A (FF)
Surge carrying capacity in acc. with IEC 61643-21 (Core-Core)	C1 (1 kV/500 A)
Surge carrying capacity in acc. with IEC 61643-21 (Core-Core)	C2 (10 kV/5 kA)
Surge carrying capacity in acc. with IEC 61643-21 (Core-Core)	C2 (10 kA)
Surge carrying capacity in acc. with IEC 61643-21 (Core-Core)	C3 (25 A)
Surge carrying capacity in acc. with IEC 61643-21 (Core-Core)	C3 (50 A)
Surge carrying capacity in acc. with IEC 61643-21 (Core-Core)	C3 (100 A)
Surge carrying capacity in acc. with IEC 61643-21 (Core-Earth)	C1 (1 kV / 500 A)
Surge carrying capacity in acc. with IEC 61643-21 (Core-Earth)	C2 (10 kV / 5 kA)
Surge carrying capacity in acc. with IEC 61643-21 (Core-Earth)	C2 (10 kA)
Surge carrying capacity in acc. with IEC 61643-21 (Core-Earth)	C3 (25 A)
Surge carrying capacity in acc. with IEC 61643-21 (Core-Earth)	C3 (50 A)
Surge carrying capacity in acc. with IEC 61643-21 (Core-Earth)	C3 (100 A)
Surge carrying capacity in acc. with IEC 61643-21 (Core-Earth)	D1 (2.5 kA)
Pulse reset time t_r in acc. with IEC 61643-21 (Core-Core)	≤ 4000 ms
Pulse reset time t_r in acc. with IEC 61643-21 (Core-Earth)	≤ 2600 ms
Overload failure mode as per IEC 61643-21 (plug)	Mode 2

Connection data

Connection method	Screw connection
Connection type IN	Screw terminal blocks
Connection type OUT	Screw terminal blocks
Tightening torque	0.5 Nm
Stripping length	8 mm
Conductor cross section solid min.	0.2 mm ²
Conductor cross section solid max.	4 mm ²
Conductor cross section AWG/kcmil min.	24
Conductor cross section AWG/kcmil max	12

Connection, equipotential bonding

Connection method	NS 35 DIN rail or connection terminal block
-------------------	---

Surge protection device - PT-IQ-2X2-24DC-UT - 2800980

Classifications

ETIM

ETIM 3.0	EC000943
ETIM 4.0	EC000943
ETIM 5.0	EC000943

UNSPSC

UNSPSC 11	39121610
UNSPSC 12.01	39121610
UNSPSC 13.2	39121620
UNSPSC 6.01	30212010
UNSPSC 7.0901	39121610

eCl@ss

eCl@ss 4.0	27140201
eCl@ss 4.1	27130801
eCl@ss 5.0	27130801
eCl@ss 5.1	27130801
eCl@ss 6.0	27130807
eCl@ss 7.0	27130807

Accessories

Accessories

Marking

Marker pen - X-PEN 0,35 - 0811228



Marker pen without ink cartridge, for manual labeling of markers, labeling extremely wipe-proof, line thickness 0.35 mm

Zack Marker strip, flat - ZBF 5:UNBEDRUCKT - 0808642



Zack Marker strip, flat, Strip, white, Unlabeled, Can be labeled with: Plotter, Mounting type: Snap into flat marker groove, For terminal block width: 5 mm, Lettering field: 5.1 x 5.2 mm

Surge protection device - PT-IQ-2X2-24DC-UT - 2800980

Accessories

Zack Marker strip, flat - ZBF 5/WH-100:UNBEDRUCKT - 0808668



Zack Marker strip, flat, Strip, white, Unlabeled, Can be labeled with: Plotter, Mounting type: Snap into flat marker groove, For terminal block width: 5 mm, Lettering field: 5.15 x 5.15 mm

Zack Marker strip, flat - ZBF 5,LGS:FORTL.ZAHLEN - 0808671



Zack Marker strip, flat, Strip, white, labeled, Printed horizontally: Consecutive numbers 1 - 10, 11 - 20, etc. up to 491 - 500, Mounting type: Snap into flat marker groove, For terminal block width: 5 mm, Lettering field: 5.15 x 5.15 mm

Zack Marker strip, flat - ZBF 5,LGS:GERADE ZAHLEN - 0810821



Zack Marker strip, flat, Strip, white, labeled, Printed horizontally: Consecutive numbers 2 - 20, 22 - 40, etc. up to 82 - 100, Mounting type: Snap into flat marker groove, For terminal block width: 5 mm, Lettering field: 5.15 x 5.15 mm

Zack Marker strip, flat - ZBF 5,LGS:UNGERADE ZAHLEN - 0810863



Zack Marker strip, flat, Strip, white, labeled, Printed horizontally: Odd numbers 1 - 19, 21 - 39, etc. up to 81 - 99, Mounting type: Snap into flat marker groove, For terminal block width: 5 mm, Lettering field: 5.15 x 5.15 mm

Zack Marker strip, flat - ZBF 5,QR:FORTL.ZAHLEN - 0808697



Zack Marker strip, flat, Strip, white, labeled, Printed vertically: Consecutive numbers 1 - 10, 11 - 20, etc. up to 91 - 100, Mounting type: Snap into flat marker groove, For terminal block width: 5 mm, Lettering field: 5.15 x 5.15 mm

Surge protection device - PT-IQ-2X2-24DC-UT - 2800980

Accessories

Zack marker strip - ZBN 18:UNBEDRUCKT - 2809128



Zack marker strip, Strip, white, Unlabeled, Can be labeled with: Plotter, Mounting type: Snap into tall marker groove, For terminal block width: 18 mm, Lettering field: 18 x 5 mm

Electronic housing - E/ME TBUS NS35 GY - 2713780



End clamp, stable construction for DIN rail bus connector

Printed-circuit board connector - FK-MC 0,5/ 5-ST-2,5 - 1881354



Plug component, Nominal current: 4 A, Rated voltage (III/2): 160 V, Number of positions: 5, Pitch: 2.5 mm, Connection method: Spring-cage conn., Color: green, Contact surface: Tin

Additional products

Shield connection - SSA 3-6 - 2839295



shield fast connections for conductor diameter 3 - 6 mm. Potential connection cable: 200 mm, black

Shield connection - SSA 5-10 - 2839512



Shield fast connection for conductor diameters 5 - 10 mm. Potential connection cable: 200 mm, black

Surge protection device - PT-IQ-2X2-24DC-UT - 2800980

Drawings

Surge protection device - PT-IQ-2X2-24DC-UT - 2800980

Diagram

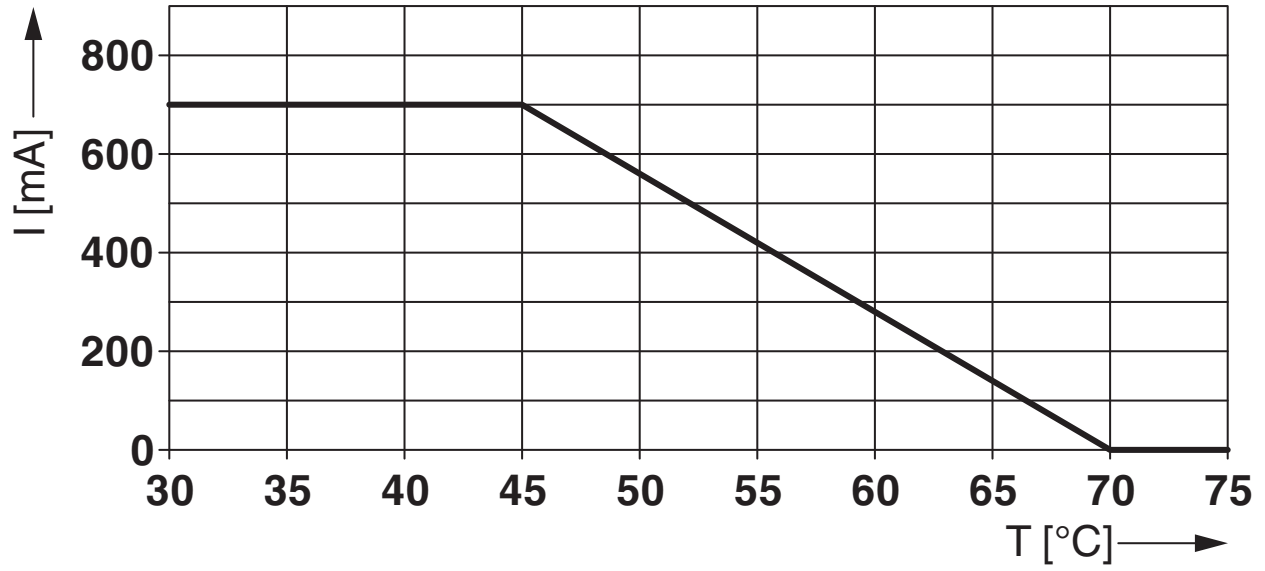

Surge protection device - PT-IQ-2X2-24DC-UT - 2800980

Dimensioned drawing

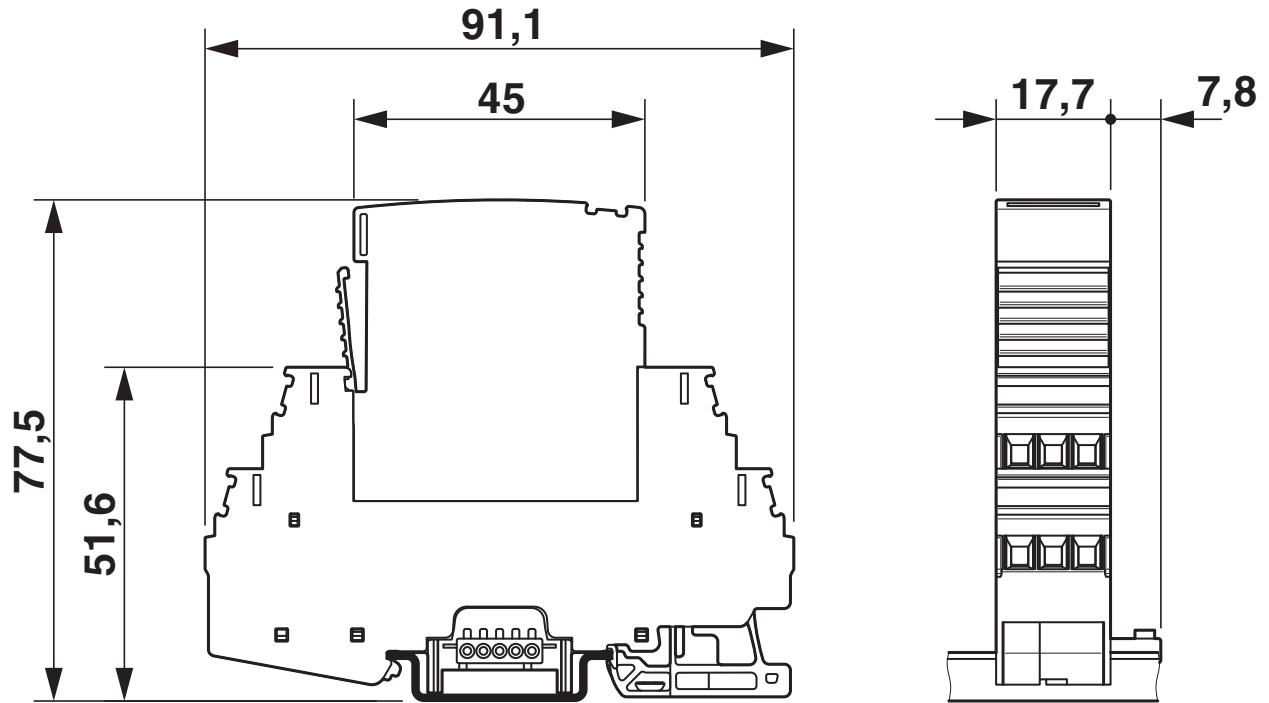

Surge protection device - PT-IQ-2X2-24DC-UT - 2800980

Circuit diagram

