



Principali caratteristiche

- 25 to 150 mm. stroke
- Mechanical linkage using joint with take up of play, M4 thread
- Independent linearity up to $\pm 0,05\%$
- Infinite resolution
- No variation of electrical signal outside theoretical electrical stroke
- Displacement speed up to 10 m/s
- Working temperature: $-30...+100^{\circ}\text{C}$
- Electrical connections:
 PY1 F 3 wire 1m screened cable
 PY1 C 5-pole connectors DIN43322
- Life duration: $> 100 \times 10^6$ operations (within C.E.U.)
- Double support of the control rod
- Grade of protection IP40

TECHNICAL DATA

Useful electrical stroke (C.E.U.)	25/50/75/100/150
Independent linearity (within C.E.U.)	see table
Displacement speed	≤ 10 m/s
Displacement force	$\leq 0.30\text{N}$
Vibrations	5...2000Hz, $A_{\text{max}} = 0,75$ mm $a_{\text{max}} = 20$ g
Shock	50 g, 11ms.
Tolerance on resistance	$\pm 20\%$
Recommended cursor current	$< 0,1 \mu\text{A}$
Maximum cursor current	10mA
Maximum applicable voltage	see table
Electrical isolation	$> 100\text{M}\Omega$ at 500V~, 1bar, 2s
Dielectric strength	$< 100 \mu\text{A}$ at 500V~, 50Hz, 2s, 1bar
Dissipation at 40°C (0W at 120°C)	see table
Temp. Coeff. of the resistance	$-200 \pm 200\text{ppm}/^{\circ}\text{C}$
Actual Temperature Coefficient of the output voltage	$< 1,5\text{ppm}/^{\circ}\text{C}$
Working temperature	$-30...+100^{\circ}\text{C}$
Storage temperature	$-50...+120^{\circ}\text{C}$
Case material	Anodised aluminium Nylon 66 GF 40
Control rod material	Stainless steel AISI 303
Fixing	Brackets with variable longitudinal axis

MECHANICAL DIMENSIONS

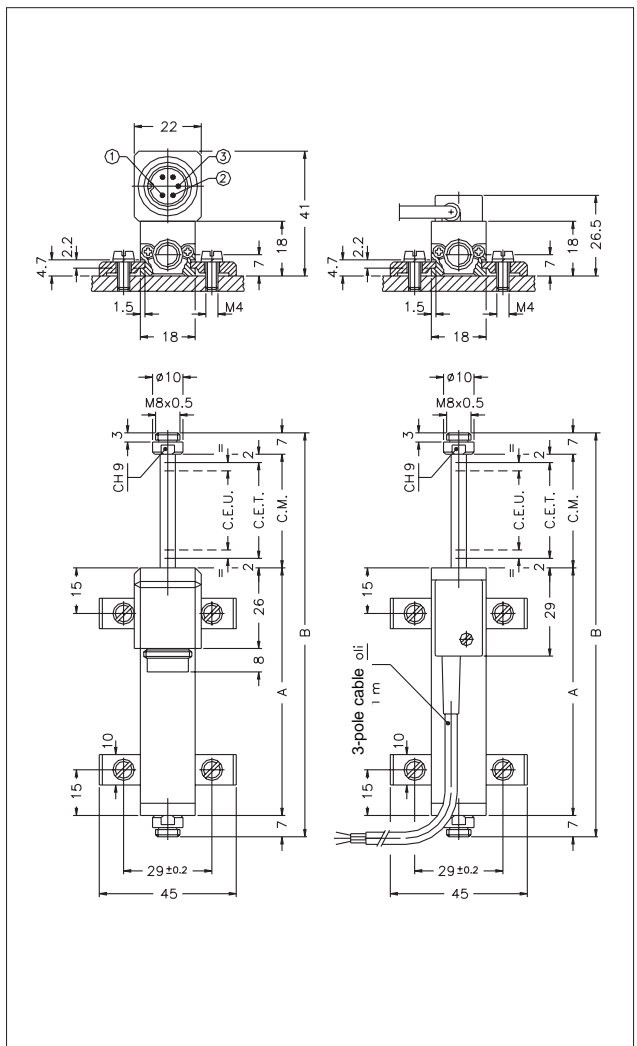

Important: all the data reported in the catalogue linearity, lifetime, temperature coefficient are valid for a sensor utilization as a ratiometric device with a max current across the cursor $I_c \leq 0.1 \mu\text{A}$.

MECHANICAL / ELECTRICAL DATA

MODEL		25	50	75	100	150
Useful electrical stroke (C.E.U.) +3/-0	mm	25	50	75	100	150
Theoretical electrical stroke (C.E.T.) ±1	mm	C.E.U. + 1				
Resistance (C.E.T.)	kΩ	1	5	5	5	5
Independent linearity (within C.E.U.)	± %	0,2	0,1	0,1	0,1	0,05
Dissipation at 40° (0W at 120°C)	W	0,6	1,2	1,8	2,5	3,6
Maximum applicable voltage	V	25	60			
Mechanical stroke (C.M.)	mm	C.E.U. + 5				
Case length (A)	mm	C.E.U. + 38				
Total length (B)	mm	107	157	207	257	357

COUPLING JOINT

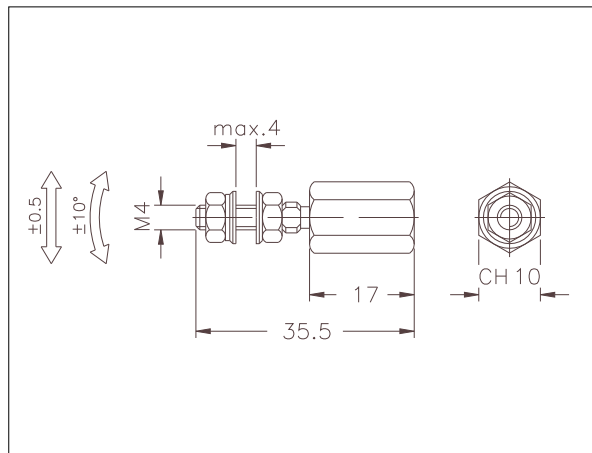

ELECTRICAL CONNECTIONS

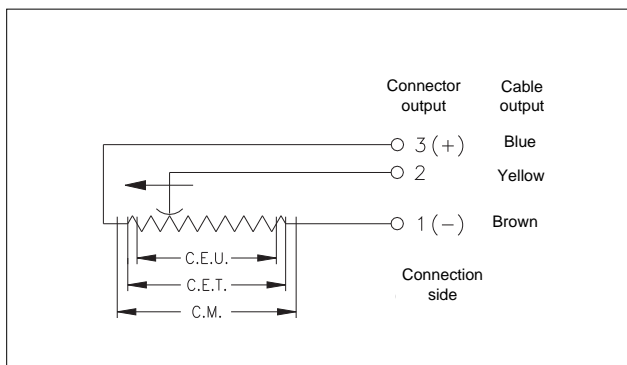

ORDER CODE

Displacement transducer **PY1**

Cable output	F
Connector output DIN43322	C

Model

3-pole PVC cable output 3x0,25 1meter	S
Connector output	----

If requested, it is possible to supply models with non-standard mechanical and/or electrical features

Example: PY1 - C - 100
Displacement transducer model PY1, 5-pole connector output, useful electrical stroke (C.E.U.) 100mm.

ACCESSORIES

STANDARD ACCESSORIES

Fixing kit for PY1 4 brackets, M4x10 screws, grower	Code PKIT005
Coupling joint	PKIT020

OPTIONAL ACCESSORIES

CON011 Protection IP40
CON012 Protection IP67
CON013 Protection IP40

Extraction length of the connector 10mm.

GEFRAN spa reserves the right to make any kind of design or functional modification at any moment without prior notice



GEFRAN spa
via Sebina, 74
25050 PROVAGLIO D'ISEO (BS) - ITALIA
ph. 0309888.1 - fax. 0309839063
Internet: <http://www.gefran.com>



cod. 84911-10/99