

# FHR1200

## Micro-Power, Ultra Wide Voltage Regulator

### Features

- Low Operating Current: 12  $\mu$ A Max.
- Option to Direct Drive Feedback Pin on PWM Controllers
- Programmable Output: 7.5 V to 100 V
- Wide Operating Temperature Range: -55°C to +150°C
- Output Voltage Accuracy:  $\pm 2\%$
- Excellent Output Voltage Compensation: -30 PPM/°C
- Sink Current Capability: 10  $\mu$ A to 50 mA
- Small Package: SC70-6 (SOT363)

### Applications

- Primary-Side Regulation in Flyback SMPS
- Secondary-Side Regulation in Flyback SMPS
- High Input Voltage SMPS
  - o Smart Meter
  - o Industrial Motor Control
  - o Wireless Infrastructure
- Industrial and Street Lighting LED Power Supplies

### Description

The FHR1200 is a high-efficiency regulator that outperforms the typical shunt regulator in applications where low operating power, wide temperature, and wide voltage range is important. The regulator also features better stability and faster response than many existing regulators.

Unlike the LM431 type of part, the FHR1200 can directly drive a power supply controller thus saving parts count and circuit complexity in many applications. This also makes the FHR1200 ideal for non-isolated secondary side, primary side, and floating regulation. Non-isolated secondary side regulation saves the cost of OPTOs and simplifies the power supply design.

The FHR1200 is very flexible and can be used in many diverse applications. For example:  $V_{CC}$  regulators to >100 volts, small additional auxiliary power supplies, programmable precision zener diodes (both high and low power), plus numerous analog circuits.

The FHR1200 is packaged in space-saving surface-mount SC70-6 (SOT363) to minimize layout space and cost.

### Typical Application

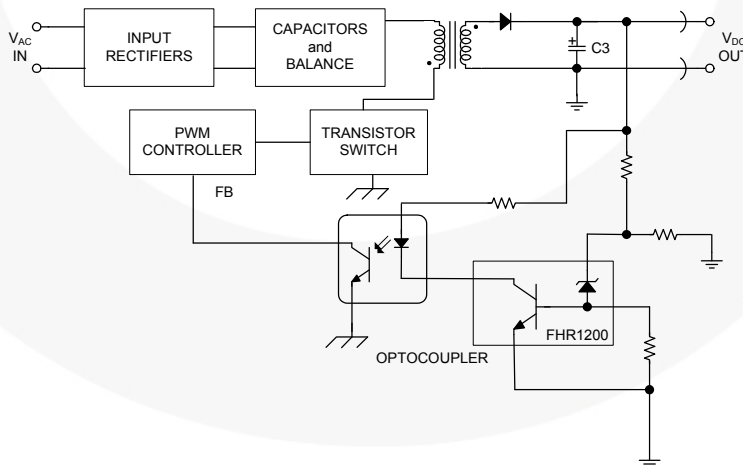


Figure1. Flyback Power Supply Secondary-Side Regulation

### Ordering Information

Part Number	Top Mark	Package	Packing Method	Remarks
FHR1200	FH	SC70-6 (SOT363)	Tape and Reel	3000 pcs, Reel Size is 7"

## Block Diagram

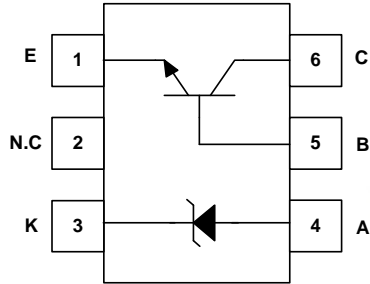


Figure 2. Internal Connection

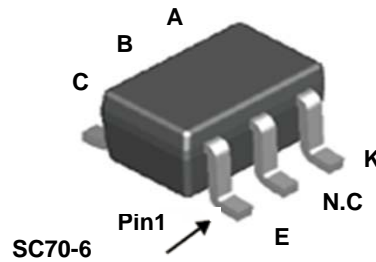


Figure 3. Device Package

## Pin Definitions

Pin #	Pin Name	Description
1	E	Ground Connection
2	N.C	No Connection
3	K	Reference Voltage
4	A	Ref Bias Pin: Tie R4 to ground to bias; Tie cap to ground for lower noise
5	B	Reference Bias Pin
6	C	Regulator Output

## Absolute Maximum Ratings

Stresses exceeding the absolute maximum ratings may damage the device. The device may not function or be operable above the recommended operating conditions and stressing the parts to these levels is not recommended. In addition, extended exposure to stresses above the recommended operating conditions may affect device reliability. The absolute maximum ratings are stress ratings only. Values are at  $T_A = 25^\circ\text{C}$  unless otherwise noted.

Symbol	Parameter	Value	Unit
$V_{OUT}$	Regulator Output	100	V
$I_{BIAS}$	Cathode Current	50	mA
$P_D$	Power Dissipation	$T_A = 25^\circ\text{C}$ 227	mW
$T_J, T_{STG}$	Operating and Storage Junction Temperature Range	-55 to +150	$^\circ\text{C}$

## Thermal Characteristics<sup>(1)</sup>

Symbol	Parameter	Value	Unit
$R_{\theta JA}$	Thermal Resistance, Junction to Air	550	$^\circ\text{C}/\text{W}$
$\Psi_{JB}$	Junction to Board Thermal Characterization Parameter	370	$^\circ\text{C}/\text{W}$

### Note:

- PCB Board Size: FR4 76 x 114 x 0.6 T mm<sup>3</sup> (3.0 inch x 4.5 inch x 0.062 inch) with minimum land pattern size.  
 $\Psi_{JB}$  test method: T-36 gauge thermocouple is soldered directly to the collector lead pin about 1 mm distance from package lead.

## Electrical Characteristics

Values are at  $T_A = 25^\circ\text{C}$  unless otherwise noted.

Symbol	Parameter	Conditions	Min.	Typ.	Max.	Units	
$V_{REF}$	Reference Voltage (Zener + Base Emitter Voltage)	$V_{OUT} = V_{REF}$ , Fig. 4, $V_{CC} = 17.3\text{ V}$ , Accuracy = $\pm 2\%$ , $I_Z = 25\ \mu\text{A}$	$R3 = 49.9\ \text{k}\Omega$ , $I_{REF} = 1\ \mu\text{A}$ , $R4 = 23.2\ \text{k}\Omega$ , $I_{CC} = 200\ \mu\text{A}$	7.115	7.260	7.405	V
$TCV_{REF}$	Temperature Coefficient <sup>(2)</sup>	$V_{OUT} = V_{REF}$ , Fig. 4, Accuracy = $\pm 2\%$ , $T_A = 0$ to $+100^\circ\text{C}$ to $T_A = -40$ to $+125^\circ\text{C}$	$R3 = 49.9\ \text{k}\Omega$ , $I_{REF} = 1\ \mu\text{A}$ , $R4 = 9.53\ \text{k}\Omega$ , $I_{CC} = 200\ \mu\text{A}$ , $I_Z = 60\ \mu\text{A}$ , $V_{CC} = 10\ \text{V}$		29		PPM/ $^\circ\text{C}$
$\frac{\Delta V_{REF}}{\Delta V_{OUT}}$	Ratio of the Change in Reference Voltage to the Change in Cathode Voltage	Fig. 5, $V_{CC} = V_{OUT} + 20\ \text{V}$ , $I_Z = 25\ \mu\text{A}$ , $V_{OUT} = V_{REF} + 75\text{V}$ , $R5 =$ <sup>(3)</sup>	$R3 = 100\ \text{k}\Omega$ , $R2 = 53.6\ \text{k}\Omega$ , $R1 = 0$   $499\ \text{k}\Omega$ , $R4 = 23.2\ \text{k}\Omega$ , $I_{CC} = 200\ \mu\text{A}$ , $I_{REF} = 150\ \mu\text{A}$		0.024	0.200	mV/V
$I_Z$	Reference Input Current	$I_{CC} = 1.0\ \text{mA}$ , Fig. 5, $V_{CC} = 17.3\ \text{V}$ , $R1 = 10.0\ \text{k}\Omega$ , $R2 =$ , $R3 = 100\ \text{k}\Omega$ , $R4 = 499\ \text{k}\Omega$ , $R5 =$ <sup>(4)</sup>			7.7	12.0	$\mu\text{A}$
$\Delta I_Z / \Delta T$	Deviation of Reference $I_Z$ Over Temperature				5.45		$\mu\text{A}/^\circ\text{C}$
$\frac{\Delta V_{REF}}{\Delta I_{CC}}$	Output Impedance	Fig. 4, $V_{OUT} = V_{REF}$ , $V_{CC} = 15.4$   $19.4\ \text{V}$ , $I_Z = 25\ \mu\text{A}$ , $f = 0\ \text{Hz}$ , $R5 =$ <sup>(5)</sup>	$I_{CC} = 160$   $240\ \mu\text{A}$ , $R3 = 49.9\ \text{k}\Omega$ , $R4 = 23.2\ \text{k}\Omega$		154	300	$\Omega$
$e_n$	Output Noise Voltage <sup>(6)</sup>	$V_{OUT} = V_{REF}$ , Fig. 6, $I_{CC} = 1.0\ \text{mA}$ , $V_{CC} = 17.3\ \text{V}$ , $V_{REF} = 7.35\ \text{V}$ , $I_Z = 25\ \mu\text{A}$ , $R3 = 15.00\ \text{k}\Omega$ , $R4 = 28.7\ \text{k}\Omega$ , $f = 400\ \text{Hz}$ to $100\ \text{KHz}$	$C_N = n/a$ , $C_L = n/a$ $C_N = 0.1\ \mu\text{F}$ , $C_L = n/a$ $C_N = n/a$ , $C_L = 0.1\ \mu\text{F}$ $C_N = 0.1\ \mu\text{F}$ , $C_L = 0.1\ \mu\text{F}$		141.0		$\mu\text{Vrms}$
GBW (3db)	Gain Bandwidth Product	$I_{CC} = 1.0\ \text{mA}$ , $V_{CC} = 27\ \text{V}_{DC}$ , $V_{IN} = 2\ \text{Vp-p}$ , $I_{B1} = 5\ \mu\text{A}$ , $I_Z = 25\ \mu\text{A}$ , $C_G C_L =$ , $C_N = 0.1\ \mu\text{F}$ , $R1 = 23.2\ \text{k}\Omega$ , $R2 = 39.2\ \text{k}\Omega$ , $R3 = 15\ \text{k}\Omega$ , $R4 = 28.7\ \text{k}\Omega$ , $R5 = 22\ \text{k}\Omega$ , $V_{OUT} = 12\ \text{V}$ , $I_{REF} = 200\ \mu\text{A}$ , Gain = -1, Fig. 7			4.47		MHz
SR	Slew Rate	$I_{CC} = 1.0\ \text{mA}$ , $V_{CC} = 27\ \text{V}_{DC}$ , $V_{IN} = 2\ \text{Vp-p}$ , $I_{B1} = 5\ \mu\text{A}$ , $I_Z = 25\ \mu\text{A}$ , $C_G C_L =$ , $C_N = 0.1\ \mu\text{F}$ , $R1 = 23.2\ \text{k}\Omega$ , $R2 = 39.2\ \text{k}\Omega$ , $R3 = 15\ \text{k}\Omega$ , $R4 = 28.7\ \text{k}\Omega$ , $R5 = 22\ \text{k}\Omega$ , $V_{OUT} = 12\ \text{V}$ , $I_{REF} = 200\ \mu\text{A}$ , Gain = -1, Fig. 7			18.8		V/ $\mu\text{s}$

### Notes:

2. The deviation parameters  $V_{REF(\text{dev})}$  and  $I_{REF(\text{dev})}$  are defined as the differences between the maximum and minimum values obtained over the rated temperature range. The average full-range temperature coefficient of the reference input voltage,  $TCV_{REF}$ , is defined as:

$$TCV_{REF} \left( \frac{\text{ppm}}{^\circ\text{C}} \right) = \frac{\left( \frac{V_{REF(\text{dev})}}{V_{REF}(T_A=25^\circ\text{C})} \right) * 10^6}{\Delta T} \quad (T_A): \text{ Ambient Temperature}$$

$V_{REF(\text{dev})}$ :  $V_{REF}$  deviation over full temperature range

where  $\Delta T$  is the rated operating free-air temperature range of the device.

$TCV_{REF}$  can be positive or negative, depending on whether minimum  $V_{REF}$  or maximum  $V_{REF}$ , respectively, occurs at the lower temperature.

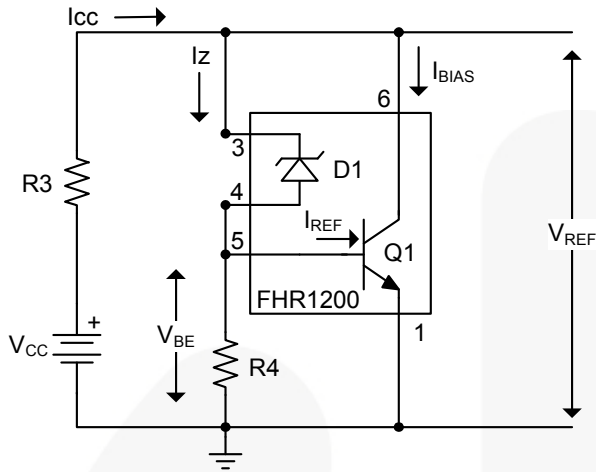
$$3. \quad \frac{\Delta V_{REF}}{\Delta V_{OUT}} = \text{ABS} \left| \frac{V_{REF1} - V_{REF2}}{V_{OUT1} - V_{OUT2}} \right|$$

$$4. \quad I_Z = \frac{V_{REF} - V_{OUT}}{R1}$$

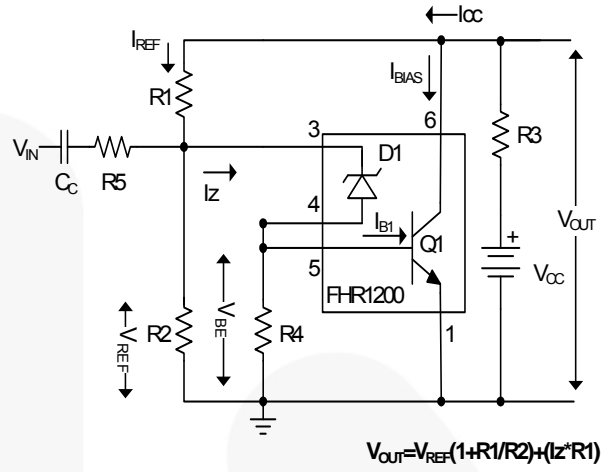
$$5. \quad Z_{OUT} = \frac{V_{REF2} - V_{REF1}}{I_{CC2} - I_{CC1}}$$

6. For testing: a) hfe typical ~200; b) all resistors are metal film; c) all capacitors are plastic film.

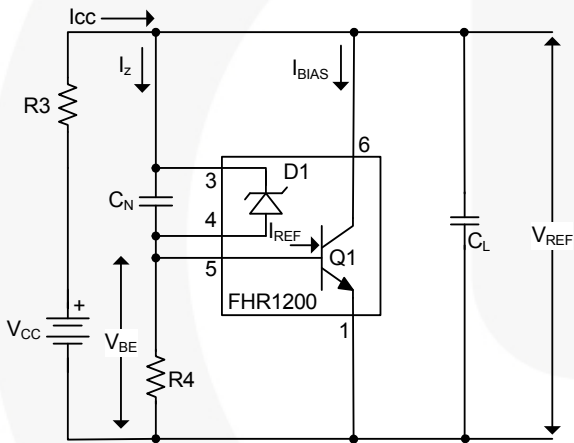
**Test Circuit**



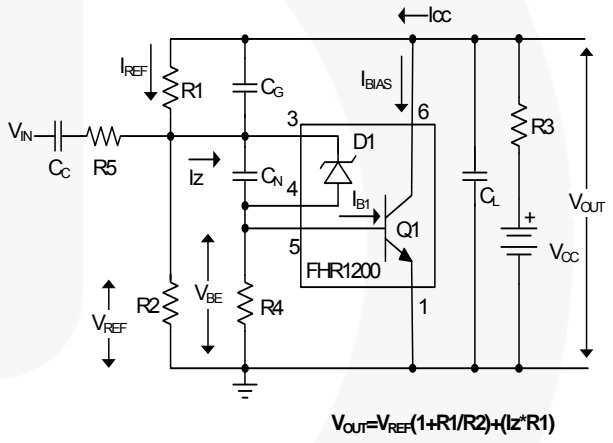
**Figure 4. Test Configured:  $V_{REF} = V_{OUT}$**



**Figure 5. Test Configured:  $V_{REF} < V_{OUT}$**

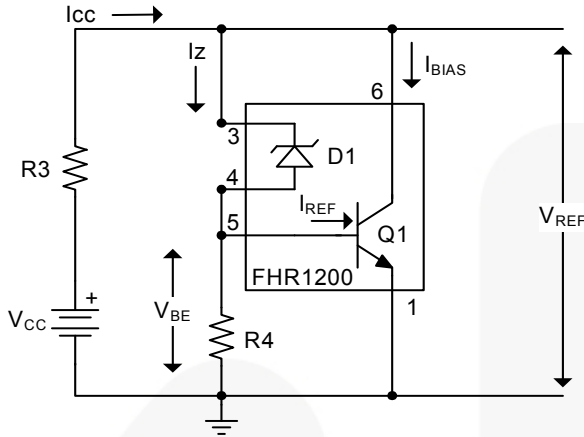


**Figure 6. Test Configured:  $V_{REF} = V_{OUT}$  with Capacitance**

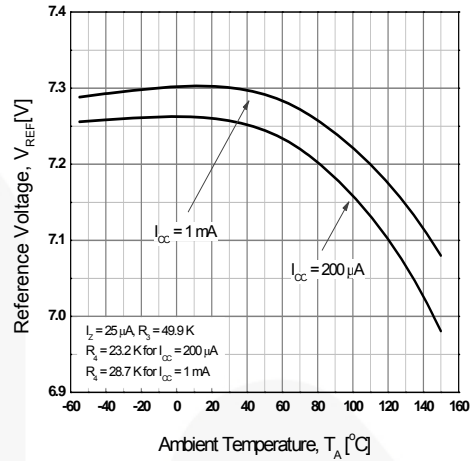


**Figure 7. Test Configured:  $V_{REF} < V_{OUT}$  with Capacitance**

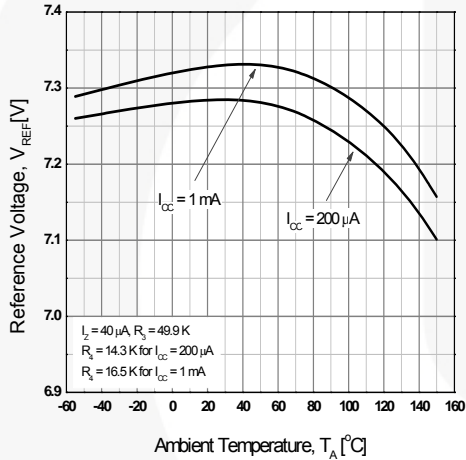
### Typical Characteristics: $V_{REF}$



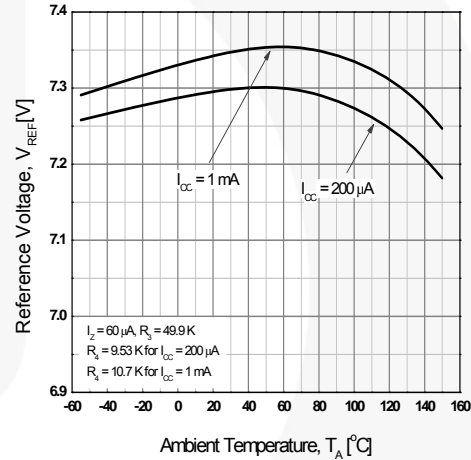
**Figure 8. Test Diagram:  $V_{REF} = V_{OUT}$  (Fixed Value of  $R_4$ )**



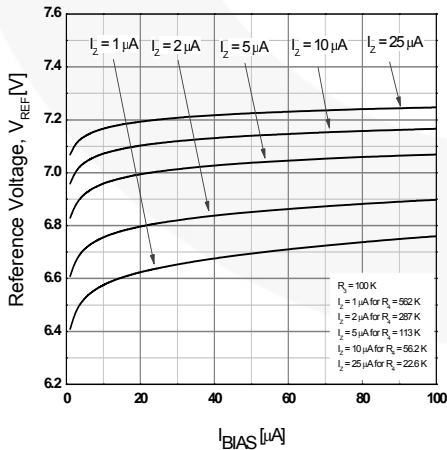
**Figure 9. Reference Voltage vs. Ambient Temperature (Fixed Value  $R_4$ ,  $I_Z \sim 25\text{ }\mu\text{A}$  at  $25^\circ\text{C}$ )**



**Figure 10. Reference Voltage vs. Ambient Temperature (Fixed Value  $R_4$ ,  $I_Z \sim 40\text{ }\mu\text{A}$  at  $25^\circ\text{C}$ )**

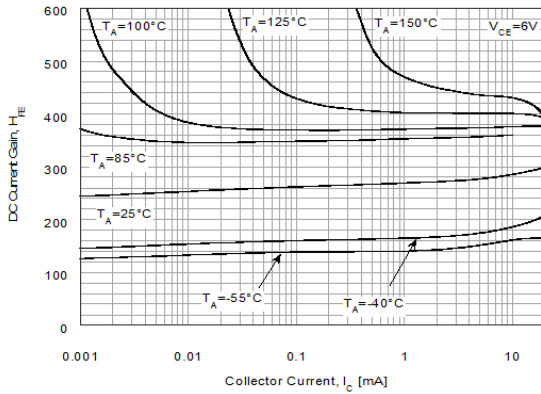


**Figure 11. Reference Voltage vs. Ambient Temperature (Fixed Value  $R_4$ ,  $I_Z \sim 60\text{ }\mu\text{A}$  at  $25^\circ\text{C}$ )**

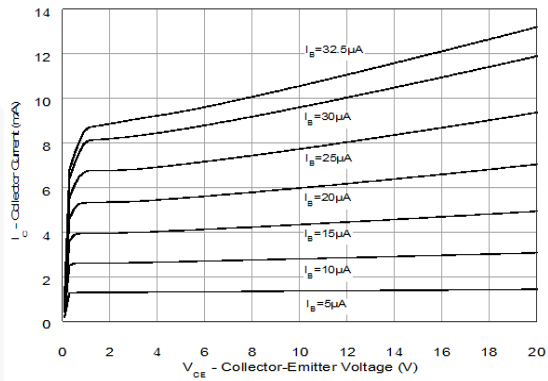


**Figure 12. Minimum Cathode Current for Regulation**

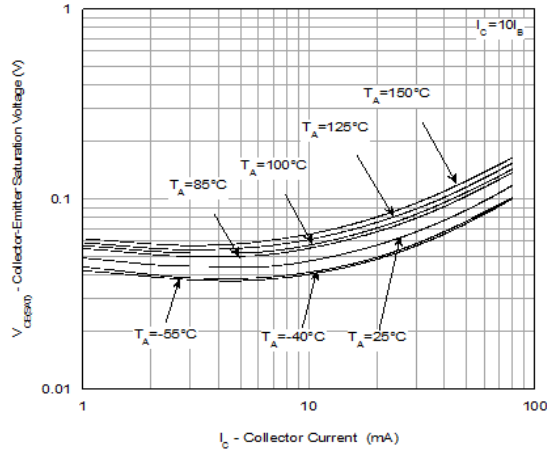
**Typical Characteristics (Continued)**



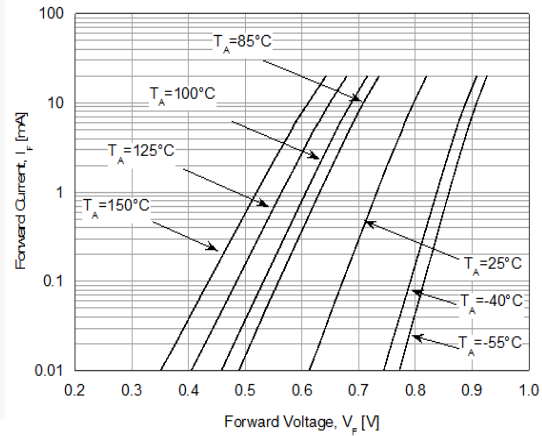
**Figure 13. DC Current Gain vs. Collector Current**



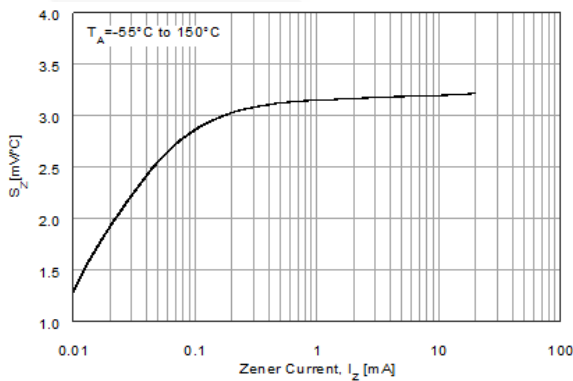
**Figure 14. Common Emitter Output Characteristics**



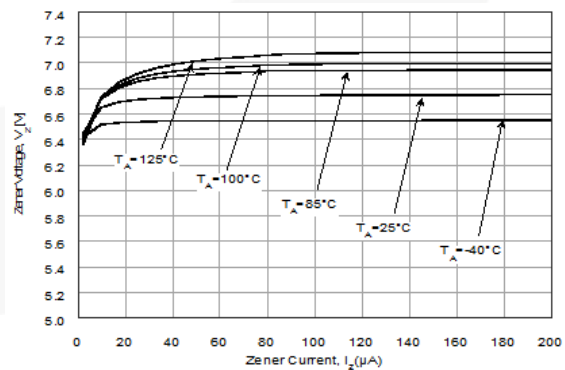
**Figure 15. Collection-Emitter Saturation Voltage vs. Collector Current**



**Figure 16. Typical Forward Voltage**



**Figure 17. Typical Temperature Coefficient as Function of Working Current**



**Figure 18. Zener Voltage vs. Applied Current**

Typical Characteristics (Continued)

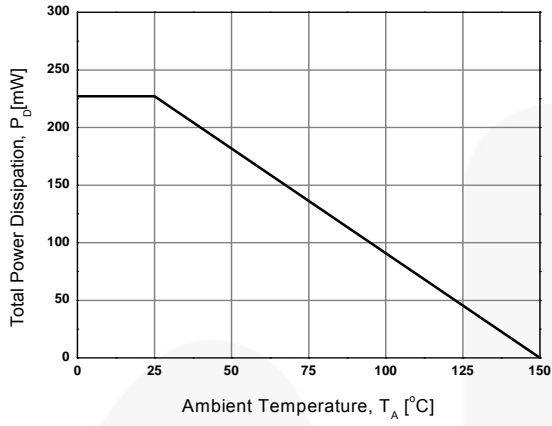


Figure 19. Power Derating

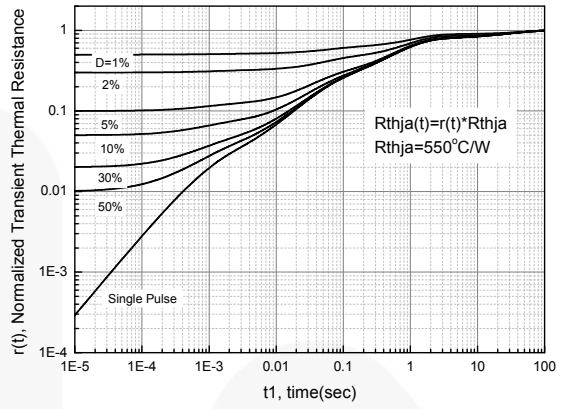


Figure 20. Transient Thermal Resistance

Typical Applications (Continued)

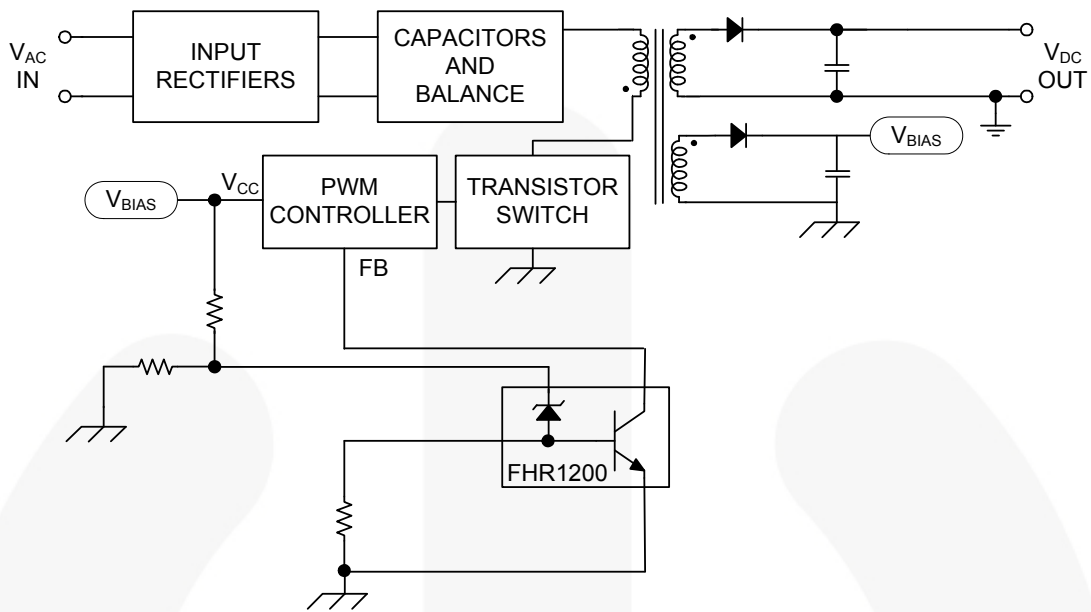


Figure 21. Flyback Power Supply Primary-Side Regulation

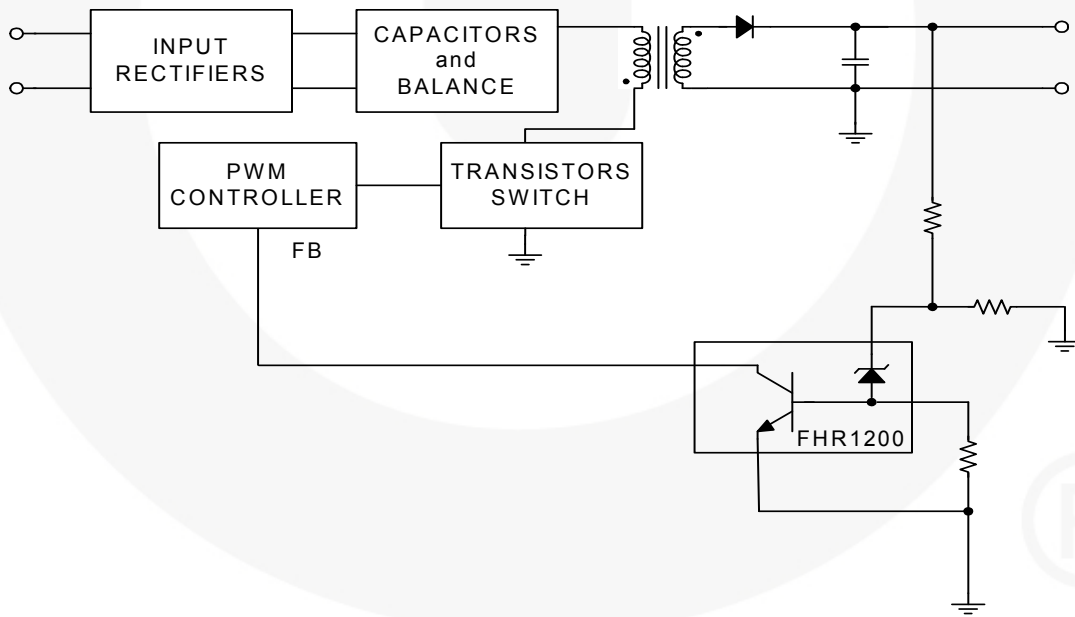
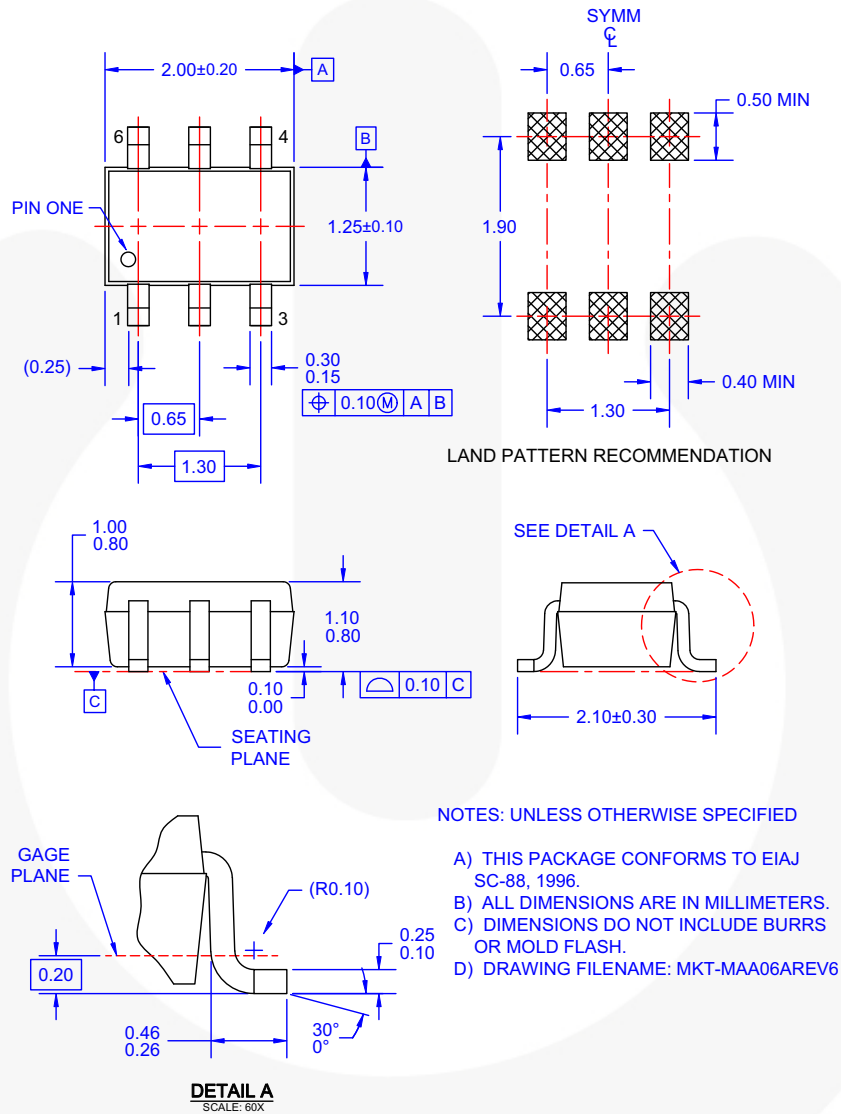


Figure 22. Flyback Power Supply Non-Isolated Secondary-Side Regulation

## Physical Dimensions

### SC70-6 (SOT363)



**Figure 23. 6-Lead, SC-70, EIAJ SC-88, 1.25 MM WIDE**

Package drawings are provided as a service to customers considering Fairchild components. Drawings may change in any manner without notice. Please note the revision and/or date on the drawing and contact a Fairchild Semiconductor representative to verify or obtain the most recent revision. Package specifications do not expand the terms of Fairchild's worldwide terms and conditions, specifically the warranty therein, which covers Fairchild products.






Always visit Fairchild Semiconductor's online packaging area for the most recent package drawings:  
<http://www.fairchildsemi.com/dwg/MA/MAA06A.pdf>

For current tape and reel specifications, visit Fairchild Semiconductor's online packaging area:  
[http://www.fairchildsemi.com/packaging\\_dwg/PKG-MAA06A.pdf](http://www.fairchildsemi.com/packaging_dwg/PKG-MAA06A.pdf)



**TRADEMARKS**

The following includes registered and unregistered trademarks and service marks, owned by Fairchild Semiconductor and/or its global subsidiaries, and is not intended to be an exhaustive list of all such trademarks.

AccuPower™	F-PFS™		Sync-Lock™
AX-CAP®*	FRFET®	PowerTrench®	
BitSiC™	Global Power Resource™	PowerXS™	TinyBoost®
Build it Now™	GreenBridge™	Programmable Active Droop™	TinyBuck®
CorePLUS™	Green FPS™	QFET®	TinyCalc™
CorePOWER™	Green FPS™ e-Series™	QS™	TinyLogic®
CROSSVOLT™	Gmax™	Quiet Series™	TINYOPTO™
CTL™	GTO™	RapidConfigure™	TinyPower™
Current Transfer Logic™	IntelliMAX™		TinyPWM™
DEUXPEED®	ISOPLANAR™	Saving our world, 1mW/W/kW at a time™	TinyWire™
Dual Cool™	Making Small Speakers Sound Louder and Better™	SignalWise™	TranSiC™
EcoSPARK®	MegaBuck™	SmartMax™	TriFault Detect™
EfficientMax™	MICROCOUPLER™	SMART START™	TRUECURRENT®*
ESBC™	MicroFET™	Solutions for Your Success™	µSerDes™
	MicroPak™	SPM®	
Fairchild®	MicroPak2™	STEALTH™	UHC®
Fairchild Semiconductor®	MillerDrive™	SuperFET®	Ultra FRFET™
FACT Quiet Series™	MotionMax™	SuperSOT™-3	UniFET™
FACT®	mWSaver®	SuperSOT™-6	VCX™
FAST®	OptoHiT™	SuperSOT™-8	VisualMax™
FastvCore™	OPTOLOGIC®	SupreMOS®	VoltagePlus™
FETBench™	OPTOPLANAR®	SyncFET™	XS™
FPS™			

\* Trademarks of System General Corporation, used under license by Fairchild Semiconductor.

**DISCLAIMER**

FAIRCHILD SEMICONDUCTOR RESERVES THE RIGHT TO MAKE CHANGES WITHOUT FURTHER NOTICE TO ANY PRODUCTS HEREIN TO IMPROVE RELIABILITY, FUNCTION, OR DESIGN. FAIRCHILD DOES NOT ASSUME ANY LIABILITY ARISING OUT OF THE APPLICATION OR USE OF ANY PRODUCT OR CIRCUIT DESCRIBED HEREIN; NEITHER DOES IT CONVEY ANY LICENSE UNDER ITS PATENT RIGHTS, NOR THE RIGHTS OF OTHERS. THESE SPECIFICATIONS DO NOT EXPAND THE TERMS OF FAIRCHILD'S WORLDWIDE TERMS AND CONDITIONS, SPECIFICALLY THE WARRANTY THEREIN, WHICH COVERS THESE PRODUCTS.

**LIFE SUPPORT POLICY**

FAIRCHILD'S PRODUCTS ARE NOT AUTHORIZED FOR USE AS CRITICAL COMPONENTS IN LIFE SUPPORT DEVICES OR SYSTEMS WITHOUT THE EXPRESS WRITTEN APPROVAL OF FAIRCHILD SEMICONDUCTOR CORPORATION.

As used herein:

1. Life support devices or systems are devices or systems which, (a) are intended for surgical implant into the body or (b) support or sustain life, and (c) whose failure to perform when properly used in accordance with instructions for use provided in the labeling, can be reasonably expected to result in a significant injury of the user.
2. A critical component in any component of a life support, device, or system whose failure to perform can be reasonably expected to cause the failure of the life support device or system, or to affect its safety or effectiveness.

**ANTI-COUNTERFEITING POLICY**

Fairchild Semiconductor Corporation's Anti-Counterfeiting Policy. Fairchild's Anti-Counterfeiting Policy is also stated on our external website, [www.fairchildsemi.com](http://www.fairchildsemi.com), under Sales Support.

Counterfeiting of semiconductor parts is a growing problem in the industry. All manufacturers of semiconductor products are experiencing counterfeiting of their parts. Customers who inadvertently purchase counterfeit parts experience many problems such as loss of brand reputation, substandard performance, failed applications, and increased cost of production and manufacturing delays. Fairchild is taking strong measures to protect ourselves and our customers from the proliferation of counterfeit parts. Fairchild strongly encourages customers to purchase Fairchild parts either directly from Fairchild or from Authorized Fairchild Distributors who are listed by country on our web page cited above. Products customers buy either from Fairchild directly or from Authorized Fairchild Distributors are genuine parts, have full traceability, meet Fairchild's quality standards for handling and storage and provide access to Fairchild's full range of up-to-date technical and product information. Fairchild and our Authorized Distributors will stand behind all warranties and will appropriately address any warranty issues that may arise. Fairchild will not provide any warranty coverage or other assistance for parts bought from Unauthorized Sources. Fairchild is committed to combat this global problem and encourage our customers to do their part in stopping this practice by buying direct or from authorized distributors.

**PRODUCT STATUS DEFINITIONS**

**Definition of Terms**

Datasheet Identification	Product Status	Definition
Advance Information	Formative / In Design	Datasheet contains the design specifications for product development. Specifications may change in any manner without notice.
Preliminary	First Production	Datasheet contains preliminary data; supplementary data will be published at a later date. Fairchild Semiconductor reserves the right to make changes at any time without notice to improve design.
No Identification Needed	Full Production	Datasheet contains final specifications. Fairchild Semiconductor reserves the right to make changes at any time without notice to improve the design.
Obsolete	Not In Production	Datasheet contains specifications on a product that is discontinued by Fairchild Semiconductor. The datasheet is for reference information only.