

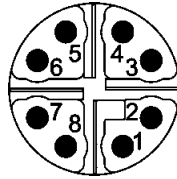

Mating face



X-coding  
Mating face  
acc. to IEC 61076-2-101



## Applications / Advantages

- High-Speed Ethernet applications for process automatization, e.g. camera system for process control in the production
- Maximum data rates through the configuration of the contacts in conformance with Ethernet technology. Transfer class E<sub>A</sub> for 1 and 10 Gigabit
- Perfect shielding through paired shielding of the contacts
- Overmoulded system cables in various lengths

04

### Identification

### Part No.

### Drawing

### Dimensions in mm

#### har-speed M12



Male  
straight version  
8 poles, Cat. 6<sub>A</sub>  
Cable diameter: 4.5 - 8.8 mm

21 03 881 5805

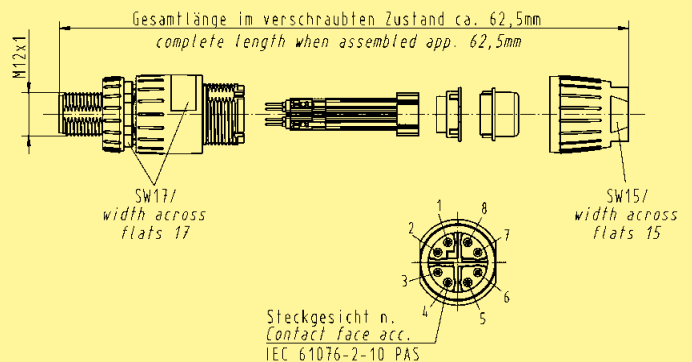

#### har-speed M12 Slim design



Male  
straight version  
8 poles, Cat. 6<sub>A</sub>  
Cable diameter: 4.5 - 8.8 mm

21 03 881 1805

