

14 TURNS CERMET TRIMMERS

RJ-5

RoHS compatible



FEATURES

- Lead-free soldering, Cadmium-free
- Fine setting is possible
- Sealed construction (Washable)

INTERNAL STRUCTURE

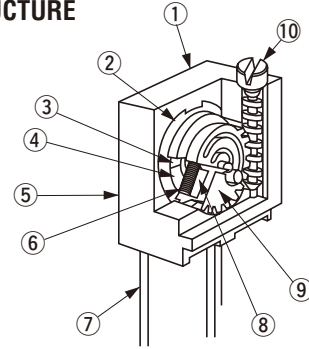

Part name		Material	Flammability
①	Housing	PBT (Polybutyleneterephthalate)	UL-94V-0
②	Base element	Ceramic	—
③	Electrode	Ag-Pd cermet	
④	Resistive element	RuO ₂ cermet	
⑤	Adhesive	Epoxy	
⑥	Wiper	Multi metal alloy	
⑦	Terminal pin	Sn-Pb	
		Sn	Copper, Tin-plated
⑧	Rubber cushion	Silicone rubber	UL-94HB
⑨	Rotor gear	PA (Polyamide)	
⑩	Shaft	Brass, Nickel-plated	—

CFCs, Halon, Carbon tetrachloride and designated bromic flame retardant PBBs and PBBs are not used in our products.

PART NUMBER DESIGNATION

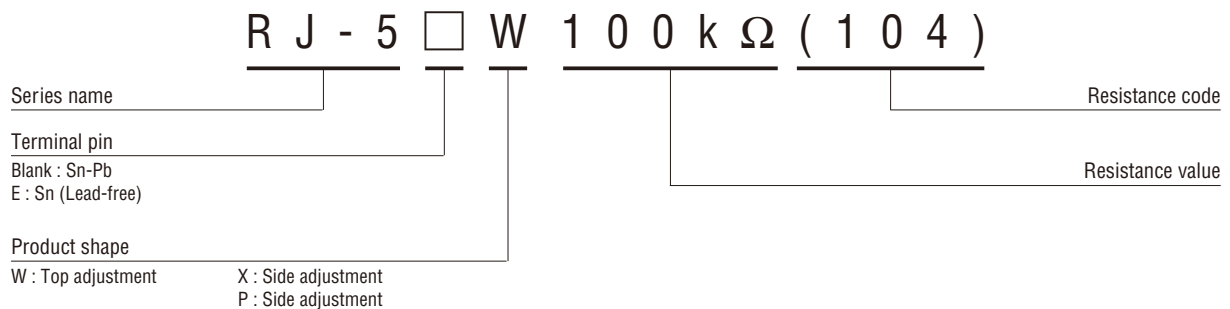

✳ Please refer to the LIST OF PART NUMBERS when placing orders.

■ Specifications are subject to change without notice. Specifications in this catalog are for reference. The formal specification sheets will be submitted upon request.

LIST OF PART NUMBERS

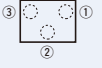
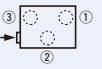
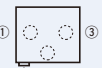
Adjustment position	Shape of terminal (Top view)	Form of packaging		Pieces in package
		Vinyl bag		
		Sn-Pb	Sn (Lead-free)	
Top adjustment 		RJ-5W	RJ-5EW	50 pcs./pack
Side adjustment (↑ Adjustment direction)		RJ-5X	RJ-5EX	
		RJ-5P	RJ-5EP	

ELECTRICAL CHARACTERISTICS

Nominal resistance range	10 Ω ~ 2 MΩ
Resistance tolerance	± 10 %
Power ratings	0.25 W (85 °C) 0 W (120 °C)
Resistance law	Linear law (B)
Maximum input voltage	DC200 V or power rating, whichever is smaller
Maximum wiper current	100 mA or power rating, whichever is smaller
Effective electrical turn	11 turns
End resistance	1 % or 2 Ω, whichever is greater
C.R.V.	1 % or 3 Ω, whichever is greater
Operating temp. range	-55 ~ 120 °C
Temp. coefficient	10 Ω ~ 50 Ω : ± 250 10 ⁻⁶ /°C maximum 100 Ω ~ 2 MΩ : ± 100 10 ⁻⁶ /°C maximum
Insulation resistance	1000 MΩ minimum (DC500 V)
Dielectric strength	AC600 V, 60 s
Net weight	Approx. 0.37 g

<Nominal resistance values>

⊕10 Ω	⊕20 Ω	50 Ω	100 Ω	200 Ω	500 Ω	1 kΩ	2 kΩ	5 kΩ
10 kΩ	20 kΩ	50 kΩ	100 kΩ	200 kΩ	500 kΩ	1 MΩ	2 MΩ	

Fig. 1

The products indicated by ⊕ mark are manufactured upon receipt of order basis.

- * : The above part numbers are all available with the respective combination of <Nominal resistance values> (Fig. 1).
- * : Verify the above part numbers when placing orders.

MECHANICAL CHARACTERISTICS

Mechanical turn	14 turns
Operating torque	20 mN·m (204 gf·cm) maximum
Mechanical stop	Clutch action
Rotational life	200 cycles 10 Ω ~ 200 Ω [Δ R/R ≤ ± (0.5 Ω + 3 %)] 500 Ω ~ 2 MΩ [Δ R/R ≤ ± (0.5 Ω + 2 %)]
Terminal strength	10 N {1.02 kgf} minimum (Tensile strength)
Thrust to shaft	5 N {0.51 kgf} minimum
Solderability	Sn-Pb : 235 °C, 2 s Sn (Lead-free) : 245 ± 3 °C, 2 ~ 3 s

{ } : Reference only

ENVIRONMENTAL CHARACTERISTICS

Test item	Test conditions	Specifications
Thermal shock	-65 ~ 125 °C (0.5 h), 5 cycles	[Δ R/R ≤ 1 %] [S.S. ≤ 1 %]
Humidity	-10 ~ 65 °C (Relative humidity 80 ~ 98 %), 10 cycles, 240 h	[Δ R/R ≤ 1 %]
Shock	981 m/s ² , 6 ms 6 directions for 3 times each	[Δ R/R ≤ 1 %] [S.S. ≤ 1 %]
Vibration	Amplitude 1.52 mm or Acceleration 196 m/s ² , 10 ~ 2000 Hz, 3 directions, 12 times each	
Load life	85 °C, 0.25 W, 1000 h	[Δ R/R ≤ 2 %] [S.S. ≤ 1 %]
Low temp. operation	-55 °C, 2 h	[Δ R/R ≤ 2 %] [S.S. ≤ 2 %]
High temp. exposure	120 °C, 250 h	
Immersion seal	85 °C, 60 s	No leaks (No continuous bubbles)
Soldering heat	Sn-Pb 350 °C, 3 s Sn Flow soldering : 260 ± 3 °C, 5 ~ 6 s, two times maximum Manual soldering : 380 ± 10 °C, 3 ~ 4 s	[Δ R/R ≤ 1 %]

Δ R/R : Change in total resistance
S.S. : Setting stability

MAXIMUM INPUT RATINGS

Nominal resistance values (Ω)	Resistance code	Maximum input voltage (V)	Maximum wiper current (mA)
↻ 10	100	1.00	100
↻ 20	200	2.00	100
↻ 50	500	3.53	70.7
↻ 100	101	5.00	50.0
↻ 200	201	7.07	35.3
↻ 500	501	11.1	22.3
1 k	102	15.8	15.8
2 k	202	22.3	11.1
5 k	502	35.3	7.07
10 k	103	50.0	5.00
20 k	203	70.7	3.53
50 k	503	111	2.23
100 k	104	158	1.58
200 k	204	200	1.00
500 k	504	200	0.40
1 M	105	200	0.20
2 M	205	200	0.10

The products indicated by ↻ mark are manufactured upon receipt of order basis.

OUTLINE DIMENSIONS

Unless otherwise specified, tolerance: ± 0.3 (Unit: mm)

**RJ-5W, RJ-5EW
Top adjustment**

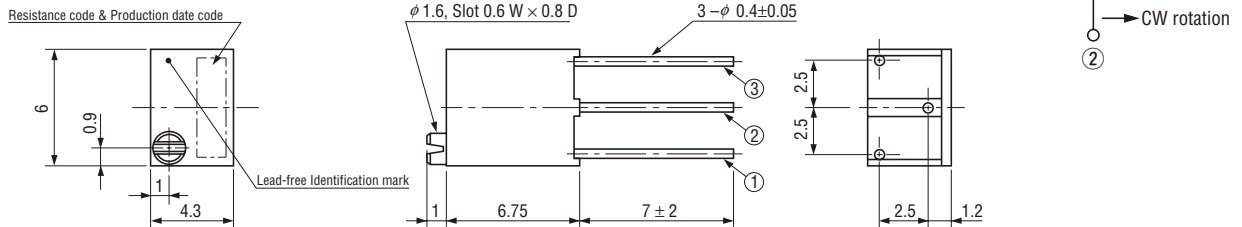

**RJ-5X, RJ-5EX
Side adjustment**

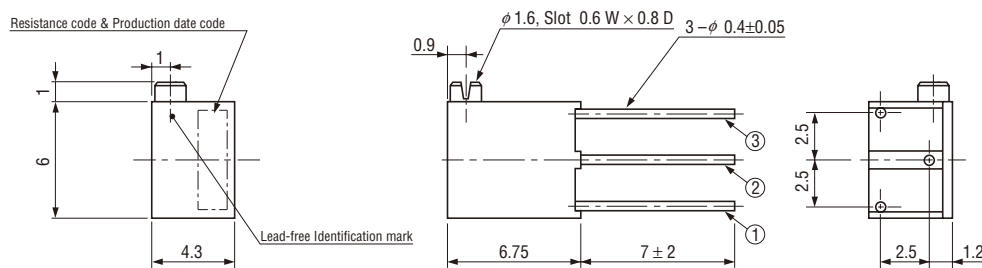

**RJ-5P, RJ-5EP
Side adjustment**

