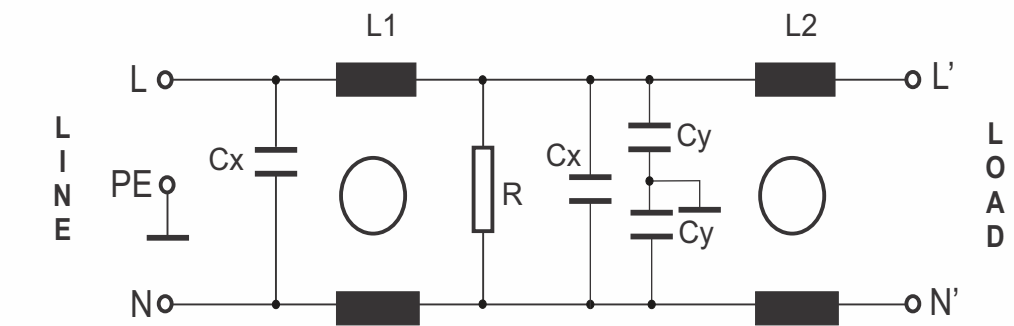
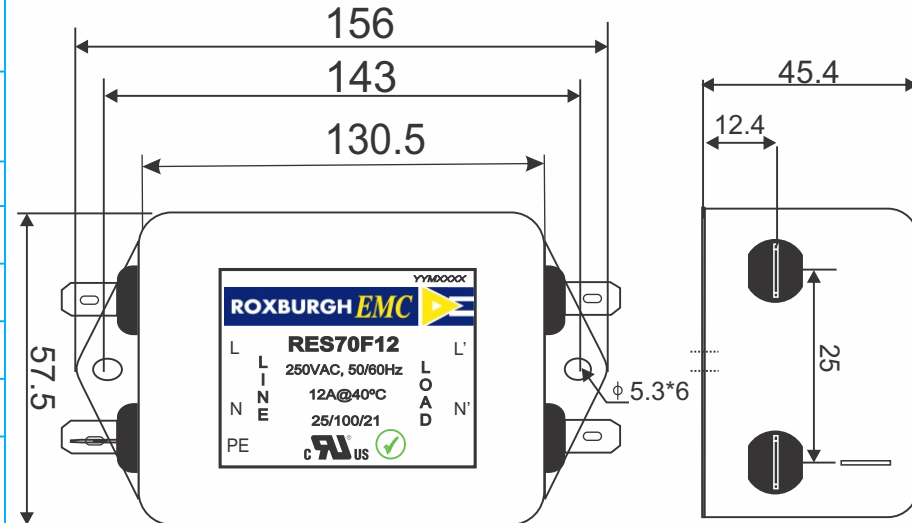

**RES70F12****Rev. 0****CIRCUIT DIAGRAM:****CHARACTERISTICS:**

Rated Voltage:	250VAC max
Rated Current at Ambient:	12A @ 40°C
Operating Frequency:	DC-400HZ
Climatic Class (IEC60068-1):	25/100/21
Temperature Range:	-25°C to +100°C
Over load Current:	1.5 x Rated Ct. for 1 Min
Operational Leakage current : (at 230VAC/50Hz and Total C +/-20%)	0.734 mA max
Worst case Leakage current : ( N interrupted and Total C +/-20%)	<1.101 mA max
DCR @ 25°C (+/-25%) :	50 mΩ
Test Voltage (100%) for 2 sec:-	L-N: 1100VDC
	L-GND: 3000VDC
Ingress Protection:	IP 20
Weight (Approximate):	670 gr

**MECHANICAL DIMENSION (mm):****FILTER PARAMETERS:**

Total Inductance (L-L'+N-N') @10KHz:	6.5mH +50%,-30%
Total Capacitance (L-L/L-N) @1KHz:	2μF +/- 20%
Total Capacitance (L-G/N-G) @1KHz:	9.4nF +/- 20%
Total Resistance (L-L/L-N):	0.22MΩ +/- 10%
Total Resistance (L/N-GND):	

**APPROVALS:**

REACH  
RoHS  
UL



APPROVED  
BY  
AJAY  
Date: 15-04-2014

**Note:**

Housing matl. Fe with Ni Plated  
Fast-On Terminal ( 6.3 x 0.8mm)  
Connections

TOLERANCE: +/-1.0 mm



**ROXBURGH EMC**

Tel:- +44(0) 1724 273200  
email:- [sales@dem-uk.com](mailto:sales@dem-uk.com)  
web :- [www.dem-uk.com/roxburgh](http://www.dem-uk.com/roxburgh)

**ROXBURGH EMC**  
FILTER INSERTION LOSS CHARACTERISTICS  
CISPR 17 - 50 OHM METHOD

**RES70F12**

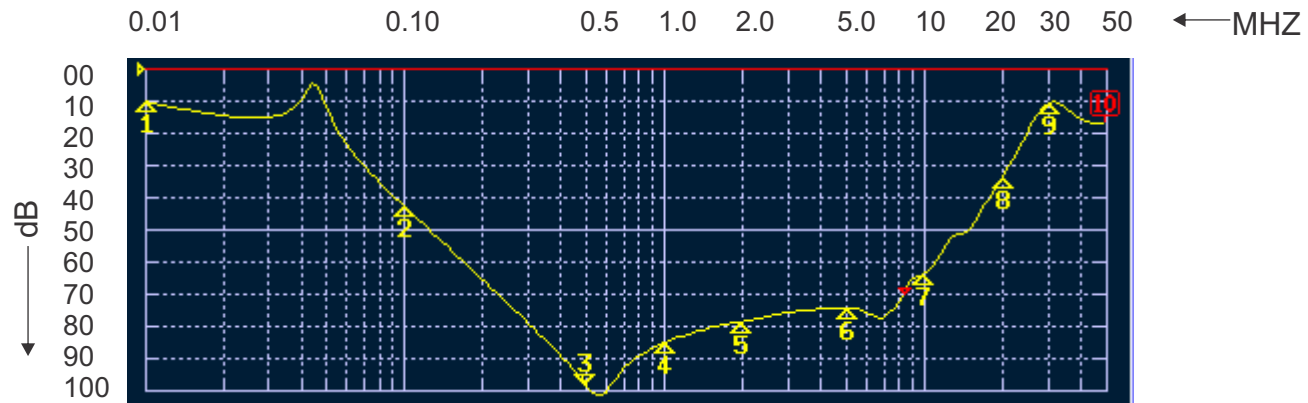

COMMON MODE

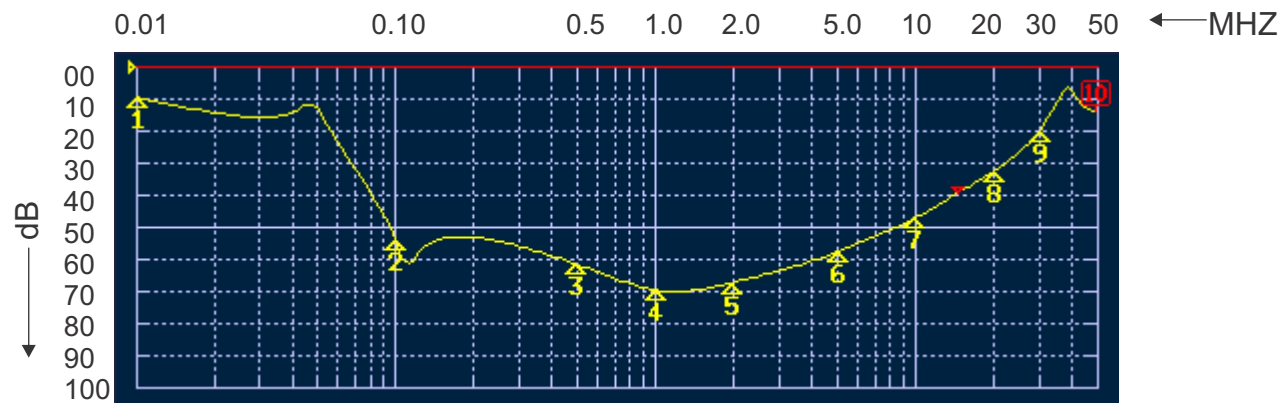

DIFFERENTIAL MODE

