

**Inductive Sensor uprox®**

**Bi5U-EM18H-AP6X-H1141**

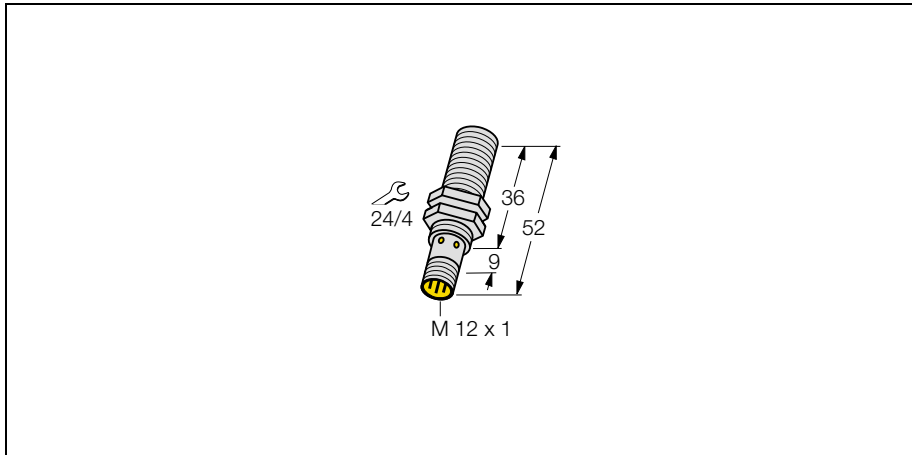

- Threaded barrel, M18x1
- Stainless steel
- Duroplast front cap, high mechanical and thermal resistance
- Factor 1 for all metals
- Degree of protection IP68
- Magnetic field immune
- Increased temperature range
- High switching frequency

<b>Type</b>	Bi5U-EM18H-AP6X-H1141
Ident-No.	1635112
<b>Rated operating distance Sn</b>	5,0 mm
Mounting mode	flush
Hysteresis H	3...15 %
Max. relative temperature drift	≤ 15 % v.E
Min. repeat accuracy	≤ 2 % v.E
Operation temperature	-30...85 °C
<b>Rated operational voltage (DC) U<sub>e</sub></b>	10...30 VDC
Max. ripple	≤ 10 % U <sub>SS</sub>
Rated operational current (DC) I <sub>e</sub>	200 mA
No-load current I <sub>0</sub>	≤ 15,0 mA
Max. OFF-state current	≤ 0,1 mA
Max. switching frequency	≤ 2,5 kHz
Rated insulation voltage	0,5 kV
Output function	normally open, PNP
Short-circuit protection	yes, cyclic
Max. voltage drop at I <sub>e</sub>	≤ 1,8 V
Wire brakage and reverse polarity protection	yes, complete
Degree of protection / protection class	IP 68
<b>Housing style</b>	threaded barrel; EM18H
Housing diameter	18,0 mm
Dimensions	52,0 mm
Housing material	stainless steel; V2A 1.4301
Active face	plastic; Duroplast
Max. fixing torque of coupling nut	≤ 25,0 Nm
Wiring	connector; M12x1 eurocon
Vibration resistance	55 Hz (1 mm)
Shock resistance	30 x g (11 ms)
<b>Switching status indication</b>	LED; yellow

3-wire DC, 10-30VDC  
Normally open, PNP-output  
Connector, M12x1 eurocon

**Wiring diagram**

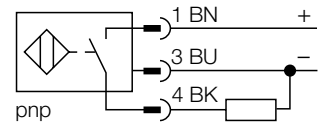

**Function principles**

Inductive sensors serve for wear-free and non contact detection of metal objects. Uprox Factor 1-sensors have considerable advantages because of their patented fer-rite-less 3-coil system. They detect all metals with the same operating distance, are magnetic field immune and have high operating distances.

**Inductive Sensor uprox®**

**Bi5U-EM18H-AP6X-H1141**

**Mounting accessories**

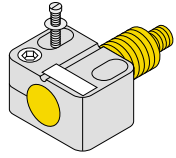
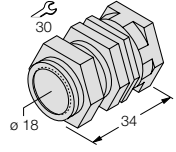
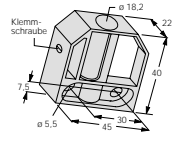
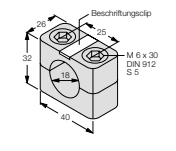
Typ	Ident-No.	Text	Dimension drawing
BST-18B	6947214	Fixing clamps; Material: PA6	
QM-18	6945102	Fixing clamps; Material: chrome-plated brass	
BS18	69471	Fixing clamps; Material: PA66-GF	
BSN18	69472	Fixing clamps; Material: PA66-GF	
SKN/M18	69663	Protective teflon caps; Material PTFE; For use in welding facilities and grinding machines with strong sparking	