

EASY618-...
EASY619-...
EASY620-...
EASY621-...
EASY200-EASY

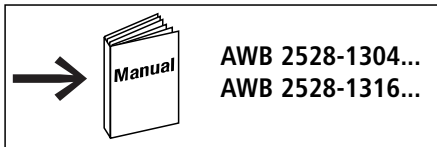

Lebensgefahr durch elektrischen Strom!

Nur Elektrofachkräfte und elektrotechnisch unterwiesene Personen dürfen die im folgenden beschriebenen Arbeiten ausführen. Beachten Sie für die Installation der Geräte die länderspezifischen Vorschriften.

Electric current! Danger to life!

Only skilled or instructed persons may carry out the following operations. The national regulations/specifications must be observed for the installation of the devices.

Tension électrique dangereuse !

Seules les personnes qualifiées et averties doivent exécuter les travaux ci-après. Veuillez respecter les normes de mise en oeuvre spécifiques aux différents pays.

Tensione elettrica: Pericolo di morte!

Solo persone abilitate e qualificate possono eseguire le operazioni di seguito riportate. Per l'installazione degli apparecchi è necessario rispettare le normative specifiche di ciascun paese.

¡Corriente eléctrica! ¡Peligro de muerte!

El trabajo a continuación descrito debe ser realizado por personas cualificadas y advertidas. Para la instalación de los aparatos han de tenerse en cuenta las normativas/especificaciones a nivel local.

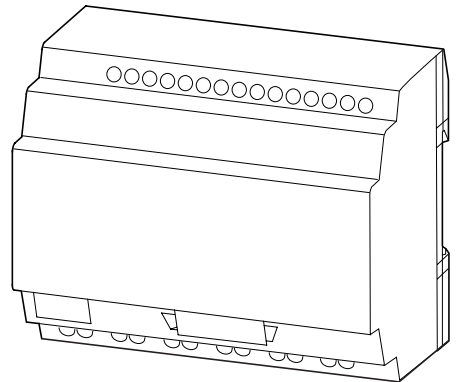
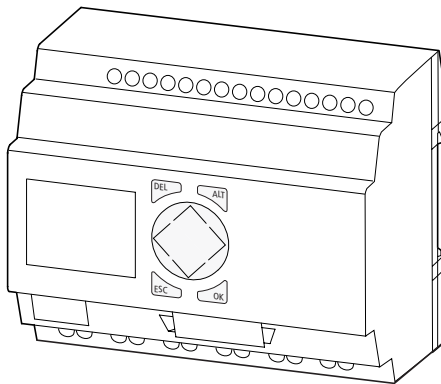

Frontansicht/Front view/Face avant/Vista frontale/Vista de frente

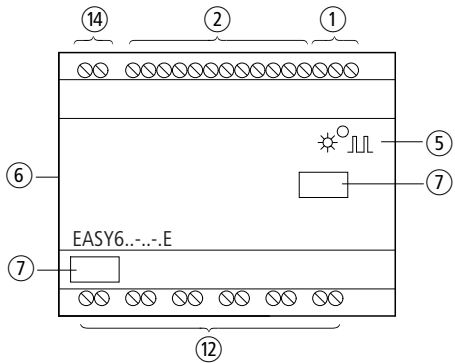
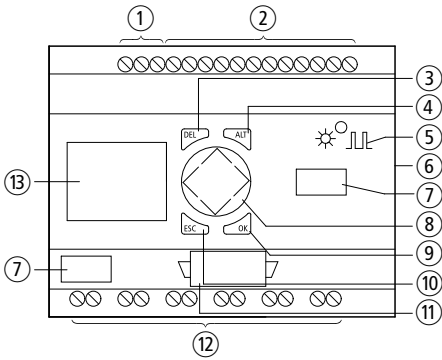

D

- ① Spannungsversorgung
EASY...-DC... 24 V DC
EASY...-AC... 85 bis 264 V AC 50/60 Hz
- ② Eingänge
EASY...-DC... 12 Eingänge 24 V DC
(2 auch als Analog-Eingänge 0 bis 10 V nutzbar)
EASY...-AC... 12 Eingänge 0 bis 264 V AC
- ③ DEL-Taste
Löschen von Kontakten/Relais/
Verbindungen/leerem Strompfad
- ④ ALT-Taste
Verbindungen zeichnen
Umschalter: Kontakt = Schließer oder Öffner
Strompfad einfügen
- ⑤ Power/Run-LED
- ⑥ Zentrale Kopplung
- ⑦ Gerätekenzeichnungsschild
- ⑧ Cursorstasten: rechts, links, oben, unten
Kontakte, Relais, Nummer wählen
P-Taste an: Eingang P1 -> Cursor links
 Eingang P2 -> Cursor oben
 Eingang P3 -> Cursor rechts
 Eingang P4 -> Cursor unten
- ⑨ OK-Taste
Menü weiterschalten, Aktion übernehmen
- ⑩ ESC-Taste
Ein Menü zurück
Menü, Parameter Funktionsrelais verlassen
Verlassen ohne Speichern
- ⑪ Schnittstelle (mit Abdeckung)
Steckplatz für Speicherkarte
Buchse für PC-Schnittstellenkabel
- ⑫ Ausgänge
LCD (falls vorhanden)
- ⑬ Zustandsanzeige der Ein-/Ausgänge
Betriebszustände
Schaltplan
Anzeige der Uhr
- ⑭ Dezentrale Kopplung

GB

- ① Voltage supply
EASY...-DC... 24 V DC
EASY...-AC... 85 to 264 V AC 50/60 Hz
- ② Inputs
EASY...-DC... 12 inputs 24 V DC
(2 can also be used as 0 to 10 V analog inputs)
EASY...-AC... 12 inputs 0 to 264 V AC
- ③ DEL button
Delete contacts/relays/connections/
empty current path
- ④ ALT button
Draw connection
Toggle between make or break contact
Insert current path
- ⑤ Power/Run LED
- ⑥ Central connection
- ⑦ Device label
- ⑧ Cursor buttons: right, left, up, down
Select contacts, relays, numbers
P button on: Input P1 -> Cursor left
 Input P2 -> Cursor up
 Input P3 -> Cursor right
 Input P4 -> Cursor down
- ⑨ OK button
Enter menu, Accept action
- ⑩ ESC button
One menu back
Exit function relay parameter menu
without saving
- ⑪ Interface (with cover)
Slot for memory card
Socket for PC interface cable
- ⑫ Outputs
- ⑬ LCD
I/O status display
Operating states
Circuit diagram
Display of clock
- ⑭ Remote connection

04/00 AWA2528-1837

F

- ① Alimentation
EASY...-DC-... 24 V CC
EASY...-AC-... 85 à 264 V CA 50/60 Hz
- ② Entrées
EASY...-DC-... 12 entrées 24 V CC
(dont 2 utilisables comme entrées analogiques 0 à 10 V)
EASY...-AC-... 12 entrées 0 à 264 V CA
- ③ Bouton DEL
Effacement des objets (contacts, relais, liaison, circuits de courant vides) au niveau de la position du curseur
- ④ Touche ALT
Dessiner les liaisons
Inverseur : contact = contact F ou contact O
Insérer circuit de courant
- ⑤ DEL sous tension/marche
- ⑥ Connecteur pour module d'extension local
- ⑦ Etiquette de repérage de l'appareil
- ⑧ Touches de direction : droite, gauche, haut, bas
Sélectionner opérandes et indices (contacts, relais, numéro) Affectation des touches entrée P :
entrée P1 -> curseur gauche
entrée P2 -> curseur haut
entrée P3 -> curseur droite
entrée P4 -> curseur bas
- ⑨ Bouton OK
Niveau menu, exécuter la fonction
- ⑩ Touche ECHAP
Retour au menu précédent
Quitter le niveau « Entrée du programme »
Quitter sans enregistrer
- ⑪ Interface (avec capot)
Emplacement pour carte mémoire
Connecteur femelle pour câble d'interface PC
- ⑫ Sorties
- ⑬ LCD
- ⑭ Raccordement des modules d'extension décentralisés

I

- ① Tensione di alimentazione
EASY...-DC-... 24 V DC
EASY...-AC-... 85 a 264 V AC 50/60 HZ
- ② Ingressi
EASY...-DC-... 12 ingressi 24 V DC
(2 utilizzabili anche come ingressi analogici 0 a 10 V)
EASY...-AC-... 12 ingressi 0 a 264 V AC
- ③ Tasto DEL
Cancellazione di contatti, relé, collegamenti, vuoti linee vuote
- ④ Tasto ALT
Disegno dei collegamenti
Commutatore: contatto = chiusura/apertura
Inserisci/cancella riga, circuito di corrente
LED Power/Run
- ⑤ Collegamento locale
- ⑦ Targhetta per il nome dell'apparecchio
- ⑧ Tasti cursore, destra, sinistra, su, giù
Selezione contatti, relé, numeri
Tasto P a: lato P1 -> cursore a sinistra
lato P2 -> cursore su
lato P3 -> cursore a destra
lato P4 -> cursore giù
- ⑨ Tasto OK
Menù successivo, conferma azione
- ⑩ Tasto ESC
Menù precedente
Esci dal menù, parametro relé di funzione
Esci senza salvare
- ⑪ Interfaccia (con copertura)
Posizione di inserimento per la scheda di memoria
Connettore femmina per cavo di interfaccia PC
- ⑫ Uscite
- ⑬ LCD
Visualizzazione di stato degli ingressi/uscite
Stati di funzionamento
Schema a contatti
Visualizzazione dell'ora
- ⑭ Collegamento remoto

E

- ① Tensión de alimentación
EASY...-DC-... 24 V DC
EASY...-AC-... 85 a 264 V AC 50/60 Hz
 - ② Entradas
EASY...-DC-... 12 entradas 24 V DC
(2 también pueden utilizarse como entradas analógicas de 0 a 10 V)
EASY...-AC-... 12 entradas 0 a 264 V AC
 - ③ Tecla DEL
Borrar contactos/relés/conexiones/
circuito de corriente en vacío
 - ④ Tecla ALT
Diseñar conexiones
Accionamiento del interruptor basculante (Toggle) entre contacto de apertura ó de cierre
Insertar circuito de corriente
 - ⑤ Cierre/LED de funcionamiento
 - ⑥ Acoplamiento centralizado
 - ⑦ Etiqueta de características del aparato
 - ⑧ Teclas de cursor: derecha, izquierda, arriba, abajo.
Selección de contactos, relés, números
- | | | |
|----------------|------------|------------------|
| Tecla P sobre: | Entrada P1 | Cursor izquierda |
| | Entrada P2 | Cursor arriba |
| | Entrada P3 | Cursor derecha |
| | Entrada P4 | Cursor abajo |
- ⑨ Tecla OK
Entrar menú
Aceptar acción
 - ⑩ Tecla ESC
Un menú hacia atrás
Salir del menú de parámetros del módulo lógico
Salir sin archivar
 - ⑪ Interface (con tapa)
Slot para tarjeta de memoria
Hembrilla para cable de interface a PC
 - ⑫ Salidas
 - ⑬ LCD
Visualizador de estado ABIERTO/CERRADO
Estados operativos
Esquema de circuitos
Display del reloj
 - ⑭ Acoplamiento descentralizado

Standardanschluss, Eingänge/Standard connection, inputs/Raccordement standard, entrées/Collegamento standard, ingressi/Conexión estándar, entradas

EASY6...DC...C.

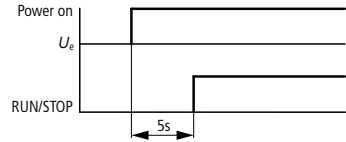
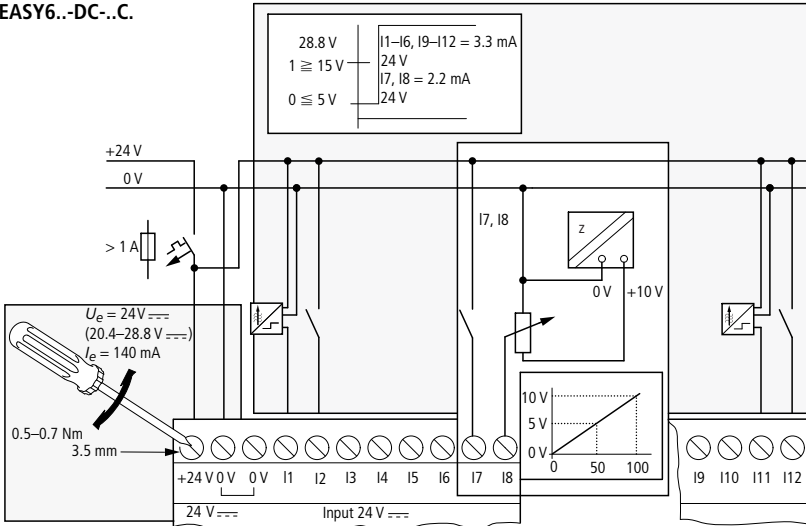

EASY6...DC...E

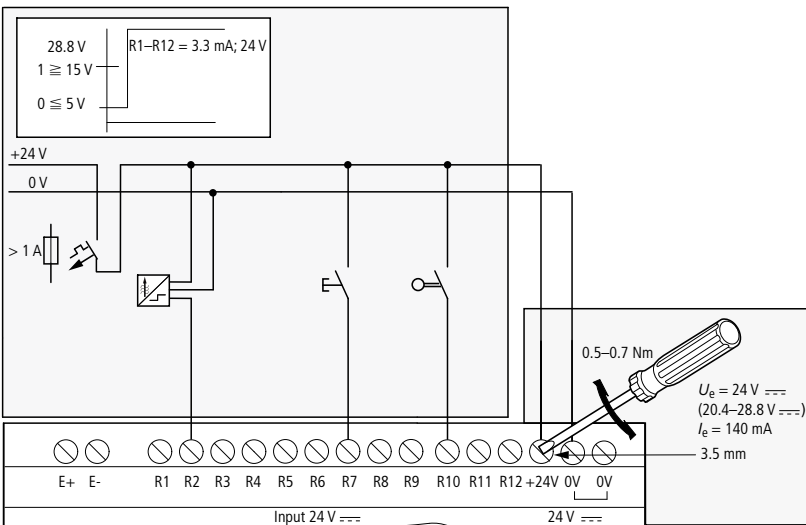

EASY6...AC...C.

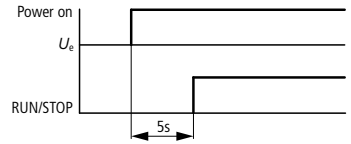
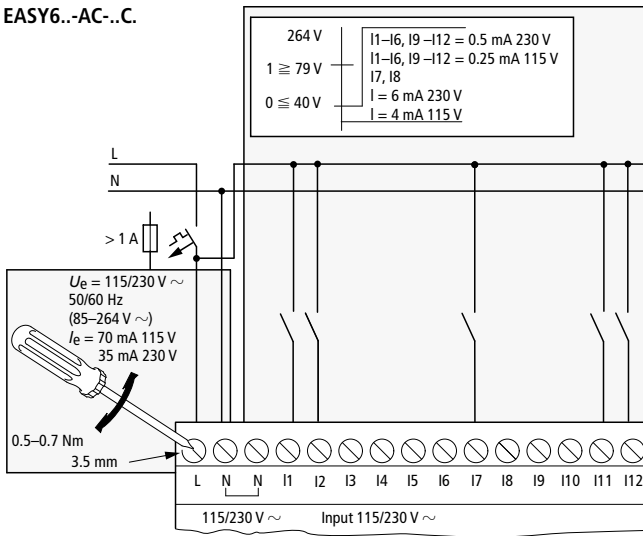

04/00 AWA/2528-1837

EASY6...AC...E

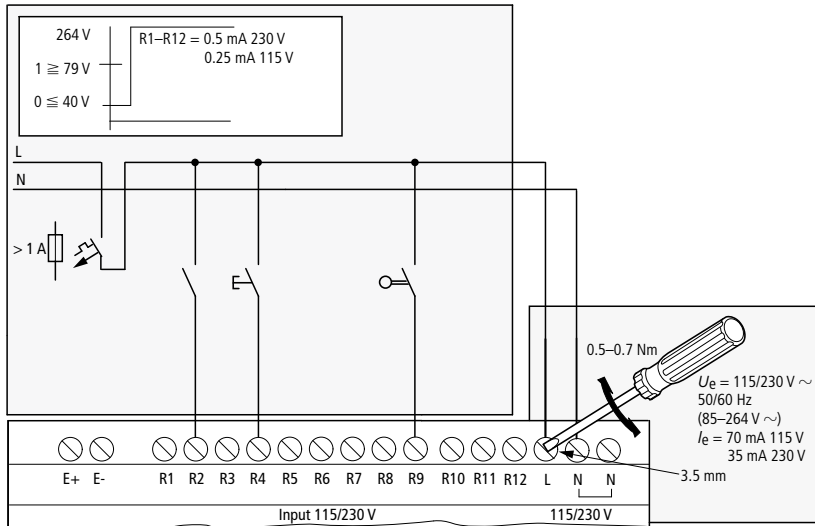

Standardanschluss, Ausgänge/Standard connection, outputs/Raccordement standard, sorties/Collegamento standard, uscite/Conexión estándar, salidas

EASY6...-RC.

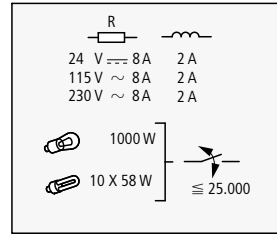
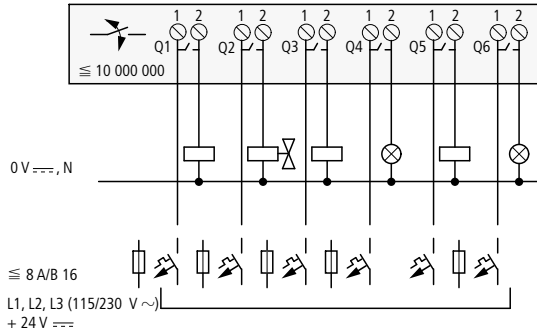

EASY6...-RE

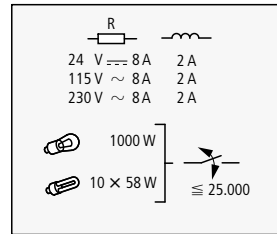
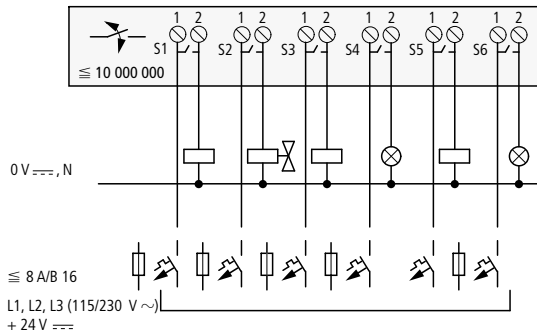

EASY6...-TC..

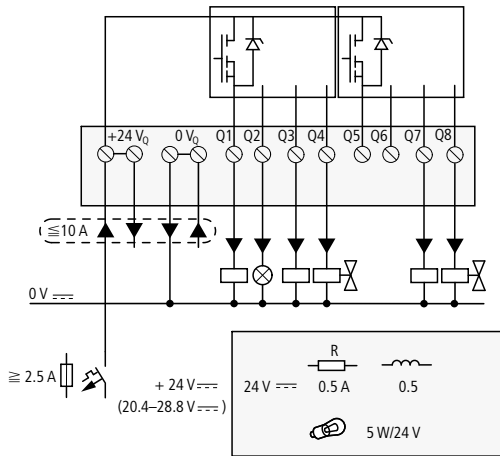

Schutzbeschtaltung
Protective circuit
Circuit de protections
Circuito di protezione
Circuito supresor

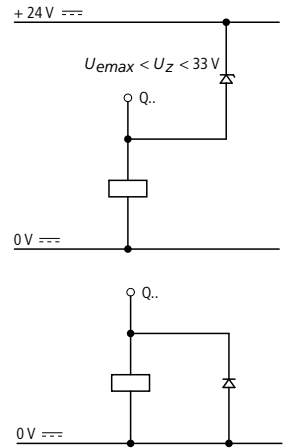

04/00 AWA2528-1837

EASY6...-TE

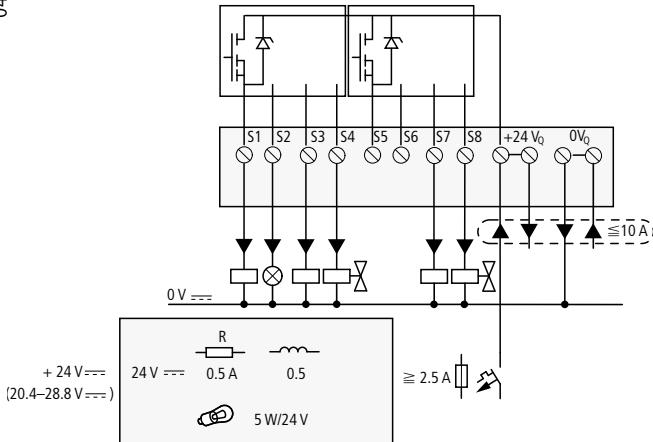

Anschluss/Connecting the/Raccordement/Collegamento/Conexión

Zentrale Erweiterung
 Central expansion
 Extension centralisée
 Espansione Locale
 Ampliación centralizada

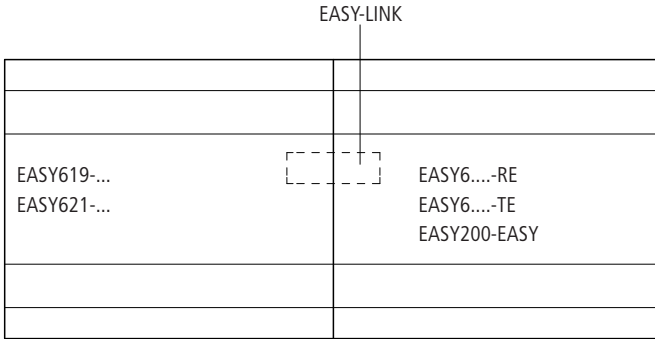

Dezentrale Erweiterung
 Remote expansion
 Extension décentralisée
 Espansione Remota
 Ampliación descentralizada

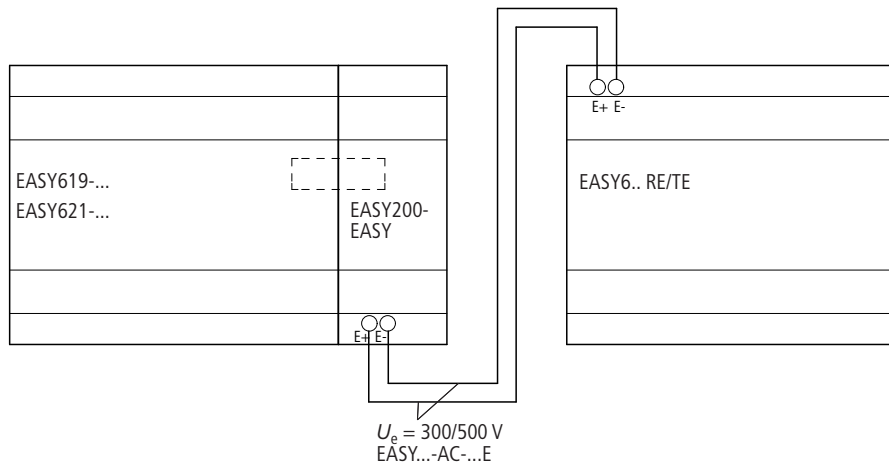

04/00 AWA2528-1837

Zentrale Erweiterung/Central expansion/Extension centralisée/Espansione locale/Ampliación centralizada

Einbau **1** + **2** , Ausbau **3** + **4** ⚡ Geräte müssen spannungsfrei sein!

Fitting **1** + **2** , removing **3** + **4** ⚡ Devices must be de-energized!

Montage **1** + **2** , démontage **3** + **4** ⚡ Assurer la mise hors tension des appareils !

Montaggio **1** + **2** , smontaggio **3** + **4** ⚡ Gli apparecchi non devono essere alimentati!

Montaje **1** + **2** , ampliación **3** + **4** ⚡ Los aparatos deben estar desconectados a tensión!

04/00 AWA2528-1837

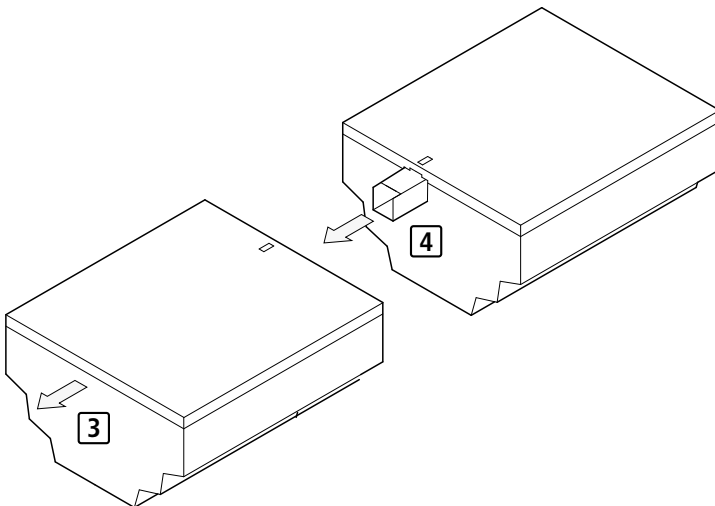
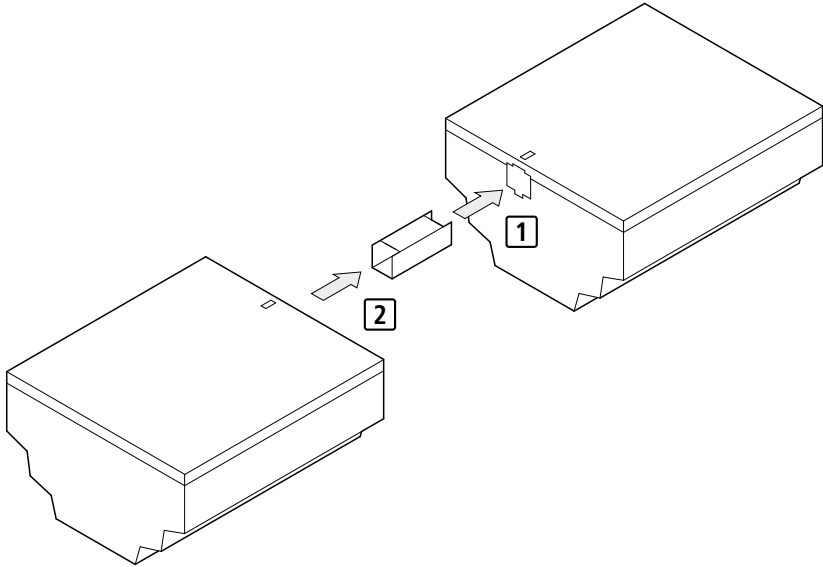

Sprachauswahl bei erster Inbetriebnahme

Language selections for commissioning

Choix de la langue en cas de première mise en service

Scelta della lingua alla prima messa in servizio

Selección de lenguaje en la puesta en marcha

D, GB, F, E, I, P, NL, S, PL, TR

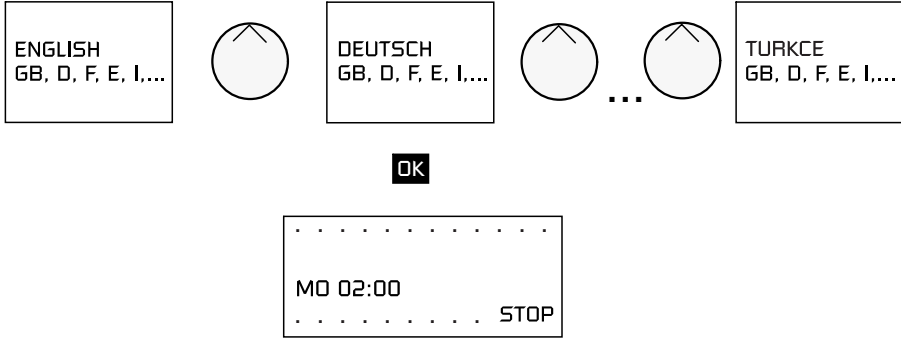

Relais, Kontakte
Relays, contacts
Relais, contacts
Relé, contatti
Relés, contactos

Q	I	T	1 - 16
M	Q	\bar{Q}	1 - 8
	M	\bar{M}	1 - 16
	A	\bar{A}	1 - 8
	\oplus	\ominus	1 - 4
C	C	\bar{C}	1 - 8
T	T	\bar{T}	1 - 8
	P	\bar{P}	1 - 4
D	D	\bar{D}	1 - 8
:	:		1 - 8
	R	\bar{R}	1 - 16
S	S	\bar{S}	1 - 8

04/00 AWA2528-1837

Temperaturbereich:
Temperature range:
Plage de température :
Campo temperatura:
Rango de temperatura:
-25...+55 °C

- LCD-Anzeige im Bereich 0 bis 55 °C lesbar
- Betauung des Gerätes unbedingt verhindern!
- LCD display legible in range 0 to 55 °C
- On no account allow condensation to form on the device!
- Afficheur LCD lisible dans la plage 0 à 55 °C
- Eviter impérativement toute condensation sur l'appareil !
- Visualizzatore LCD leggibile a una temperatura compresa tra 0 a 55 °C
- Impedire assolutamente la formazione di condensa sull'apparecchio!
- El visualizador LCD es legible dentro del rango 0 a 55°C
- No debe producirse condensación en el aparato!

Kurzschlussauswertung
Short-circuit detection
Analyse du court-circuit
Segnale di corto circuito
Detección de cortocircuitos

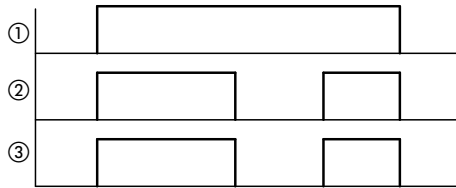

① Kurzschluss, Überlast
 Short-circuit, overload
 Court-circuit, surcharge
 Corto circuito, Sovraccarico
 Cortocircuito, sobrecarga

② Übertemperatur
 Overtemperature
 Echauffement
 Sovratemperatura
 Sobretemperatura

③ Fehlererkennung I15, I16, R15, R16
 Fault detection I15, I16, R15, R16
 Détection de défaut I15, I16, R15, R16
 Riconoscimento dell'errore I15, I16, R15, R16
 Detección de fallo I15, I16, R15, R16

I16 = Q1–Q4

I15 = Q5–Q8

R16 = S1–S4

R15 = S5–S8

Erweiterungsüberwachung I14/I14 expansion monitoring/Surveillance module d'extension I14/Sorveglianza modulo d'estensione I14/Control módulo de ampliación I14

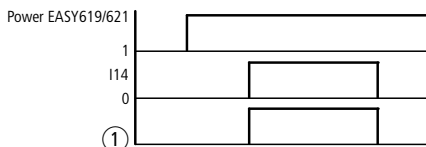

- ① EASY-LINK gestört, Kabelbruch/① EASY-LINK faulty, cable break/① Défaut EASY-LINK, rupture de câble/
 ① EASY-LINK disturbata, rottura cavo/① EASY-LINK erróneo, rotura de cable

Remanenz/Retention/Remanence/Rimanenza/Retención

S, R, J, D1–D8, M13, M14, M15, M16, T7, T8, C5, C6, C7, C8:

Remanent bei Menüanzeige REMANENZ AUS

Retentive with menu display RETENT. OFF (retention off)

Remanents lors de l'affichage REMANENT NON (rémanence désactivée)

Rimanenti nella visualizzazione menù RET. PARO (senza rimanenza)

Remanentes con visualización RIMANEN. OFF (retención desactivada)



Anlauf „RUN“
 “RUN” mode
 Mode « RUN »
 Avviamento con “RUN”
 Modo “RUN”

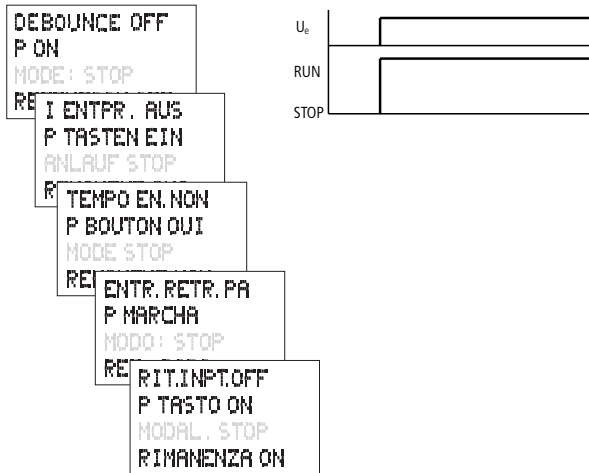

Anlauf im „STOP“
 “STOP” mode
 Mode « STOP »
 Avviamento con “STOP”
 Modo “STOP”

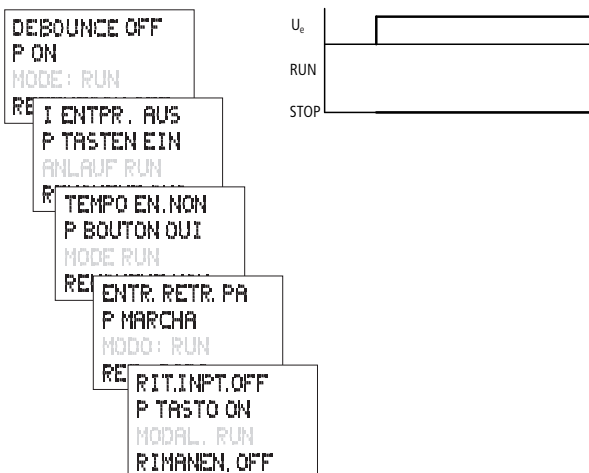

04/00 AWA2528-1837

Schnittstelle EASY-PC-CAB ①/Speichermodul EASY-M-16K ②

EASY-PC-CAB interface ①/EASY-M-16K memory card ②

Interface EASY-PC-CAB ①/carte memoire EASY-M-16K ②

Interfaccia EASY-PC-CAB ①/scheda di memoria EASY-M-16K ②

Interface EASY-PC-CAB ①/tarjeta de memoria EASY-M-16K ②

1

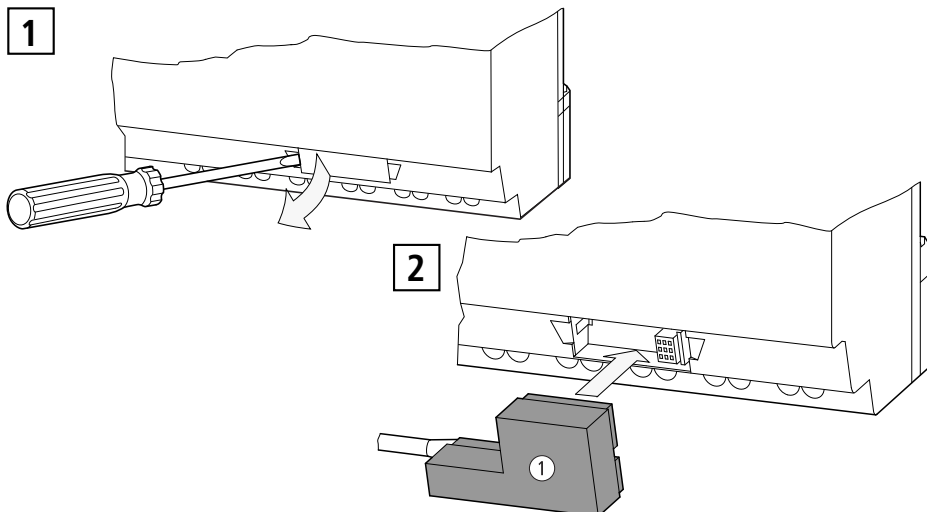

2

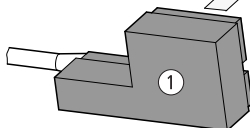

3

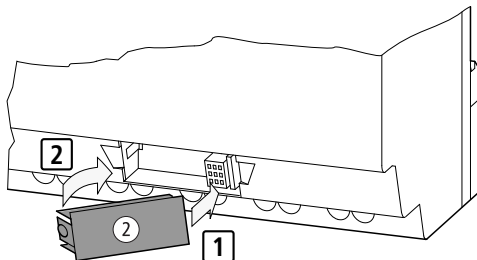

04/00 AWA2528-1837



EASY6..-AC...

Schnittstelle bei Betrieb mit 115/230 V geschlossen halten!

When operating with 115/230 V keep interface closed!

En cas de fonctionnement sous 115/230 V, s'assurer que l'emplacement destiné à la cartouche mémoire et au câble PC soit obturé afin d'éviter tout danger !

Tenere chiusa l'interfaccia per il funzionamento con 115/230 V!

Mantener interface cerrado con accionamiento a 115/230 V!

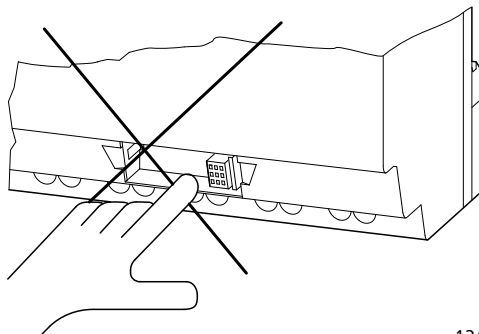

Montage/Fitting/Montaggio/Montaje

auf 35-mm-Hutschiene
on 35 mm top-hat rail
sur profilé-support 35 mm
su guida DIN 35 mm
sobre guía semétrica de 35 mm

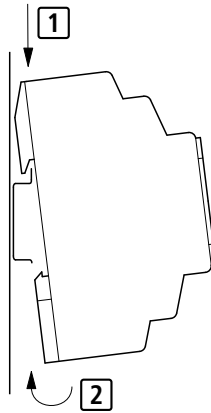

Montage/Fitting/Montaggio/Montaje

auf Montageplatte (waagrecht)
on mounting plate (horizontal)
sur plaque de montage (horizontal)
su piastra di montaggio (orizzontale)
sobre placa de montaje (horizontal)

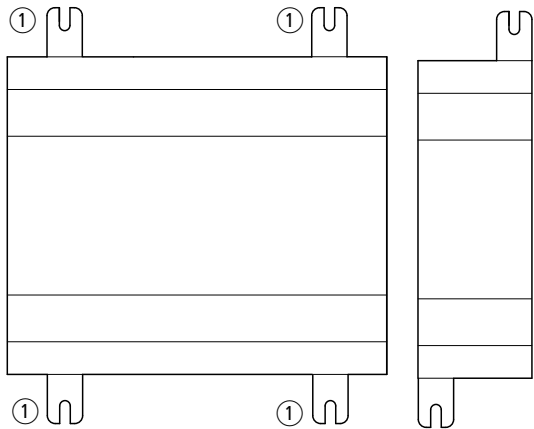
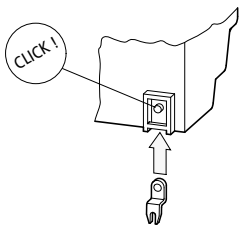

- ① 3 Gerätefüße ausreichend
- ① 3 Sufficient fixing feet
- ① 3 Pattes de fixation sur platine
- ① 3 Piedini di fissaggio
- ① 3 Pie de sujeción adecuado.

04/00 AWA2528-1837

Einbaulage/Mounting position/Position de montage/Montaggio/Posición de montaje

mit Hutschiene (waagrecht und senkrecht)
with top-hat rail (horizontal and vertical)
sur profilé chapeau (horizontale et verticale)
su guida (orizzontale e verticale)
sobre carril (horizontal y vertical)

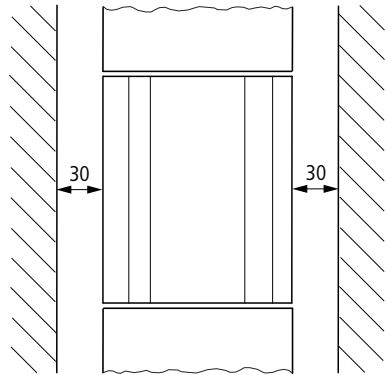
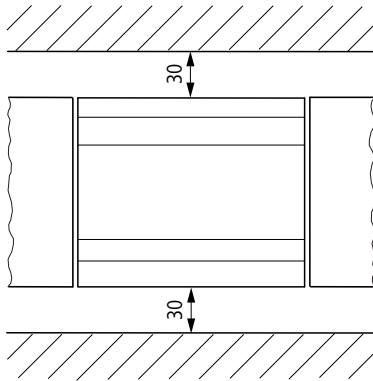

04/00 AWA2528-1837

Abmessungen/Dimension/Dimensions/Dimensioni/Dimensiones [mm]

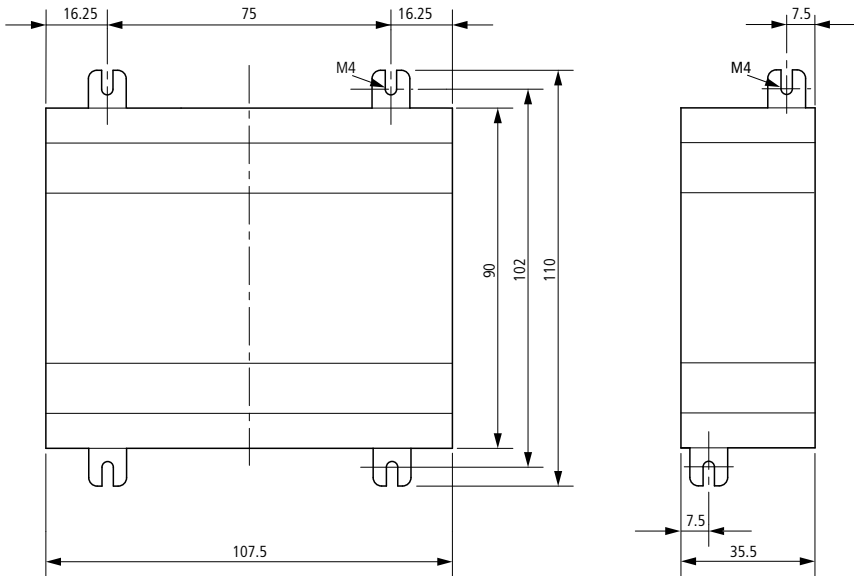
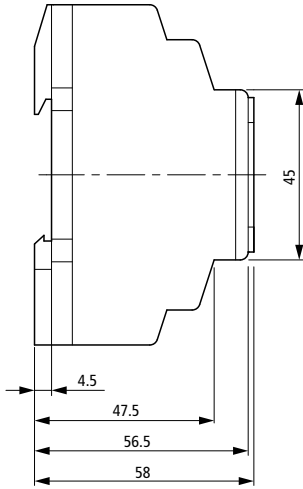

04/00 AWA2528-1837