



PRODUCT DATASHEET

High Bay series

last update 19/11/2013

DETAILS

Product Number	C13489_HB-5X1-WW
Family	High Bay
Type	Lens array
Color	clear
Diameter	123 + 25 mm
Height	9,3 mm
Style	rectang
Optic Material	PMMA
Holder Material	
Fastening	screw, pin, glue
Status	ready
ROHS Compliant	Yes
Date Updated	18/10/2013



OPTICAL PROPERTIES

LED	Viewing Angle	Light Beam	Efficiency	cd/lm	Connector
XM-L	sim: 80	Very Wide	-	sim: 0.000	-
XM-L2	72 deg	Very Wide	87 %	0.700	-

D

C

B

A

4

4

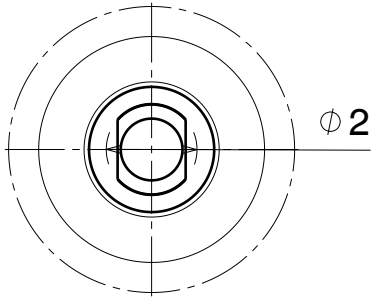

Detail A

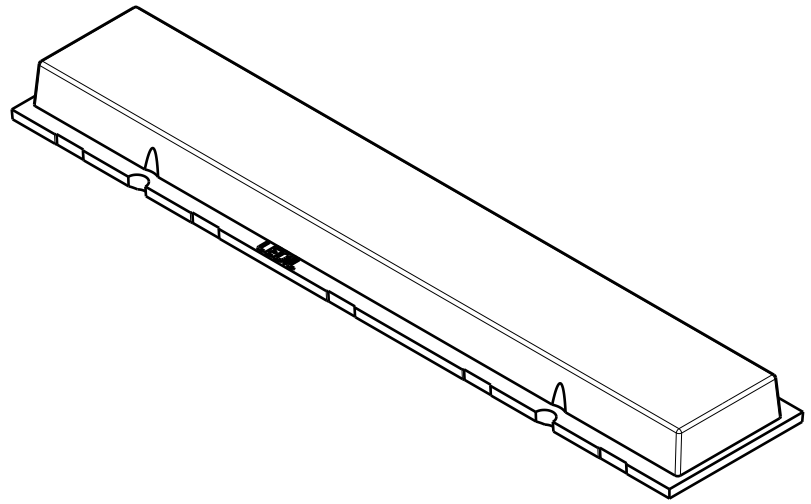

Isometric view

3

3

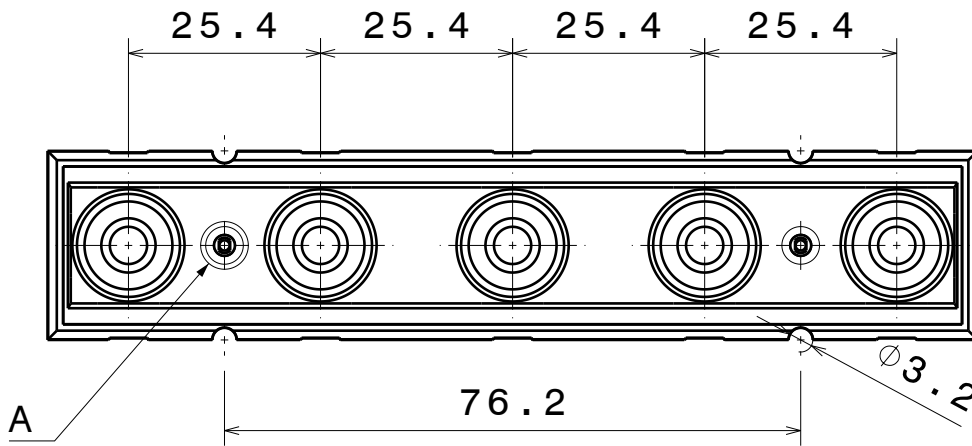

Bottom view

2

2

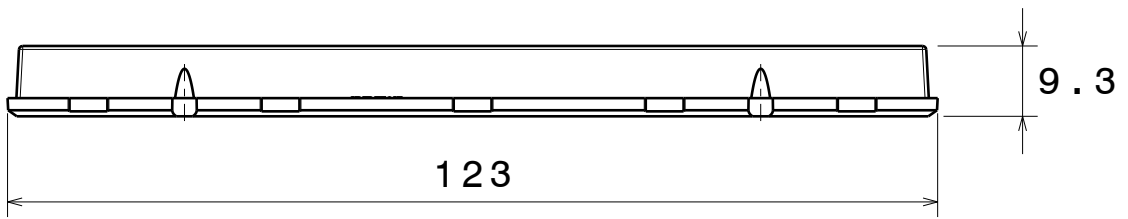

Front view

Tolerances if not otherwise shown
 According to DIN ISO 2768-1
 Linear measures:
 Up to 30mm class M, otherwise class C.
 According to DIN ISO 2768-2
 Form and position: class L

LEDiL Ledil Oy
 Salorankatu 10
 FIN 24240 SALO
 Finland

THIRD ANGLE PROJECTION:

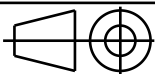

DRAWING TITLE

HB-5X1-WW Datasheet

This drawing is the property
 of LEDiL Oy. It may not be
 reproduced, copied or
 communicated without a written
 agreement with LEDiL Oy."

SIZE	PART NUMBER
A4	-

SCALE	1:1	WEIGHT	-	SHEET	1/1
-------	-----	--------	---	-------	-----

D

A

1

Luminaire: LEDil Oy C13489_HB-5x1-WW_(XM-L2) Efficiency=87%
Lamps: 1 x Cree XM-L2 (XMLBWT-0-7B4-T30-0L-0001) 449lm @ 250mA CCT=3200K P=3.5W I=250mA

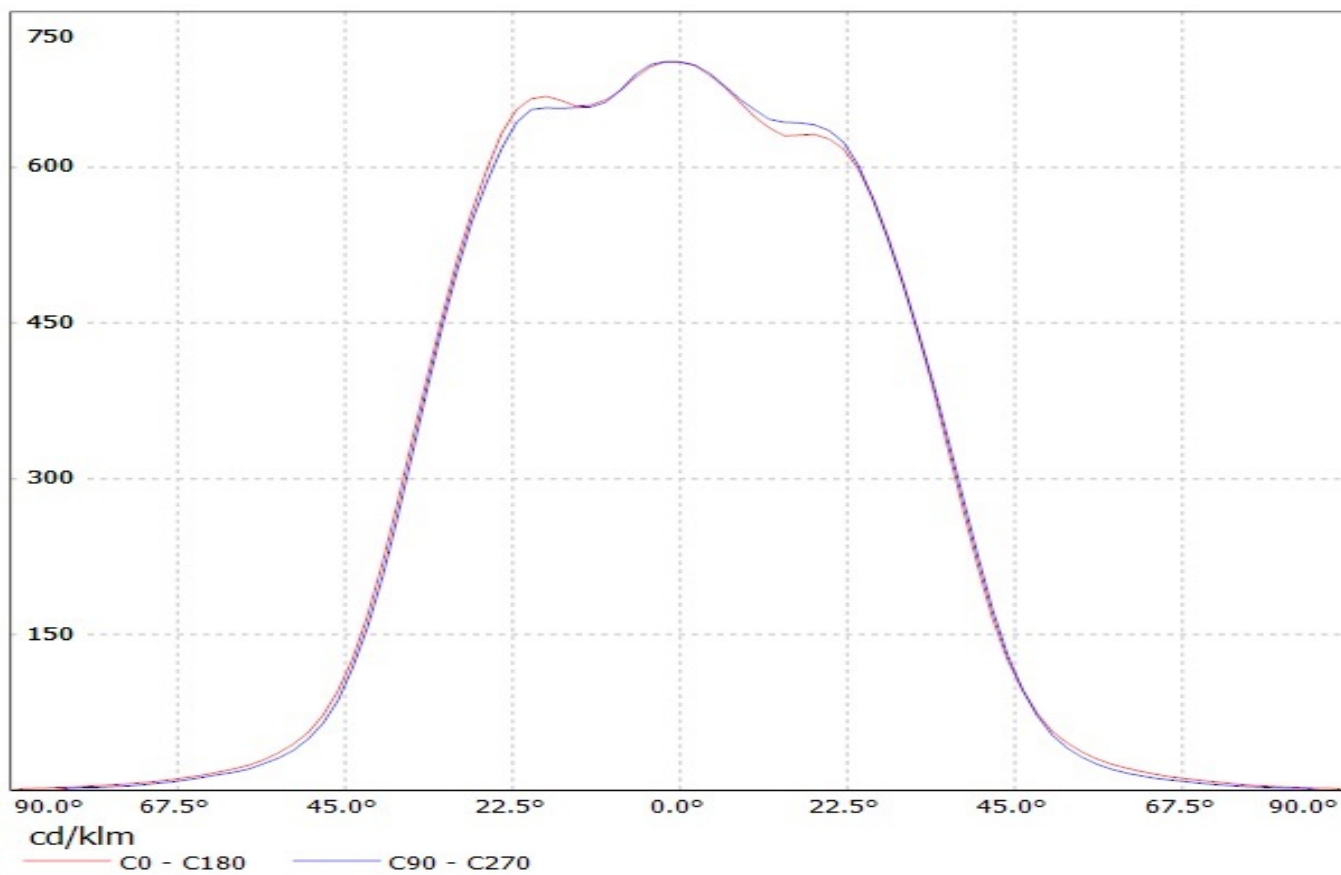

Luminaire: LEDil Oy C13489_HB-5x1-WW_(XM-L2) Efficiency=87%

Lamps: 1 x Cree XM-L2 (XMLBWT-0-7B4-T30-0L-0001) 449lm @ 250mA CCT=3200K P=3.5W I=250mA

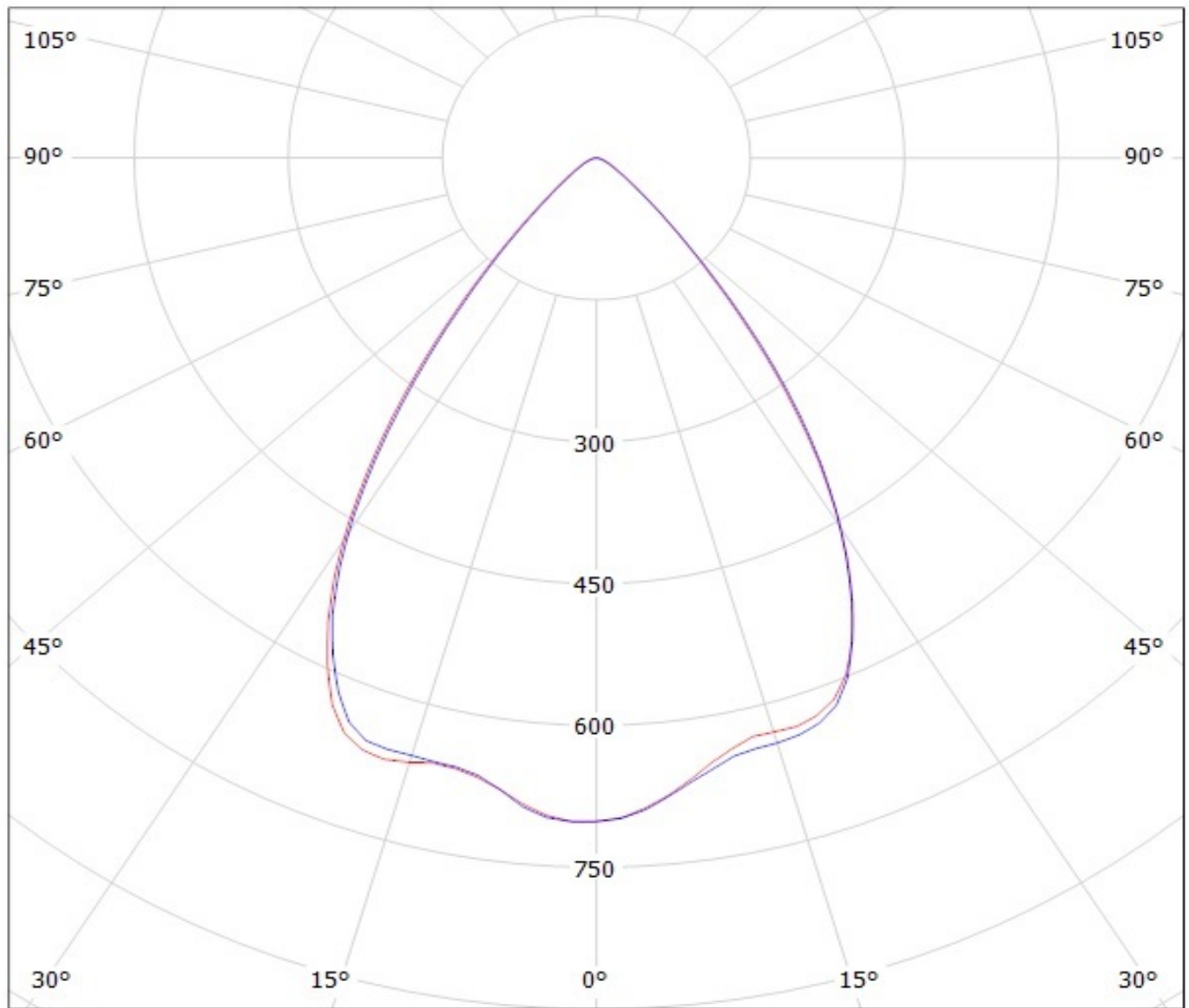

cd/klm

— C0 - C180

— C90 - C270

NOTE: The typical divergence will be changed by different color, chip size and chip position tolerance. The typical total divergence is the full angle measured where the luminous intensity is half of the peak value.