

**DICKSON**

# KT6

## Temperature Chart Recorder

### Contents:

- Product Specifications
- Getting Started / Installation
- Dip Switch Setup
- Charts & Accessories
- Calibration
- Troubleshooting, Warranty / Factory Service & Returns

**DICKSON**

930 South Westwood Avenue • Addison, Illinois 60101

Phone: (630) 543-3747 • E-mail: DicksonCSR@dicksondata.com

Rev. 10/07

# Product Specifications

<b>User Selectable Temperature Ranges</b>	8 User Selectable Temperature Ranges: 0 to -100°F/C, 0 to -50°F/C, -50 to +50°F/C, 0 to +50°F/C, 50 to 100°F/C, 0 to 100°F/C, 0 to 250°F/C, 0 to 500°F (CHARTS SOLD SEPARATELY)
<b>Remote Temperature Accuracy</b>	±.5% of chart range and ±1.8°F (±1°C) Recorder Only
<b>Remote Sensor</b>	Standard 4 ft.K-Thermocouple Beadwire Probe with Mini Connector (other K-TC probes available - see Accessories)
<b>Ambient Operating Conditions</b>	Recorder Only: +32 to +122°F (0 to +50°C) 0 to 95% (non-condensing) Probe Only: -300 to 2000°F (-184 to 1093°C)
<b>Power Source</b>	120V 50/60Hz AC adapter
<b>Power Cord</b>	6' (2 meters)
<b>Power Status Indicator</b>	LED Indicator
<b>Battery Backup</b>	9V battery backup powers unit for up to 3 days
<b>Battery Life (Avg)</b>	72 Hours (Backup Only)
<b>Keypad Functions</b>	Power On/Off, Pen Home, Alarm
<b>Display Type (KT622/23/25)</b>	LCD, 3.5 digit, 3.3V
<b>Display Dimensions (KT622/23/25)</b>	.59" x 1.18" (15mm x 30mm)
<b>Remote Probe Dimensions</b>	K-type bead wire with mini connector; Cable Length: 4' (121cm); extension cables available
<b>Chart Size (Diameter)</b>	6"
<b>Recording Times</b>	24-Hour/7-Day
<b>Response Time</b>	30 Seconds at 63% of full scale
<b>Resolution</b>	0.1° resolution -9.9° to 199.9°; 1° resolution above 199° and below -9.9°
<b>Alarm (KT623/25)</b>	Audio/Visual on High/Low Temp Limits
<b>Relay Type</b>	SPST, 24VDC, 0.5A, NO/NC - Relay does not function while unit is on battery power.
<b>Relay Connection</b>	Spade Lugs, Male 0.25" - One Relay per Channel
<b>Enclosure</b>	Rugged Black ABS Case, Polycarbonate Door, Aluminum Dial
<b>Dimensions (Inches/cm)</b>	7.56" x 7.56" x 3.25" 19.2cm x 19.2cm x 8.3cm
<b>Weight</b>	2.16 lbs 979.7g
<b>IP Rating</b>	IP21

**DICKSON**

Product Specifications & Applications

Quick Start/ Operating Instructions

Charts & Accessories

Calibrations/ Troubleshooting & Warranty

Spanish

French

German

Italian

# Quick Start

1. Your recorder has been preset to operate using the most popular settings.  
Recording Time: 7 day  
Temperature Range: 0 to +100°F  
To change the range and recording time, please reference Dip Switch Set-Up in this manual.
2. Remove the protective pen cap.
3. Insert 9V battery and plug in AC adapter. (see figure 3) (Unit will power on)
4. The instrument will move pen to the appropriate readings.
5. Install the chart that matches the Dip Switch settings you have selected.
  - a. Press the PEN HOME key to move the pen to the outside of the chart. The pen is automatically raised off the chart.
  - b. Remove the old chart, place the new chart on the Chart Hub – being certain that the edge of the chart slides under the Chart Guide Clips located at the outside of the chart.
6. Set the appropriate time. There are two ways to adjust the chart and set the appropriate time:
  - a. Set the chart time manually by inserting a coin into the groove in the chart hub and turning clockwise until the correct hour (and day if applicable) on the chart is referenced to the timing arrow (just to the right of the pen tip on the dial).
  - b. (This feature should be used for fine adjustments only) To adjust the chart time, press and hold ADJUST-UP and ADJUST-DOWN buttons located on the back of the unit next to the dip switch (see figure 3). The green LED will blink rapidly for about five seconds, then the LED will remain solid green. While in this state ADJUST-UP button will move the chart backward (counter clockwise) and ADJUST-DOWN button will move the chart forward (clockwise). Rotate the chart until the correct hour (and day if applicable) on the chart is referenced to the timing arrow. Once you have set your chart, press the PEN HOME button to exit Chart Adjust Mode. The unit will take one minute to exit Chart Adjust Mode once PEN HOME is pressed.
7. Press PEN HOME to move the pen back onto the chart.
8. Place the KT6 recorder on a flat vibration-free surface. Be sure it is in a vertical position and level. For best performance and longevity, the location should be a clean environment, free from dust and corrosive fumes. Do not exceed temperature specifications.

Wall Mount: Keyhole slots are provided on the KT6 recorder for wall mounting.

## Display Symbols (KT622/623/25)

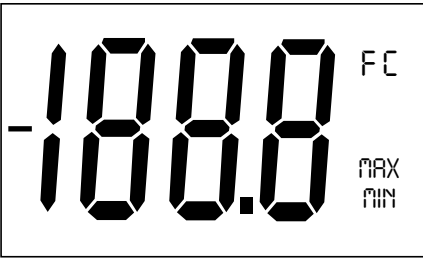

Figure 1

## Button Operations

### ON/OFF

The On/Off key turns the unit on and off.

### PEN HOME

If the pen is located on the outside edge of the chart, press the PEN HOME to move pen to recording position. If the pen is located on the chart, press the PEN HOME key to move the pen to the outside edge of the chart.

**Figure 2**  
KT623/25

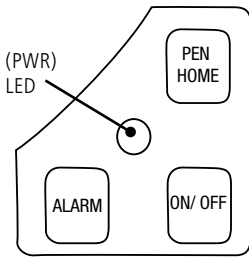

KT621/22

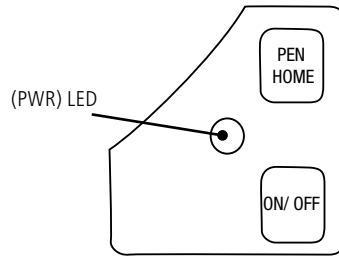

## PEN HOME

If the pen(s) are located on the outside edge of the chart, press the PEN HOME to move pen(s) to recording position. If the pen(s) are located on the chart, press the PEN HOME key to move the pen(s) to the outside edge of the chart.

## ALARM – (KT623/25)

1. To set the alarm, make sure unit is on and press and hold the ALARM button. The LED will blink rapidly for about five seconds, then the LED will turn solid green. Release the ALARM button and the LED will turn solid red. At this point the display will show the following: ON or OFF.
2. Pressing either the ADJUST-UP or ADJUST-DOWN buttons, located on the back of the unit next to the dip switch, will toggle the alarm on or off.
3. Pressing PEN HOME will scroll to the next alarm option. The options are as follows:
  - a. alarm on or off
  - b. pen 1 alarm min
  - c. pen 1 alarm max
4. In order to set pen alarm minimums and maximums, pressing ADJUST-UP will increase the alarm value, and pressing ADJUST-DOWN will decrease the alarm value. There is acceleration if the ADJUST-UP button is held down. Repetitively pressing the PEN HOME button will scroll through the five options until the alarm button is pressed to exit from alarm adjust. Each press of the PEN HOME or ALARM button will store the new settings. The unit will take one minute to exit Alarm Set Mode once the ALARM button is pressed.
5. If the alarm is triggered, the LED will show as solid red and the alarm will sound. Press the ALARM button to silence Audible Alarm.

## Alarm Relays

The SPST 24V 500mA relay contacts are normally open and will close on alarm conditions when the alarms are enabled. Relay contacts are always functional when the alarm is enabled. The relay will close only during minimum and maximum alarm conditions.

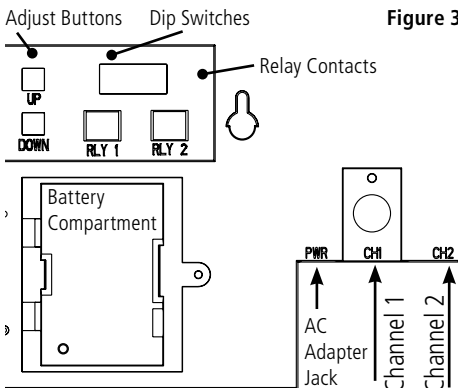

**Figure 3**

# Dip Switch Set-Up

To set-up the KT6 recorder for your specific application, you might need to change some of the Dip Switches. The Dip Switches are located on the back of the unit (figure 3). Use a pen or small screw driver to flip the switches. **Remember to install correct chart to match corresponding**

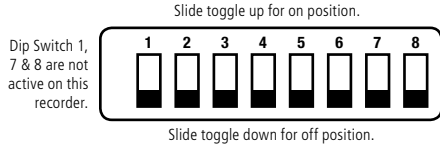

## Dip Switches for ranges

DICKSON KT6 Dip Switch Settings:						
Up = On; Down = Off #25202						
Switches 2-6	For Model	2	3	4	5	6
7 Day	All Models	D				
24 Hour	All Models	U				
Fahrenheit	All Models		D			
Celsius	All Models		U			
0 to +100°F/C	All Models			D	D	D
-50 to 0°F/C	All Models			D	D	U
-100 to 0°F/C	All Models			D	U	U
0 to +50°F/C	All Models			D	U	D
+50 to +100°F/C	All Models			U	U	U
0 to +500°F	All Models			U	U	D
0 to +250°F/C	All Models			U	D	U
-50 to +50°F/C	All Models			U	D	D

Remember to install the correct chart for your range  
**Dickson** - Addison, IL [www.dicksondata.com](http://www.dicksondata.com)

## Temperature Range

KT6 dip switches for ranges

0 to +100°F/C	#4 down #5 down #6 down
-50 to 0°F/C	#4 down #5 down #6 up
-100 to 0°F	#4 down #5 up #6 up
-50 to +50°F/C	#4 up #5 down #6 down
0 to +50°F/C	#4 down #5 up #6 down
+50 to +100°F/C	#4 up #5 up #6 up
0 to +500°F	#4 up #5 up #6 down
0 to +250°F/C	#4 up #5 down #6 up

## Recording Time

The KT6 recorder has two different recording time options

24 hour	#2 up
7 day	#2 down

## °F/C

You can record in °F or °C with the KT6 by using dip switch #3.

°F	#3 down
°C	#3 up

## Charts (for current pricing go to [www.dicksondata.com](http://www.dicksondata.com) or call 1-800-323-2448)

Temperature Range	24 hour Charts	7 day Charts
-50 to +50°F/C	C652	C651
0 to ±50°F/C	C654	C653
50 to +100°F/C	C656	C655
0 to ±100°F/C	C658	C657
0 to +250°F/C	C660	C659
0 to +500°F	C662	C661

## Accessories (for current pricing go to [www.dicksondata.com](http://www.dicksondata.com) or call 1-800-323-2448)

Description	Order Number
NIST Traceable Calibration 3-pt. (new unit)	N300
NIST Traceable Calibration 1-pt. (new unit)	N100
A2LA Accredited Calibration 3-pt. (new unit)	N400
Pens (6 red)	P222
Universal International AC Adapter	R065

## Calibration

Your instrument was carefully tested and calibrated before being shipped from the factory. For greatest accuracy, we recommend factory re-calibration every 6-12 months. Call customer service at (630) 543-3747. If you wish to do calibration yourself, follow these procedures.

1. To activate calibration mode, turn the unit on and press and hold both the On/Off button and the Adjust-Up button (making sure to press the Adjust-Up button first so the unit will not turn off). The led will blink in amber rapidly for about five seconds, and turn solid green. Release the On/Off button and the Adjust-Up button, the led will then blink amber at which point only the pen being adjusted will show on the display.
2. To raise the unit of measurement, press the Adjust-Down button. To lower the unit of measurement, press the Adjust-Up button. Pen home switches between the red and blue pens on a two pen unit and stores the current adjustment value.
3. When calibration is complete, press the On/Off button. Calibration is stored in memory even after you turn the unit off. User calibration information will not be lost if AC power fails.
4. Note: After two hours, if no buttons are pressed, the unit will time out of user calibration and resume normal operation. The user calibration is stored separately from the factory calibration. If you wish to cancel out your user calibration, simply enter calibration mode and toggle through the steps without adjusting displayed readings. Exit by pressing the On/Off button. You have now restored factory calibration.

**Note:** It is recommended that you use a controlled chamber when calibrating temperature and humidity. Calibrating in an open room is not recommended as humidity can vary greatly within a very small area.

# Calibration Services - New Units

**N100 - NIST Traceable Calibration 1-Point:** Includes documentation to one Dickson pre-selected point on new units only.

**N300 - NIST Traceable Calibration 3-Point:** Includes documentation of three Dickson pre-selected points (a high, medium, and low) on new units only.

**N400 - Deluxe A2LA Accredited NIST Traceable Calibration 3-Point:** ISO Guide 25/A2LA Documentation of 3 pre-selected points of as found data before and after calibration for Dickson temperature and/or humidity instrumentation on new units only.

**N995 - NIST User Selected Temperature Points:** Documentation of one customer specified point. Should be selected in addition to one of the above calibration options.

## The Importance and Benefits of Regular Calibrations

Once you begin to use your precision Dickson instrumentation, regular calibrations are necessary to ensure accurate readings.

The following Calibration Services are available:

**N150 - NIST Traceable Calibration 1-Point:** Includes documentation to one Dickson pre-selected point after re-calibration.

**N350 - NIST Traceable Calibration 3-Point:** Includes documentation of three Dickson pre-selected points (a high, medium, and low) after re-calibration.

**N450 - Deluxe A2LA Accredited NIST Traceable Calibration 3-Point:** ISO Guide 25/A2LA Documentation of 3 pre-selected points of as found data before and after calibration for Dickson temperature and/or humidity instrumentation.

**N995 - NIST User Selected Temperature Points:** Documentation of one customer specified point. Should be selected in addition to one of the above calibration options.

### Why should I recalibrate my instrumentation?

Over time dirt, dust and normal handling can throw your precision instrumentation out of calibration. Regular calibrations ensure that you receive the most accurate readings possible.

### How often should I recalibrate my instrumentation?

Depending on the environment your instrument is used in and how often it is handled you will want to recalibrate your instrument every 6 to 12 months. Instruments in environments where there are extreme temperatures, wide temperature ranges, humidity or pressure variations, high condensation, dirt, dust and other debris will require calibration at least every 6 months. Instruments that are frequently moved or in locations with heavy machinery that cause vibrations should also be calibrated at least every 6 months.

### Why should I return my instrument to Dickson for calibration?

Dickson calibrates your instrument at the factory using proprietary production/calibration software that guarantees proper calibration.

### Our Capabilities

Dickson is the first manufacturer of humidity and temperature instrumentation to receive A2LA accreditation. We are also NIST Traceable; our procedures conform to MIS-STD-45662A, ANSI/NCSL 2540-1-1994, ISO/IEC Guide 25 and ISO10012. We are experts in the manufacture and calibration of humidity and temperature instruments.

**Fast Service:** Our turnaround time is 3 days or less so you receive not only expert service but fast service as well.

**Easy:** We make it easy for you! No phone calls for Return Authorization Numbers are required. We remind you when your instrument is due for calibration. You simply send in the completed Calibration

Order Form with your unit for calibration with freight prepaid to Dickson.

# Troubleshooting

For troubleshooting information, click [here](#) for the technical support page.

## Warranty

Dickson warrants that the products it sells will be free from defects in material and workmanship under normal use and service for a period of twelve months after delivery. In the event of a claim under this warranty, the product or part must be returned to the factory for repair or replacement (shipping pre-paid) with a Return Authorization Number (see Return Information above). It will be repaired at Dickson's option without charge. This warranty DOES NOT cover routine calibration, pen, chart and battery replacement. The foregoing warranty and remedy are exclusive and in lieu of all other warranties either expressed or implied. Dickson shall not be liable for consequential or incidental damages resulting from failure or malfunction of its products. Dickson makes no warranty for products not manufactured by it or for any products modified by buyer, or subject to misuse or neglect.

## Factory Service & Returns

Contact the factory (630-543-3747) for a Return Authorization (RA) Number before returning any instrument. The model number, serial number and a purchase order number will be requested before an RA number is issued.

- Carefully repack the instrument, label the outside of the box with the RA# and return the instrument (freight pre-paid) to Dickson.
- All instruments that do not have the RA# clearly marked on the outside of the box will be refused. When returning instruments for credit, please include all accessories in shipment.
- Calibration/Freight charges are non-refundable.

NOTE: Dickson shall not be liable for consequential or incidental damages resulting from failure or malfunction of its products.

## Customer Satisfaction

Dickson takes pride in providing you, the customer, with the highest quality instrumentation. We welcome the opportunity to help you in any way possible. Whether it be a question or a new idea in documentation, the Dickson Company would like to hear your response. Please call our Customer Service Department at 1-800-323-2448 or (630) 543-3747 (in Illinois).

## Software Return Policy

IMPORTANT-Read your Software License Agreement carefully before installing software. Dickson will accept returns for replacement of defective disks and CDs only.

# DICKSON KT621/622/623/625

## Registrador con teledetección de temperatura

**DICKSON**Product  
Specifications &  
ApplicationsQuick Start/  
Operating  
InstructionsCharts &  
AccessoriesCalibrations/  
Troubleshooting  
& Warranty

Spanish

French

German

Italian

### Arranque rápido

1. El registrador ha sido preajustado para operar con los parámetros de mayor aceptación.  
Tiempo de registro: 7 día  
Rango: de 0 a 100°F  
Para cambiar el rango y el tiempo de registro, consulte la referencia en este manual sobre la instalación de interruptores Dip.
2. Quite las tapas protectoras de los estiletes.
3. Inserte pila de 9V y conecte el adaptador de CA. (Vea la figura 3)
4. El instrumento mueve los estiletes hacia las lecturas apropiadas
5. Instale el gráfico que coincida con los ajustes del interruptor Dip que ha seleccionado.
  - a. Pulse la tecla PEN HOME para mover el estilete hacia la extremidad del gráfico. El estilete se eleva automáticamente sobre el gráfico.
  - b. Quite el gráfico usado y coloque uno nuevo en el Concentrador de Gráficos – comprobando que el borde del gráfico se deslice por debajo de las Presillas de Guía de Gráficos situadas en la extremidad del gráfico.
6. Establezca el tiempo adecuado. Hay dos maneras de ajustar el gráfico y establecer el tiempo adecuado:
  - a. Establezca el tiempo manualmente insertando una moneda en la ranura del concentrador de gráficos y girándola en el sentido de las agujas del reloj hasta que la hora correcta (y el día, si corresponde) en el gráfico haga referencia a la flecha temporizadora (exactamente a la derecha de la punta del estilete en el cuadrante).
  - b. (Esta característica sólo debe utilizarse para ajustes finos) Para ajustar el tiempo del gráfico, pulse y mantenga apretados los botones ADJUST-UP y ADJUST-DOWN situados en la parte posterior de la unidad junto al interruptor Dip (vea la figure 3). El LED verde parpadea rápidamente alrededor de cinco segundos y luego pasa a ser de color verde entero. En este estado, el botón ADJUST-UP mueve el gráfico hacia delante (en el sentido de las agujas del reloj) y el botón ADJUST-DOWN lo hace hacia atrás (en sentido contrario al de las agujas del reloj). Gire el gráfico hasta que la hora correcta (y el día, si corresponde) en el gráfico haga referencia a la flecha temporizadora. Una vez ajustado el gráfico, pulse el botón PEN HOME para salir del Modo de Ajuste de Gráfico. La unidad tarda un minuto para salir del Modo de Ajuste de Gráfico cuando se pulsa PEN HOME.
7. Pulse el botón PEN HOME para retornar los estiletes al gráfico.
8. Coloque el registrador KT6 en una superficie plana libre de vibraciones. Compruebe que esté en posición vertical y nivelado. Para rendimiento máximo y larga vida útil, la unidad requiere un entorno limpio, libre de polvo y humos corrosivos. No se debe exceder las especificaciones de temperatura.

Montaje en pared: En el registrador KT6 se suministran ranuras de chaveta para montaje en pared.

### Visualización de símbolos (KT622-23-25)

Figura 1

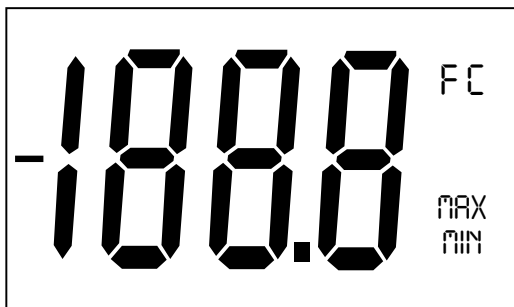

**Figura 2**  
**KT623/25**

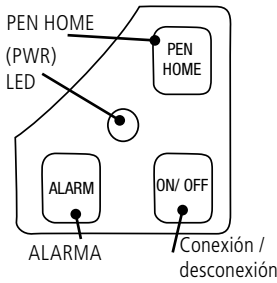

**KT621/22**

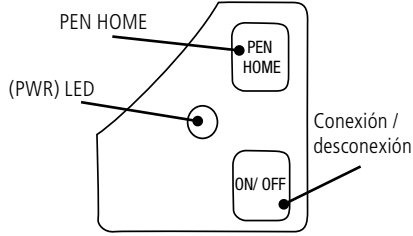

## Operaciones con botones

### CONEXIÓN/DESCONEXIÓN

La tecla de conexión/desconexión activa y desactiva la unidad.

### PEN HOME

Si el(los) estilete(s) están colocados en el borde exterior del gráfico, pulse PEN HOME para colocarlo(s) en posición de grabación. Si el(los) estilete(s) está(n) colocados en el gráfico, pulse la tecla PEN HOME para moverlo(s) hacia el borde exterior del gráfico.

### ALARMA – (KT623-25)

1. Para ajustar la alarma, compruebe que la unidad esté conectada y pulse y mantenga apretado el botón ALARM. El LED parpadea rápidamente en rojo alrededor de cinco segundos, y luego pasa a ser de color verde entero. Libere el botón ALARM Y el LED se apaga. En este momento, la visualización muestra lo siguiente: ON o bien OFF.
2. Al pulsar los botones ADJUST-UP o ADJUST-DOWN, situados en la parte posterior de la unidad junto al interruptor Dip, la alarma alterna entre conexión o desconexión.
3. Al pulsar PEN HOME, se desplaza hacia la siguiente opción de alarma. Las opciones son las siguientes:
  - a. Alarma conectada o desconectada
  - b. Estilete 1 alarma mínima
  - c. Estilete 1 alarma máxima
4. Con el objeto de ajustar las alarmas mínimas y máximas de los estiletos, pulse ADJUST-UP para aumentar el valor de la alarma y ADJUST-DOWN para disminuir su valor. Se produce aceleración si se mantiene apretado el botón ADJUST-UP. Pulse repetidamente el botón PEN HOME para que se desplace a través de las cinco opciones hasta que se pulse el botón de alarma para salir de ajuste de alarma. Cada pulsación del botón PEN HOME o ALARM permite el almacenamiento de los nuevos parámetros. La unidad requiere un minuto para salir del modo de ajuste de alarma una vez que se pulse el botón ALARM.
5. Si se activa la alarma, el LED aparece de color rojo entero y la alarma emite un sonido. Pulse el botón ALARM para silenciar una alarma audible.

## Relés con alarma (KT625)

Los contactos del relé SPST 24V 500mA están normalmente abiertos y se cierran en condiciones de alarma cuando éstas se activan. Los contactos del relé son siempre funcionales cuando se activa la alarma. El relé sólo se cierra durante condiciones de alarma mínimas y máximas.

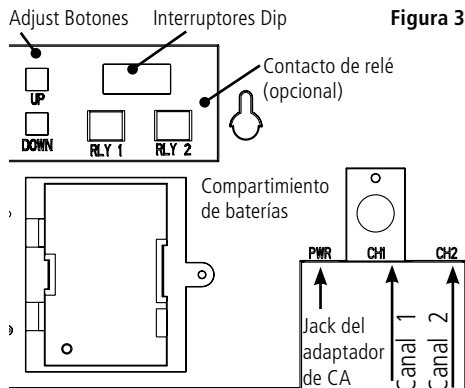

# Instalación de interruptor Dip

Para configurar el registrador KT6 en su aplicación concreta, sería necesario cambiar algunos de los interruptores Dip. Los interruptores Dip están situados en la parte posterior de la unidad (figura 3). Utilice una lapicera o destornillador pequeño para soltar los interruptores. **Recuerde que el gráfico que instale para que sea correcto debe coincidir con los parámetros de los interruptores Dip.**

Comutación deslizante hacia arriba para posición de conexión.

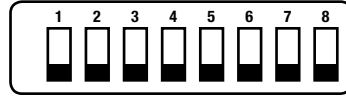

Comutación deslizante hacia abajo para posición de desconexión.

## Interruptores Dip para gamas

DICKSON KT6 Dip Switch Settings:						
Switches 2-6	For Model	2	3	4	5	6
Up = On; Down = Off #25202						
7 Day	All Models	D				
24 Hour	All Models	U				
Fahrenheit	All Models		D			
Celsius	All Models		U			
0 to +100°F/C	All Models			D	D	D
-50 to 0°F/C	All Models			D	D	U
-100 to 0°F/C	All Models			D	U	U
0 to +50°F/C	All Models			D	U	D
+50 to +100°F/C	All Models			U	U	U
0 to +500°F	All Models			U	U	D
0 to +250°F/C	All Models			U	D	U
-50 to +50°F/C	All Models			U	D	D

Remember to install the correct chart for your range  
**Dickson** - Addison, IL - [www.dicksondata.com](http://www.dicksondata.com)

## Tiempo de grabación

El registrador KT6 tiene dos opciones diferentes de tiempo de grabación.

24 Hora	#2 Arriba
7 Día	#2 Abajo

## Seleccione °F ó °C

°F	#3 Abajo
°C	#3 Arriba

## La garantía Dickson

Dickson garantiza que la línea de instrumentos KT6 no presentará defectos de material y de mano de obra en el uso y servicio normales durante un periodo de doce meses posteriores a la entrega.

Esta garantía no cubre calibración de rutina, estiletes, gráficos y reemplazo de batería.

Para Asistencia Técnica entre en la dirección Web: [www.dicksondata.com](http://www.dicksondata.com)

## Temperaturbereich

### KT86 Interruptores Dip para gamas

0 to +100°F/C	#4 Abajo	#5 Abajo	#6 Abajo
-50 to 0°F/C	#4 Abajo	#5 Abajo	#6 Arriba
-100 to 0°F	#4 Abajo	#5 Arriba	#6 Arriba
-50 to +50°F/C	#4 Arriba	#5 Abajo	#6 Abajo
0 to +50°F/C	#4 Abajo	#5 Arriba	#6 Abajo
+50 to +100°F/C	#4 Arriba	#5 Arriba	#6 Arriba
0 to +500°F	#4 Arriba	#5 Arriba	#6 Abajo
0 to +250°F/C	#4 Arriba	#5 Abajo	#6 Arriba

# DICKSON KT621/622/623/625

## Enregistreur de détection à distance de température

### Débuter

1. Votre enregistreur a été configuré pour fonctionner avec les paramètres les plus courants.  
Durée d'enregistrement: 7 jour(s)  
Portée: 0 à 100°F  
Veuillez vous référer au chapitre Configuration de commutateur Dip de ce manuel pour changer les paramètres de durée d'enregistrement et de portée.
2. Retirez les bouchons protecteurs des stylos.
3. Insérez une pile 9V/AA et branchez l'adaptateur AC. (Veuillez consulter la figure 3)
4. L'instrument déplacera les stylos selon les lectures appropriées.
5. Installez le graphe correspondant aux paramètres de commutateur Dip sélectionné.
  - a. Pressez la touche PEN HOME pour déplacer le stylo hors du graphe. Le stylo est automatiquement retiré hors du graphe.
  - b. Retirez l'ancien graphe, placez le nouveau graphe sur le connecteur de graphe en vous assurant que le bord du graphe glisse sous les clips de guidage de graphe situés en dehors du graphe.
6. Fixez l'heure appropriée. Il existe deux méthodes pour ajuster le graphe et fixer l'heure appropriée:
  - a. Fixez manuellement l'heure du graphe en insérant une pièce dans la fente du connecteur de graphe et en tournant dans le sens des aiguilles d'une montre jusqu'à arriver à l'heure correcte (et le jour, si cela est applicable) sur la flèche de durée sur le graphe (juste à droite du bout du stylo sur le composeur).
  - b. (Cette fonction ne devrait être utilisée que pour l'affinage de l'ajustage) Pour ajuster l'heure du graphe, pressez et maintenez enfoncés les boutons ADJUST-UP et ADJUST-DOWN situés à l'arrière de l'unité près du commutateur Dip (Veuillez consulter la figure 3). La diode LED verte clignotera rapidement pendant près de cinq secondes puis restera au vert. Dans cet état, le bouton ADJUST-UP fera avancer le graphe (dans le sens des aiguilles d'une montre) et le bouton ADJUST-DOWN le fera reculer (dans le sens contraire de celui des aiguilles d'une montre). Faites tourner le graphe jusqu'à arriver à l'heure correcte (et le jour, si cela est applicable) sur la flèche de durée sur le graphe. Une fois que vous avez configuré votre graphe, pressez le bouton PEN HOME pour sortir du mode d'ajustage de graphe (Chart Adjust). L'unité prendra une minute pour sortir du mode d'ajustage de graphe une fois que PEN HOME est pressé.
7. Pressez PEN HOME pour déplacer les stylos sur le graphe.
8. Placez l'enregistreur KT6 sur une surface plane sans vibrations. Assurez-vous d'une position verticale et d'une mise à niveau. Pour une meilleure performance et longévité, l'emplacement devrait être dans le cadre d'un environnement propre, sans poussières ou vapeurs corrosives. Ne dépassez pas les spécifications de température.

Pose murale: Des fentes sont réservées à la pose murale de l'enregistreur KT6.

### Affichage de symboles (KT622-23-25)

Figure 1

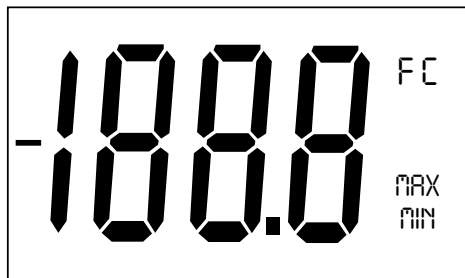

**Figure 2**  
**KT623/25**

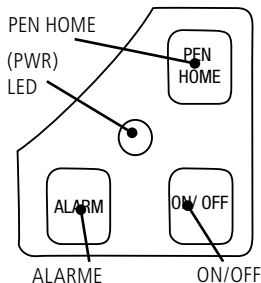

**KT621/22**

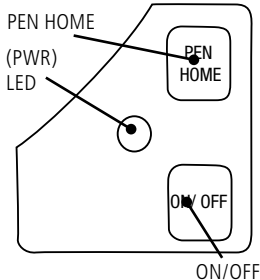

## Opérations des boutons

### ON/OFF

La touche On/Off active ou désactive l'unité.

### PEN HOME

Si le ou les stylos sont situés sur le bord extérieur du graphe, pressez PEN HOME pour les déplacer en position d'enregistrement. Si le ou les stylos sont situés sur le graphe, pressez PEN HOME pour les déplacer vers le bord extérieur du graphe.

### ALARM - (KT623-25)

- Pour fixer une alarme, assurez-vous que l'unité est activée puis pressez et maintenez enfoncé le bouton ALARM. La diode LED rouge clignotera rapidement pendant près de cinq secondes puis passera au vert solide. Relâchez le bouton ALARM et la diode LED s'éteindra. A ce point, l'affichage indiquera les détails suivants: ON ou OFF.
- Une pression sur un des boutons ADJUST-UP ou ADJUST-DOWN situés à l'arrière de l'unité près du commutateur Dip activera ou désactivera l'alarme.
- Une pression sur PEN HOME fera défiler vers l'option suivante de l'alarme. Les options sont comme suit:
  - alarme activée ou désactivée
  - alarme min. Stylo 1
  - alarme max. Stylo 1
- Pour ajuster les valeurs d'alarme minimum et maximum du stylo, pressez ADJUST-UP pour augmenter la valeur d'alarme et ADJUST-DOWN pour la diminuer. Il y aura une accélération si le bouton ADJUST-UP est maintenu enfoncé. Une pression répétée de PEN HOME fera défiler les cinq options jusqu'à ce que soit pressé le bouton d'alarme pour quitter l'ajustage d'alarme. Chaque pression sur PEN HOME ou sur ALARM permettra le stockage des nouvelles valeurs. Il prendra à l'unité une minute pour quitter le mode ALARM SET une fois pressé le bouton ALARM.
- Si l'alarme est déclenchée, la diode LED indiquera une couleur rouge solide et une alarme sera entendue. Pressez le bouton ALARM pour mettre au silence l'alarme sonore.

## Relais d'alarme (KT625)

Les contacts de relais SPST 24V 500mA sont normalement ouverts et seront fermés lorsque les conditions d'alarmes seront activées. Les contacts de relais sont toujours fonctionnels lorsque l'alarme est activée. Le commutateur Dip N° 8 n'a aucun effet sur le relais. Le relais ne se fermera que lors de conditions minimales et maximales d'alarmes.

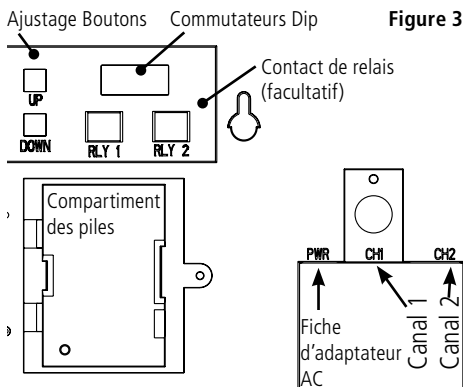

**Figure 3**

# Configuration du commutateur Dip

Pour configurer l'enregistreur KT6 pour votre application spécifique, vous pourriez avoir à changer certains réglages des commutateurs Dip. Les commutateurs Dip sont situés à l'arrière de l'unité (Veuillez consulter la figure 3). Utilisez un stylo ou un petit tournevis pour modifier les réglages des commutateurs. **Souvenez-vous d'installer le graphe correct correspondant au réglage du commutateur Dip.**

## Commutateurs Dip pour les portées

DICKSON KT6 Dip Switch Settings:						
		#5202				
		Up = On; Down = Off				
Switches 2-6	For Model	2	3	4	5	6
7 Day	All Models	D				
24 Hour	All Models	U				
Fahrenheit	All Models		D			
Celsius	All Models		U			
0 to +100°F/C	All Models			D	D	D
-50 to 0°F/C	All Models			D	D	U
-100 to 0°F/C	All Models			D	U	U
0 to +50°F/C	All Models			D	U	D
+50 to +100°F/C	All Models			U	U	U
0 to +500°F	All Models			U	U	D
0 to +250°F/C	All Models			U	D	U
-50 to +50°F/C	All Models			U	D	D

Remember to install the correct chart for your range  
**Dickson** - Addison, IL [www.dicksondata.com](http://www.dicksondata.com)

## Heure d'enregistrement

L'enregistreur KT6 dispose de trois / deux options différentes de durée d'enregistrement

24 Heure	#2 Haut
7 Jour	#2 Bas

## Sélectionnez F° ou C°

°F	#3 Bas
°C	#3 Haut

## La garantie Dickson

Dickson garantit que la ligne KT6 d'instruments sera sans défauts en matériel et en fabrication sous un usage normal et sera sous service pour une période de douze mois après la livraison.

Cette garantie ne couvre pas l'étalonnage de routine, le stylo, le graphe et le remplacement de piles.

Visitez le site [www.dicksondata.com](http://www.dicksondata.com) pour l'assistance technique.

## Portée de température

KT6 Commutateurs Dip pour les portées

0 to +100°F/C	#4 Bas #5 Bas #6 Bas
-50 to 0°F/C	#4 Bas #5 Bas #6 Haut
-100 to 0°F	#4 Bas #5 Haut #6 Haut
-50 to +50°F/C	#4 Haut #5 Bas #6 Bas
0 to +50°F/C	#4 Bas #5 Haut #6 Bas
+50 to +100°F/C	#4 Haut #5 Haut #6 Haut
0 to +500°F	#4 Haut #5 Haut #6 Bas
0 to +250°F/C	#4 Haut #5 Bas #6 Haut

# DICKSON KT621/622/623/625

## Temperaturaufzeichnung durch Fernerkundung (Remote Sensing)

### Schnellstart

1. Ihr Aufzeichnungsgerät wurde voreingestellt, um esunter den meist verwendeten Einstellungen zu betreiben.  
Aufzeichnungszeit: 7 Tag  
Bereich: 0 bis 100°F  
Um Bereich und Aufzeichnungszeit zu ändern, lesen Sie bitte in diesem Leitfaden unter Abblendschalter Einstellungen weiter.
2. Entfernen Sie die Schutzkappen des Stifts.
3. 9V/AA-Batterie einfügen und in Wechselstromadapter stecken (siehe Abbildung 3)
4. Das Instrument bewegt die Stäbe auf die ordnungsgemäßen Ablesewerte.
5. Installieren Sie das Diagramm, das mit den von Ihnen gewählten Einstellungen des Abblendschalters übereinstimmt.
  - a. Betätigen Sie die STIFT HOME Taste, um den Stab zur Außenseite des Diagramms zu bewegen. Der Stab wird selbständig vom Diagramm weg nach oben bewegt.
  - b. Entfernen Sie das alte Diagramm, legen sie das neue Diagramm auf die Diagrammscheibe - vergewissern Sie sich, dass die Kante der Diagrammfolien sich unter den Leitklemmen des Diagramms auf der Diagrammaußenseite befindet.
6. Stellen Sie die richtige Zeit ein. Es gibt zwei Verfahren, um das Diagramm anzupassen und eine angemessene Zeit einzustellen:
  - a. Stellen Sie die Zeit von Hand ein, indem Sie eine Münze in die Rille der Diagrammdrehscheibe einführen und diese im Uhrzeigersinn bis zur richtigen Stunde drehen (und Tag, wenn sich dies als der Fall erweisen sollte); auf dem Diagramm auf den Timing-Pfeil (unmittelbar rechts neben der Spitze des Schreiberspitze der Wählerscheibe.
  - b. (Dieses Feature sollte nur zur Feineinstellung verwendet werden) Um die Diagrammzeit einzustellen, passen Sie die Diagrammzeit an, drücken und halten Sie die neben dem Abblendschalter (siehe Abbildung 3) auf der Rückseite der Geräteeinheit befindlichen ADJUST-UP und ADJUST-DOWN gedrückt. Die grüne LED blinkt in schneller Folge etwas fünfmal auf, danach verbleibt die LED in einem satten Grün In diesem Zustand bewegt der ADJUST-UP Button das Diagramm weiter (im Uhrzeigersinn) und der ADJUST-DOWN Button bewegt das Diagramm rückwärts weiter (entgegen dem Uhrzeigersinn). Rotieren Sie das Diagramm solange weiter, bis auf dem Diagramm der Zeiteiger auf die korrekte Stunde (und Tag, falls angebracht) zeigt. Nachdem Sie das Diagramm eingestellt haben, drücken Sie den STIFT HOME Button, um den Diagramm-Einrichtungsmodus zu verlassen. Nach Drücken des STIFT HOME Buttons dauert es eine Minute bis zum Verlassen des Diagramm-Einrichtungsmodus.
7. Drücken Sie STIFT HOME, um den Stift auf das Diagramm zurück zu bewegen.
8. Stellen Sie das KT6 Aufzeichnungsgerät auf eine flache, vibrationsfreie Oberfläche Vergewissern Sie sich, dass es sich in einer senkrechten Position und Lage befindet. Eine saubere, staubfreie Umgebung frei von Korrosionsdämpfen sind die Voraussetzung für optimale Leistung und Lebensdauer. Überschreiten Sie nicht die Temperaturvorschriften.

Wandhalterung: Schlüsselloch-Schlitzte werden auf dem KT6 Aufzeichnungsgerät zwecks Wandbefestigung zur Verfügung gestellt.

### Symboloptionen anzeigen

#### (KT622-23-25)

Abbildung 1



Abbildung 2  
KT623/25



KT621/22

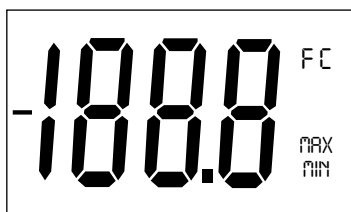
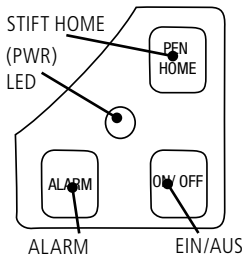
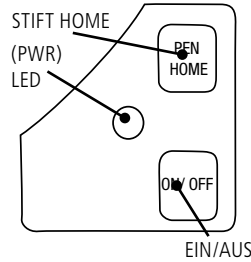

## Knopfbedienungen

### EIN/AUS (ON/OFF)

Die Ein/Aus- (On/Off) Taste schaltet die Geräteeinheit an oder aus.

### STIFT HOME

Falls der/(die) Stift(e) sich auf dem Außenrand des Diagramms befinden, drücken Sie STIFT HOME, um den/(die) Stift(e) in die Aufzeichnungsstellung zu bewegen. Falls sich der/(die) Stift(e) auf dem Diagramm befindet, drücken Sie die STIFT HOME Taste, um den/(die) Stift(e) auf den Außenrand des Diagramms zu bewegen.

### ALARM – (KT623-25)

- Um den Alarm einzustellen, vergewissern Sie sich, dass die Geräteeinheit eingeschaltet ist. Dann drücken Sie den ALARM Button und halten diesen danach weiterhin gedrückt. Die LED blinkt in schneller Folge etwa fünfmal auf, danach verbleibt die LED in einem satten Grün. Nach Loslassen des ALARM Buttons erlischt die LED. In diesem Zustand zeigt die Anzeige folgendes an: EIN (ON) oder AUS (OFF).
- Durch Drücken der ADJUST-UP oder ADJUST-DOWN Knöpfe, die sich auf der Rückseite der Geräteeinheit neben dem Abblendschalter befinden, ermöglicht das Ein- und Ausschalten des Alarms.
- Durch Drücken von STIFT HOME bewegt man sich in der Anzeige zur nächsten Bildoption. Folgende Optionen sind gegeben:
  - Alarm ein oder aus
  - Stift 1 Alarm min
  - Stift 1 Alarm max
- Zum Einrichten der Mindest- und Höchsteinstellungen des Alarms für den Stift wird durch Drücken von ADJUST-UP der Alarmwert erhöht und durch Drücken von ADJUST-DOWN der Alarmwert erniedrigt. Durch Gedrückthalten des ADJUST-UP Buttons wird dieser Einstellvorgang beschleunigt. Wiederholtes Drücken des STIFT HOME Knopfes bewegt die Anzeige durch fünf Optionen, bis der Alarmknopf gedrückt wird, um die Alarmanpassung zu verlassen. Jedes Drücken des STIFT HOME oder ALARM Knopfes speichert die neuen Einstellungen. Die Geräteeinheit benötigt eine Minute zum Verlassen des Alarmeinstellmodus, nachdem der ALARM Knopf gedrückt wurde.
- Falls der Alarm ausgelöst wurde, die LED leuchtet in rot und der Alarm erklingt. Drücken Sie den ALARM Knopf, um den hörbaren Alarm stumm zu schalten.

## Alarmrelais (KT625)

Die SPST 24V 500mA Relaiskontakte sind normalerweise geöffnet und schließen sich, wenn Alarmbedingungen gegeben sind und Alarm aktiviert ist. Bei aktiviertem Alarm funktionieren die Relaiskontakte immer. Abblendschalter Nr. 8 beeinflusst das Relais nicht. Das Relais schließt sich nur bei maximalen und minimalen Alarmbedingungen.

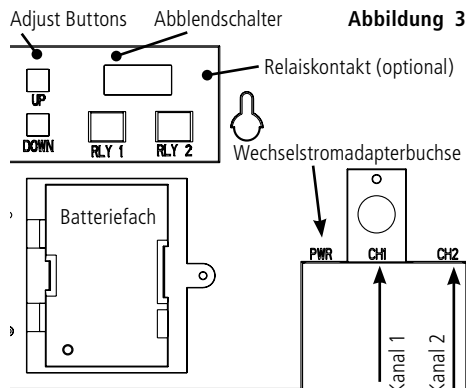

# Einstellen des Abblendschalters

Zum Einstellen des KT6 Aufzeichnungsgeräts für Ihre spezifischen Anwendungen könnte es erforderlich sein, dass Sie die Abblendschalter ändern. Die Abblendschalter befinden sich auf der Rückseite der Geräteeinheit (Abbildung 3). Verwenden Sie einen kleinen Schraubenzieher, um die Schalter umzustellen.

**Denken Sie daran, das korrekte Diagramm zu installieren, die mit der entsprechenden Abblendschaltereinstellung übereinstimmen muss.**

## Abblendschalterbereiche

DICKSON KT6 Dip Switch Settings:						
Up = On; Down = Off #25202						
Switches 2-6	For Model	2	3	4	5	6
7 Day	All Models	D				
24 Hour	All Models	U				
Fahrenheit	All Models		D			
Celsius	All Models		U			
0 to +100°F/C	All Models			D	D	D
-50 to 0°F/C	All Models			D	D	U
-100 to 0°F/C	All Models			D	U	U
0 to +50°F/C	All Models			D	U	D
+50 to +100°F/C	All Models			U	U	U
0 to +500°F	All Models			U	U	D
0 to +250°F/C	All Models			U	D	U
-50 to +50°F/C	All Models			U	D	D

Remember to install the correct chart for your range  
**Dickson** - Addison, IL [www.dicksondata.com](http://www.dicksondata.com)

## Aufzeichnungszeit

Das KT6 Aufzeichnungsgerät verfügt über drei/ zwei verschiedene Optionen zur Aufzeichnungszeit

24 Stunde	#2 Nach
7 Tag	#2 Nach unten

## Wählen Sie °F oder °C

°F	#3 Nach unten
°C	#3 Nach

## Die Dickson Gewährleistung

Dickson gewährleistet, dass die KT6 Produktlinie von Instrumenten für die Dauer von 12 Monate nach Auslieferung und bei normaler Nutzung frei von Material- und Verarbeitungsmängeln ist.

Routinemäßige Kalibrierung und das Ersetzen von Stift, Diagramm und Batterie sind in dieser Gewährleistung nicht enthalten.

Für technischen Support verweisen wir Sie auf [www.dicksondata.com](http://www.dicksondata.com)

## Rangos de Temperatura KT6 Abblendschalterbereiche

0 to +100°F/C	#4 Nach unten #5 Nach unten #6 Nach unten
-50 to 0°F/C	#4 Nach unten #5 Nach unten #6 Nach
-100 to 0°F	#4 Nach unten #5 Nach #6 Nach
-50 to +50°F/C	#4 Nach #5 Nach unten #6 Nach unten
0 to +50°F/C	#4 Nach unten #5 Nach #6 Nach unten
+50 to +100°F/C	#4Nach #5 Nach #6 Nach
0 to +500°F	#4 Nach #5 Nach #6 Nach unten
0 to +250°F/C	#4 Nach #5 Nach unten #6 Nach

**DICKSON**

Product Specifications & Applications

Quick Start/ Operating Instructions

Charts & Accessories

Calibrations/ Troubleshooting & Warranty

Spanish

French

German

Italian

# DICKSON KT621/622/623/625

## Registratore della temperatura rilevata a distanza

### Avvio veloce

1. Il registratore è stato pre-impostato al funzionamento utilizzando le impostazioni più diffuse.  
Ora di registrazione: 7 giorno  
Campo di misura: da 0 a 100°F  
Per modificare il campo di misura e l'ora di registrazione consultare la sezione Impostazione interruttore DIP di questo manuale.
2. Togliere il cappuccino protettivo del pennino.
3. Inserire una batteria da 9V e collegare l'adattatore CA. (vedere figura 3)
4. Lo strumento sposterà i pennini sulle letture idonee.
5. Installare il diagramma che corrisponde alle impostazioni selezionate per l'interruttore Dip.
  - a. Premere il tasto PEN HOME per spostare il pennino all'esterno del diagramma. Il pennino viene automaticamente sollevato dal diagramma.
  - b. Estrarre il vecchio diagramma, inserirne uno nuovo sul perno del diagramma – assicurandosi che il bordo del diagramma scivoli sotto i fermagli di guida del diagramma che si trovano al di fuori dello stesso.
6. Impostare l'ora idonea. Ci sono due modi per regolare il diagramma ed impostare l'ora idonea:
  - a. Impostare manualmente l'ora del diagramma inserendo una moneta nella scanalatura del perno del diagramma e ruotando in senso orario finché l'ora corretta (ed il giorno se applicabile) del diagramma corrisponde a quella indicata dalla freccia (subito a destra della punta del pennino sul quadrante).
  - b. (Questa funzione deve essere usata solo per regolazioni di precisione) Per regolare l'ora del diagramma, premere e tenere premuti i pulsanti ADJUST-UP e ADJUST-DOWN che si trovano a tergo dell'unità vicino all'interruttore Dip (vedere figura 3). Il LED verde lampeggerà per circa cinque secondi, poi il LED resterà costantemente acceso. In queste condizioni il pulsante ADJUST-UP consentirà il movimento del diagramma in avanti (in senso orario) ed il pulsante ADJUST-DOWN consentirà il movimento del diagramma all'indietro (in senso anti-orario). Ruotare il diagramma finché l'ora corretta del diagramma (e giorno se applicabile) corrisponde all'ora indicata dalla freccia. Una volta impostato il diagramma, premere il pulsante PEN HOME per uscire dalla modalità di Regolazione Diagramma. L'unità uscirà dalla modalità di Regolazione Diagramma entro un minuto se si preme il pulsante PEN HOME.
7. Premere il tasto PEN HOME per portare il pennino di ritorno sul diagramma.
8. Sistemare il KT6 registratore su una superficie piana priva di vibrazioni. Assicurarsi che sia in posizione perpendicolare ed a livello. Per migliori prestazioni e durata, l'ubicazione deve essere un ambiente pulito, libero da polvere e fumi corrosivi. Non superare le temperature specificate.

Installazione a parete: Sul registratore KT6 sono stati praticati fori sagomati per l'installazione a parete.

### Simboli visualizzati (KT622-23-25)

Figura 1

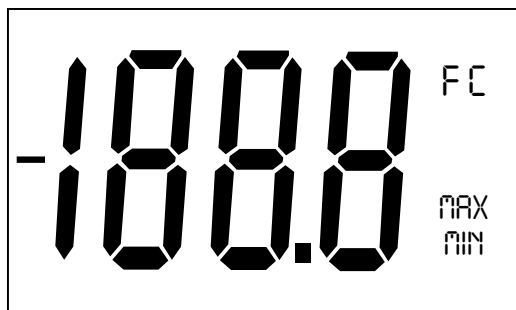

**Figura 2**  
**KT623/25**

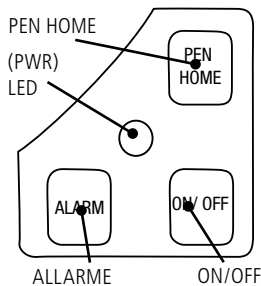

**KT621/22**

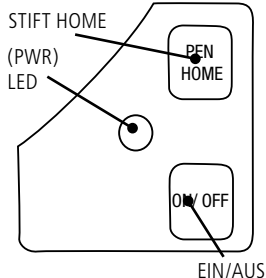

## Funzionamento dei pulsanti

### ON/OFF

Il tasto On/Off serve ad accendere e spegnerà l'unità.

### ORIGINE PENNINO

Se i pennini si trovano al di là del bordo del diagramma, premere il tasto PEN HOME per riportare il pennino alla posizione di registrazione. Se i pennini si trovano sul diagramma, premere il tasto PEN HOME per portare i pennini sul bordo esterno del diagramma.

### ALLARME - (KT623-25)

- Per impostare l'allarme, assicurarsi che l'unità sia accesa e premere e tenere premuto il pulsante ALARM. Il LED rosso lampeggerà rapidamente per circa cinque secondi, poi il LED resterà costantemente a luce verde. Rilasciando il pulsante ALARM il LED si spegne. A questo punto il display visualizzerà quanto segue: ON oppure OFF.
- Premendo il pulsante ADJUST-UP o quello ADJUST-DOWN, che si trovano a tergo dell'unità vicino all'interruttore Dip, si attiva o disattiva l'allarme.
- Premendo PEN HOME si passa all'opzione d'allarme successiva. Le possibilità sono:
  - allarme attivato o disattivato
  - pennino 1 allarme di minima
  - pennino 1 allarme di massima
- Per impostare i valori minimi o massimi d'allarme per un pennino, premendo ADJUST-UP si aumenta il valore dell'allarme e premendo ADJUST-DOWN si diminuisce il valore dell'allarme. Si accelera se il pulsante ADJUST-UP è tenuto premuto. Premendo ripetutamente il pulsante PEN HOME si scorrono le 5 possibilità fino a quando il pulsante d'allarme viene premuto per uscire dalla regolazione dell'allarme. Ciascuna pressione del pulsante PEN HOME o di quello ALARM INSERIRÀ IN MEMORIA LE NUOVE IMPOSTAZIONI. L'unità uscirà dalla modalità di Regolazione Diagramma entro un minuto se si preme il pulsante ALARM.
- Se viene azionato l'allarme, il LED sarà acceso a luce rossa stabile e si udrà l'allarme. Premere il pulsante ALARM per interrompere l'allarme sonoro.

## Relè d'allarme (KT625)

I contatti del relè SPST 24V 500 mA sono normalmente aperti e si chiuderanno in condizioni d'allarme quando gli allarmi sono attivabili. I contatti del relè sono sempre operativi quando l'allarme è attivabile. L'interruttore Dip #8 non influisce sul relè. Il relè si chiude solo nelle condizioni minime e massime d'allarme.

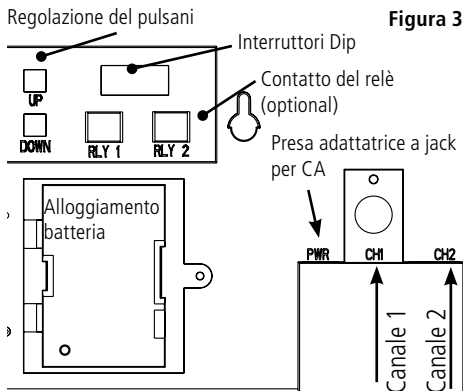

# Impostazione dell'interruttore Dip

Per impostare il registratore KT6 per un'applicazione specifica, può essere necessario cambiare alcuni degli interruttori Dip. Gli interruttori Dip si trovano a tergo dell'unità (figura 3). Per agire sugli interruttori usare una penna o un piccolo cacciavite. **Assicurarsi di installare il diagramma corrispondente alle impostazioni degli interruttori Dip.**

## Interruttori Dip per i campi di misura

DICKSON KT6 Dip Switch Settings:						
Up = On; Down = Off		#25202				
Switches 2-6	For Model	2	3	4	5	6
7 Day	All Models	D				
24 Hour	All Models	U				
Fahrenheit	All Models		D			
Celsius	All Models		U			
0 to +100°F/C	All Models			D	D	D
-50 to 0°F/C	All Models			D	D	U
-100 to 0°F/C	All Models			D	U	U
0 to +50°F/C	All Models			D	U	D
+50 to +100°F/C	All Models			U	U	U
0 to +500°F	All Models			U	U	D
0 to +250°F/C	All Models			U	D	U
-50 to +50°F/C	All Models			U	D	D

Remember to install the correct chart for your range  
**Dickson** - Addison, IL [www.dicksondata.com](http://www.dicksondata.com)

## Ora di registrazione

Il registratore KT6 possiede tre possibilità diverse per l'ora di registrazione

24 Ora	#2 Su
7 Giorno	#2 Giù

## Selezionare °F o °C

°F	#3 Giù
°C	#3 Su

## La garanzia Dickson

Dickson garantisce che la linea di strumenti KT6 sarà priva di difetti di materiale e manodopera nelle condizioni normali d'uso e di servizio per il periodo di dodici mesi dalla consegna.

Questa garanzia non copre la Calibrazione di routine, il pennino, il diagramma e la sostituzione della batteria.

Per l'assistenza tecnica accedere al sito [www.dicksondata.com](http://www.dicksondata.com)

## Campo temperatura

KT6 Interruttori Dip per i campi di misura

0 to +100°F/C	#4 Giù #5 Giù #6 Giù
-50 to 0°F/C	#4 Giù #5 Giù #6 Su
-100 to 0°F	#4 Giù #5 Su #6 Su
-50 to +50°F/C	#4 Su #5 Giù #6 Giù
0 to +50°F/C	#4 Giù #5 Su #6 Giù
+50 to +100°F/C	#4 Su #5 Su #6 Su
0 to +500°F	#4 Su #5 Su #6 Giù
0 to +250°F/C	#4 Su #5 Giù #6 Su