

# FLEX200 & FLEX240



## LED Floodlights



### Key Features:

- Suitable for security & general outdoor lighting applications
- Industrial design embedding user convenience and flexibility
- Cast metal casing with high quality grained anodised paint finish
- Corrosion and UV resistant
- Proven provider of switch-mode power supplies to support in-house LED driver technology
- Quality, long life LEDs & polished reflector for maximum light output
- Dual redundancy driver technology
- Designed to provide applications long product life cycle & high energy saving capabilities
- Optional available motion detector & automatic day/night sensor functionality
- Suitable for dry / damp /wet locations

### FLEX200 & FLEX240 SPECIFICATION

Part Code	FLEX-200C	FLEX-200W	FLEX-240C	FLEX-240W
Input Voltage	180 ~ 265VAC	180 ~ 265VAC	90 ~ 305VAC	90 ~ 305VAC
Input Frequency	47/63Hz	47/63Hz	47/63Hz	47/63Hz
Power Factor	>0.96	>0.96	>0.97	>0.97
Efficiency	>90%	>90%	>90%	>90%
Input Power	<225W	<225W	<265W	<265W
Fitting Colour	Black	Black	Black	Black
Lumen Output	>18000lm	>18000lm	>20500lm	>20500lm
CRI	>80	>80	>80	>80
Colour (K)	6000-7000K	3000-4000K	6000-7000K	3000-4000K
Efficiency	85lm/W	85lm/W	83lm/W	83lm/W
Operating Temperature	-40°C ~ +40°C	-40°C ~ +40°C	-40°C ~ +40°C	-40°C ~ +40°C
Beam Angle	120°	120°	120°	120°
Weight	15Kg	15Kg	15Kg	15Kg
Dimensions	515 x 467 x 150 mm	515 x 467 x 150 mm	515 x 467 x 150 mm	515 x 467 x 150 mm

### Mechanical Diagrams - FLEX200 & FLEX240

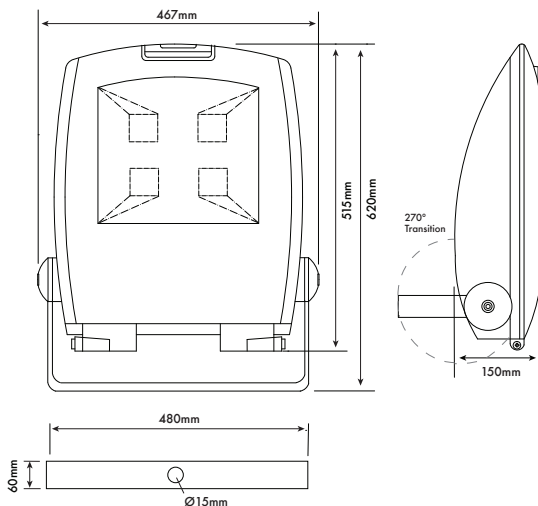

PowerLed (UK) Ltd  
Orion House  
Calleva Park  
Aldermaston  
Berkshire  
RG7 8SN

Contact:  
Tel: 0118 9703856  
enquiries@powerled.uk.com  
www.powerled.uk.com



# FLEX LED Floodlights

## Available Variants

### Clear Polycarbonate Lens

The FLEX LED Floodlight is available with shatterproof clear polycarbonate lens for applications where our standard glass version would not be suitable, such as food or crop storage; and are available for 30W, 50W, 80W, 100W, 120W, 200W & 240W Flex floodlights.



PCL00	Clear Poly Carbonate	00=30W, 50W, 80W, 100W, 120W, 200W & 240W
-------	----------------------	---

### Coloured Lens

Coloured lenses are available for the entire range of FLEX LED floodlights offering a constant translucent colour.

FLEX-00A	Amber	00=10W, 30W, 50W, 80W, 100W, 120W, 200W & 240W
FLEX-00B	Blue	00=10W, 30W, 50W, 80W, 100W, 120W, 200W & 240W
FLEX-00G	Green	00=10W, 30W, 50W, 80W, 100W, 120W, 200W & 240W
FLEX-00R	Red	00=10W, 30W, 50W, 80W, 100W, 120W, 200W & 240W



### DD Suffix - Integral Dusk to Dawn Sensor

Available for 50 ~ 240W models, this optional Dusk to Dawn sensor will ensure your FLEX floodlight automatically switches on at dusk and off again at dawn; lighting your outdoor space only during the hours of need.

### Special Colour Powder Coat Finishes

The Flex range is also available in a range of colour powder coat finishes; and are available for the 30W, 50W, 80W, 100W, 120W, 200W & 240W.

RAL 9016M	Traffic White
RAL 7016M	Anthracite Grey
RAL 6005M	Moss Green
BS 08 B 29M	Vandyke Brown

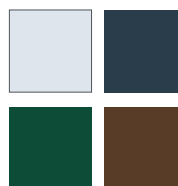

Other special colours are available on request.

### FLEX Accessory - PIR700

The PIR700 LED light sensor is available for the entire FLEX range.



PowerLed (UK) Ltd  
Orion House  
Calleva Park  
Aldermaston  
Berkshire  
RG7 8SN

Contact:  
Tel: 0118 9703856  
enquiries@powerled.uk.com  
www.powerled.uk.com



# FLEX LED Floodlights

---

## Testing & Certification

The FLEX 200 & 240 floodlight has been extensively tested to the following criteria:-

### Salt Spray Test

IEC 60068-2-52 specifies the application of the cyclic salt mist test to components or equipment designed to withstand a salt-laden atmosphere as salt can degrade the performance of parts manufactured using metallic and/or non-metallic materials.

### International Protection (IP) Rating

IEC 60529, sometimes interpreted as Ingress Protection Marking, classifies and rates the degree of protection provided against intrusion (body parts such as hands and fingers), dust, accidental contact, and water by mechanical casings and electrical enclosures. It is published by the International Electrotechnical Commission (IEC). The equivalent European standard is EN 60529.

### CE Certificate of Conformity

CE marking is a certification mark that indicates conformity with health, safety, and environmental protection standards for products sold within the European Economic Area (EEA). This also includes EMI, EMS, Low Voltage Directive and Energy Related Products Directive.

### ECA compliance Certificate

Photometric Reports

Driver Data

Copies of these certificates and reports are available upon request