

Future Technology Devices International Ltd

FT4232H Quad High Speed USB to Multipurpose UART/MPSSE IC

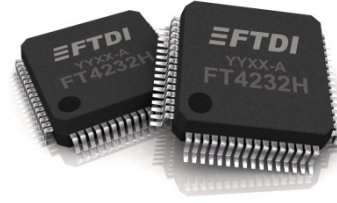

The FT4232H is FTDI's 5th generation of USB devices. The FT4232H is a USB 2.0 High Speed (480Mb/s) to UART/MPSSE ICs. The device features 4 UARTs. Two of these have an option to independently configure an MPSSE engine. This allows the FT4232H to operate as two UART/Bit-Bang ports plus two MPSSE engines used to emulate JTAG, SPI, I²C, Bit-bang or other synchronous serial modes. The FT4232H has the following advanced features:

- Single chip USB to quad serial ports with a variety of configurations.
- Entire USB protocol handled on the chip. No USB specific firmware programming required.
- USB 2.0 High Speed (480Mbits/Second) and Full Speed (12Mbits/Second) compatible.
- Two Multi-Protocol Synchronous Serial Engine (MPSSE) on channel A and channel B, to simplify synchronous serial protocol (USB to JTAG, I²C, SPI or bit-bang) design.
- Independent Baud rate generators.
- RS232/RS422/RS485 UART Transfer Data Rate up to 12Mbaud. (RS232 Data Rate limited by external level shifter).
- FTDI's royalty-free Virtual Com Port (VCP) and Direct (D2XX) drivers eliminate the requirement for USB driver development in most cases.
- Optional traffic TX/RX indicators can be added with LEDs and an external 74HC595 shift register.
- Adjustable receive buffer timeout.
- Support for USB suspend and resume conditions via PWREN#, SUSPEND# and RI# pins.
- Highly integrated design includes +1.8V LDO regulator for VCORE, integrated POR function and on chip clock multiplier PLL (12MHz – 480MHz).
- FTDI FT232B style, asynchronous serial UART interface option with full hardware handshaking and modem interface signals.
- Fully assisted hardware or X-On / X-Off software handshaking.
- UART Interface supports 7/8 bit data, 1/2 stop bits, and Odd/Even/Mark/Space/No Parity.
- Auto-transmit enable control for RS485 serial applications using TXDEN pin.
- Operational configuration mode and USB Description strings configurable in external EEPROM over the USB interface.
- Low operating and USB suspend current.
- Configurable I/O drive strength (4,8,12 or 16mA) and slew rate.
- Supports bus powered, self powered and high-power bus powered USB configurations.
- UHCI/OHCI/EHCI host controller compatible.
- USB Bulk data transfer mode (512 byte packets in High Speed mode).
- Dedicated Windows DLLs available for USB to JTAG, USB to SPI, and USB to I²C applications.
- +1.8V (chip core) and +3.3V I/O interfacing (+5V Tolerant).
- Extended -40°C to 85°C industrial operating temperature range.
- Compact 64-LD Lead Free LQFP or QFN package
- +3.3V single supply operating voltage range.

Neither the whole nor any part of the information contained in, or the product described in this manual, may be adapted or reproduced in any material or electronic form without the prior written consent of the copyright holder. This product and its documentation are supplied on an as-is basis and no warranty as to their suitability for any particular purpose is either made or implied. Future Technology Devices International Ltd will not accept any claim for damages howsoever arising as a result of use or failure of this product. Your statutory rights are not affected. This product or any variant of it is not intended for use in any medical appliance, device or system in which the failure of the product might reasonably be expected to result in personal injury. This document provides preliminary information that may be subject to change without notice. No freedom to use patents or other intellectual property rights is implied by the publication of this document. Future Technology Devices International Ltd, Unit 1, 2 Seaward Place, Centurion Business Park, Glasgow G41 1HH United Kingdom. Scotland Registered Company Number: SC136640

1 Typical Applications

- Single chip USB to four channels UART (RS232, RS422 or RS485) or Bit-Bang interfaces.
- Single chip USB to 2 JTAG channels plus 2 UARTS.
- Single chip USB to 1 JTAG channel plus 3 UARTS.
- Single chip USB to 1 SPI channel plus 3 UARTS.
- Single chip USB to 2 SPI channels plus 2 UARTS.
- Single chip USB to 2 Bit-Bang channels plus 2 UARTS.
- Single chip USB to 1 SPI channel, plus 1 JTAG channel plus 2 UARTS.
- Single chip USB to 2 I²C channels plus 2 UARTS.
- Numerous combinations of 4 channels.
- Upgrading Legacy Peripheral Designs to USB
- Field Upgradable USB Products
- Cellular and cordless phone USB data transfer cables and interfaces.
- Interfacing MCU / PLD / FPGA based designs to USB
- PDA to USB data transfer
- USB Smart Card Readers
- USB Instrumentation
- USB Industrial Control
- USB MP3 Player Interface
- USB FLASH Card Reader / Writers
- Set Top Box PC - USB interface
- USB Digital Camera Interface
- USB Bar Code Readers

1.1 Driver Support

The FT4232H requires USB drivers (listed below) , available free from <http://www.ftdichip.com>, which are used to make the FT4232H appear as a virtual COM port (VCP). This allows the user to communicate with the USB interface via a standard PC serial emulation port (for example TTY). Another FTDI USB driver, the D2XX driver, can also be used with application software to directly access the FT4232H through a DLL.

Royalty free VIRTUAL COM PORT (VCP) DRIVERS for...

- Windows 2000, Server 2003, Server 2008
- Windows XP and XP 64-bit
- Windows Vista and Vista 64-bit
- Windows XP Embedded
- Windows CE 4.2, 5.0, 5.2 and 6.0
- Mac OS-X

Royalty free D2XX Direct Drivers (USB Drivers + DLL S/W Interface)

- Windows 2000, Server 2003, Server 2008
- Windows XP and XP 64-bit
- Windows Vista and Vista 64-bit
- Windows XP Embedded
- Windows CE 4.2, 5.0, 5.2 and 6.0
- Linux (2.4 or later) and Linux x86_64

For driver installation, please refer to the application note:

- **AN_106, "Advanced Driver Options".**

The following additional installation guides and technical notes are also available:

- **AN_103, "FTDI Drivers Installation Guide for VISTA".**
- **AN_104, "FTDI Drivers Installation Guide for WindowsXP".**
- **AN_109, "Programming Guide for High Speed FT232RL DLL".**
- **AN_110, "Programming Guide for High Speed FT232RL JTAG DLL".**
- **AN_111, "Programming Guide for High Speed FT232RL SPI DLL".**
- **AN_113, "Interfacing FT232RL Hi-Speed Devices To I2C Bus".**
- **TN_104, "Guide to Debugging Customers Failed Driver Installation".**

1.2 Part Numbers

Part Number	Package
FT4232HL-XXXX	64 Pin LQFP
FT4232HQ-XXXX	64 Pin QFN

Note: Packing codes for xxxx is:

- Reel: Taped and Reel (LQFP =1000 pcs per reel, QFN =4000 pcs per reel)
- Tray: Tray packing, (LQFP =160 pcs per tray, QFN =260 pcs per tray)

Please refer to section 8 for all package mechanical parameters.

1.3 USB Compliant

At the time of writing this datasheet, the FT4232H (Rev B) was still to complete USB compliancy testing.

2 FT4232H Block Diagram

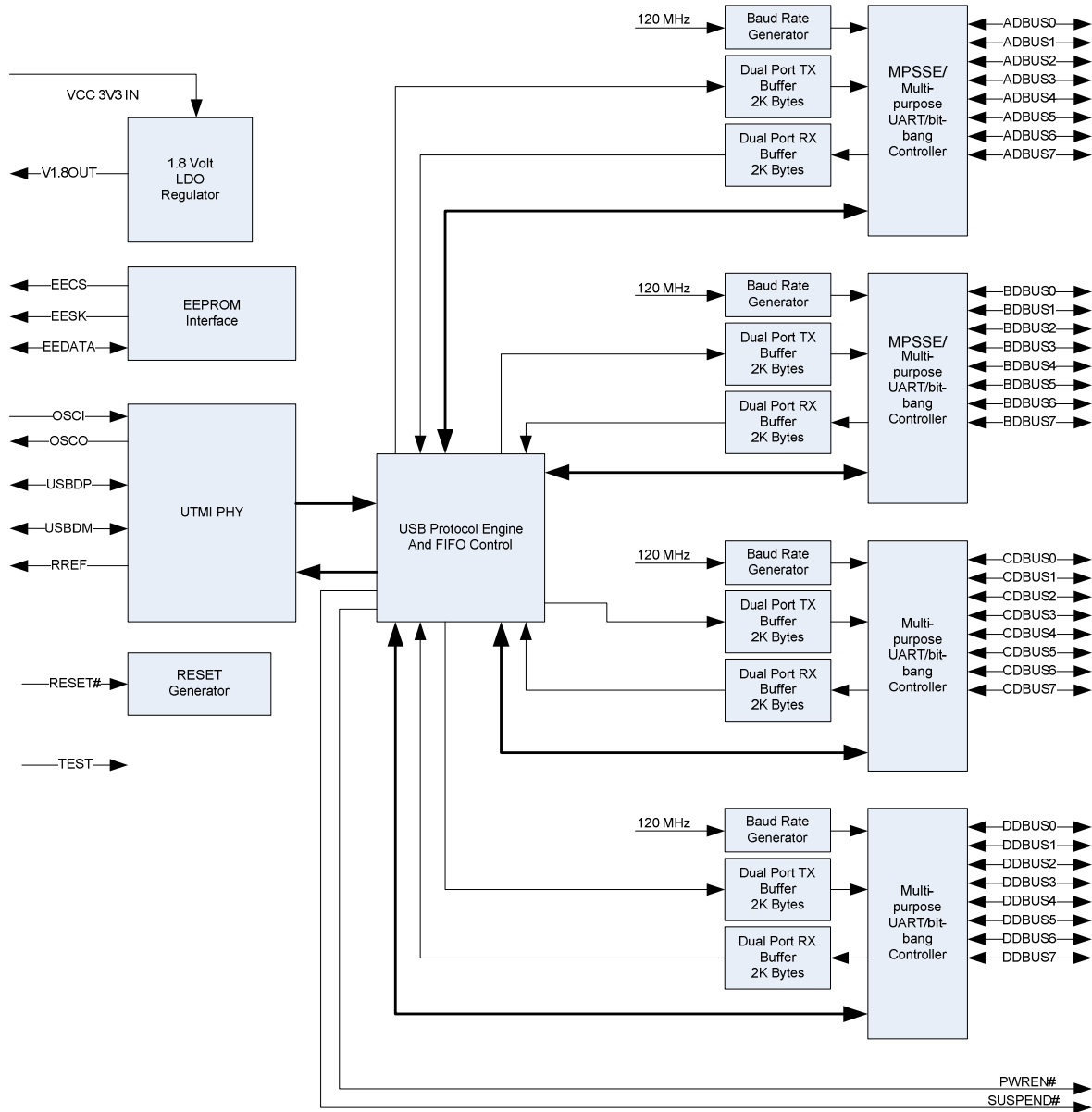

Figure 2.1 FT4232H Block Diagram

For a description of each function please refer to Section 4.

Table of Contents

1	Typical Applications.....	2
1.1	Driver Support	2
1.2	Part Numbers.....	3
	Note: Packing codes for xxxx is:.....	3
1.3	USB Compliant	3
2	FT4232H Block Diagram	4
3	Device Pin Out and Signal Description.....	7
3.1	64-Pin LQFP and 64-Pin QFN Package Schematic Symbol	7
3.2	FT4232H Pin Descriptions.....	8
3.3	Common Pins.....	10
3.4	Configured Pins	12
3.4.1	FT4232H pins used as an asynchronous serial interface	12
3.4.2	FT4232H pins used in a Synchronous or Asynchronous Bit-Bang Interface	13
3.4.3	FT4232H pins used in an MPSSE.....	14
4	Function Description.....	15
4.1	Key Features.....	15
4.2	Functional Block Descriptions	15
4.3	FT232 UART Interface Mode Description.....	17
4.3.1	RS232 Configuration	17
4.3.2	RS422 Configuration	18
4.3.3	RS485 Configuration	19
4.4	MPSSE Interface Mode Description.	20
4.4.1	MPSSE Adaptive Clocking.....	21
4.5	Synchronous and Asynchronous Bit-Bang Interface Mode Description 22	
4.6	FT4232H Mode Selection.....	24
5	Devices Characteristics and Ratings	25
5.1	Absolute Maximum Ratings.....	25
5.2	DC Characteristics.....	26
6	FT4232H Configurations	29
6.1	USB Bus Powered Configuration	29
6.2	USB Self Powered Configuration	31
6.3	Oscillator Configuration	33
6.4	4 Channel Transmit and Receiver LED Indication Example	34
7	EEPROM Configuration.....	35
8	Package Parameters.....	36



8.1	FT4232HQ, QFN-64 Package Dimensions	37
8.2	FT4232HL, LQFP-64 Package Dimensions	38
8.3	Solder Reflow Profile	40
9	Contact Information	42
	Appendix A - List of Figures and Tables	43
	List of Tables	43
	Appendix B - Revision History.....	44

3 Device Pin Out and Signal Description

The 64-pin LQFP and 64-pin QFN have the same pin numbering for specific functions. This pin numbering is illustrated in the schematic symbol shown in **Figure 3.1**.

3.1 64-Pin LQFP and 64-Pin QFN Package Schematic Symbol

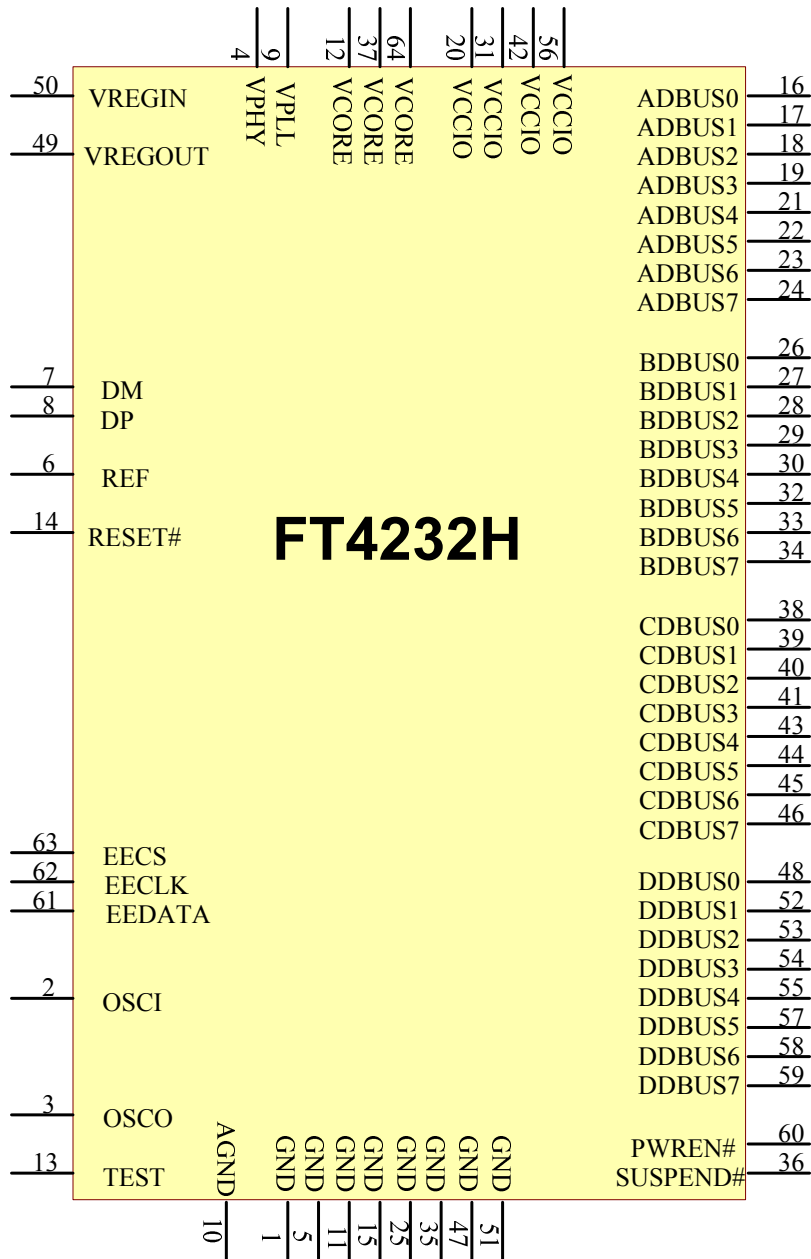

Figure 3.1 FT4232H Schematic Symbol



3.2 FT4232H Pin Descriptions

This section describes the operation of the FT4232H pins. Both the LQFP and the QFN packages have the same function on each pin. The function of many pins is determined by the configuration of the FT4232H. The following table details the function of each pin dependent on the configuration of the interface. Each of the functions are described in **Table 3.1**

(Note: The convention used throughout this document for active low signals is the signal name followed by a #)

FT4232H					
Pins		Pin functions (depend on configuration)			
Pin #	Pin Name	ASYNC Serial (RS232)	ASYNC Bit-bang	SYNC Bit-bang	MPSSSE
Channel A					
16	ADBUS0	TXD	D0	D0	TCK/SK
17	ADBUS1	RXD	D1	D1	TDI/DO
18	ADBUS2	RTS#	D2	D2	TDO/DI
19	ADBUS3	CTS#	D3	D3	TMS/CS
21	ADBUS4	DTR#	D4	D4	GPIOL0
22	ADBUS5	DSR#	D5	D5	GPIOL1
23	ADBUS6	DCD#	D6	D6	GPIOL2
24	ADBUS7	RI#/ TXDEN*	D7	D7	GPIOL3
Channel B					
26	BDBUS0	TXD	D0	D0	TCK/SK
27	BDBUS1	RXD	D1	D1	TDI/DO
28	BDBUS2	RTS#	D2	D2	TDO/DI
29	BDBUS3	CTS#	D3	D3	TMS/CS
30	BDBUS4	DTR#	D4	D4	GPIOL0
32	BDBUS5	DSR#	D5	D5	GPIOL1
33	BDBUS6	DCD#	D6	D6	GPIOL2
34	BDBUS7	RI#/ TXDEN*	D7	D7	GPIOL3
Channel C					
38	CDBUS0	TXD	D0	D0	RS232 or Bit-Bang interface
39	CDBUS1	RXD	D1	D1	RS232 or Bit-Bang interface
40	CDBUS2	RTS#	D2	D2	RS232 or Bit-Bang interface
41	CDBUS3	CTS#	D3	D3	RS232 or Bit-Bang interface
43	CDBUS4	DTR#	D4	D4	RS232 or Bit-Bang interface
44	CDBUS5	DSR#	D5	D5	RS232 or Bit-Bang interface
45	CDBUS6	DCD#	D6	D6	RS232 or Bit-Bang interface
46	CDBUS7	RI#/ TXDEN*	D7	D7	RS232 or Bit-Bang interface
Channel D					
48	DDBUS0	TXD	D0	D0	RS232 or Bit-Bang interface
52	DDBUS1	RXD	D1	D1	RS232 or Bit-Bang interface
53	DDBUS2	RTS#	D2	D2	RS232 or Bit-Bang interface
54	DDBUS3	CTS#	D3	D3	RS232 or Bit-Bang interface
55	DDBUS4	DTR#	D4	D4	RS232 or Bit-Bang interface
57	DDBUS5	DSR#	D5	D5	RS232 or Bit-Bang interface
58	DDBUS6	DCD#	D6	D6	RS232 or Bit-Bang interface
59	DDBUS7	RI#/ TXDEN*	D7	D7	RS232 or Bit-Bang interface
60	PWREN#	PWREN#	PWREN#	PWREN#	PWREN#
36	SUSPEND#	SUSPEND#	SUSPEND#	SUSPEND#	SUSPEND#
Configuration memory interface					
63	EECS				
62	EECLK				
61	EEDATA				

Table 3.1 FT4232H Pin Configurations

* RI# or TXDEN is selectable in the EEPROM. Default is RI#.

3.3 Common Pins

The operation of the following FT4232H pins are the same regardless of the configured mode:-

Pin No.	Name	Type	Description
12,37,64	VCORE	POWER Input	+1.8V input. Core supply voltage input
20,31,42,56	VCCIO	POWER Input	+3.3V input. I/O interface power supply input. Failure to connect all VCCIO pins will result in failure of the device.
9	VPLL	POWER Input	+3.3V input. Internal PHY PLL power supply input. It is recommended that this supply is filtered using an LC filter.
4	VPHY	POWER Input	+3.3V Input. Internal USB PHY power supply input. Note that this cannot be connected directly to the USB supply. A +3.3V regulator must be used. It is recommended that this supply is filtered using an LC filter.
50	VREGIN	POWER Input	+3.3V Input. Integrated 1.8V voltage regulator input.
49	VREGOUT	POWER Output	+1.8V Output. Integrated voltage regulator output. Connect to VCORE with 3.3uF filter capacitor.
10	AGND	POWER Input	0V Analog ground.
1,5,11,15, 25,35,47,51	GND	POWER Input	0V Ground input.

Table 3.2 Power and Ground

Pin No.	Name	Type	Description
2	OSCI	INPUT	Oscillator input.
3	OSCO	OUTPUT	Oscillator output.
6	REF	INPUT	Current reference – connect via a 12K Ohm resistor @ 1% to GND.
7	DM	INPUT	USB Data Signal Minus.
8	DP	INPUT	USB Data Signal Plus.
13	TEST	INPUT	IC test pin – for normal operation should be connected to GND.
14	RESET#	INPUT	Reset input (active low).
60	PWREN#	OUTPUT	Active low power-enable output. PWREN# = 0: Normal operation. PWREN# = 1 : USB SUSPEND mode or device has not been configured. This can be used by external circuitry to power down logic when device is in USB suspend or has not been configured.
36	SUSPEND#	OUTPUT	Active low when USB is in suspend mode.

Table 3.3 Common Function pins

Pin No.	Name	Type	Description
63	EECS	I/O	EEPROM – Chip Select. Tri-State during device reset.
62	EECLK	OUTPUT	Clock signal to EEPROM. Tri-State during device reset. When not in reset, this outputs the EEPROM clock.
61	EEDATA	I/O	EEPROM – Data I/O Connect directly to Data-In of the EEPROM and to Data-Out of the EEPROM via a 2.2K resistor. Also, pull Data-Out of the EEPROM to VCC via a 10K resistor for correct operation. Tri-State during device reset.

Table 3.4 EEPROM Interface Group

3.4 Configured Pins

The following sections describe the function of the configurable pins referred to in Table 3.1 which is determined by how the FT4232H is configured.

3.4.1 FT4232H pins used as an asynchronous serial interface

The FT4232H any of the 4 channels can be configured as an asynchronous serial UART interface (RS232/422/485). When configured in this mode, the pins used and the descriptions of the signals are shown in Table 3.5.

Channel A Pin No.	Channel B Pin No.	Channel C Pin No.	Channel D Pin No.	Name	Type	RS232 Configuration Description
16	26	38	48	TXD	OUTPUT	TXD = transmitter output
17	27	39	52	RXD	INPUT	RXD = receiver input
18	28	40	53	RTS#	OUTPUT	RTS# = Ready To send handshake output
19	29	41	54	CTS#	INPUT	CTS# = Clear To Send handshake input
21	30	43	55	DTR#	OUTPUT	DTR# = Data Transmit Ready modem signaling line
22	32	44	57	DSR#	INPUT	DSR# = Data Set Ready modem signaling line
23	33	45	58	DCD#	INPUT	DCD# = Data Carrier Detect modem signaling line
24	34	46	59	RI#/ TXDEN	INPUT/OUTPUT	RI# = Ring Indicator Control Input. When the Remote Wake up option is enabled in the EEPROM, taking RI# low can be used to resume the PC USB Host controller from suspend. TXDEN = (TTL level). For use with RS485 level converters.

Table 3.5 Channel A,B,C and Channel D Asynchronous Serial Interface Configured Pin Descriptions

3.4.2 FT4232H pins used in a Synchronous or Asynchronous Bit-Bang Interface

The FT4232H channel A,B,C or channel D can be configured as a bit-bang interface. There are two types of bit-bang modes: synchronous and asynchronous.

When configured in any bit-bang mode (synchronous or asynchronous), the pins used and the descriptions of the signals are shown in **Table 3.6**

Channel Number	Pin Nos.	Name	Type	Synchronous or Asynchronous Bit-Bang Configuration Description
A	24,23,22,21, 19,18,17,16	ADBUS[7:0]	I/O	Channel A, D7 to D0 bidirectional bit-bang data
B	34,33,32,30, 29,28,27,26	BDBUS[7:0]	I/O	Channel B, D7 to D0 bidirectional bit-bang data
C	46,45,44,43, 41,40,39,38	CDBUS[7:0]	I/O	Channel C, D7 to D0 bidirectional bit-bang data
D	59,58,57,55 54,53,52,48	DDBUS[7:0]	I/O	Channel D, D7 to D0 bidirectional bit-bang data

Table 3.6 Channel A,B,C and Channel D Synchronous or Asynchronous Bit-Bang Configured Pin Descriptions

For a functional description of this mode, please refer to section 4.5 Synchronous and Asynchronous Bit-Bang Interface Mode Description.

3.4.3 FT4232H pins used in an MPSSE

The FT4232H channel A and channel B each have a Multi-Protocol Synchronous Serial Engine (MPSSE). Each MPSSE can be independently configured to a number of industry standard serial interface protocols such as JTAG, I2C or SPI, or it can be used to implement a proprietary bus protocol. For example, it is possible to use one of the FT4232H's channels (e.g. channel A) to connect to an SRAM configurable FPGA such as supplied by Altera or Xilinx. The FPGA device would normally be un-configured (i.e. have no defined function) at power-up. Application software on the PC could use the MPSSE to download configuration data to the FPGA over USB. This data would define the hardware function on power up. The other MPSSE channel (e.g. channel B) would be available for another serial interface function while channel C and channel D can be configured as UART or bit-bang mode. Alternatively each MPSSE can be used to control a number of GPIO pins. When configured in this mode, the pins used and the descriptions of the signals are shown in **Table 3.7**

Channel A Pin No.	Channel B Pin No.	Name	Type	MPSSE Configuration Description
16	26	TCK/SK	OUTPUT	Clock Signal Output. For example: JTAG – TCK, Test interface clock SPI – SK, Serial Clock
17	27	TDI/DO	OUTPUT	Serial Data Output. For example: JTAG – TDI, Test Data Input SPI – DO, serial data output
18	28	TDO/DI	INPUT	Serial Data Input. For example: JTAG – TDO, Test Data output SPI – DI, Serial Data Input
19	29	TMS/CS	OUTPUT	Output Signal Select. For example: JTAG – TMS, Test Mode Select SPI – CS, Serial Chip Select
21	30	GPIOL0	I/O	General Purpose input/output
22	32	GPIOL1	I/O	General Purpose input/output
23	33	GPIOL2	I/O	General Purpose input/output
24	34	GPIOL3	I/O	General Purpose input/output

Table 3.7 Channel A and Channel B MPSSE Configured Pin Descriptions

For a functional description of this mode, please refer to section 4.4.

When either Channel A or Channel B or both channels are used in MPSSE mode, Channel C and Channel D can be configured as asynchronous serial interface (RS232/422/485) or Bit-Bang mode or a combination of both.

4 Function Description

The FT4232H is FTDI's 5th generation of USB devices. The FT4232H is a USB 2.0 High Speed (480Mb/s) to UART/MPSSE ICs. It has the capability of being configured in a variety of industry standard serial interfaces.

The FT4232H has four independent configurable interfaces. Two of these interfaces can be configured as UART, JTAG, SPI, I2C or bit-bang mode, using an MPSSE, with independent baud rate generators. The remaining two interfaces can be configured as UART or bit-bang.

4.1 Key Features

USB High Speed to Quad Interface. The FT4232H is a USB 2.0 High Speed (480Mbits/s) to quad flexible/configurable serial interfaces.

Functional Integration. The FT4232H integrates a USB protocol engine which controls the physical Universal Transceiver Macrocell Interface (UTMI) and handles all aspects of the USB 2.0 High Speed interface. The FT4232H includes an integrated +1.8V Low Drop-Out (LDO) regulator and 12MHz to 480MHz PLL. It also includes 2kbytes Tx and Rx data buffers per channel. The FT4232H effectively integrates the entire USB protocol on a chip.

MPSSE. Multi-Purpose Synchronous Serial Engines (MPSSE), capable of speeds up to 30 Mbits/s, provides flexible synchronous interface configurations.

Data Transfer rate. The FT4232H supports a data transfer rate up to 12 Mbit/s when configured as an RS232/RS422/RS485 UART interface.

Latency Timer. This is really a feature of the driver and is used to as a timeout to flush short packets of data back to the PC. The default is 16ms, but it can be altered between 0ms and 256ms. At 0ms latency you get a packet transfer on every high speed microframe.

4.2 Functional Block Descriptions

Quad Multi-Purpose UART/MPSSE Controllers. The FT4232H has four independent UART/MPSSE Controllers. These blocks control the UART data or control the Bit-Bang mode if selected by the SETUP command. The blocks used on channel A and channel B also contain a MPSSE (Multi Protocol Synchronous Serial Engine) in each of them which can be used independently of each other and the remaining UART channels. Using this it can be configured under software command to have 1 MPSSE + 3 UARTS (each UART can be set to Bit Bang mode to gain extra I/O if required) or 2 MPSSE + 2 UARTS.

USB Protocol Engine and FIFO control. The USB Protocol Engine controls and manages the interface between the UTMI PHY and the FIFOs of the chip. It also handles power management and the USB protocol specification.

Dual Port FIFO TX Buffer (2Kbytes per channel). Data from the Host PC is stored in these buffers to be used by the Multi-purpose UART/FIFO controllers. This is controlled by the USB Protocol Engine and FIFO control block.

Dual Port FIFO RX Buffer (2Kbytes per channel). Data from the Multi-purpose UART/FIFO controllers is stored in these blocks to be sent back to the Host PC when requested. This is controlled by the USB Protocol Engine and FIFO control block.

RESET Generator - The integrated Reset Generator Cell provides a reliable power-on reset to the device internal circuitry at power up. The RESET# input pin allows an external device to reset the FT4232H. RESET# should be tied to VCCIO (+3.3v) if not being used.

Independent Baud Rate Generators - The Baud Rate Generators provides a x16 or a x10 clock input to the UART's from a 120MHz reference clock and consists of a 14 bit pre-scaler and 4 register bits which provide fine tuning of the baud rate (used to divide by a number plus a fraction). This determines the Baud Rate of the UART which is programmable from 183 baud to 12 million baud.

See FTDI application note AN232B-05 on the FTDI website (www.ftdichip.com) for more details.

+1.8V LDO Regulator. The +1.8V LDO regulator generates the +1.8 volts for the core and the USB transceiver cell. Its input (VREGIN) must be connected to a +3.3V external power source. It is also recommended to add an external filtering capacitor to the VREGIN. There is no direct connection from the +1.8V output (VREGOUT) and the internal functions of the FT4232H. The PCB must be routed to connect VREGOUT to the pins that require the +1.8V including VREGIN.

UTMI PHY. The Universal Transceiver Macrocell Interface (UTMI) physical interface cell. This block handles the Full speed / High Speed SERDES (serialise - deserialise) function for the USB TX/RX data. It also provides the clocks for the rest of the chip. A 12 MHz crystal should be connected to the OSCI and OSCO pins. A 12K Ohm resistor should be connected between REF and GND on the PCB.

The UTMI PHY functions include:

- Supports 480 Mbit/s "High Speed" (HS)/ 12 Mbit/s "Full Speed" (FS), FS Only and "Low Speed" (LS).
- SYNC/EOP generation and checking.
- Data and clock recovery from serial stream on the USB.
- Bit-stuffing/unstuffing; bit stuff error detection.
- Manages USB Resume, Wake Up and Suspend functions.
- Single parallel data clock output with on-chip PLL to generate higher speed serial data clocks.

EEPROM Interface. When used without an external EEPROM the FT4232H defaults to a quad USB to an asynchronous serial port device. Adding an external 93C46 (93C56 or 93C66) EEPROM allows each of the chip's channels to be independently configured as a serial UART (RS232 mode), bit-bang mode or fast serial (opto isolation). The external EEPROM can also be used to customise the USB VID, PID, Serial Number, Product Description Strings and Power Descriptor value of the FT4232H for OEM applications. Other parameters controlled by the EEPROM include Remote Wake Up, Soft Pull Down on Power-Off and I/O pin drive strength.

The EEPROM must be a 16 bit wide configuration such as a Microchip 93LC46B or equivalent capable of a 1Mbit/s clock rate at VCC = +3.00V to 3.6V. The EEPROM is programmable in-circuit over USB using a utility program called MPROG available from FTDI's web site (www.ftdichip.com). This allows a blank part to be soldered onto the PCB and programmed as part of the manufacturing and test process.

If no EEPROM is connected (or the EEPROM is blank), the FT4232H will default to serial ports. The device uses its built-in default VID (0403), PID (6011) Product Description and Power Descriptor Value. In this case, the device will not have a serial number as part of the USB descriptor.

4.3 FT232 UART Interface Mode Description

The FT4232H can be configured in similar UART modes as the FTDI FT232 devices (an asynchronous serial interface). The following examples illustrate how to configure the FT4232H with an RS232, RS422 or RS485 interfaces. The FT4232 can be configured as a mixture of these interfaces.

4.3.1 RS232 Configuration

Figure 4.1 illustrates how the FT4232H channel A can be configured with an RS232 UART interface. This can be repeated for channels B, C and D to provide a quad RS232, but has been omitted for clarity.

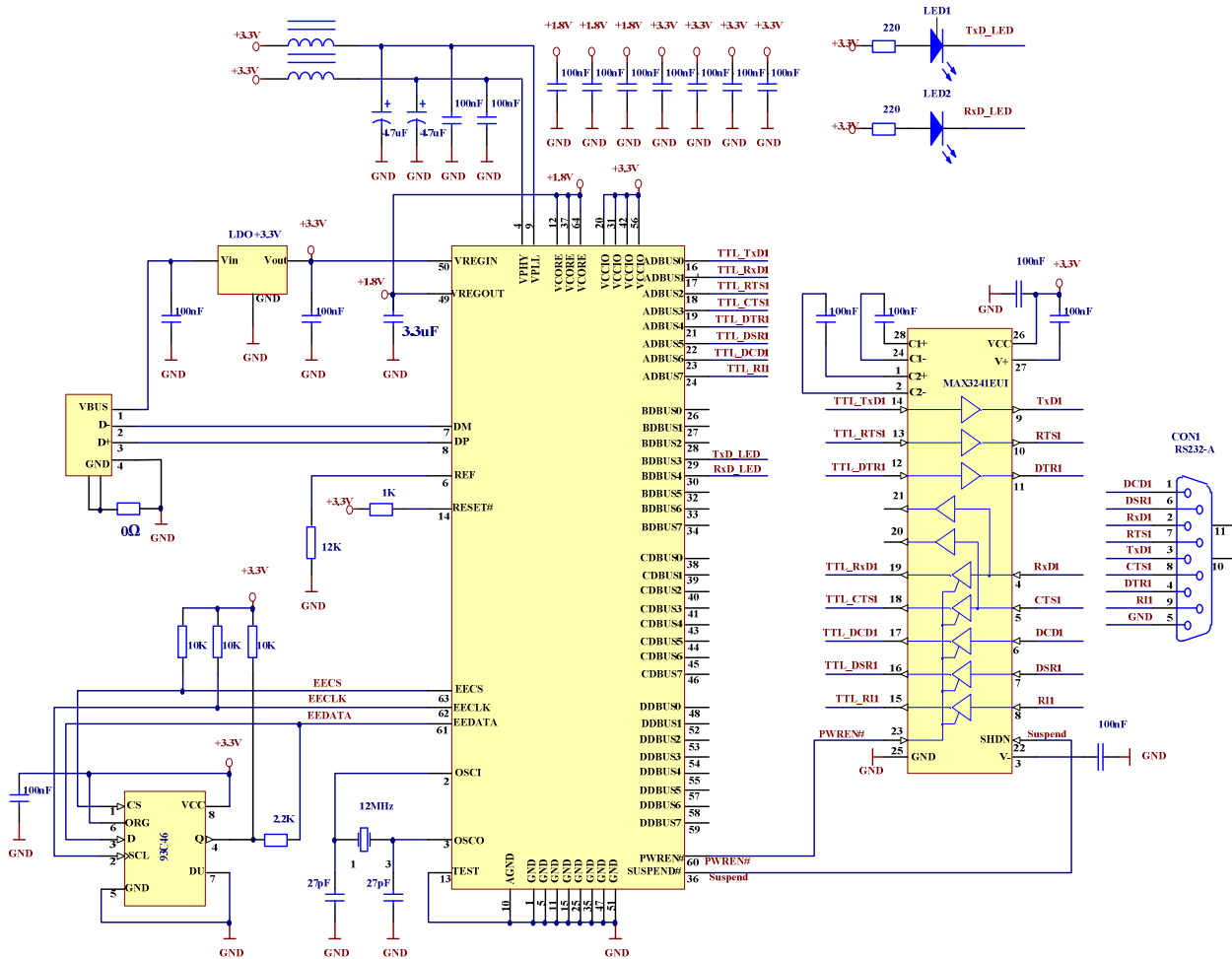

Figure 4.1 RS232 Configuration

4.3.2 RS422 Configuration

Figure 4.2 illustrates how the FT4232H can be configured as a dual RS422 interface. The FT4232H can have all 4 channels connected as RS422, but only channel A and channel C are shown for clarity.

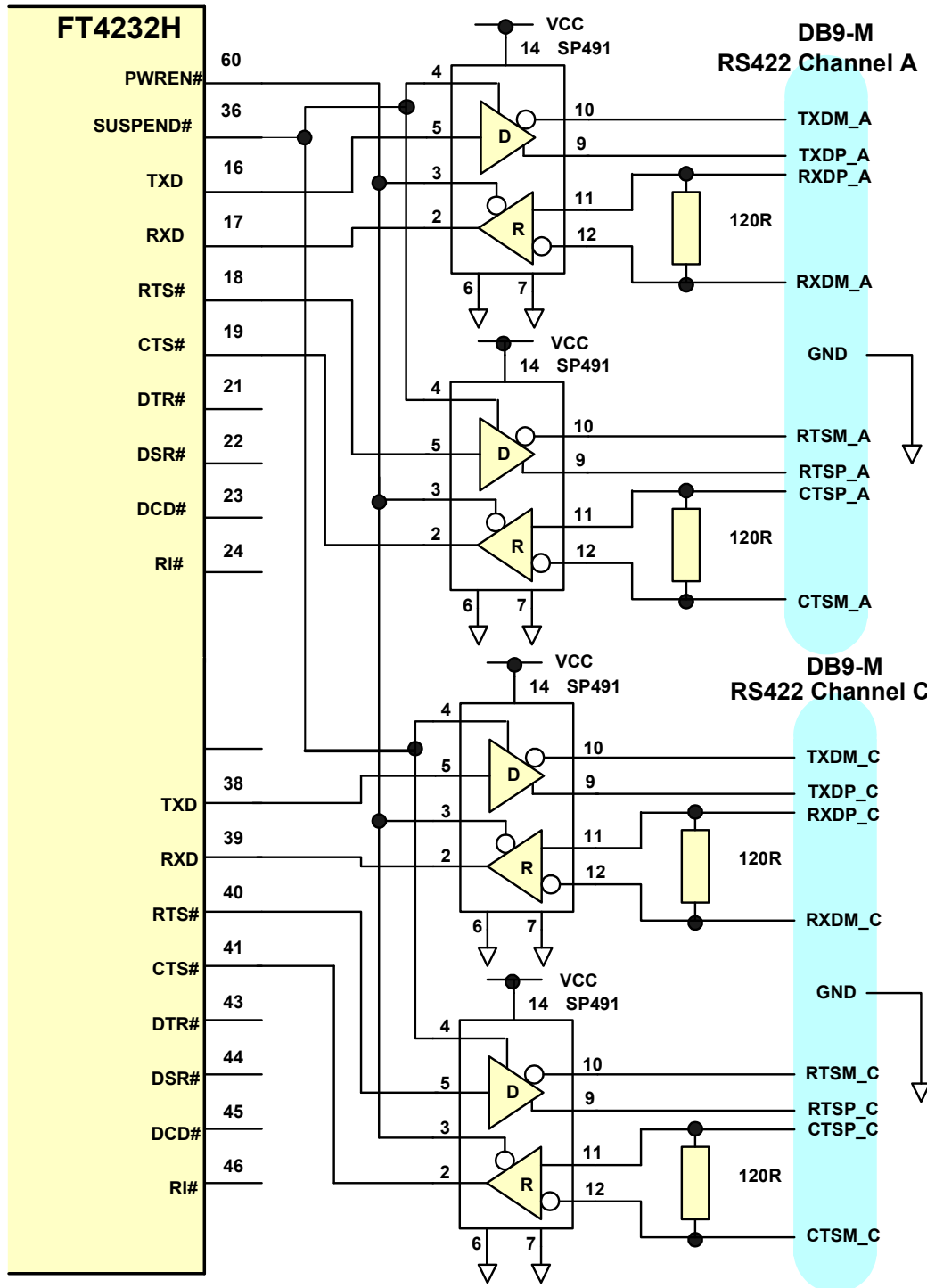

Figure 4.2 Dual RS422 Configuration

In this case both channel A and channel C are configured as UART operating at TTL levels. The Sipex SP491 is used as a level converter to convert the TTL level signals from the FT4232H to RS422 levels. The PWREN# signal is used to power down the level shifters such that they operate in a low quiescent current when the USB interface is in suspend mode.

4.3.3 RS485 Configuration

Figure 4.3 illustrates how the FT4232H can be configured as a dual RS485 interface. The FT4232H can have all 4 channels connected as RS485, but only channel A and channel C are shown for clarity.

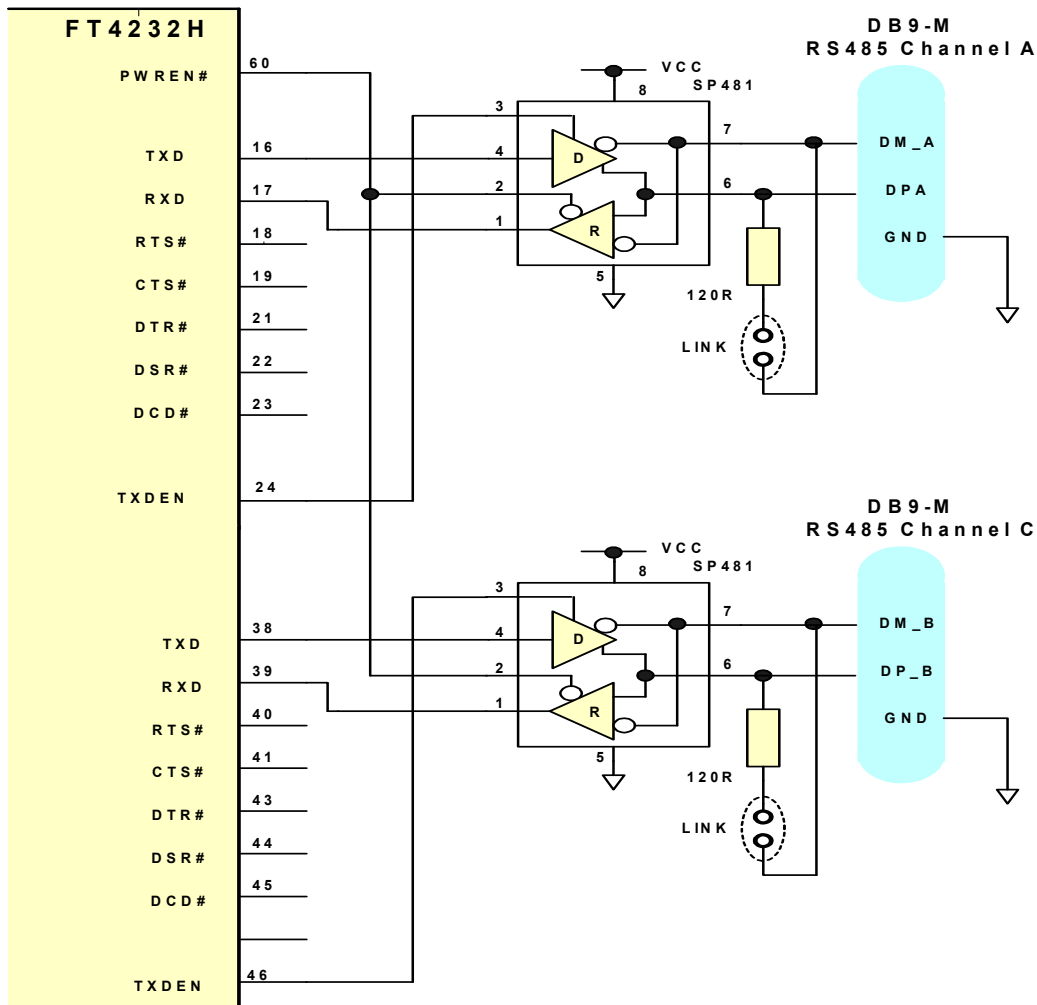

Figure 4.3 Dual RS485 Configuration

In this case both channel A and channel C are configured as RS485 operating at TTL levels. This example uses two Sipex SP491 devices but there are similar parts available from Maxim and Analog Devices amongst others. The SP491 is a RS485 device in a compact 8 pin SOP package. It has separate enables on both the transmitter and receiver. With RS485, the transmitter is only enabled when a character is being transmitted from the UART. The TXDEN pins on the FT4232H are provided for exactly that purpose, and so the transmitter enables are wired to the TXDEN's. The receiver enable is active low, so it is wired to the PWREN# pin to disable the receiver when in USB suspend mode.

RS485 is a multi-drop network – i.e. many devices can communicate with each other over a single two wire cable connection. The RS485 cable requires to be terminated at each end of the cable. Links are provided to allow the cable to be terminated if the device is physically positioned at either end of the cable.

In this example the data transmitted by the FT4232H is also received by the device that is transmitting. This is a common feature of RS485 and requires the application software to remove the transmitted data from the received data stream. With the FT4232H it is possible to do this entirely in hardware – simply modify the schematic so that RXD of the FT4232H is the logical OR of the SP481 receiver output with TXDEN using an HC32 or similar logic gate.

4.4 MPSSSE Interface Mode Description.

MPSSSE Mode is designed to allow the FT4232H to interface efficiently with synchronous serial protocols such as JTAG, I2C and SPI Bus. It can also be used to program SRAM based FPGA's over USB. The MPSSSE interface is designed to be flexible so that it can be configured to allow any synchronous serial protocol (industry standard or proprietary) to be implemented using the FT4232H. MPSSSE is only available on channel A and channel B.

MPSSSE is fully configurable, and is programmed by sending commands down the data stream. These can be sent individually or more efficiently in packets. MPSSSE is capable of a maximum sustained data rate of 30 Mbits/s.

When a channel is configured in MPSSSE mode, the IO timing and signals used are shown in Figure 4.4 and Table 4.1. These show timings for CLKOUT=30MHz. CLKOUT can be divided internally to be provide a slower clock.

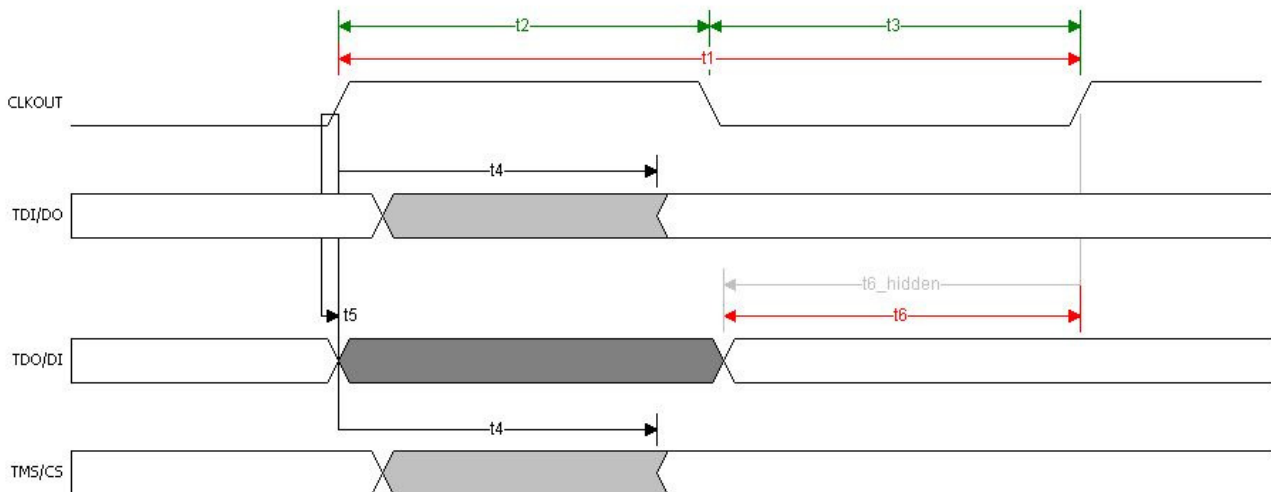

Figure 4.4 MPSSSE Signal Waveforms

NAME	MIN	NOM	MAX	Units	COMMENT
t1		33.33		ns	CLKOUT period
t2	15	16.67		ns	CLKOUT high period
t3	15	16.67		ns	CLKOUT low period
t4	1		7.15	ns	CLKOUT to TDI/DO delay
t5	0			ns	TDO/DI hold time
t6	11				TDO/DI setup time

Table 4.1 MPSSSE Signal Timings

MPSSSE mode is enabled using Set Bit Bang Mode driver command. A hex value of 2 will enable it, and a hex value of 0 will reset the device. See application note **AN2232L-02, “Bit Mode Functions for the FT2232D”** for more details and examples.

The MPSSSE command set is fully described in application note **AN_108 – “Command Processor For MPSSSE and MCU Host Bus Emulation Modes”**.

The following additional application notes are available for configuring the MPSSSE :

- **AN_109 – “Programming Guide for High Speed FTCI2C DLL”**
- **AN_110 – “Programming Guide for High Speed FTCJTAG DLL”**
- **AN_111 – “Programming Guide for High Speed FTCSPI DLL”**

4.4.1 MPSSE Adaptive Clocking

Adaptive clocking is a new MPSSE feature added to the FT4232H MPSSE engine.

The mode is effectively handshaking the CLK signal with a return clock RTCK. This is a technique used by ARM processors.

The FT4232H will assert the CLK line and wait for the RTCK to be returned from the target device to GPIOL3 line before changing the TDO (data out line).

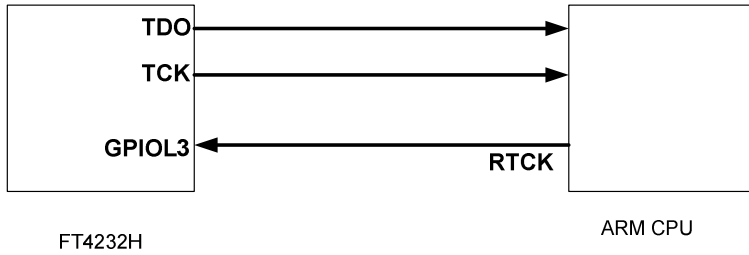

Figure 4.5 Adaptive Clocking Interconnect

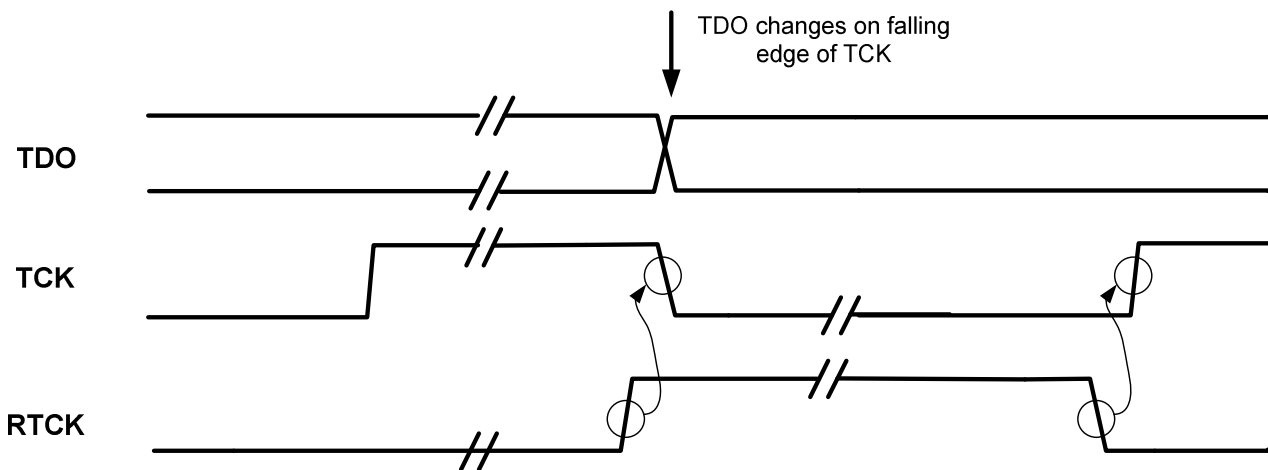

Figure 4.6: Adaptive Clocking waveform.

Adaptive clocking is not enabled by default.

See: AN_108 Command Processor for MPSSE and MCU Host Bus Emulation Modes.

4.5 Synchronous and Asynchronous Bit-Bang Interface Mode Description

The FT4232H channel A,B,C or channel D can be configured as a bit-bang interface. There are two types of bit-bang modes: synchronous and asynchronous.

Asynchronous Bit-Bang Mode

Asynchronous Bit-Bang mode is the same as BM-style Bit-Bang mode. On any channel configured in asynchronous bit-bang mode, data written to the device in the normal manner will be self clocked onto the parallel I/O data pins (those which have been configured as outputs). Each I/O pin can be independently set as an input or an output. The rate that the data is clocked out at is controlled by the baud rate generator.

For the data to change there has to be new data written, and the baud rate clock has to tick. If no new data is written to the channel, the pins will hold the last value written.

Synchronous Bit-Bang Mode

The synchronous Bit-Bang mode will only update the output parallel I/O port pins whenever data is sent from the USB interface to the parallel interface. When this is done, data is read from the USB Rx FIFO buffer and written out on the pins. Data can only be received from the parallel pins (to the USB Tx FIFO interface) when the parallel interface has been written to.

With Synchronous Bit-Bang mode, data will only be sent out by the FT4232H if there is space in the FT4232H USB TXFIFO for data to be read from the parallel interface pins. This Synchronous Bit-Bang mode will read the data bus parallel I/O pins first, before it transmits data from the USB Rx FIFO. It is therefore 1 byte behind the output, and so to read the inputs for the byte that you have just sent, another byte must be sent.

For example :-

(1) Pins start at 0xFF
Send 0x55,0xAA
Pins go to 0x55 and then to 0xAA
Data read = 0xFF,0x55

(2) Pins start at 0xFF
Send 0x55,0xAA,0xAA
(repeat the last byte sent)
Pins go to 0x55 and then to 0xAA
Data read = 0xFF,0x55,0xAA

Synchronous Bit-Bang Mode differs from Asynchronous Bit-Bang mode in that the device parallel output is only read when the parallel output is written to by the USB interface. This makes it easier for the controlling program to measure the response to a USB output stimulus as the data returned to the USB interface is synchronous to the output data.

Asynchronous Bit-Bang mode is enabled using Set Bit Bang Mode driver command. A hex value of 1 will enable Asynchronous Bit-Bang mode.

Synchronous Bit-Bang mode is enabled using Set Bit Bang Mode driver command. A hex value of 4 will enable Synchronous Bit-Bang mode.

See application note **AN2232-02**, “**Bit Mode Functions for the FT2232**” for more details and examples of using the bit-bang modes.

An example of the synchronous bi-bang mode timing is shown in Figure 4.7 and Table 4.2.

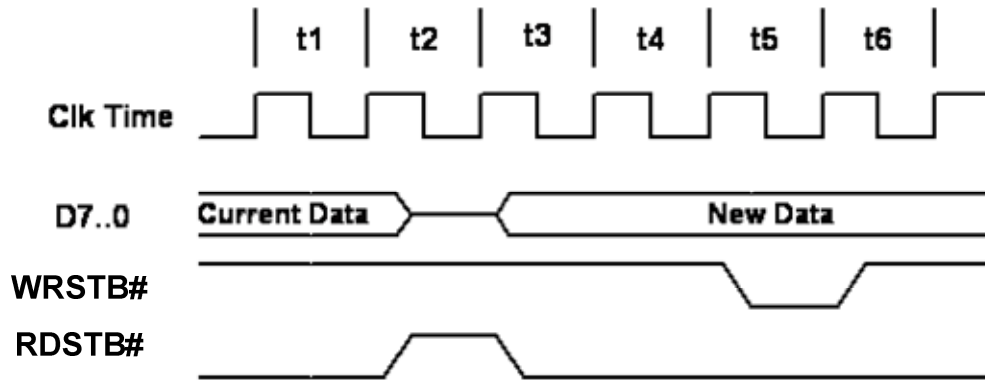

Figure 4.7 Synchronous Bit-Bang Mode Timing Interface Example

It should be noted that the FT4232H does not output the WRSTB# or RDSTB# signals when configured in bit-bang mode. Figure 4.7. and Table 4.2 show these signals for **illustration** purposes only.

NAME	Description
t1	Current pin state is read
t2	RDSTB# is set inactive and data on the parallel I/O pins is read and sent to the USB host.
t3	RDSTB# is set active again, and any pins that are output will change to their new data
t4	1 clock cycle to allow for data setup
t5	WRSTB# goes active. This indicates that the host PC has written new data to the I/O parallel data
t6	WRSTB# goes inactive

Table 4.2 Synchronous Bit-Bang Mode Timing Interface Example Timings

WRSTB# = this output indicates when new data has been written to the I/O pins from the Host PC (via the USB interface).

RDSTB# = this output rising edge indicates when data has been read from the I/O pins and sent to the Host PC (via the USB interface).

4.6 FT4232H Mode Selection

The 4 channels of the FT4232H reset to 4 asynchronous serial UART interfaces. Following a reset, the required mode can be configured by sending the **FT_SetBitMode** command (refer to *D2XX_Programmers_Guide*) to the USB driver software.

The EEPROM contents have no effect on the selected mode with the exception of selecting the TXDEN for RS485 mode when asynchronous serial interface has been selected in software. If the device is reset, then the 4 channels must be reconfigured into the required mode.

Note that the mode of each of the 4 channels is independent of the other channels.

The MPSSE can be configured directly using the D2XX commands. The *D2XX_Programmers_Guide* is available from the FTDI website at [http://www.ftdichip.com/Documents/ProgramGuides/D2XX_Programmer's_Guide\(FT_000071\).pdf](http://www.ftdichip.com/Documents/ProgramGuides/D2XX_Programmer's_Guide(FT_000071).pdf)

Also the MPSSE command set is fully described in application note **AN_108 – “Command Processor For MPSSE and MCU Host Bus Emulation Modes”**.

5 Devices Characteristics and Ratings

5.1 Absolute Maximum Ratings

The absolute maximum ratings for the FT4232H devices are as follows. These are in accordance with the Absolute Maximum Rating System (IEC 60134). Exceeding these values may cause permanent damage to the device.

Parameter	Value	Unit
Storage Temperature	-65°C to 150°C	Degrees C
Floor Life (Out of Bag) At Factory Ambient (30°C / 60% Relative Humidity)	168 Hours (IPC/JEDEC J-STD-033A MSL Level 3 Compliant)*	Hours
Ambient Operating Temperature (Power Applied)	-40°C to 85°C	Degrees C
MTTF FT4232HL	TBD	hours
MTTF FT4232HQ	TBD	hours
V _{CORE} Supply Voltage	-0.3 to +2.0	V
V _{CCIO} IO Voltage	-0.3 to +4.0	V
DC Input Voltage – USB _{DP} and USB _{DM}	-0.5 to +3.63	V
DC Input Voltage – High Impedance Bi-directionals (powered from V _{CCIO})	-0.3 to +5.8	V
DC Input Voltage – All Other Inputs	-0.5 to + (V _{CCIO} +0.5)	V
DC Output Current – Outputs	16	mA

Table 5.1 Absolute Maximum Ratings

* If devices are stored out of the packaging beyond this time limit the devices should be baked before use. The devices should be ramped up to a temperature of +125°C and baked for up to 17 hours.

5.2 DC Characteristics

DC Characteristics (Ambient Temperature = -40°C to +85°C)

Parameter	Description	Minimum	Typical	Maximum	Units	Conditions
V _{CORE}	VCC Core Operating Supply Voltage	1.62	1.80	1.98	V	
V _{CICIO*}	VCCIO Operating Supply Voltage	2.97	3.30	3.63	V	Cells are 5V tolerant
V _{REGIN}	VREGIN Voltage regulator Input	3.00	3.30	3.60	V	
V _{REGOUT}	Voltage regulator Output	1.71	1.80	1.89	V	
I _{reg}	Regulator Current			150	mA	V _{REGIN} +3.3V
I _{cc1}	Core Operating Supply Current	---	70	---	mA	V _{CORE} = +1.8V Normal Operation
I _{cc1r}	Core Reset Supply Current	---	5	---	mA	V _{CORE} = +1.8V Device in reset state.
I _{cc1s}	Core Suspend Supply Current		500		μA	V _{CORE} = +1.8V USB Suspend

Table 5.2 Operating Voltage and Current

*NOTE: Failure to connect all VCCIO pins will result in failure of the device.

The I/O pins are +3.3v cells, which are +5V tolerant (except the USB PHY pins).

Parameter	Description	Minimum	Typical	Maximum	Units	Conditions
Voh	Output Voltage High	2.40	3.14		V	Ioh = +/-2mA I/O Drive strength* = 4mA
			3.20		V	I/O Drive strength* = 8mA
			3.22		V	I/O Drive strength* = 12mA
			3.22		V	I/O Drive strength* = 16mA
Vol	Output Voltage Low		0.18	0.40	V	Iol = +/-2mA I/O Drive strength* = 4mA
			0.12		V	I/O Drive strength* = 8mA
			0.08		V	I/O Drive strength* = 12mA
			0.07		V	I/O Drive strength* = 16mA
Vil	Input low Switching Threshold		-	0.80	V	LVTTL
Vih	Input High Switching Threshold	2.0	-		V	LVTTL
Vt	Switching Threshold		1.50		V	LVTTL
Vt-	Schmitt trigger negative going threshold voltage	0.80	1.10	-	V	
Vt+	Schmitt trigger positive going threshold voltage		1.60	2.0	V	
R _{pu}	Input pull-up resistance	40	75	190	KΩ	Vin = 0
R _{pd}	Input pull-down resistance	40	75	190	KΩ	Vin = VCCIO
I _{in}	Input Leakage Current	15	45	85	μA	Vin = 0
I _{oz}	Tri-state output leakage current		+/-10		μA	Vin = 5.5V or 0

Table 5.3 I/O Pin Characteristics (except USB PHY pins)

*The I/O drive strength and slow slew-rate are configurable in the EEPROM.

DC Characteristics (Ambient Temperature = -40°C to +85°C)

Parameter	Description	Minimum	Typical	Maximum	Units	Conditions
VPHY, VPLL	PHY Operating Supply Voltage	3.0	3.3	3.6	V	3.3V I/O
Iccphy	PHY Operating Supply Current	---	30	60	mA	High-speed operation at 480 MHz
Iccphy (susp)	PHY Operating Supply Current	---	10	50	μA	USB Suspend

Table 5.4 PHY Operating Voltage and Current

Parameter	Description	Minimum	Typical	Maximum	Units	Conditions
Voh	Output Voltage High	V _{CORE} -0.2			V	
Vol	Output Voltage Low			0.2	V	
Vil	Input low Switching Threshold		-	0.8	V	
Vih	Input High Switching Threshold	2.0	-		V	

Table 5.5 PHY I/O Pin Characteristics

6 FT4232H Configurations

The following sections illustrate possible USB power configurations for the FT4232H.

All USB power configurations illustrated apply to both package options for the FT4232H device

6.1 USB Bus Powered Configuration

Bus Powered Application example 1: Bus powered configuration

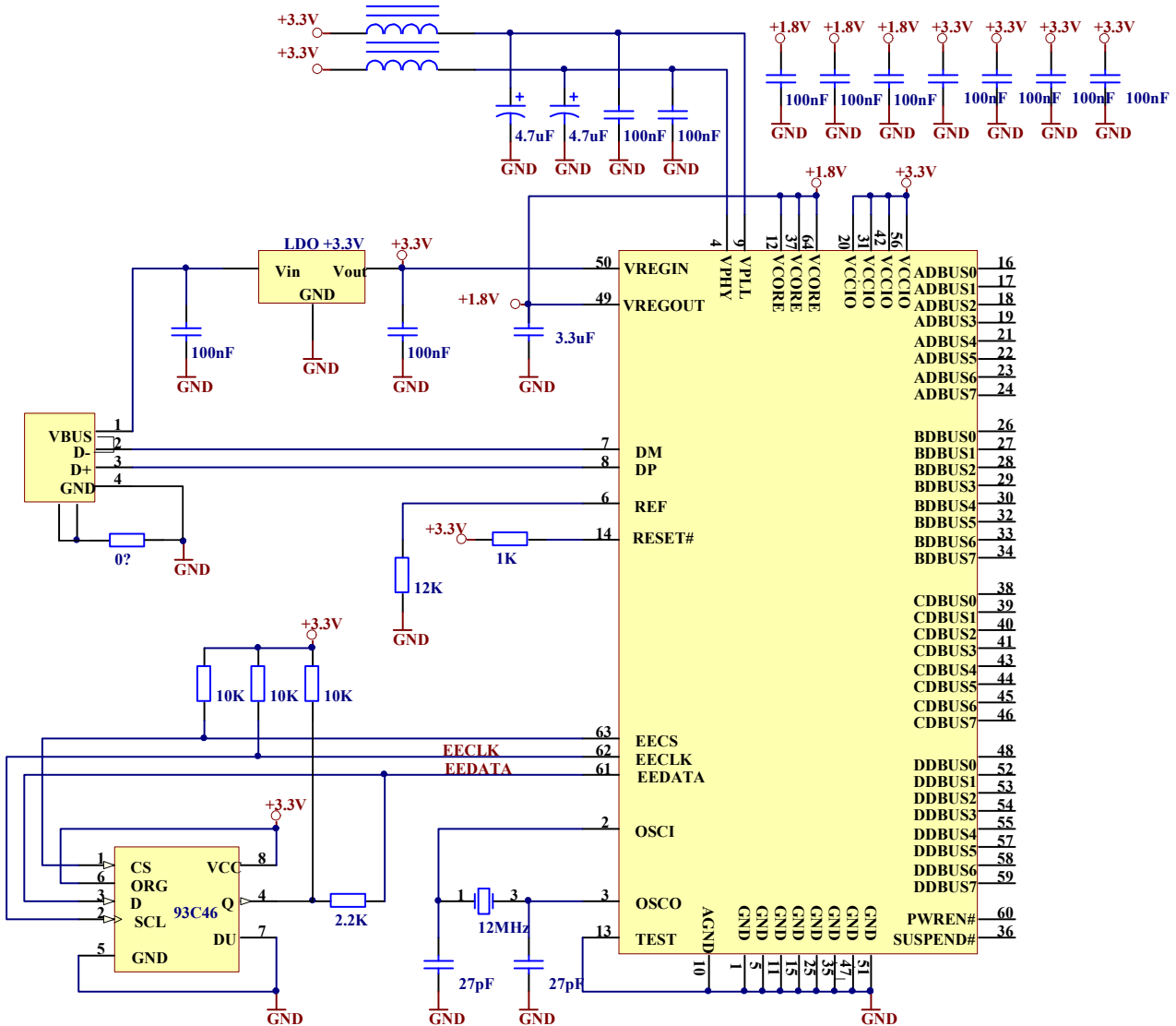

Figure 6.1 Bus Powered Configuration Example 1

Figure 6.1 illustrates the FT4232H in a typical USB bus powered design configuration. A USB bus powered device gets its power from the USB bus. In this application, the FT4232H requires that the VBUS (USB +5V) is regulated down to +3.3V (using an LDO) to supply the VCCIO, VPLL, VPHY and VREGIN.

VREGIN is the +3.3V input to the on chip +1.8V regulator. The output of the on chip LDO regulator (+1.8V) drives the FT4232H core supply (VCORE). This requires a minimum of a 3.3uF filter capacitor.

Bus Powered Application example 2: Bus powered configuration (with additional 1.8V LDO voltage regulator for VCORE)

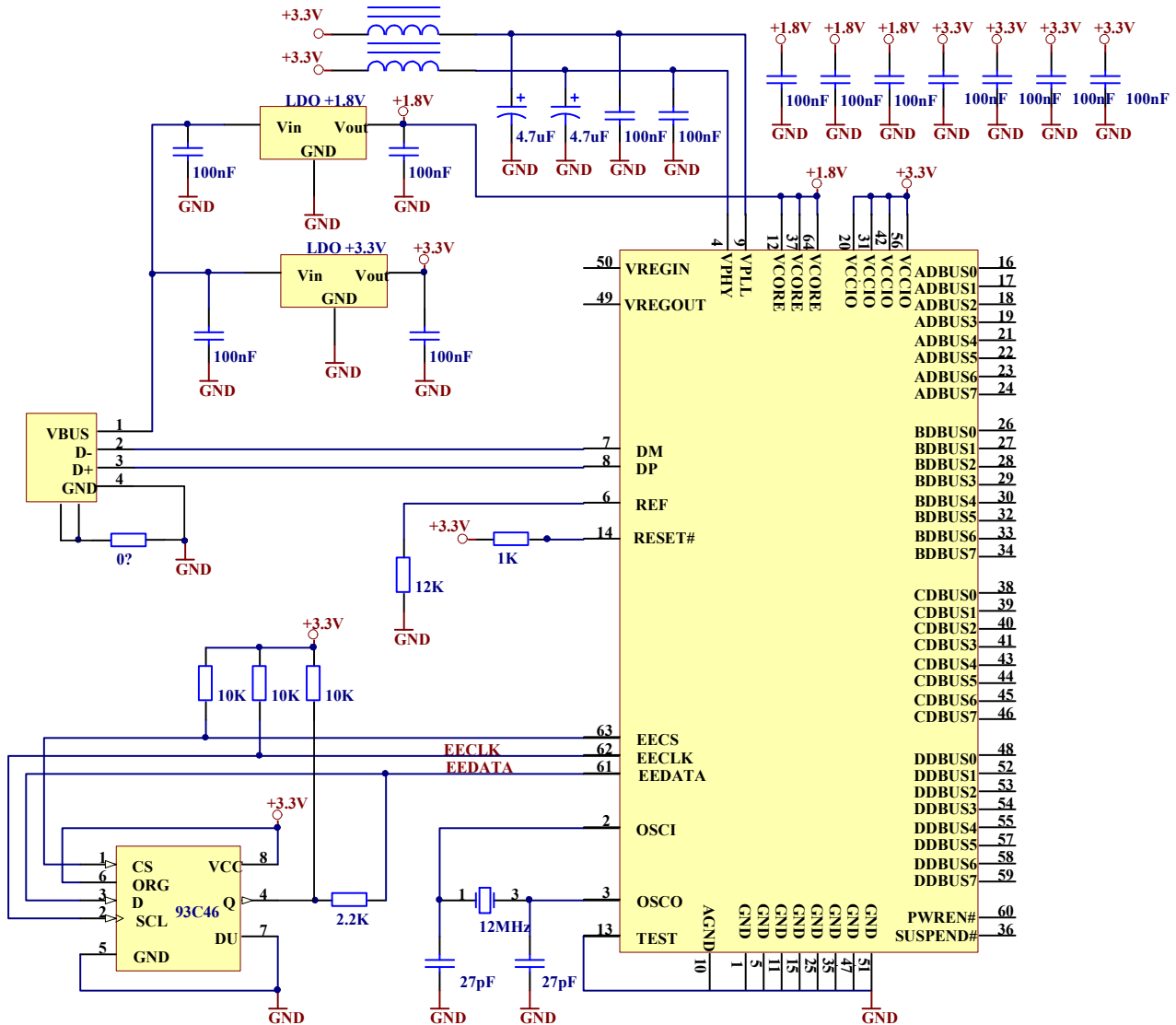

Figure 6.2 Bus Powered Configuration Example 2

Figure 6.3 illustrates the FT4232H in a typical USB bus powered configuration similar to Figure 6.1. The difference here is that the +1.8V for the FT4232H core (VCORE) has been regulated from the VBUS as well as the +3.3V supply to the VPLL, VPHY, VCCIO and VREGIN.

Self Powered application example 2: Self powered configuration (with additional 1.8V LDO voltage regulator for VCORE)

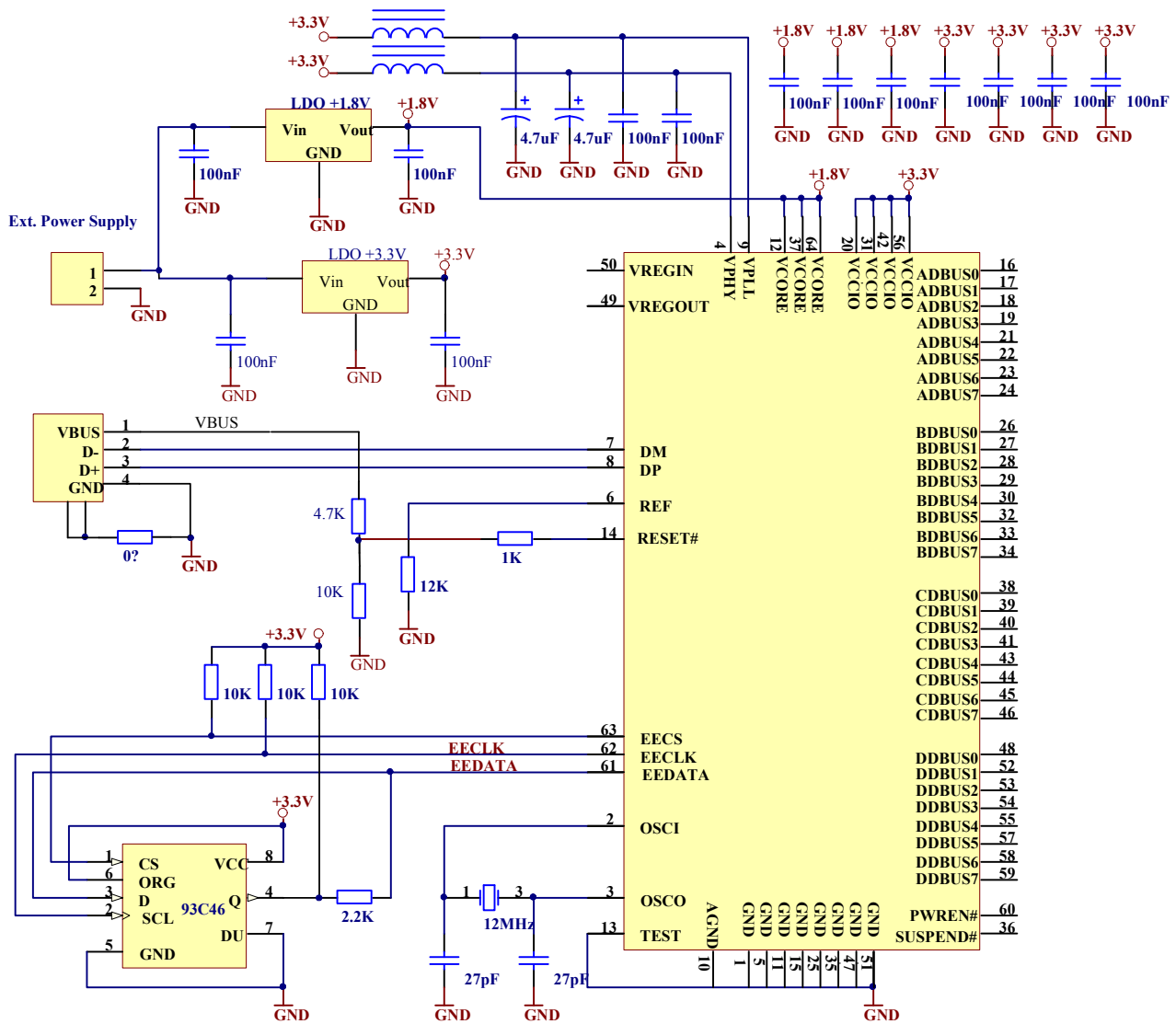

Figure 6.4 Self Powered Configuration Example 2

Figure 6.4 illustrates the FT4232H in a typical USB self powered configuration similar to Figure 6.3. The difference here is that the +1.8V for the FT4232H core has been regulated from the external power supply.

Note that in this set-up, the EEPROM should be configured for self-powered operation.

6.3 Oscillator Configuration

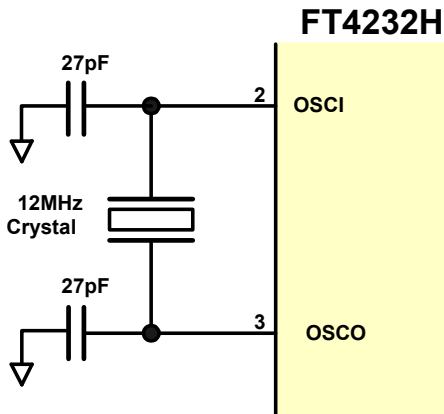

Figure 6.5 Recommended FT4232H Crystal Oscillator Configuration.

Figure 6.5 illustrates how to connect the FT4232H with a 12MHz $\pm 0.003\%$ crystal. In this case loading capacitors should be added between OSCI, OSCO and GND as shown. A value of 27pF is shown as the capacitor in the example – this will be good for many crystals but it is recommended to select the loading capacitor value based on the manufacturer’s recommendations wherever possible. It is recommended to use a parallel cut type crystal.

It is also possible to use a 12 MHz oscillator with the FT4232H. In this case the output of the oscillator would drive OSCI, and OSCO should be left unconnected. The oscillator must have a CMOS output drive capability.

Parameter	Description	Minimum	Typical	Maximum	Units	Conditions
OSCI Vin	Input Voltage	2.97	3.30	3.63	V	
FIn	Input Frequency		12		MHz	+/- 30ppm
Ji	Cycle to cycle jitter		< 150		pS	

Table 6.1 OSCI Input characteristics

6.4 4 Channel Transmit and Receiver LED Indication Example

The following example illustrates how a 74HCT595 can be used to decode the EEDATA data to indicate Tx and Rx on each of the channels. The associated LED will light when the Channel is transmitting or receiving data.

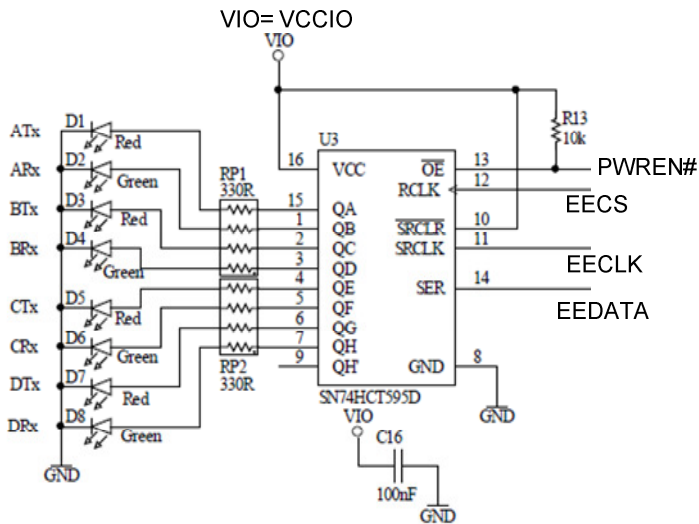

Figure 6.6 Using 74HCT595 to Indicate Tx and Rx Data

In this configuration, the LEDs will flash when the EEPROM is accessed. For example during enumeration. Under normal operation, the EECS is held low to disable access to the EEPROM. In this special case, the EECLK will clock the EEDATA into the 74HCT595 shift register (with EECS low, therefore EEPROM ignores the EEDATA). Then EECS will pulse high. The rising edge of the EECS latches the data into a storage register of the 74HCT595 which drives the LEDs.

Please refer to the 74HCT595 datasheet for further explanation.



7 EEPROM Configuration

If an external EEPROM is fitted (93LC46/56/66) it can be programmed over USB using MPROG V3.4a or later. The EEPROM must be 16 bits wide and capable of working at a VCC supply of +3.0 to +3.6 volts.



8 Package Parameters

The FT4232H is available in two different packages. The FT4232HL is the LQFP-64 option and the FT4232HQ is the QFN-64 package option. The solder reflow profile for both packages is described in Section 8.3

8.1 FT4232HQ, QFN-64 Package Dimensions

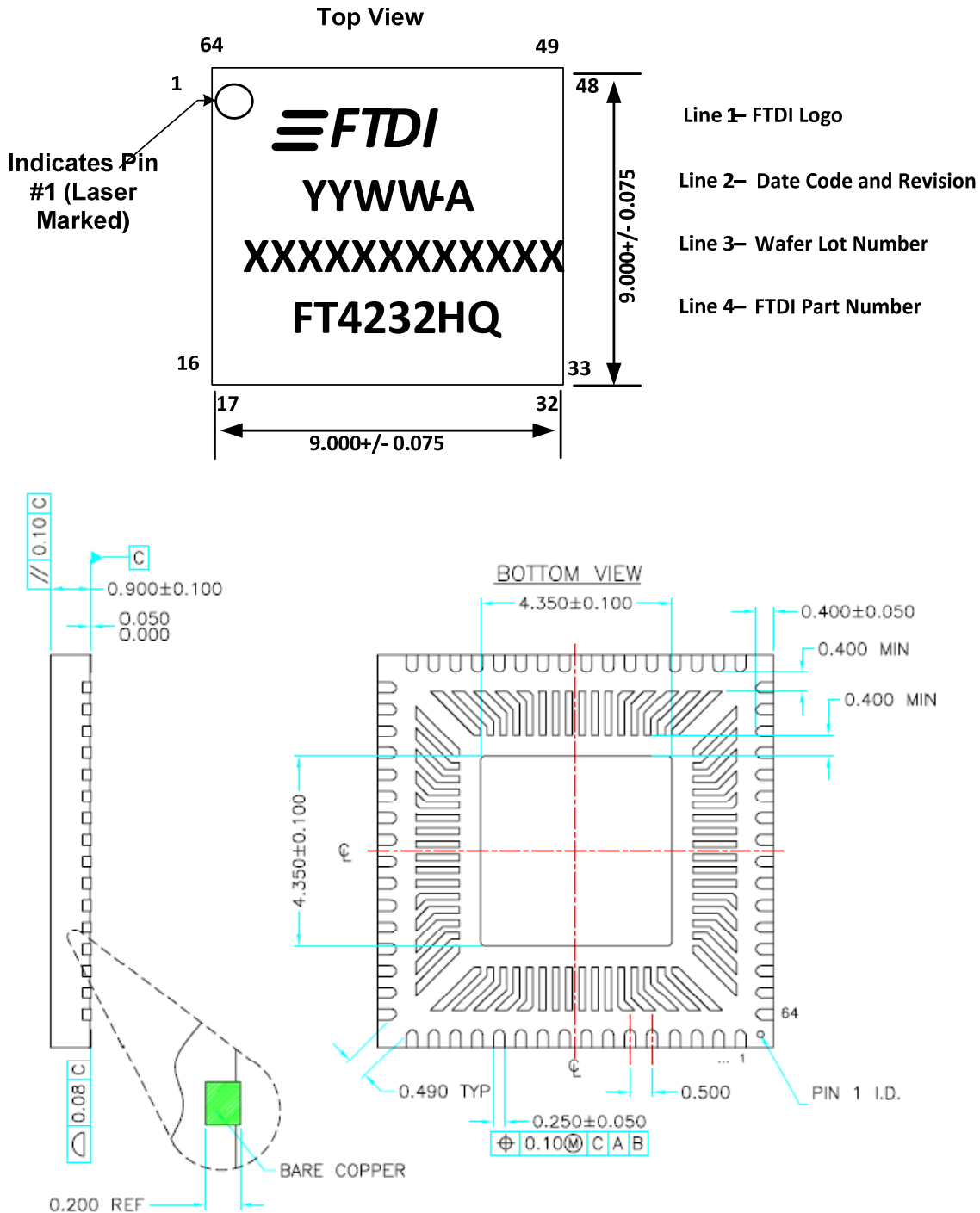

Notes

1. All dimensions are in mm.
2. Pin 1 ID can be combination of DOT AND/OR Chamfer.
3. Pin 1 ID is NOT connected to the internal ground of the device. It is internally connected to the bottom side central solder pad, which is 4.35 x 4.35mm.
4. Pin 1 ID can be connected to system ground, but it is not recommended using this as a ground point for the device.
5. Optional Chamfer on corner leads.

Figure 8.1 64 pin QFN Package Details

8.2 FT4232HL, LQFP-64 Package Dimensions

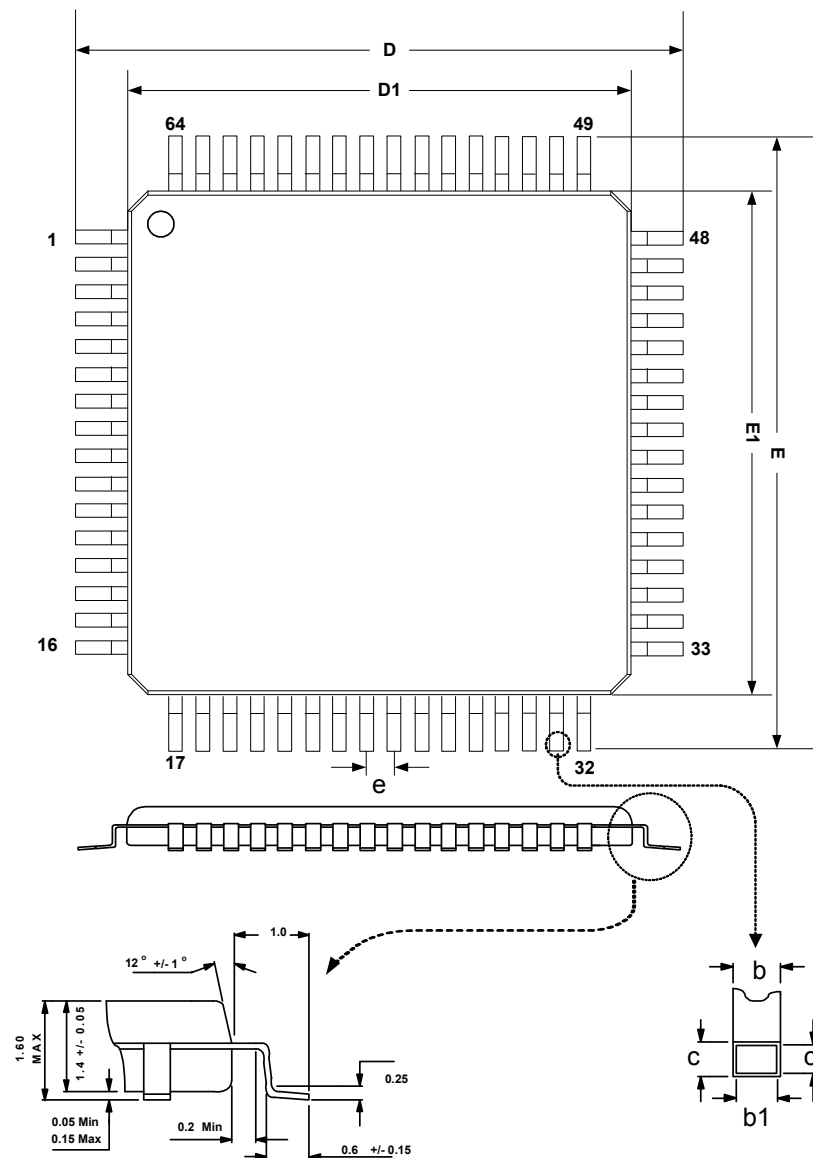
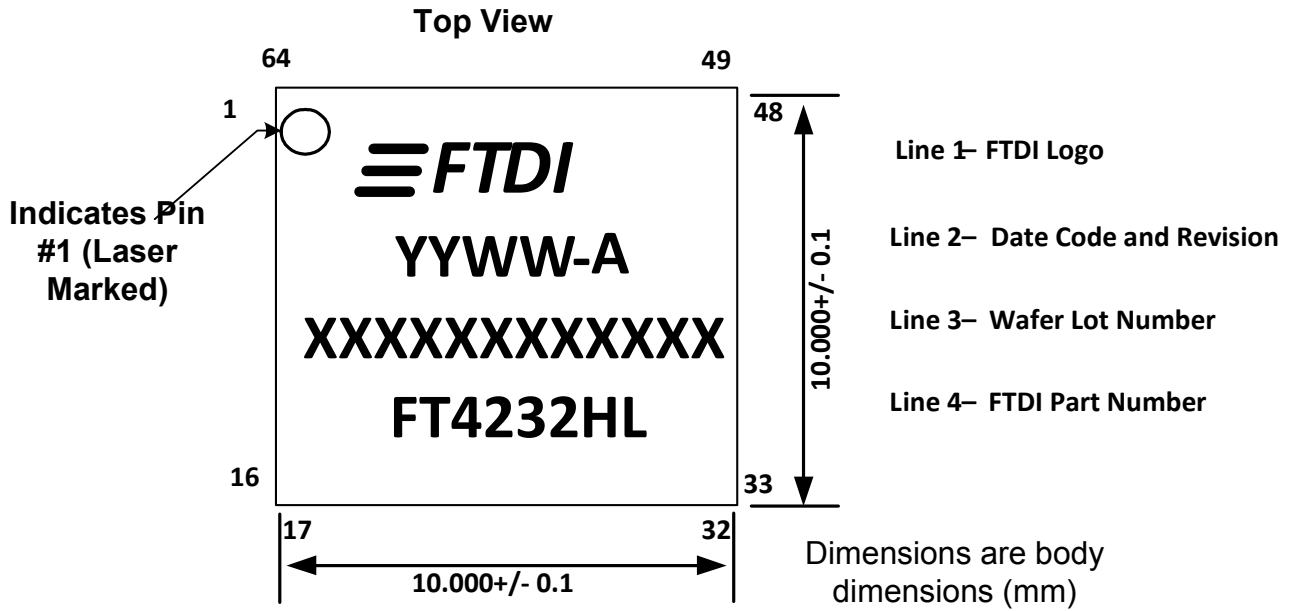

Figure 8.2 64 pin LQFP Package Details

SYMBOL	MIN	NOM	MAX
D	11.8	12	12.2
D1	9.9	10	10.1
E	11.8	12	12.2
E1	9.9	10	10.1
b	0.17	0.22	0.27
c	0.09		0.2
b1	0.17	0.2	0.23
c1	0.09		0.16
e		0.5 BSC	

Table 8.1 64 pin LQFP Package Details – dimensions (in mm)

8.3 Solder Reflow Profile

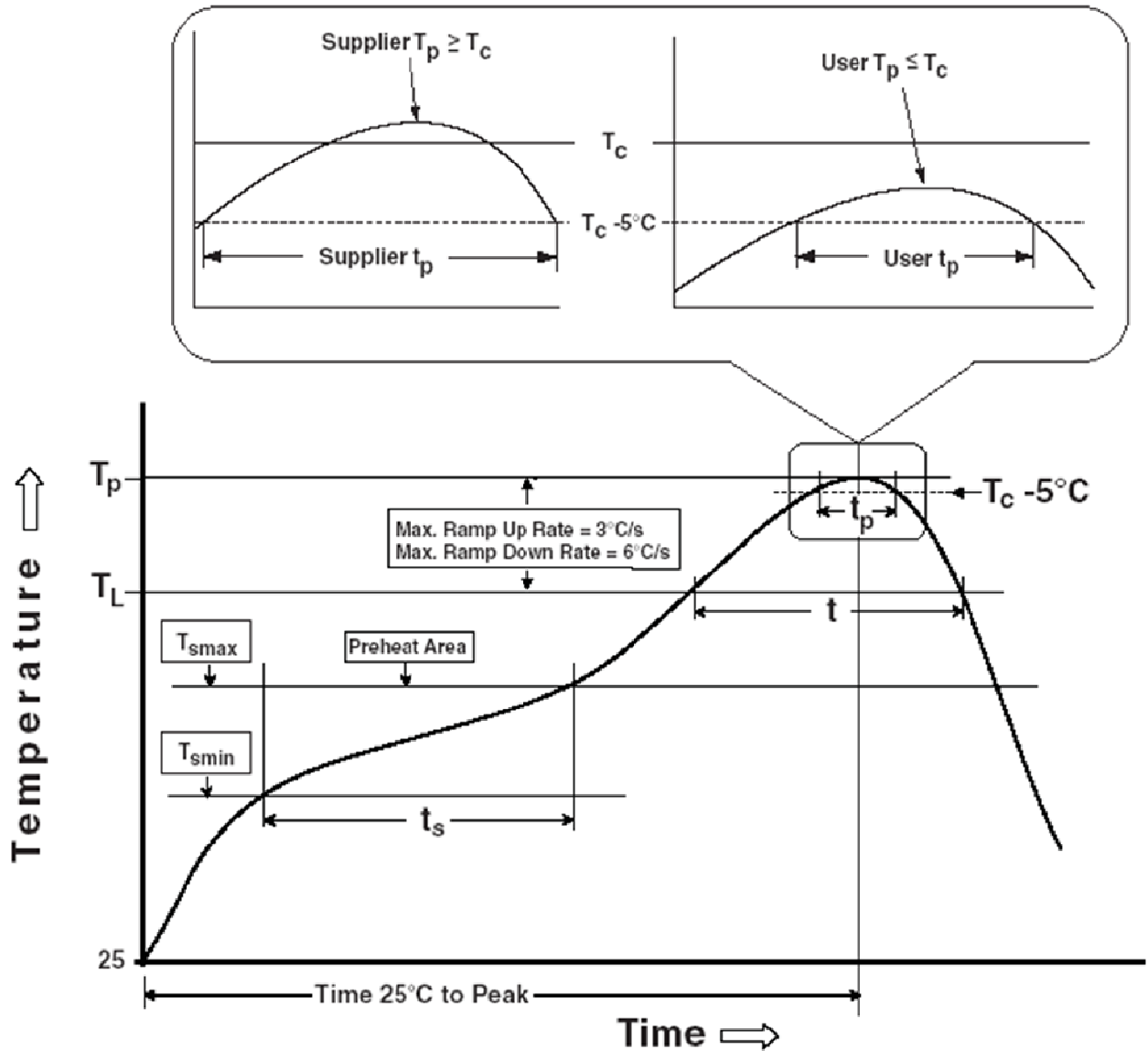

Figure 8.3 64 pin LQFP and QFN Reflow Solder Profile

Profile Feature	Pb Free Solder Process (green material)	SnPb Eutectic and Pb free (non green material) Solder Process
Average Ramp Up Rate (T_s to T_p)	3°C / second Max.	3°C / Second Max.
Preheat - Temperature Min (T_s Min.) - Temperature Max (T_s Max.) - Time (t_s Min to t_s Max)	150°C 200°C 60 to 120 seconds	100°C 150°C 60 to 120 seconds
Time Maintained Above Critical Temperature T_L : - Temperature (T_L) - Time (t_L)	217°C 60 to 150 seconds	183°C 60 to 150 seconds
Peak Temperature (T_p)	260°C	see Table 8.3
Time within 5°C of actual Peak Temperature (t_p)	30 to 40 seconds	20 to 40 seconds
Ramp Down Rate	6°C / second Max.	6°C / second Max.
Time for $T = 25^\circ\text{C}$ to Peak Temperature, T_p	8 minutes Max.	6 minutes Max.

Table 8.2 Reflow Profile Parameter Values

SnPb Eutectic and Pb free (non green material)		
Package Thickness	Volume mm ³ < 350	Volume mm ³ >=350
< 2.5 mm	235 +5/-0 deg C	220 +5/-0 deg C
≥ 2.5 mm	220 +5/-0 deg C	220 +5/-0 deg C
Pb Free (green material) = 260 +5/-0 deg C		

Table 8.3 Package Reflow Peak Temperature



9 Contact Information

Head Office – Glasgow, UK

Future Technology Devices International Limited
Unit 1, 2 Seaward Place,
Glasgow G41 1HH
United Kingdom
Tel: +44 (0) 141 429 2777
Fax: +44 (0) 141 429 2758

E-mail (Sales) vinculum.sales@ftdichip.com
E-mail (Support) vinculum.support@ftdichip.com
E-mail (General Enquiries) admin1@ftdichip.com
Web Site URL <http://www.ftdichip.com>
Web Shop URL <http://www.ftdichip.com>

Branch Office – Taipei, Taiwan

Future Technology Devices International Limited (Taiwan)
2F, No. 516, Sec. 1, NeiHu Road
Taipei 114
Taiwan, R.O.C.
Tel: +886 (0) 2 8797 1330
Fax: +886 (0) 2 8751 9737

E-mail (Sales) tw.sales1@ftdichip.com
E-mail (Support) tw.support1@ftdichip.com
E-mail (General Enquiries) tw.admin1@ftdichip.com
Web Site URL <http://www.ftdichip.com>

Branch Office – Hillsboro, Oregon, USA

Future Technology Devices International Limited (USA)
7235 NW Evergreen Parkway, Suite 600
Hillsboro, OR 97123-5803
USA
Tel: +1 (503) 547 0988
Fax: +1 (503) 547 0987

E-Mail (Sales) us.sales@ftdichip.com
E-Mail (Support) us.admin@ftdichip.com
Web Site URL <http://www.ftdichip.com>

Branch Office – Shanghai, China

Future Technology Devices International Limited (China)
Room 408, 317 Xianxia Road,
ChangNing District,
ShangHai, China

Tel: +86 (21) 62351596
Fax: +86(21) 62351595

E-Mail (Sales): cn.sales@ftdichip.com
E-Mail (Support): cn.support@ftdichip.com
E-Mail (General Enquiries): cn.admin1@ftdichip.com
Web Site URL: <http://www.ftdichip.com>

Distributor and Sales Representatives

Please visit the Sales Network page of the FTDI Web site for the contact details of our distributor(s) and sales representative(s) in your country.

Appendix A - List of Figures and Tables

List of Tables

Table 3.1 FT4232H Pin Configurations	9
Table 3.2 Power and Ground	10
Table 3.3 Common Function pins	11
Table 3.4 EEPROM Interface Group	11
Table 3.5 Channel A,B,C and Channel D Asynchronous Serial Interface Configured Pin Descriptions	12
Table 3.6 Channel A,B,C and Channel D Synchronous or Asynchronous Bit-Bang Configured Pin Descriptions	13
Table 3.7 Channel A and Channel B MPSSE Configured Pin Descriptions	14
Table 4.1 MPSSE Signal Timings	20
Table 4.2 Synchronous Bit-Bang Mode Timing Interface Example Timings.....	23
Table 5.1 Absolute Maximum Ratings	25
Table 5.2 Operating Voltage and Current.....	26
Table 5.3 I/O Pin Characteristics (except USB PHY pins)	27
Table 5.4 PHY Operating Voltage and Current.....	28
Table 5.5 PHY I/O Pin Characteristics	28
Table 6.1 OSCI Input characteristics	33
Table 8.1 64 pin LQFP Package Details – dimensions (in mm).....	39
Table 8.2 Reflow Profile Parameter Values	41
Table 8.3 Package Reflow Peak Temperature.....	41

List of Figures

Figure 2.1 FT4232H Block Diagram	4
Figure 3.1 FT4232H Schematic Symbol	7
Figure 4.1 RS232 Configuration	17
Figure 4.2 Dual RS422 Configuration.....	18
Figure 4.3 Dual RS485 Configuration.....	19
Figure 4.4 MPSSE Signal Waveforms	20
Figure 4.5 Adaptive Clocking Interconnect	21
Figure 4.6: Adaptive Clocking waveform.	21
Figure 4.7 Synchronous Bit-Bang Mode Timing Interface Example	23
Figure 6.1 Bus Powered Configuration Example 1.....	29
Figure 6.2 Bus Powered Configuration Example 2.....	30
Figure 6.3 Self Powered Configuration Example 1	31
Figure 6.4 Self Powered Configuration Example 2	32
Figure 6.5 Recommended FT4232H Crystal Oscillator Configuration.	33
Figure 6.6 Using 74HCT595 to Indicate Tx and Rx Data	34
Figure 8.1 64 pin QFN Package Details	37
Figure 8.2 64 pin LQFP Package Details	38
Figure 8.3 64 pin LQFP and QFN Reflow Solder Profile	40

Appendix B - Revision History

Revision History

Version draft	Initial Datasheet Created	October 2008
Version Preliminary	Preliminary Datasheet Released	23 rd October 2008
Version 1.00	Datasheet Released	4 th November 2008
Version 1.10	QFN package update	November 2008
Version 2.00	Various Updates	January 2009
Version 2.01	Changed description of bit-bang mode	February 2009
Version 2.02	Corrected QFN tray numbers from 160 to 260 per tray	March 2009
Version 2.03	Corrected signal names in Fig 2.1 Added reference to AN_109, AN_110, AN_111 and AN_113. Corrected default of RI#/ TXDEN in table 3.1	19 th May 2009
Version 2.04	Added paragraph on latency timer to section 4.1	3 rd June 2009
Version 2.05	Corrected Figures 6.2, 6.3 and 6.4 – missing regulators and better way of holding self powered designs in reset if not connected to USB. Corrected Max DC inputs on “DC Input Voltage – “All Other Inputs” pins from VCORE+0.5V to VCCIO+0.5V	17 th June 2009
Version 2.06	Added explanation of MPSSE Adaptive clocking (4.4.1). Corrected 12MHz crystal specification	21 st Sept 2009