

# Zero Differential Pressure Type Pilot Operated

2 Port Solenoid Valve



For Air, Water, Oil



Reduced  
power consumption  
(DC spec.)

VXZ22: 8 W → **7 w**

VXZ23: 11.5 W → **10.5 w**

**New**  
**VXZ** Series VXZ22/23

# Solenoid valves for various fluids used in a wide variety of

**Improved corrosion resistance**  
Special magnetic material adopted

**Enclosure: IP65**

**Low-noise construction**  
Special construction enables to reduce the metal noise. (DC spec.)

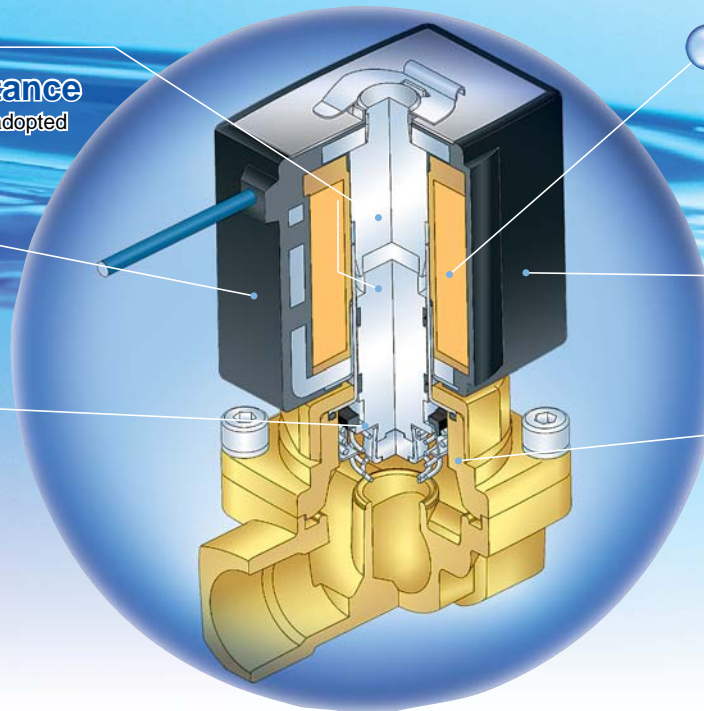

**Reduced power consumption (DC spec.)**

VXZ22: 8 W → **7 W**

VXZ23: 11.5 W → **10.5 W**

**Flame resistance**  
**UL94V-0 conformed**  
Flame resistant mold coil material

**Improved maintenance performance**  
Maintenance is performed easily due to the threaded assembly.

## Pilot Operated 2 Port Solenoid Valve

For Air, Water, Oil

**New Series VXZ22/23**

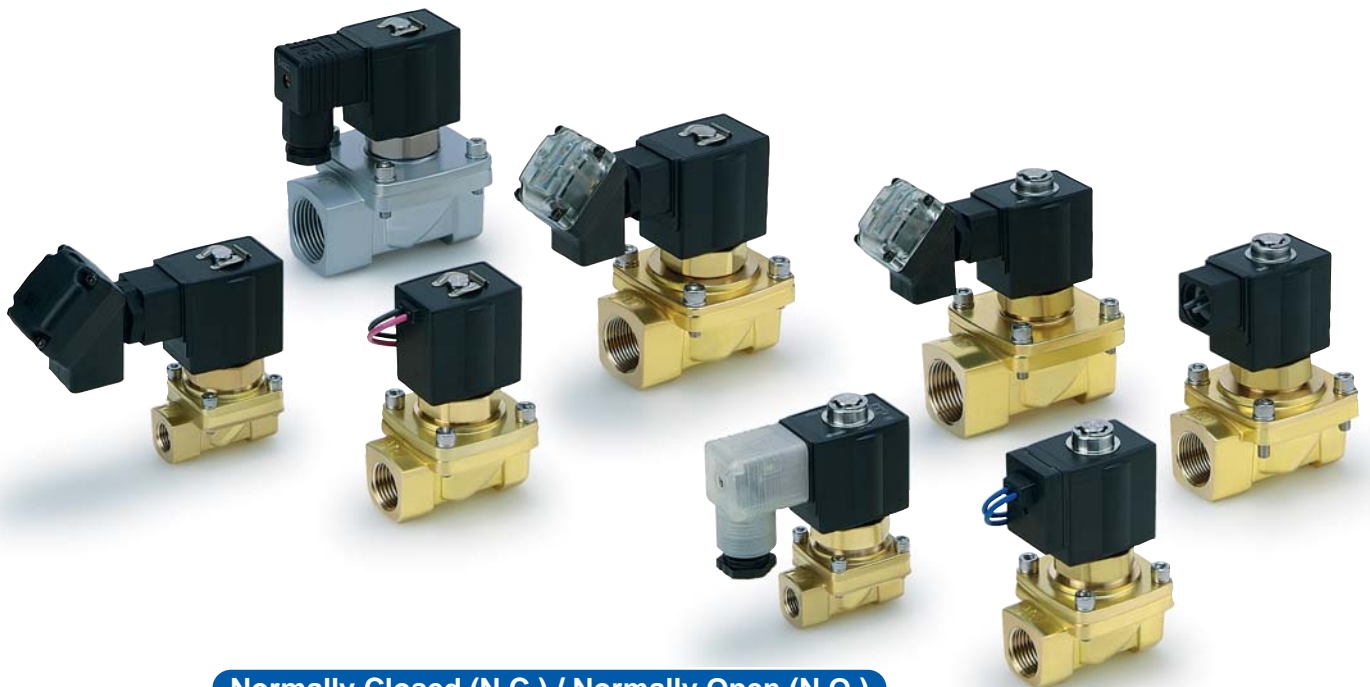

### Normally Closed (N.C.) / Normally Open (N.O.)

Solenoid valve (Port size)			Orifice size				Material	
Model	VXZ22	VXZ23	3 (10 mmø)	4 (15 mmø)	5 (20 mmø)	6 (25 mmø)	Body	Seal
Port no. (Port size)	<b>02</b> (1/4)	—	●	—	—	—	Brass Stainless steel	NBR
	<b>03</b> (3/8)	—	●	—	—	—		
	<b>04</b> (1/2)	—	—	●	—	—		
	—	<b>06</b> (3/4)	—	—	●	—		
	—	<b>10</b> (1)	—	—	—	●		

# applications — **New VX Series variations**

## Direct Operated 2 Port

### New VX21/22/23

For Air, Vacuum, Water, Steam, Oil



Valve type	Port size	Orifice size mmØ
N.C./N.O.	1/8 to 1/2	2 to 10

## Pilot Operated 2 Port

### New VXD21/22/23

For Water, Oil, Air



Valve type	Port size	Orifice size mmØ
N.C./N.O.	1/4 to 1 32 A to 50 A	10 to 50

## Direct Operated 3 Port

### New VX31/32/33

For Air, Vacuum, Water, Steam, Oil



Valve type	Port size	Orifice size mmØ
N.C./N.O. COM.	1/8 to 3/8	1.5 to 4

## Air Operated 2/3 Port

### VXA21/22, VXA31/32

For Air, Vacuum, Water, Oil



Model	Valve type	Port size	Orifice size mmØ
VXA21/22	N.C./N.O.	1/8 to 1/2	3 to 10
VXA31/32	COM.	1/8 to 3/8	1.5 to 4

## Pilot Operated 2 Port for High Pressure

### VXH22

For Air, Water, Oil

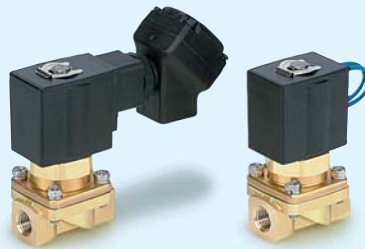

Valve type	Port size	Orifice size mmØ
N.C.	1/4 to 1/2	10

The **new VX series**, with its improved construction, replaces our previous VX range.



# Zero Differential Pressure Type Pilot Operated 2 Port Solenoid Valve

## Series VXZ22/23

For Air, Water, Oil

Specifications



### Valve

Normally closed (N.C.)  
Normally open (N.O.)

### Solenoid Coil

Coil: Class B, Class H

### Rated Voltage

100 VAC, 200 VAC, 110 VAC,  
220 VAC, 240 VAC, 230 VAC,  
48 VAC, 24 VDC, 12 VDC

### Material

Body — Brass, Stainless steel  
Seal — NBR, FKM, EPDM



### Electrical Entry

- Grommet
- Conduit
- DIN terminal
- Conduit terminal

Model	VXZ223 <sup>2</sup> <sub>0</sub>	VXZ224 <sup>2</sup> <sub>0</sub>	VXZ235 <sup>2</sup> <sub>0</sub>	VXZ236 <sup>2</sup> <sub>0</sub>
Orifice size	10 mmø	●	—	—
	15 mmø	—	●	—
	20 mmø	—	—	●
	25 mmø	—	—	—
Port size (Flange)	1/4 (8A) 3/8 (10A)	1/2 (15A)	3/4 (20A)	1 (25A)

For Air

For Water

For Oil

Construction

Dimensions

# Common Specifications

## Standard Specifications

Valve specifications	Valve construction		Zero differential pressure type pilot operated 2 port diaphragm type
	Withstand pressure (MPa)		5.0
	Body material		Brass (C37), Stainless steel
	Seal material		NBR, FKM, EPDM
	Enclosure		Dust - tight, Low jetproof (equivalent to IP65)*
	Environment		Location without corrosive or explosive gases
	Vibration resistance/Impact resistance (m/s <sup>2</sup> )		30/150 or less
Coil specifications	Rated voltage	AC (Class B coil, Built-in full-wave rectifier type)	100 VAC, 200 VAC, 110 VAC, 220 VAC, 230 VAC, 240 VAC, 48 VAC
		AC (Class H coil)	
		DC (Class B coil only)	24 VDC, 12 VDC
	Allowable voltage fluctuation		±10% of rated voltage
	Allowable leakage voltage	AC (Class B coil, Built-in full-wave rectifier type)	10% or less of rated voltage
		AC (Class H coil)	20% or less of rated voltage
		DC (Class B coil only)	2% or less of rated voltage
Coil insulation type		Class B, Class H	

\* Electrical entry: Grommet with surge voltage suppressor (GS) has a rating of IP40.

## Solenoid Coil Specifications

### DC Specification (Class B coil only)

Model	Power consumption (W)	Temperature rise (C°) <sup>Note</sup>
VXZ22	7	45
VXZ23	10.5	60

Note) The value at ambient temperature of 20°C and when the rated voltage is applied.

### AC Specification (Class B coil, Built-in full-wave rectifier type)

Model	Apparent power (VA) <sup>Note 2)</sup>	Temperature rise (C°) <sup>Note 1)</sup>
VXZ22	9.5	60
VXZ23	12	65

Note 1) The value at ambient temperature of 20°C and when the rated voltage is applied.

Note 2) There is no difference in the frequency and the inrush and energised apparent power, since a rectifying circuit is used in the AC spec. (Class B coil, Built-in full-wave rectifier type).

### AC Specification (Class H coil)

Model	Frequency (Hz)	Apparent power (VA)		Temperature rise (C°) <sup>Note</sup>
		Inrush	Energised	
VXZ22	50	65	33	100
	60	55	27	95
VXZ23	50	94	50	120
	60	79	41	115

Note) The value at ambient temperature of 20°C and when the rated voltage is applied.

# Applicable Fluid Check List

## All Options

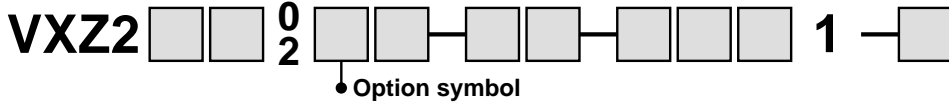

Fluid and application	Option symbol	Seal material	Body/ Shading coil material <small>Note 5)</small>	Guide ring and push rod (N.O. only) material	Coil insulation type <small>Note 3)</small>	Note
Air	-	NBR	Brass (C37)/-	PPS	B	
	G		Stainless steel/-			
Water	-	NBR	Brass (C37)/-		B	
	G		Stainless steel/-			
Heated water	E	EPDM	Brass (C37)/Cu		H	
	P		Stainless steel/Ag			
Oil <small>Note 2)</small>	A	FKM	Brass (C37)/-		B	
	H		Stainless steel/-			
	D		Brass (C37)/Cu			
	N		Stainless steel/Ag			
High corrosive spec., Oil-free	L <small>Note 1)</small>	FKM	Stainless steel/-		B	
Copper-free, Fluoro-free <small>Note 4)</small>	J	EPDM	Stainless steel/-		B	
	P		Stainless steel/Ag	H		
Other combinations	B	EPDM	Brass (C37)/-	B		

Note 1) "L" option is the oil-free treatment.

Note 2) The kinematic viscosity of the fluid must not exceed 50 mm<sup>2</sup>/s.

The special construction of the armature adopted in the built-in full-wave rectifier type gives an improvement in OFF response by providing clearance on the absorbed surface when it is switched ON.

Select the DC spec. or AC spec. (Built-in full-wave rectifier type) when the kinematic viscosity is higher than water or when the OFF response is prioritised.

Note 3) Coil insulation type Class H: AC spec. only

Note 4) The nuts (non-wetted parts) are nickel plated brass (C37) material.

Note 5) There is no shading coil attached to the DC spec. or AC spec (Built-in full-wave rectifier type).

\* Please contact SMC when fluids other than above are used.

Specifications

For Air

For Water

For Oil

Construction

Dimensions

# Series VXZ22/23

## For Air

(Inert gas)

### Model/Valve Specifications

**N.C.**

Passage symbol

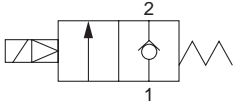

**N.O.**

Passage symbol

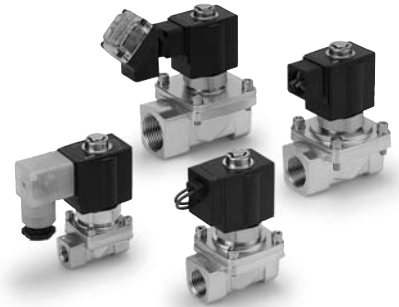
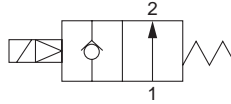

#### Normally Closed (N.C.)

Port size (Nominal size)	Orifice size (mm)	Model	Min. operating pressure differential (MPa)	Max. operating pressure differential (MPa)		Flow characteristics			Max. system pressure (MPa)	Weight (g)
				AC	DC	C	b	Cv		
1/4 (8A)	10	VXZ2230-02	0	1.0	0.7	8.5	0.44	2.4	1.5	550
3/8 (10A)		VXZ2230-03				11.0	0.42	2.8		
1/2 (15A)	VXZ2240-04	23.0				0.34	6.0			
3/4 (20A)	VXZ2350-06	38.0				0.20	9.5			

Port size (Nominal size)	Orifice size (mmø)	Model	Min. operating pressure differential (MPa)	Max. operating pressure differential (MPa)		Flow characteristics	Max. system pressure (MPa)	Weight (g)
				AC	DC	Effective area (mm <sup>2</sup> )		
1 (25A)	25	VXZ2360-10	0	1.0	0.7	215	1.5	1480

Note) Weight of grommet type. Add 10 g for conduit type, 30 g for DIN terminal type, 60 g for conduit terminal type respectively.

• Refer to "Glossary of Terms" on page 20 for details on the max. operating pressure differential and the max. system pressure.

#### Normally Open (N.O.)

Port size (Nominal size)	Orifice size (mmø)	Model	Min. operating pressure differential (MPa)	Max. operating pressure differential (MPa)		Flow characteristics			Max. system pressure (MPa)	Weight (g)
				AC	DC	C	b	Cv		
1/4 (8A)	10	VXZ2232-02	0	0.7	0.6	8.5	0.44	2.4	1.5	600
3/8 (10A)		VXZ2232-03				11.0	0.42	2.8		
1/2 (15A)	VXZ2242-04	23.0				0.34	6.0			
3/4 (20A)	VXZ2352-06	38.0				0.20	9.5			

Port size (Nominal size)	Orifice size (mmø)	Model	Min. operating pressure differential (MPa)	Max. operating pressure differential (MPa)		Flow characteristics	Max. system pressure (MPa)	Weight (g)
				AC	DC	Effective area (mm <sup>2</sup> )		
1 (25A)	25	VXZ2362-10	0	0.7	0.6	215	1.5	1550

Note) Weight of grommet type. Add 10 g for conduit type, 30 g for DIN terminal type, 60 g for conduit terminal type respectively.

• Refer to "Glossary of Terms" on page 20 for details on the max. operating pressure differential and the max. system pressure.

### Ambient and Fluid Temperature

Power source	Fluid temperature (°C)	Ambient temperature (°C)
	Solenoid valve option symbol	
	-	<b>G</b>
AC/Class B coil	-10 to 60 <small>Note)</small>	-10 to 60
DC	-10 to 60 <small>Note)</small>	-10 to 60

Note) Dew point temperature: -10°C or less.

### Valve Leakage Rate

#### Internal Leakage

Seal material	Leakage rate (Air)
NBR	1 cm <sup>3</sup> /min or less

#### External Leakage

Seal material	Leakage rate (Air)
NBR	1 cm <sup>3</sup> /min or less

### How to Order

**DC**

**AC/Class B coil (Built-in full-wave rectifier type)**

VXZ 22 3 0     02   5 G 1  

VXZ 22 3 0     02   1 G R1

Specifications

For Air

For Water

For Oil

Construction

Dimensions

**Model** • Refer to the table (1) shown below for availability.

**Orifice size** • Refer to the table (1) shown below for availability.

**Valve/Body configuration** •

0	N.C. / Single unit
2	N.O. / Single unit

**Solenoid valve option** • Refer to the table (2) shown below for availability.

**Suffix** •

-	—
Z	Oil-free spec.

**Port size** • Refer to the table (1) shown below for availability.

**Thread type** •

-	Rc
T	NPTF
F	G
N	NPT

**Rated voltage** •

1	100 VAC 50/60 Hz	6	12 VDC
2	200 VAC 50/60 Hz	7	240 VAC 50/60 Hz
3	110 VAC 50/60 Hz	8	48 VAC 50/60 Hz
4	220 VAC 50/60 Hz	J	230 VAC 50/60 Hz
5	24 VDC		

\* Refer to the table (3) shown below for availability.

Refer to page 12 for ordering coil only.

**Bracket**

-	None
B	With bracket

\* Bracket is not removable.

**Built-in full-wave rectifier type**

**Electrical entry**

<p><b>G</b> - Grommet <b>GS</b> - With grommet surge voltage suppressor</p>	<p><b>C</b> - Conduit</p>
<p><b>T</b> - With conduit terminal <b>TS</b> - With conduit terminal and surge voltage suppressor <b>TL</b> - With conduit terminal and light <b>TZ</b> - With conduit terminal, surge voltage suppressor and light</p>	<p><b>D</b> - DIN terminal <b>DS</b> - DIN terminal with surge voltage suppressor <b>DL</b> - DIN terminal with light <b>DZ</b> - DIN terminal with surge voltage suppressor and light <b>DO</b> - For DIN terminal (without connector, gasket is included.)</p> <p>Connector</p>

\* Refer to the table (3) for the available combinations between each electrical option (S, L, Z) and rated voltage.  
\* A surge voltage suppressor is integrated into the AC/Class B coil, as standard.

**Table (1) Model – Orifice Size – Port Size**  
Normally Closed (N.C.) / Normally Open (N.O.)

Model	Solenoid valve (Port size)		Orifice symbol (Diameter)				Material	
	VXZ22	VXZ23	3 (10 mmø)	4 (15 mmø)	5 (20 mmø)	6 (25 mmø)	Body	Seal
Port no. (Port size)	02 (1/4)	—	●	—	—	—	Brass (C37), Stainless steel	NBR
	03 (3/8)	—	●	—	—	—		
	04 (1/2)	—	—	●	—	—		
	—	06 (3/4)	—	—	●	—		
	—	10 (1)	—	—	—	●		

**Table (2) Solenoid Valve Option**

Option symbol	Seal material	Body material	Coil insulation type	Note
-	NBR	Brass (C37)	B	—
G		Stainless steel		

**Table (3) Rated Voltage – Electrical Option**

AC/DC	Rated voltage		Class B		
	Voltage symbol	Voltage	S	L	Z
AC	1	100 V	—	●	—
	2	200 V	—	●	—
	3	110 V	—	●	—
	4	220 V	—	●	—
	7	240 V	—	—	—
	8	48 V	—	—	—
DC	J	230 V	—	—	—
	5	24 V	●	●	●
	6	12 V	●	—	—

\* Option "S", "Z" are not available as a surge voltage suppressor is integrated into the AC/Class B coil, as standard.

## For Water

### Model/Valve Specifications

**N.C.**

Passage symbol

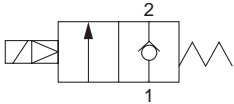

**N.O.**

Passage symbol

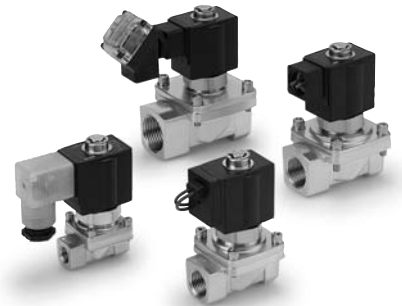
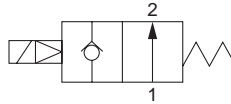

#### Normally Closed (N.C.)

Port size (Nominal size)	Orifice size (mmø)	Model	Min. operating pressure differential (MPa)	Max. operating pressure differential (MPa)		Flow characteristics		Max. system pressure (MPa)	Weight (g)
				AC	DC	Av x 10 <sup>-6</sup> m <sup>2</sup>	Cv converted		
1/4 (8A)	10	VXZ2230-02	0	1.0	0.7	46	1.9	1.5	550
3/8 (10A)		VXZ2230-03				58	2.4		
1/2 (15A)	VXZ2240-04	130				5.3			
3/4 (20A)	VXZ2350-06	220				9.2			
1 (25A)	VXZ2360-10	290				12.0			

Note) Weight of grommet type. Add 10 g for conduit type, 30 g for DIN terminal type, 60 g for conduit terminal type respectively.

• Refer to "Glossary of Terms" on page 20 for details on the max. operating pressure differential and the max. system pressure.

#### Normally Open (N.O.)

Port size (Nominal size)	Orifice size (mmø)	Model	Min. operating pressure differential (MPa)	Max. operating pressure differential (MPa)		Flow characteristics		Max. system pressure (MPa)	Weight (g)
				AC	DC	Av x 10 <sup>-6</sup> m <sup>2</sup>	Cv converted		
1/4 (8A)	10	VXZ2232-02	0	0.7	0.6	46	1.9	1.5	600
3/8 (10A)		VXZ2232-03				58	2.4		
1/2 (15A)	VXZ2242-04	130				5.3			
3/4 (20A)	VXZ2352-06	220				9.2			
1 (25A)	VXZ2362-10	290				12.0			

Note) Weight of grommet type. Add 10 g for conduit type, 30 g for DIN terminal type, 60 g for conduit terminal type respectively.

• Refer to "Glossary of Terms" on page 20 for details on the max. operating pressure differential and the max. system pressure.

### Ambient and Fluid Temperature

Power source	Fluid temperature (°C)		Ambient temperature (°C)
	Solenoid valve option symbol		
	-, G, L	E, P	
AC/Class B coil	1 to 60	—	-10 to 60
AC/Class H coil	—	1 to 99	-10 to 60
DC	1 to 60	—	-10 to 60



Note) With no freezing

### Valve Leakage Rate

#### Internal Leakage

Seal material	Leakage rate (Water)
NBR, FKM, EPDM	0.1 cm <sup>3</sup> /min or less

#### External Leakage

Seal material	Leakage rate (Water)
NBR, FKM, EPDM	0.1 cm <sup>3</sup> /min or less

## How to Order

DC

**VXZ 22 3 0 [ ] [ ] - 02 [ ] - 5 G 1 - [ ]**

AC/Class H coil

**VXZ 22 3 0 [ ] [ ] - 02 [ ] - 1 G 1 - [ ]**

AC/Class B coil (Built-in full-wave rectifier type)

**VXZ 22 3 0 [ ] [ ] - 02 [ ] - 1 GR1 - [ ]**

**Model** • Refer to the table (1) shown below for availability.

**Orifice size** • Refer to the table (1) shown below for availability.

**Valve/Body configuration** •

0	N.C. / Single unit
2	N.O. / Single unit

**Solenoid valve option** • Refer to the table (2) shown below for availability.

**Port size** • Refer to the table (1) shown below for availability.

**Thread type** •

-	Rc
T	NPTF
F	G
N	NPT

**Rated voltage** •

1	100 VAC 50/60 Hz	6	12 VDC
2	200 VAC 50/60 Hz	7	240 VAC 50/60 Hz
3	110 VAC 50/60 Hz	8	48 VAC 50/60 Hz
4	220 VAC 50/60 Hz	J	230 VAC 50/60 Hz
5	24 VDC		

\* Refer to the table (3) shown below for availability.

**Suffix** •

-	-
Z	Oil-free spec.

Select "-" because the solenoid valve option "L" is the oil-free treatment.

**Bracket**

-	None
B	With bracket

\* Bracket is not removable.

**Electrical entry** •

**G - Grommet**  
**GS - With grommet surge voltage suppressor**

**C - Conduit**

**T - With conduit terminal**  
**TS - With conduit terminal and surge voltage suppressor**  
**TL - With conduit terminal and light**  
**TZ - With conduit terminal, surge voltage suppressor and light**

**D - DIN terminal**  
**DS - DIN terminal with surge voltage suppressor**  
**DL - DIN terminal with light**  
**DZ - DIN terminal with surge voltage suppressor and light**  
**DO - For DIN terminal (without connector, gasket is included.)**

Connector

\* DIN type is available with class B only.

**Table (1) Model – Orifice Size – Port Size**

**Normally Closed (N.C.) / Normally Open (N.O.)**

Model	Solenoid valve (Port size)		Orifice symbol (Diameter)				Material	
	VXZ22	VXZ23	3 (10 mmø)	4 (15 mmø)	5 (20 mmø)	6 (25 mmø)	Body	Seal
Port no. (Port size)	02 (1/4)	—	●	—	—	—	Brass (C37), Stainless steel	NBR FKM EPDM
	03 (3/8)	—	●	—	—	—		
	04 (1/2)	—	—	●	—	—		
	—	06 (3/4)	—	—	●	—		
	—	10 (1)	—	—	—	●		

**Table (2) Solenoid Valve Option**

Option symbol	Seal material	Body/Shading coil material*	Coil insulation type	Note
-	NBR	Brass (C37)/—	B	—
G		Stainless steel/—		
E	EPDM	Brass (C37)/Cu	H	Heated water (AC only)
P		Stainless steel/Ag		
L	FKM	Stainless steel/—	B	High corrosive, Oil-free

\* There is no shading coil attached to the AC/Class B coil and DC spec.

**Table (3) Rated Voltage – Electrical Option**

AC/DC	Rated voltage		Class B			Class H		
			S	L	Z	S	L	Z
	Voltage symbol	Voltage	With surge voltage suppressor	With light	With light and surge voltage suppressor	With surge voltage suppressor	With light	With light and surge voltage suppressor
AC	1	100 V	—	●	—	●	●	●
	2	200 V	—	●	—	●	●	●
	3	110 V	—	●	—	●	●	●
	4	220 V	—	●	—	●	●	●
	7	240 V	—	—	—	●	—	—
	8	48 V	—	—	—	●	—	—
DC	J	230 V	—	—	—	●	—	—
	5	24 V	●	●	●	DC spec. is not available.		
	6	12 V	●	—	—	DC spec. is not available.		

\* Option "S", "Z" are not available as a surge voltage suppressor is integrated into the AC/Class B coil, as standard.

\* Class B and H coils cannot be interchanged.

\* AC/Class B coil (Built-in full wave rectifier type) can be interchanged with DC.

7

Specifications

For Air

For Water

For Oil

Construction

Dimensions

# Series VXZ22/23

⚠ When the fluid is oil.

The kinematic viscosity of the fluid must not exceed 50 mm<sup>2</sup>/s.

The special construction of the armature adopted in the built-in full-wave rectifier type gives an improvement in OFF response by providing clearance on the absorbed surface when it is switched ON.

Select the DC spec. or AC spec. (Built-in full-wave rectifier type) when the kinematic viscosity is higher than water or when the OFF response is prioritised.

## For Oil

### Model/Valve Specifications

**N.C.**

Passage symbol

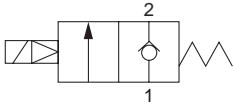

**N.O.**

Passage symbol

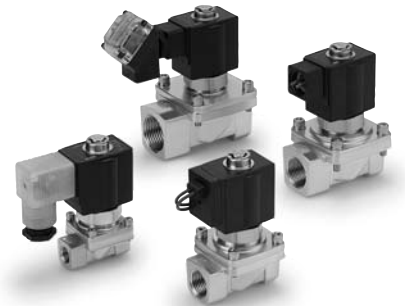
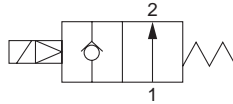

#### Normally Closed (N.C.)

Port size (Nominal size)	Orifice size (mmø)	Model	Min. operating pressure differential (MPa)	Max. operating pressure differential (MPa)		Flow characteristics		Max. system pressure (MPa)	Weight (g)
				AC	DC	Av x 10 <sup>-6</sup> m <sup>2</sup>	Cv converted		
1/4 (8A)	10	VXZ2230-02	0	0.7		46	1.9	1.5	550
3/8 (10A)		VXZ2230-03				58	2.4		
1/2 (15A)	15	VXZ2240-04				130	5.3		
3/4 (20A)	20	VXZ2350-06				220	9.2		
1 (25A)	25	VXZ2360-10				290	12.0		

Note) Weight of grommet type. Add 10 g for conduit type, 30 g for DIN terminal type, 60 g for conduit terminal type respectively.

• Refer to "Glossary of Terms" on page 20 for details on the max. operating pressure differential and the max. system pressure.

#### Normally Open (N.O.)

Port size (Nominal size)	Orifice size (mmø)	Model	Min. operating pressure differential (MPa)	Max. operating pressure differential (MPa)		Flow characteristics		Max. system pressure (MPa)	Weight (g)
				AC	DC	Av x 10 <sup>-6</sup> m <sup>2</sup>	Cv converted		
1/4 (8A)	10	VXZ2232-02	0	0.7	0.6	46	1.9	1.5	600
3/8 (10A)		VXZ2232-03				58	2.4		
1/2 (15A)	15	VXZ2242-04				130	5.3		
3/4 (20A)	20	VXZ2352-06				220	9.2		
1 (25A)	25	VXZ2362-10				290	12.0		

Note) Weight of grommet type. Add 10 g for conduit type, 30 g for DIN terminal type, 60 g for conduit terminal type respectively.

• Refer to "Glossary of Terms" on page 20 for details on the max. operating pressure differential and the max. system pressure.

### Ambient and Fluid Temperature

Power source	Fluid temperature (°C)		Ambient temperature (°C)
	Solenoid valve option symbol		
	A, H	D, N	
AC/Class B coil	-5 to 60	—	-10 to 60
AC/Class H coil	—	-5 to 100	-10 to 60
DC	-5 to 60	—	-10 to 60

Note) Kinematic viscosity: 50 mm<sup>2</sup>/s or less

### Valve Leakage Rate

#### Internal Leakage

Seal material	Leakage rate (Oil)
FKM	0.1 cm <sup>3</sup> /min or less

#### External Leakage

Seal material	Leakage rate (Oil)
FKM	0.1 cm <sup>3</sup> /min or less

## How to Order

**DC**

**AC/Class H coil**

**AC/Class B coil (Built-in full-wave rectifier type)**

**VXZ 22 3 0 [ ] [ ] - 02 [ ] - 5 G 1 - [ ]**

**VXZ 22 3 0 [ ] [ ] - 02 [ ] - 1 G 1 - [ ]**

**VXZ 22 3 0 [ ] [ ] - 02 [ ] - 1 G R1 - [ ]**

Specifications

For Air

For Water

For Oil

Construction

Dimensions

**Model** • Refer to the table (1) shown below for availability.

**Orifice size** • Refer to the table (1) shown below for availability.

**Valve/Body configuration** •

0	N.C. / Single unit
2	N.O. / Single unit

**Suffix** •

-	—
Z	Oil-free spec.

**Solenoid valve option** • Refer to the table (2) shown below for availability.

-	Rc
T	NPTF
F	G
N	NPT

**Port size** • Refer to the table (1) shown below for availability.

**Thread type** •

-	Rc
T	NPTF
F	G
N	NPT

**Rated voltage** •

1	100 VAC 50/60 Hz	6	12 VDC
2	200 VAC 50/60 Hz	7	240 VAC 50/60 Hz
3	110 VAC 50/60 Hz	8	48 VAC 50/60 Hz
4	220 VAC 50/60 Hz	J	230 VAC 50/60 Hz
5	24 VDC		

\* Refer to the table (3) shown below for availability.

Refer to page 12 for ordering coil only.

**Electrical entry** •

<p><b>G - Grommet</b> GS - With grommet surge voltage suppressor</p>	<p><b>C-Conduit</b></p>
<p><b>T -With conduit terminal</b> TS -With conduit terminal and surge voltage suppressor</p>	<p><b>D - DIN terminal</b> DS - DIN terminal with surge voltage suppressor</p>
<p><b>TL -With conduit terminal and light</b> TZ -With conduit terminal, surge voltage suppressor and light</p>	<p><b>DL - DIN terminal with light</b> DZ - DIN terminal with surge voltage suppressor and light</p>
<p><b>DO -For DIN terminal (without connector, gasket is included.)</b> * DIN type is available with class B only.</p>	

**Table (1) Model – Orifice Size – Port Size**  
Normally Closed (N.C.) / Normally Open (N.O.)

		Solenoid valve (Port size)		Orifice symbol (Diameter)				Material	
Model		VXZ22	VXZ23	3 (10 mmø)	4 (15 mmø)	5 (20 mmø)	6 (25 mmø)	Body	Seal
Port no. (Port size)	02 (1/4)	—	—	●	—	—	—	Brass (C37), Stainless steel	FKM
	03 (3/8)	—	—	●	—	—	—		
	04 (1/2)	—	—	—	●	—	—		
	—	06 (3/4)	—	—	—	●	—		
	—	10 (1)	—	—	—	—	●		

**Table (2) Solenoid Valve Option**

Option symbol	Seal material	Body/Shading coil material*	Coil insulation type
A	FKM	Brass (C37)/—	B
H		Stainless steel/—	
D		Brass (C37)/Cu	H
N		Stainless steel/Ag	

\* There is no shading coil attached to the AC/Class B coil and DC spec.

**Table (3) Rated Voltage – Electrical Option**

Rated voltage		Class B			Class H			
		S	L	Z	S	L	Z	
AC/DC	Voltage symbol	Voltage	With surge voltage suppressor	With light	With light and surge voltage suppressor	With surge voltage suppressor	With light	With light and surge voltage suppressor
AC	1	100 V	—	●	—	●	●	●
	2	200 V	—	●	—	●	●	●
	3	110 V	—	●	—	●	●	●
	4	220 V	—	●	—	●	●	●
	7	240 V	—	—	—	●	—	—
	8	48 V	—	—	—	●	—	—
DC	J	230 V	—	—	—	●	—	—
	5	24 V	●	●	●	DC spec. is not available.		
	6	12 V	●	—	—	DC spec. is not available.		

\* Option "S", "Z" are not available as a surge voltage suppressor is integrated into the AC/Class B coil, as standard.

\* Class B and H coils cannot be interchanged.

\* AC/Class B coil (Built-in full wave rectifier type) can be interchanged with DC.

# Series VXZ22/23

For Air, Water, Oil

## Construction

### Normally closed (N.C.)

Body material: Brass, Stainless steel

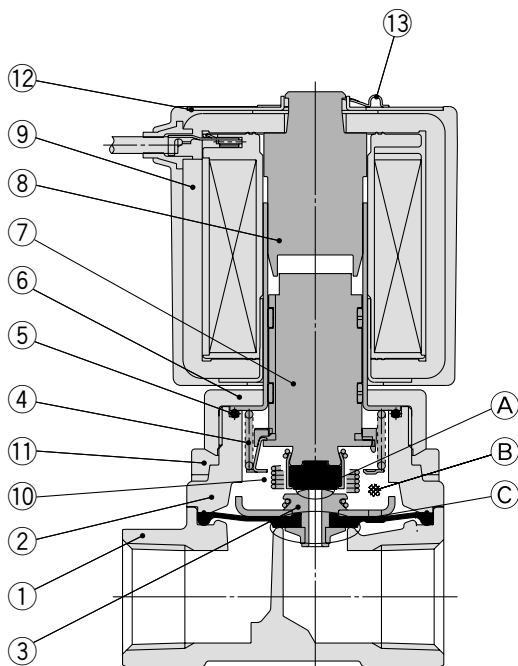

### Working principles

<Valve opened – when there is pressure>

When the coil ⑨ is energised, the armature assembly ⑦ is attracted into the core of the tube assembly ⑧ and the pilot valve ① is opened.

When the pilot valve is opened and the pressure inside the pilot chamber ② decreases, resulting in the pressure difference from the inlet pressure. Then the diaphragm assembly ③ is lifted and the main valve ④ is opened.

<Valve opened – when there is no pressure or under very low minute pressure>

The armature assembly ⑦ and the diaphragm assembly ③ are connected with each other with the lift spring ⑩. When the armature assembly is attracted, the diaphragm assembly is pulled up and the main valve ④ is opened.

<Valve closed>

When the coil ⑨ is de-energised, the armature assembly ⑦ returns by the reacting force of the return spring ④ and the pilot valve ① is closed. When the pilot valve is closed, the pressure inside the pilot chamber ② increases, the resulting pressure difference between the inlet pressure side is lost and the main valve ④ is closed.

### Component Parts

No.	Description	Material	
		Brass body material (C37) specification	Stainless steel body material specification
1	<b>Body</b>	Brass	Stainless steel
2	<b>Bonnet</b>	Brass	Stainless steel
3	<b>Diaphragm assembly</b>	Stainless steel (NBR, FKM, EPDM)	
4	<b>Return spring</b>	Stainless steel	
5	<b>O-ring</b>	(NBR, FKM, EPDM)	
6	<b>Nut</b>	Brass	Brass, Ni plated
7	<b>Armature assembly</b>	Stainless steel	
8	<b>Tube assembly</b> <sup>Note)</sup>	Stainless steel, Cu	Stainless steel, Ag
9	<b>Solenoid coil</b>	—	
10	<b>Lift spring</b>	Stainless steel	
11	<b>Hexagon socket bolt</b>	Stainless steel	
12	<b>Name plate</b>	Aluminum	
13	<b>Clip</b>	SK	

The materials in parentheses are the seal materials.

Note) Cu and Ag are not applicable to the DC spec. and to the AC spec (Class B coil, Built-in full-wave rectifier).

### Normally open (N.O.)

Body material: Brass, Stainless steel

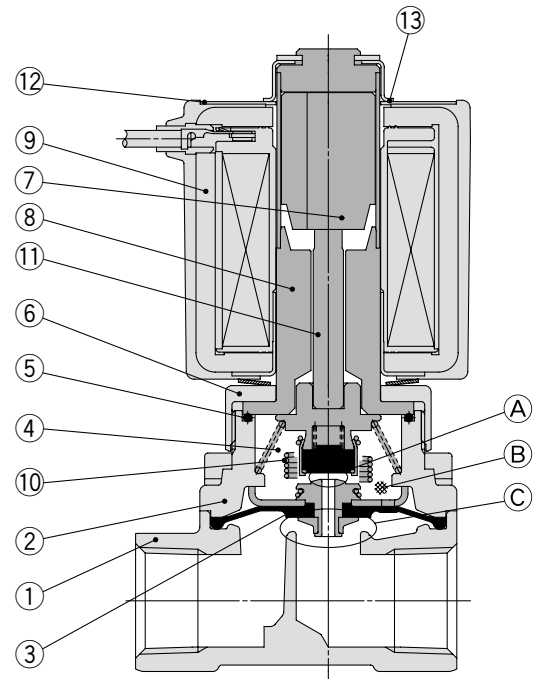

### Working principles

<Valve closed>

When the coil ⑨ is energised, the armature attached by the core of the tube assembly ⑧ closes the pilot valve ① via the push rod assembly ⑪.

When the pilot valve is closed, the pressure inside the pilot chamber ② increases, the resulting pressure difference between the inlet pressure side is lost and the main valve ④ is closed.

<Valve opened – when there is pressure>

The coil ⑨ is de-energised, the armature returns by the reacting force of the return spring ④ via the push rod assembly ⑪ and the pilot valve ① is opened.

When the pilot valve is opened, the pressure inside the chamber ② decreases, resulting in the pressure difference from the inlet pressure. Then the diaphragm assembly ③ is lifted and the main valve ④ is opened.

<Valve opened – when there is no pressure or under very low pressure>

The push rod assembly ⑪ and the diaphragm assembly ③ are connected with each other with the lift spring ⑩. When the push rod assembly returns, the diaphragm assembly is pulled up and the main valve ④ is opened.

### Component Parts

No.	Description	Material	
		Brass body material specification	Stainless steel body material specification
1	<b>Body</b>	Brass	Stainless steel
2	<b>Bonnet</b>	Brass	Stainless steel
3	<b>Diaphragm assembly</b>	Stainless steel (NBR, FKM, EPDM)	
4	<b>Return spring</b>	Stainless steel	
5	<b>O-ring</b>	(NBR)	(FKM, EPDM)
6	<b>Nut</b>	Brass	Brass, Ni plated
7	<b>Armature assembly</b>	Stainless steel	
8	<b>Tube assembly</b> <sup>Note)</sup>	Stainless steel, Cu	Stainless steel, Ag
9	<b>Solenoid coil</b>	—	
10	<b>Lift spring</b>	Stainless steel	
11	<b>Push rod assembly</b>	PPS, Stainless steel, (NBR)	Stainless steel, (FKM, EPDM)
12	<b>Name plate</b>	Aluminum	
13	<b>Cover</b>	Stainless steel	

**Dimensions/Body Material: Brass, Stainless Steel**

Normally closed (N.C.): VXZ22□0/VXZ23□0

Normally open (N.O.): VXZ22□2/VXZ23□2

Grommet: G

Conduit: C

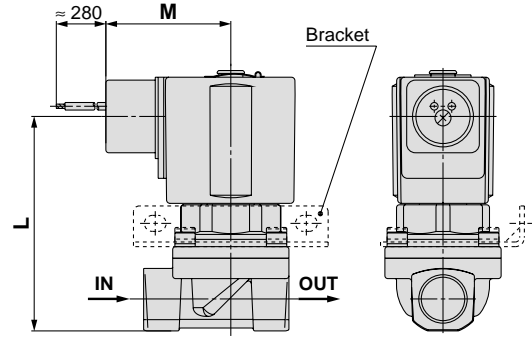
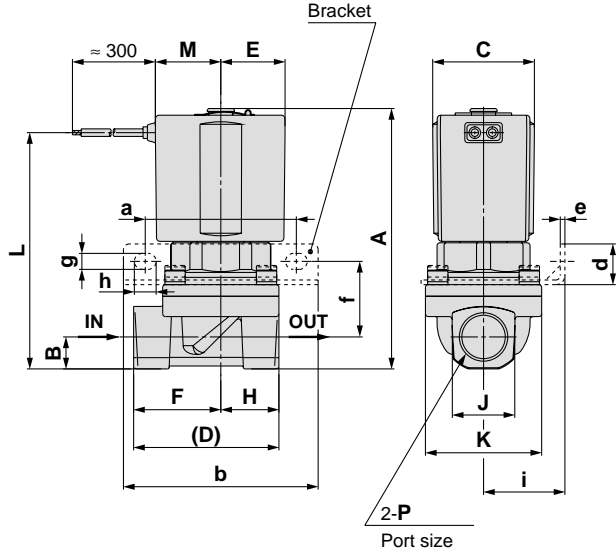

DIN terminal: D

Conduit terminal: T

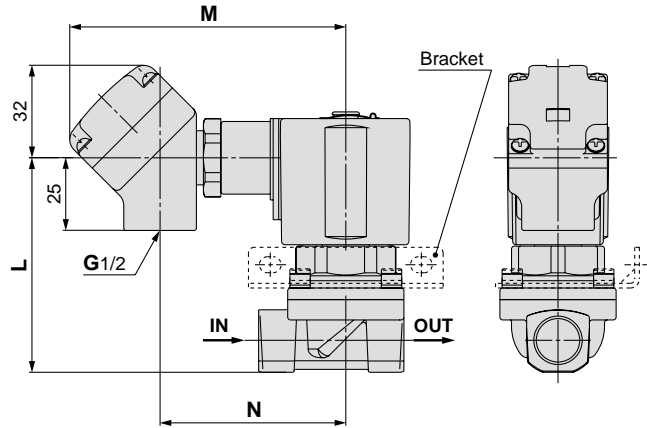
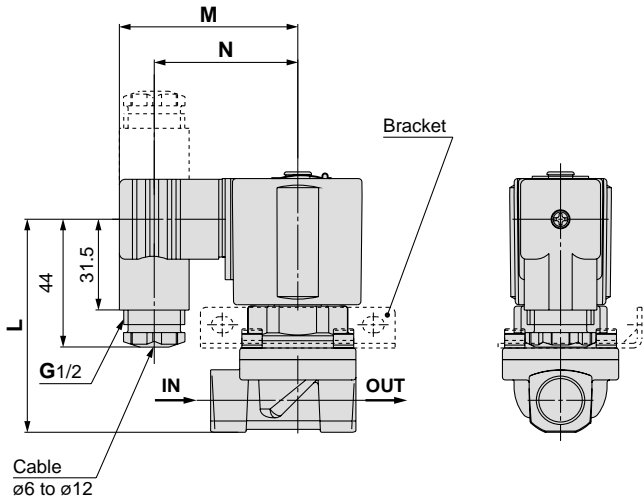

(mm)

Model		Port size P	A	B	C	D	E	F	H	J	K	Electrical entry (DC, AC/Class H coil)									
N.C.	N.O.											Grommet		Conduit		DIN terminal			Conduit terminal		
												L	M	L	M	L	M	N	L	M	N
VXZ2230	VXZ2232	1/4, 3/8	90 (97)	11	35	50	22.5	30	20	22	40	81.5 (83)	22.5	74 (75.5)	43	73.5 (75)	61.5	49.5	74 (75.5)	95	64
VXZ2240	VXZ2242	1/2	98 (105)	14	35	63	22.5	37	26	29.5	52	89.5 (91)	22.5	82 (83.5)	43	81.5 (83)	61.5	49.5	82 (83.5)	95	64
VXZ2350	VXZ2352	3/4	110 (117.5)	18	40	80	25	47.5	32.5	36	65	101.5 (103.5)	25.5	94 (96)	46	93.5 (95.5)	64	52	94 (96)	98	66.5
VXZ2360	VXZ2362	1/1	116.5 (123)	21	40	90	25	55	35	40.5	70	108 (109)	25.5	100.5 (101.5)	46	100 (101)	64	52	100.5 (101.5)	98	66.5

( ) denotes the value for N.O.

(mm)

Model		Port size P	a	b	d	e	f	g	h	i	Electrical entry (AC/Class B coil)*									
N.C.	N.O.										Grommet		Conduit		DIN terminal			Conduit terminal		
											L	M	L	M	L	M	N	L	M	N
VXZ2230	VXZ2232	1/4, 3/8	52	67	14	1.6	26	5.5	7.5	28	77.5(79)	33	72.5(74)	51.5	73.5(75)	68.5	56.5	72.5(74)	103.5	72.5
VXZ2240	VXZ2242	1/2	60	75	17	2.3	33	6.5	8.5	35	85.5(87)	33	80.5(82)	51.5	81.5(83)	68.5	56.5	80.5(82)	103.5	72.5
VXZ2350	VXZ2352	3/4	68	87	22	2.6	40	6.5	9	43	97.5(99.5)	36	92.5(94.5)	54	93.5(95.5)	71	59	92.5(94.5)	106	75
VXZ2360	VXZ2362	1/1	73	92	22	2.6	45.5	6.5	9	45	104(105)	36	99(100)	54	100(101)	71	59	99(100)	106	75

\* Coil with built-in full-wave rectifier (electrical option "R")

( ) denotes the value for N.O.

# Series VXZ22/23

For Air, Water, Oil

## Replacement Parts

### • Solenoid coil assembly part no.

DC

VX02 **2**N-**5**G-□

Series	
2	VXZ22□□
3	VXZ23□□

Rated voltage	Note
5	24 VDC
6	12 VDC

Note) Refer to the table (1) for the available combinations.

Symbol	Valve
-	N.C.
2	N.O.

Electrical entry

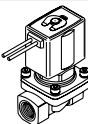
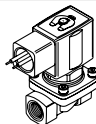
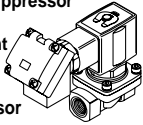
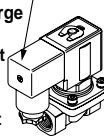
<b>G</b> - Grommet <b>GS</b> - With grommet surge voltage suppressor		<b>C</b> - Conduit	
<b>T</b> - With conduit terminal <b>TS</b> - With conduit terminal and surge voltage suppressor <b>TL</b> - With conduit terminal and light <b>TZ</b> - With conduit terminal, surge voltage suppressor and light		<b>D</b> - DIN terminal <b>DS</b> - DIN terminal with surge voltage suppressor <b>DL</b> - DIN terminal with light <b>DZ</b> - DIN terminal with surge voltage suppressor and light <b>DO</b> - For DIN terminal (without connector)	

\* Refer to the table (1) for the available combinations between each electrical option and rated voltage.

### AC/Class H coil (DIN terminal is not available.)

VX02 **2**N-**1**G-H-Z

Series	
2	VXZ22□□
3	VXZ23□□

Rated voltage	Note
1	100 VAC 50/60 Hz
2	200 VAC 50/60 Hz
3	110 VAC 50/60 Hz
4	220 VAC 50/60 Hz
7	240 VAC 50/60 Hz
8	48 VAC 50/60 Hz
J	230 VAC 50/60 Hz

Note) Refer to the table (1) for the available combinations.

Electrical entry

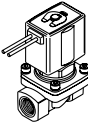
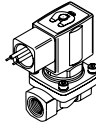
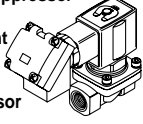
<b>G</b> - Grommet <b>GS</b> - With grommet surge voltage suppressor		<b>C</b> - Conduit	
<b>T</b> - With conduit terminal <b>TS</b> - With conduit terminal and surge voltage suppressor <b>TL</b> - With conduit terminal and light <b>TZ</b> - With conduit terminal, surge voltage suppressor and light			

\* Refer to the table (1) for the available combinations between each electrical option and rated voltage.

### AC/Class B coil (Built-in full-wave rectifier)

VX02 **2**N-**1**GR-□

Series	
2	VXZ22□□
3	VXZ23□□

Rated voltage	Note
1	100 VAC 50/60 Hz
2	200 VAC 50/60 Hz
3	110 VAC 50/60 Hz
4	220 VAC 50/60 Hz
7	240 VAC 50/60 Hz
8	48 VAC 50/60 Hz
J	230 VAC 50/60 Hz

Note) Refer to the table (1) for the available combinations.

Symbol	Valve
-	N.C.
2	N.O.

Electrical entry

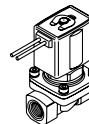
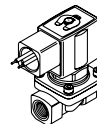
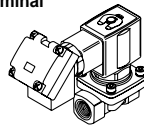
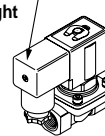
<b>G</b> - Grommet		<b>C</b> - Conduit	
<b>T</b> - With conduit terminal <b>TL</b> - With conduit terminal and light		<b>D</b> - DIN terminal <b>DL</b> - DIN terminal with light <b>DO</b> - For DIN terminal (without connector, gasket is included.)	

\* Refer to the table (1) for the available combinations between each electrical option and rated voltage.

\* The rectifier and the surge voltage suppressor are integrated as standard.

### • DIN connector part no.

Without electrical option **GDM2A**

With electrical option **GDM2A**-□□

Electrical option

**L** With light

\* Refer to the table (1) for the available combinations between each electrical option (S, L, Z) and rated voltage.

Rated voltage	
1	100 VAC, 110 VAC
2	200 VAC, 220 VAC, 230 VAC, 240 VAC
5	24 VDC
6	12 VDC
15	48 VAC

### • Gasket part no. for DIN connector

**VCW20-1-29-1**

Table (1) Rated Voltage – Electrical Option

AC/DC	Voltage symbol	Voltage	Class B			Class H		
			S	L	Z	S	L	Z
AC	1	100 V	—	●	—	●	●	●
	2	200 V	—	●	—	●	●	●
	3	110 V	—	●	—	●	●	●
	4	220 V	—	●	—	●	●	●
	7	240 V	—	—	—	●	—	—
	8	48 V	—	—	—	●	—	—
DC	5	24 V	●	●	●	DC spec. is not available.		
	6	12 V	●	—	—	DC spec. is not available.		

\* Option "S", "Z" are not available as a surge voltage suppressor is integrated into the AC/Class B coil, as standard.

\* Replacement of solenoid coils:

- DC and AC/Class H coils cannot be interchanged in order to change the voltage.
- DC and AC (built-in full-wave rectifier type) coils can be interchanged in order to change the voltage.
- All DC coil voltages are interchangeable.
- All AC coil voltages are interchangeable.
- Class B and H coils cannot be interchanged.

● Name plate part no.

**AZ-T-VX** Valve model

↑ Enter by referring to  
"How to Order"  
(Single Unit).

● Clip part no. (For N.C.)

For VXZ22: **VX022N-10**

For VXZ23: **VX023N-10**

● Clip part no. (For N.O.)

For VXZ22: **ETW-8**

For VXZ23: **ETW-9**

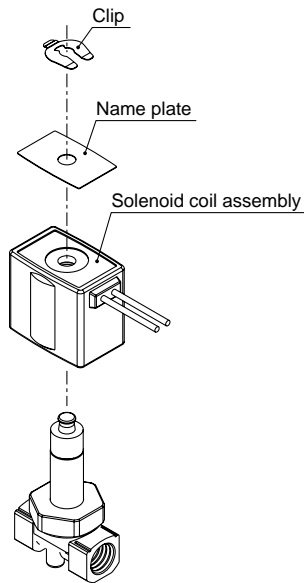

Specifications

For Air

For Water

For Oil

Construction

Dimensions

# Solenoid Valve Flow Characteristics

## (How to indicate flow characteristics)

### 1. Indication of flow characteristics

The flow characteristics in equipment such as a solenoid valve, etc. are indicated by their specifications as shown in Table (1).

Table (1) Indication of Flow Characteristics

Corresponding equipment	Indication by international standard	Other indications	Conformed standard
Pneumatic equipment	$C, b$	—	ISO 6358: 1989 JIS B 8390: 2000
	—	$S$	JIS B 8390: 2000 Equipment: JIS B 8373, 8374, 8375, 8379, 8381
		$C_v$	ANSI/(NFPA)T3.21.3: 1990
Process fluid control equipment	$A_v$	—	IEC60534-2-3: 1997 JIS B 2005: 1995
	—	$C_v$	Equipment: JIS B 8471, 8472, 8473

### 2. Pneumatic equipment

#### 2.1 Indication according to the international standards

(1) Conformed standard

**ISO 6358: 1989** : Pneumatic fluid power—Components using compressible fluids—  
Determination of flow-rate characteristics

**JIS B 8390: 2000** : Pneumatic fluid power—Components using compressible fluids—  
How to test flow-rate characteristics

(2) Definition of flow characteristics

The flow characteristics are indicated as a result of a comparison between sonic conductance  $C$  and critical pressure ratio  $b$ .

Sonic conductance  $C$  : Value which divides the passing mass flow rate of an equipment in a choked flow condition by the product of the absolute upstream pressure and the density in a standard condition.

Critical pressure ratio  $b$  : Choked flow will occur when the pressure ratio (downstream pressure/up stream pressure) is at or smaller than the critical pressure ratio.

Choked flow : The flow in which the upstream pressure is higher than the downstream pressure and where sonic speed is reached in a certain part of the equipment.  
Gaseous mass flow rate is in proportion to the upstream pressure and not dependent on the downstream pressure.

Subsonic flow : Flow when the pressure ratio is greater than the critical pressure ratio.

Standard condition : Air in a temperature state of 20°C, absolute pressure 0.1 MPa (= 100 kPa = 1 bar), relative humidity 65%.

It is stipulated by adding the "(ANR)" after the unit depicting air volume.  
(standard reference atmosphere)

Conformed standard: ISO 8778: 1990 Pneumatic fluid power—Standard reference atmosphere,  
JIS B 8393: 2000: Pneumatic fluid power—Standard reference atmosphere

(3) Formula for flow rate

It is described by the practical units as following.

When

$$\frac{P_2 + 0.1}{P_1 + 0.1} \leq b, \text{ choked flow}$$

$$Q = 600 \times C (P_1 + 0.1) \sqrt{\frac{293}{273 + t}} \dots\dots\dots(1)$$

When

$$\frac{P_2 + 0.1}{P_1 + 0.1} > b, \text{ subsonic flow}$$

$$Q = 600 \times C (P_1 + 0.1) \sqrt{1 - \left[ \frac{\frac{P_2 + 0.1}{P_1 + 0.1} - b}{1 - b} \right]^2} \sqrt{\frac{293}{273 + t}} \dots\dots\dots(2)$$

$Q$  : Air flow rate [dm<sup>3</sup>/min (ANR)], the SI unit dm<sup>3</sup> (Cubic decimetre) is also allowed to be described by ℓ (liter). 1 dm<sup>3</sup> = 1 ℓ

# Solenoid Valve Flow Characteristics

**C** : Sonic conductance [dm<sup>3</sup>/(s·bar)]

**b** : Critical pressure ratio [—]

**P<sub>1</sub>** : Upstream pressure [MPa]

**P<sub>2</sub>** : Downstream pressure [MPa]

**t** : Temperature [°C]

Note) Formula of subsonic flow is the elliptic analogous curve.

Flow characteristics are shown in Graph (1) For details, please make use of SMC's "Energy Saving Program".

Example)

Obtain the air flow rate when **P<sub>1</sub>** = 0.4 [MPa], **P<sub>2</sub>** = 0.3 [MPa], **t** = 20 [°C] for a solenoid valve where

**C** = 2 [dm<sup>3</sup>/(s·bar)] and **b** = 0.3.

According to formula (1), the maximum flow rate =  $600 \times 2 \times (0.4 + 0.1) \times \sqrt{\frac{293}{273 + 20}} = 600$  [dm<sup>3</sup>/min (ANR)]

Pressure ratio =  $\frac{0.3 + 0.1}{0.4 + 0.1} = 0.8$

Based on Graph (1), the flow rate ratio is going to be 0.7 if it is read with a pressure ratio of 0.8 and the flow ratio of **b** = 0.3.

Hence, flow rate = Max. flow rate x flow rate ratio = 600 x 0.7 = 420 [dm<sup>3</sup>/min (ANR)]

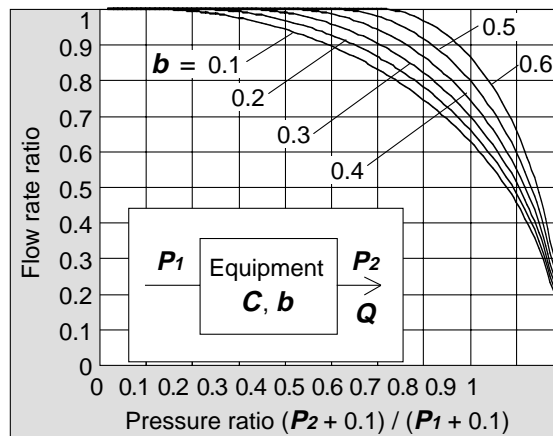

Graph (1) Flow characteristics

#### (4) Test method

Pipe the test equipment to the test circuit shown in Fig. (1). Keep the upstream pressure at a certain constant level above 0.3MPa. First measure the maximum flow rate in saturation. Then, measure the flow rate, upstream pressure and downstream pressure each at 80%, 60%, 40% and 20% points of the flow rate. Calculate the sonic conductance **C** from the maximum flow rate. Also, substitute other data for variables in the formula for subsonic flow and obtain the critical pressure rate **b** by averaging the critical pressure rates at those points.

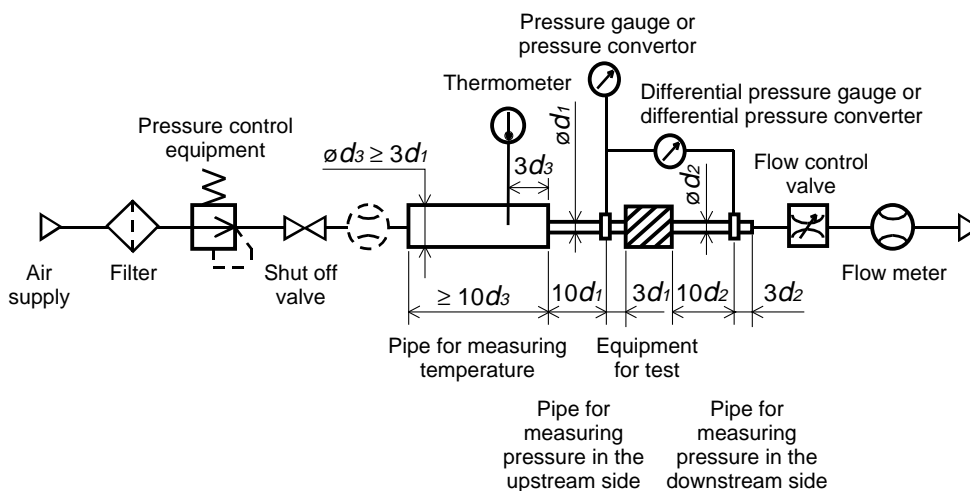

Fig. (1) Test circuit based on ISO 6358, JIS B 8390

# Solenoid Valve Flow Characteristics

## 2.2 Effective area **S**

(1) Conformed standard

**JIS B 8390: 2000: Pneumatic fluid power—Components using compressible fluids—  
Determination of flow rate characteristics**

**Equipment standards: JIS B 8373: 2 port solenoid valve for pneumatics**

**JIS B 8374: 3 port solenoid valve for pneumatics**

**JIS B 8375: 4 port, 5 port solenoid valve for pneumatics**

**JIS B 8379: Silencer for pneumatics**

**JIS B 8381: Fittings of flexible joint for pneumatics**

(2) Definition of flow characteristics

Effective area **S**: The flow ability of a component, represented by its equivalent "ideal" cross section area. This effective area is calculated under sonic conditions by measuring pressure loss in an air tank. Like sonic conductance **C**, the effective area is a method of expressing the flow rate of a product.

(3) Formula for flow rate

When

$$\frac{P_2 + 0.1}{P_1 + 0.1} \leq 0.5, \text{ choked flow}$$

$$Q = 120 \times S (P_1 + 0.1) \sqrt{\frac{293}{273 + t}} \dots \dots \dots (3)$$

When

$$\frac{P_2 + 0.1}{P_1 + 0.1} > 0.5, \text{ subsonic flow}$$

$$Q = 240 \times S \sqrt{(P_2 + 0.1)(P_1 - P_2)} \sqrt{\frac{293}{273 + t}} \dots \dots \dots (4)$$

Conversion with sonic conductance **C**:

$$S = 5.0 \times C \dots \dots \dots (5)$$

**Q** : Air flow rate [dm<sup>3</sup>/min(ANR)], dm<sup>3</sup> (cubic decimetre) is also allowed to be described by ℓ (liter) 1 dm<sup>3</sup> = 1 ℓ

**S** : Effective area [mm<sup>2</sup>]

**P<sub>1</sub>** : Upstream pressure [MPa]

**P<sub>2</sub>** : Downstream pressure [MPa]

**t** : Temperature [°C]

Note) Formula for subsonic flow (4) is only applicable when the critical pressure ratio **b** is unknown. It is the same as the formula for sonic conductance **C** (2) only when **b**=0.5.

(4) Test method

Pipe the test equipment to the test circuit shown in Fig. (2). Fill the air tank with compressed air and keep the pressure at a constant level above 0.6MPa (0.5 MPa). Then discharge the air until the pressure in the tank drops to 0.25MPa (0.2 MPa). Measure the time required to discharge the air and the residual pressure in the air tank after leaving it until the pressure becomes stable in order to calculate the effective sectional area **S** by the following formula. Select the capacity of the air tank according to the effective sectional area of the test equipment. In the case of JIS B 8373, 8374, 8375, 8379, 8381, the pressure values are in parentheses and the coefficient of formula is 12.9.

$$S = 12.1 \frac{V}{t} \log_{10} \left( \frac{P_s + 0.1}{P + 0.1} \right) \frac{293}{T} \dots \dots \dots (6)$$

**S** : Effective area [mm<sup>2</sup>]

**V** : Air tank capacity [dm<sup>3</sup>]

**t** : Discharging time [s]

**P<sub>s</sub>** : Pressure inside air tank before discharging [MPa]

**P** : Residual pressure inside air tank after discharging [MPa]

**T** : Temperature inside air tank before discharging [K]

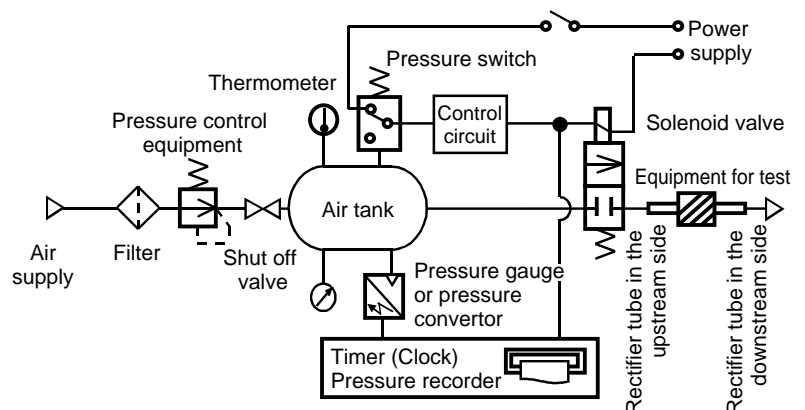

Fig. (2) Test circuit based on JIS B 8390

# Solenoid Valve Flow Characteristics

## 2.3 Flow coefficient $C_v$ factor

### The United States Standard ANSI(NFPA)T3.21.3:1990: Pneumatic fluid power—Flow rating test procedure and reporting method for fixed orifice components

Defines the of flow coefficient  $C_v$  factor by the following formula which is based on testing conducted with a test circuit analogous to ISO 6358.

$$C_v = \frac{Q}{114.5 \sqrt{\frac{\Delta P (P_2 + P_a)}{T_1}}} \dots\dots\dots(7)$$

$\Delta P$  : Pressure drop between the static pressure tapping ports [bar]

$P_1$  : Pressure of the upstream tapping port [bar gauge]

$P_2$  : Pressure of the downstream tapping port [bar gauge]:  $P_2 = P_1 - \Delta P$

$Q$  : Flow rate [dm<sup>3</sup>/s standard condition]

$P_a$  : Atmospheric pressure [bar absolute]

$T_1$  : Upstream absolute temperature [K]

Test conditions are  $< P_1 + P_a = 6.5 \pm 0.2$  bar absolute,  $T_1 = 297 \pm 5$ K,  $0.07 \text{ bar} \leq \Delta P \leq 0.14$  bar.

This is the same concept as effective area  $A$  which ISO6358 stipulates as being applicable only when the pressure drop is smaller in relation to the upstream pressure so that the compression of air is negligible.

## 3. Process fluid control equipment

(1) Conformed standard

**IEC60534-2-3: 1997: Industrial process control valves. Part 2: Flow capacity, Section Three-Test procedures**

**JIS B 2005: 1995: Test method for the flow coefficient of a valve**

**Equipment standards: JIS B 8471: Solenoid valve for water**

**JIS B 8472: Solenoid valve for steam**

**JIS B 8473: Solenoid valve for fuel oil**

(2) Definition of flow characteristics

**$A_v$  factor:** It is the value representing the flow of clean water in m<sup>3</sup>/s which runs through a valve (equipment for test) when the pressure difference is 1 Pa. It is calculated using the following formula.

$$A_v = Q \sqrt{\frac{\rho}{\Delta P}} \dots\dots\dots(8)$$

**$A_v$ :** Flow coefficient [m<sup>2</sup>]

**$Q$ :** Flow rate [m<sup>3</sup>/s]

**$\Delta P$ :** Pressure difference [Pa]

**$\rho$ :** Density of fluid [kg/m<sup>3</sup>]

(3) Formula of flow rate

It is described by the practical units. Also, the flow characteristics are shown in Graph (2).

In the case of liquid:

$$Q = 1.9 \times 10^6 A_v \sqrt{\frac{\Delta P}{G}} \dots\dots\dots(9)$$

**$Q$ :** Flow rate [ℓ/min]

**$A_v$ :** Flow coefficient [m<sup>2</sup>]

**$\Delta P$ :** Pressure difference [MPa]

**$G$ :** Relative density [water = 1]

# Solenoid Valve Flow Characteristics

Conversion of flow coefficient:

$$Av = 28 \times 10^{-6} Kv = 24 \times 10^{-6} Cv \dots\dots\dots(10)$$

Here,

**Kv** factor: It is the value representing the flow rate of clean water in m<sup>3</sup>/h which runs through a valve at 5 to 40°C, when the pressure difference is 1 bar.

**Cv** factor (Reference values): It is the value representing the flow rate of clean water in US gal/min which runs through a valve at 60°F, when the pressure difference is 1 lbf/in<sup>2</sup> (psi).

Value is different from **Kv** and **Cv** factors for pneumatic purpose due to different test method.

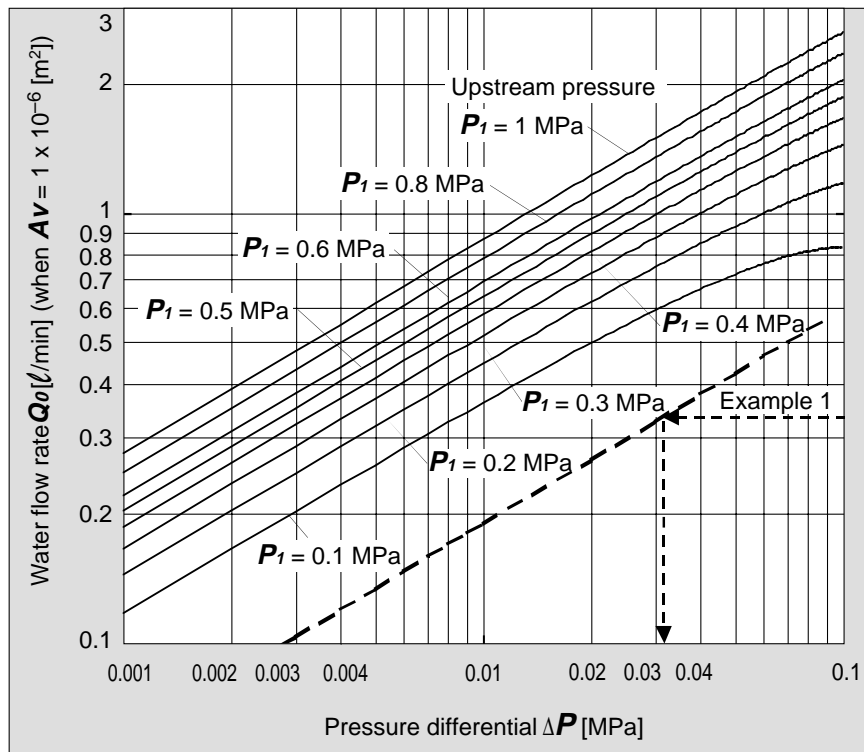

**Graph (2) Flow characteristics**

Example 1)

Obtain the pressure difference 15 [l/min] of water runs through a solenoid valve with an  $Av = 45 \times 10^{-6} [m^2]$ . Since  $Q_0 = 15/45 = 0.33 [l/min]$ , according to Graph (2), if reading  $\Delta P$  when  $Q_0$  is 0.33, it will be 0.031 [MPa].

(4) Test method

Attach a test equipment with the test circuit shown in Fig. (3). then, run water at 5 to 40°C, and measure the flow rate with a pressure difference of 0.075 MPa. However, the pressure difference needs to be set with a large enough difference so that the Reynolds number does not go below a range of  $4 \times 10^4$ .

By substituting the measurement results for formula (8) to figure out **Av**.

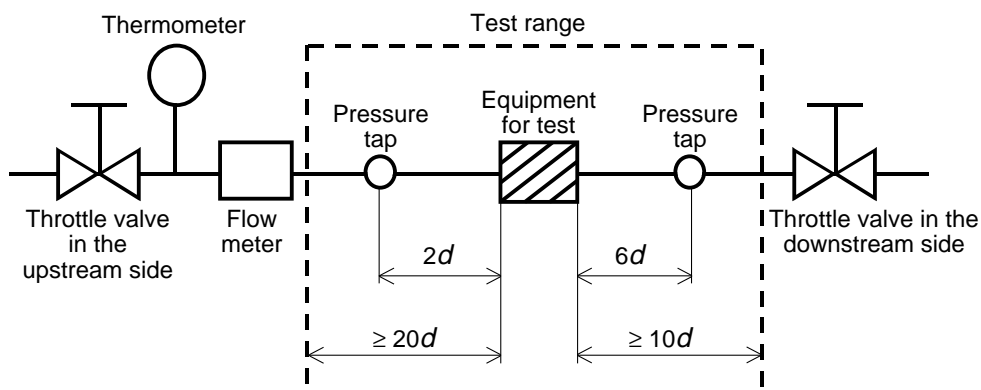
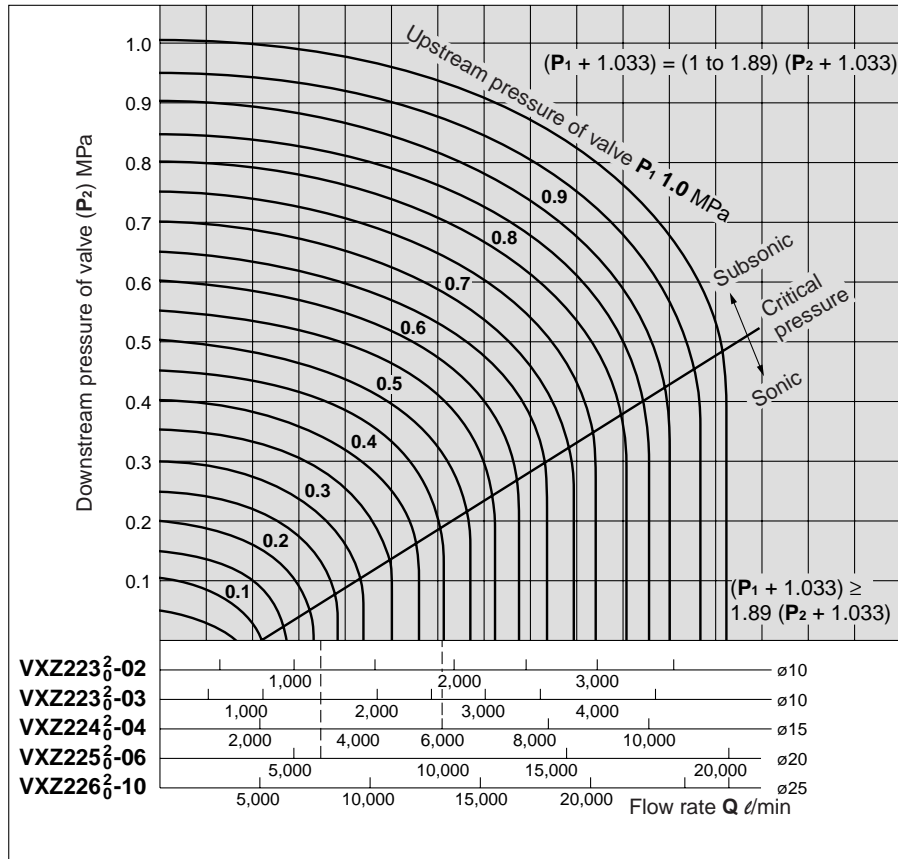

**Fig. (3) Test circuit based on IEC60534-2-3, JIS B 2005**

# Flow Characteristics

Note) Use this graph as a guide. In the case of obtaining an accurate flow rate, refer to pages 14 through to 18.

## For Air



### How to read the graph

The sonic range pressure to generate a flow rate of 6,000 l/min (ANR) is  $P_1 \approx 0.47$  MPa for a  $\phi 15$  orifice (VXZ224 $\frac{2}{3}$ -04) and  $P_1 \approx 0.23$  MPa for a  $\phi 20$  orifice (VXZ225 $\frac{2}{3}$ -06).

## For Water

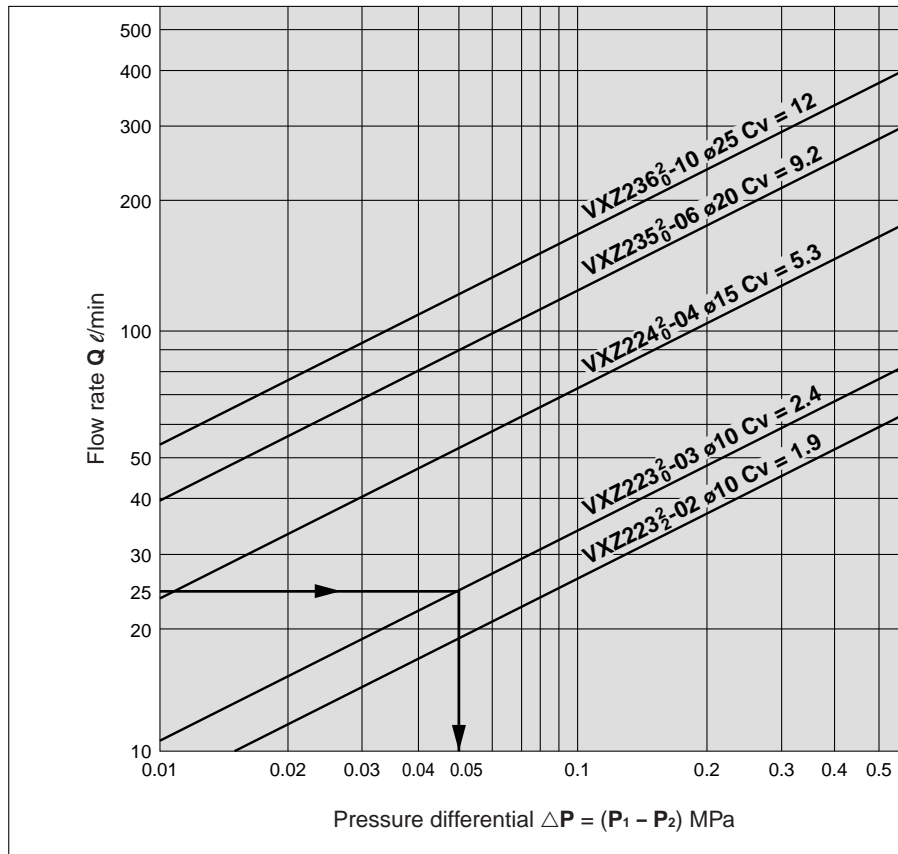

### How to read the graph

When a water flow of 25 l/min is generated,  $\Delta P \approx 0.05$  MPa for a valve with  $\phi 10$  orifice (VXZ223 $\frac{2}{3}$ -03).

# Glossary of Terms

## Pressure Terminology

### 1. Maximum operating pressure differential

The maximum pressure differential (the difference between the inlet and outlet pressure) which is allowed for operation, with the valve closed or open. When the outlet pressure is 0 MPa, this becomes the maximum operating pressure.

### 2. Minimum operating pressure differential

The minimum pressure differential (the difference between the inlet pressure and outlet pressure) required to keep the main valve fully opened.

### 3. Maximum system pressure

The maximum pressure that can be applied inside the pipelines (line pressure).  
(The pressure differential of the solenoid valve portion must be less than the maximum operating pressure differential.)

### 4. Withstand pressure

The pressure in which the valve must be withstood without a drop in performance after holding for one minute under prescribed pressure and returning to the operating pressure range. (value under the prescribed conditions)

## Electrical Terminology

### 1. Apparent power (VA)

Volt-ampere is the product of voltage (V) and current (A). Power consumption (W): For AC,  $W = V \cdot A \cdot \cos\theta$ . For DC,  $W = V \cdot A$ .

(Note)  $\cos\theta$  shows power factor.  $\cos\theta = 0.6$

### 2. Surge voltage

A high voltage which is momentarily generated by shutting off the power in the shut-off area.

### 3. Enclosure

A degree of protection defined in the "JIS C 0920: Waterproof test of electric machinery/appliance and the degree of protection against the intrusion of solid foreign objects".

IP65: Dust-tight, Low jetproof type

"Low jetproof type" means that no water intrudes inside the equipment that could hinder it from operating normally by means of applying water for 3 minutes in the prescribed manner. Take appropriate protection measures, since a device is not usable in an environment where a droplet of water is splashed.

## Others

### 1. Material

NBR: Nitrile rubber

FKM: Fluoro rubber – Trade names: Viton®, Dai-el®, etc.

EPDM: Ethylene propylene rubber

### 2. Oil-free treatment

The degreasing and washing of wetted parts.

### 3. Passage symbol

In the JIS symbol (止動符) IN and OUT are in a blocked condition (止), but actually in the case of reverse pressure (OUT>IN), there is a limit to the blocking.

(◇) is used to indicate that blocking of reverse pressure is not possible.





## Series VXZ22/23

# Safety Instructions

The following safety instructions are intended to prevent a hazardous situation and/or equipment damage. These instructions indicate the level of potential hazard by all safety practices, including labels of "**Caution**", "**Warning**" or "**Danger**". To ensure safety, please observe ISO 4414 <sup>Note 1</sup>), JIS B 8370 <sup>Note 2</sup>).

 **Caution:** Operator error could result in injury or equipment damage.

 **Warning:** Operator error could result in serious injury or loss of life.

 **Danger :** In extreme conditions, there is a possible result of serious injury or loss of life.

Note 1) ISO 4414: Pneumatic fluid power – General rules relating to systems

Note 2) JIS B 8370: General Rules for Pneumatic Equipment

### **Warning**

#### **1. The compatibility of equipment is the responsibility of the person who designs the system or decides its specifications.**

Since the products specified here are used in various operating conditions, their compatibility with a specific system must be based on specifications, post analysis and/or tests to meet a specific requirement. The expected performance and safety assurance will be the responsibility of the person who has determined the compatibility of the system. This person should continuously review the suitability of all items specified, referring to the latest catalogue information and taking into consideration the possibility of equipment failure when configuring a system. Be particularly careful in determining the compatibility with the fluid to be used.

#### **2. Only trained personnel should operate machinery and equipment.**

The fluid can be dangerous if handled incorrectly. Assembly, handling or maintenance of the system should be performed by trained and experienced operators.

#### **3. Do not service machinery/equipment or attempt to remove components until the safety is confirmed.**

1. Inspection and maintenance of machinery/equipment should only be performed once measures to prevent falling or runaway of the driven object have been confirmed. Measures to prevent danger from a fluid should also be confirmed.

2. When equipment is to be removed, confirm the safety processes mentioned above, release the fluid pressure and be certain there is no danger from fluid leakage or fluid remaining in the system.

3. Carefully restart the machinery, confirming that safety measures are being implemented.

#### **4. Contact SMC if the product is to be used in any of the following conditions:**

1. Conditions and environments beyond the given specifications, or if product is used outdoors.

2. With fluids whose application causes concern due to the type of fluid or additives, etc.

3. An application which has the possibility of having a negative effect on people, property, and therefore requires special safety analysis.



# 2 Port Solenoid Valve for Fluid Control

## Precautions 1

Be sure to read this before handling.

For detailed precautions on each series, refer to the main text.

### Design

#### Warning

##### 1. Cannot be used as an emergency shutoff valve, etc.

The valves presented in this catalogue are not designed for safety applications such as an emergency shutoff valve. If the valves are used in this type of system, other reliable safety assurance measures should also be adopted.

##### 2. Extended periods of continuous energisation

The solenoid coil will generate heat when continuously energised. Avoid using in a tightly shut container. Install it in a well-ventilated area. Furthermore, do not touch it while it is being energised or right after it is energised.

##### 3. This solenoid valve cannot be used for explosion proof applications.

##### 4. Maintenance space

The installation should allow sufficient space for maintenance activities.

##### 5. Liquid rings

In cases with a flowing liquid, provide a by-pass valve in the system to prevent the liquid from entering the liquid seal circuit.

##### 6. Actuator drive

When an actuator, such as a cylinder, is to be driven using a valve, take appropriate measures to prevent potential danger caused by actuator operation.

##### 7. Pressure (including vacuum) holding

It is not usable for an application such as holding the pressure (including vacuum) inside of a pressure vessel because air leakage is entailed in a valve.

##### 8. When the conduit type is used as equivalent to an IP65 enclosure, install a wiring conduit, etc.

##### 9. When an impact, such as water hammer, etc., caused by the rapid pressure fluctuation is applied, the solenoid valve may be damaged. Please pay attention to this.

### Selection

#### Warning

##### 1. Confirm the specifications.

Give careful consideration to the operating conditions such as the application, fluid and environment, and use within the operating ranges specified in this catalogue.

##### 2. Fluid

###### 1. Type of fluid

Before using a fluid, confirm whether it is compatible with the materials from each model by referring to the fluids listed in this catalogue. Use a fluid with a kinematic viscosity of 50 mm<sup>2</sup>/s or less. If there is something you do not know, please contact SMC.

###### 2. Flammable oil, Gas,

Confirm the specification for leakage in the interior and/or exterior area.

### Selection

#### Warning

##### 3. Corrosive gas

Cannot be used since it will lead to cracks by stress corrosion or result in other incidents.

##### 4. Use an oil-free specification when oily particles must not enter the fluid passage.

##### 5. Applicable fluid on the list may not be used depending on the operating condition. Just because the compatibility list shows the general case, still give adequate confirmation when selecting a model.

##### 3. Fluid quality

The use of a fluid which contains foreign matter can cause problems such as malfunction and seal failure by promoting wear of the valve seat and armature, and by sticking to the sliding parts of the armature, etc. Install a suitable filter (strainer) immediately upstream from the valve. As a general rule, use 80 to 100 mesh.

When used to supply water to boilers, substances such as calcium and magnesium which generate hard scale and sludge are included. Since this scale and sludge can cause the valve to malfunction, install water softening equipment, and a filter (strainer) directly upstream from the valve to remove these substances.

##### 4. Air quality

###### 1. Use clean air.

Do not use compressed air which includes chemicals, synthetic oils containing organic solvents, salt or corrosive gases, etc., as it can cause damage or malfunction.

###### 2. Install air filters.

Install air filters close to the valves on their upstream side. A filtration degree of 5 µm or less should be selected.

###### 3. Install an air dryer or after cooler, etc.

Compressed air that includes excessive drainage may cause malfunction of valves and other pneumatic equipment. To prevent this, install an air dryer or after cooler, etc.

###### 4. If excessive carbon powder is generated, eliminate it by installing mist separators on the upstream side of the valves.

If excessive carbon powder is generated by the compressor, it may adhere to the inside of the valves and cause a malfunction.

Refer to SMC's Best Pneumatics catalogue for further details on compressed air quality.

##### 5. Ambient environment

Use within the operable ambient temperature range. Confirm the compatibility between the product's composition materials and the ambient atmosphere. Be sure that the fluid used does not touch the external surface of the product.

##### 6. Countermeasures against static electricity

Take measures to prevent static electricity since some fluids can cause static electricity.

##### 7. For the low particle generation specification, please contact SMC.

##### 8. Minimum differential operating pressure

Even if the differential pressure is greater than the minimum differential operating pressure when the valve is closed, it may become lower than the minimum differential operating pressure when the valve is open due to restrictors in the piping of the supply source (such as a pump, compressor, etc.). Please exercise caution.



# 2 Port Solenoid Valve for Fluid Control Precautions 2

Be sure to read this before handling.

For detailed precautions on each series, refer to the main text.

## Selection

### ⚠ Caution

#### 1. Leakage voltage

Particularly when using a resistor in parallel with a switching element and using a C-R element (surge voltage suppressor) to protect the switching element, take note that leakage current will flow through the resistor, C-R element, etc., creating a possible danger that the valve may not turn off.

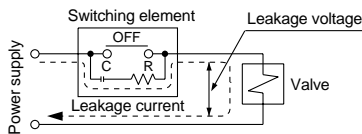

AC coil: 20% or less of rated voltage

DC coil: 2% or less of rated voltage

#### 2. Low temperature operation

1. The valve can be used in an ambient temperature of between  $-10$  to  $-20^{\circ}\text{C}$ . However, take measures to prevent freezing or solidification of impurities, etc.
2. When using valves for water application in cold climates, take appropriate countermeasures to prevent the water from freezing in tubing after cutting the water supply from the pump, by draining the water, etc. When warming by a heater, etc., be careful not to expose the coil portion to a heater. Installation of a dryer, or heat retaining of the body is recommended to prevent a freezing condition in which the dew point temperature is high and the ambient temperature is low, and the high flow runs.

## Mounting

### ⚠ Warning

#### 1. If air leakage increases or equipment does not operate properly, stop operation.

After mounting is completed, confirm that it has been done correctly by performing a suitable function test.

#### 2. Do not apply external force to the coil section.

When tightening is performed, apply a wrench or other tool to the outside of the piping connection parts.

#### 3. Be sure not to position the coil downwards.

When mounting a valve with its coil positioned downwards, foreign objects in the fluid will adhere to the iron core leading to a malfunction.

#### 4. Do not warm the coil assembly with a heat insulator, etc.

Use tape, heaters, etc., for freeze prevention on the piping and body only. They can cause the coil to burn out.

#### 5. Secure with brackets, except in the case of steel piping and copper fittings.

#### 6. Avoid sources of vibration, or adjust the arm from the body to the minimum length so that resonance will not occur.

#### 7. Painting and coating

Warnings or specifications printed or labelled on the product should not be erased, removed or covered up.

## Piping

### ⚠ Caution

#### 1. Preparation before piping

Before piping is connected, it should be thoroughly blown out with air (flushing) or washed to remove chips, cutting oil and other debris from inside the pipe.

Install piping so that it does not apply pulling, pressing, bending or other forces on the valve body.

#### 2. Wrapping of pipe tape

When connecting pipes, fittings, etc., be sure that chips from the pipe threads and sealing material do not enter the valve.

Furthermore, when pipe tape is used, leave 1.5 to 2 thread ridges exposed at the end of the threads.

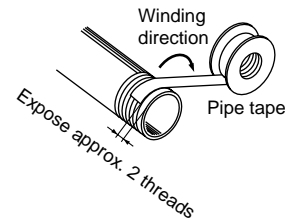

#### 3. Avoid connecting ground lines to piping, as this may cause electric corrosion of the system.

#### 4. Always tighten threads with the proper tightening torque.

When attaching fittings to valves, tighten with the proper tightening torque shown below.

#### Tightening Torque for Piping

Connection threads	Proper tightening torque N·m
Rc 1/8	7 to 9
Rc 1/4	12 to 14
Rc 3/8	22 to 24
Rc 1/2	28 to 30

#### 5. Connection of piping to products

When connecting piping to a product, refer to its instruction manual to avoid mistakes regarding the supply port, etc.

#### 6. Steam generated in a boiler contains a large amount of drainage.

Be sure to operate it with a drain trap installed.

#### 7. In applications such as vacuum and non-leak specifications, use caution specifically against the contamination of foreign matters or airtightness of the fittings.

#### 8. If a regulator is directly connected to a solenoid valve, their interaction will cause them to enter a state of resonance. In some cases, this will result in chattering.



# 2 Port Solenoid Valve for Fluid Control

## Precautions 3

Be sure to read this before handling.  
For detailed precautions on each series, refer to the main text.

### Wiring

#### ⚠ Caution

- As a rule, use electrical wire with a cross sectional area of 0.5 to 1.25 mm<sup>2</sup> for wiring. Furthermore, do not allow excessive force to be applied to the lines.
- Use electrical circuits which do not generate chattering in their contacts.
- Use voltage which is within  $\pm 10\%$  of the rated voltage. In cases with a DC power supply where importance is placed on responsiveness, stay within  $\pm 5\%$  of the rated value. The voltage drop is the value in the lead wire section connecting the coil.
- When a surge from the solenoid affects the electrical circuitry, install a surge absorber, etc., in parallel with the solenoid. Or, adopt the option that comes with the surge voltage protection circuit. (However, a surge voltage occurs even if the surge voltage protection circuit is used. For details, please contact SMC.)

### Electrical Connections

#### ⚠ Caution

##### Grommet

Class H coil: AWG18 Insulator O.D. 2.2 mm  
Class B coil: AWG20 Insulator O.D. 2.5 mm

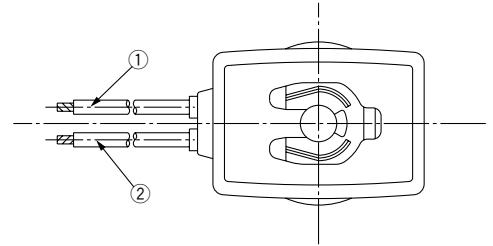

Rated voltage	Lead wire colour	
	①	②
DC (Class B only)	Black	Red
100 VAC	Blue	Blue
200 VAC	Red	Red
Other AC	Gray	Gray

\* There is no polarity.

##### DIN terminal (Class B only)

Since internal connections are as shown below for the DIN terminal, make connections to the power supply accordingly.

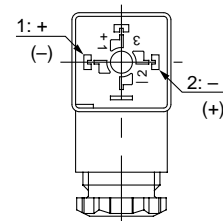

Terminal no.	1	2
DIN terminal	+ (-)	- (+)

\* There is no polarity.

- Use compatible heavy duty cords with cable O.D. of  $\phi 6$  to 12 mm.
- Use the tightening torques below for each section.

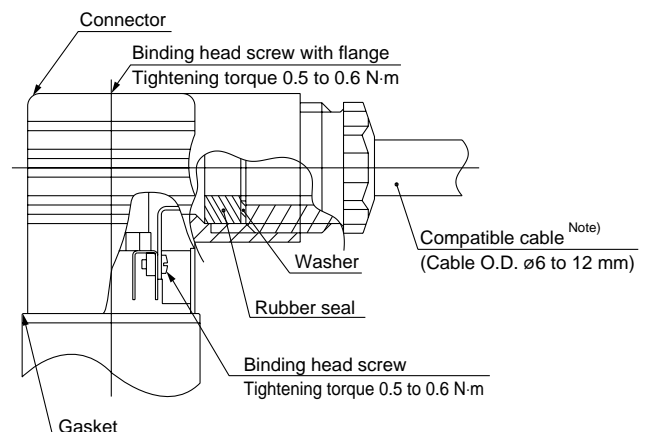

Note) For an outside cable diameter of  $\phi 9$  to 12 mm, remove the internal parts of the rubber seal before using.



# 2 Port Solenoid Valve for Fluid Control

## Precautions 4

Be sure to read this before handling.

For detailed precautions on each series, refer to the main text.

### Electrical Connections

#### Caution

##### Conduit terminal

In the case of the conduit terminal, make connections according to the marks shown below.

- Use the tightening torques below for each section.
- Properly seal the terminal connection (G1/2) with the special wiring conduit, etc.

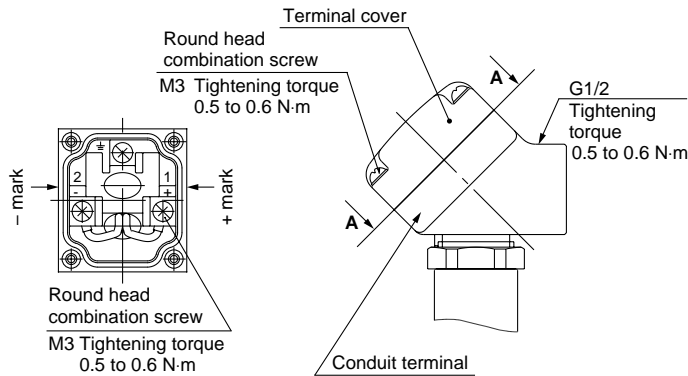

#### View A-A

(Internal connection diagram)

##### Conduit

When used as an IP65 equivalent, use seal (part no. VCW20-15-6) to install the wiring conduit. Also, use the tightening torque below for the conduit.

Class H coil: AWG18 Insulator O.D. 2.2 mm  
 Class B coil: AWG20 Insulator O.D. 2.5 mm

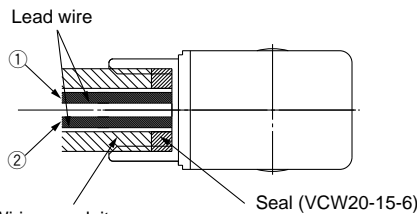

Wiring conduit  
 (Bore size G1/2)  
 Tightening torque 0.5 to 0.6 N·m

Rated voltage	Lead wire colour	
	①	②
DC	Black	Red
100 VAC	Blue	Blue
200 VAC	Red	Red
Other AC	Gray	Gray

\* There is no polarity for DC.

Description	Part no.
Seal	VCW20-15-6

Note) Please order separately.

### Electrical Circuits

#### Caution

##### [DC circuit]

Grommet, Conduit,  
 Conduit terminal,  
 DIN type

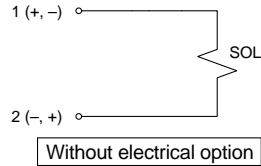

Grommet, Conduit terminal,  
 DIN type

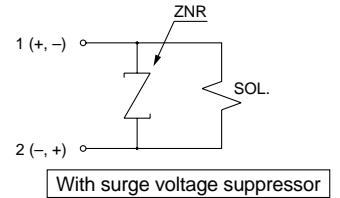

Conduit terminal,  
 DIN type

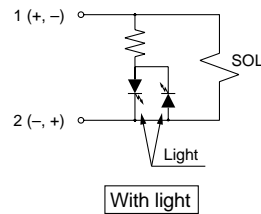

Conduit terminal,  
 DIN type

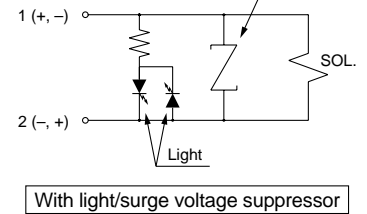

##### [AC, Class B (Built-in full wave rectifier type) circuit]

\* For AC/Class B, the standard product is equipped with a surge voltage suppressor.

Grommet, Conduit,  
 Conduit terminal,  
 DIN type

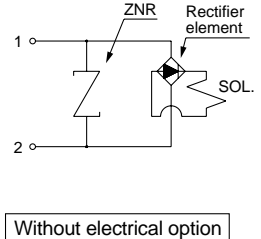

Conduit terminal,  
 DIN type

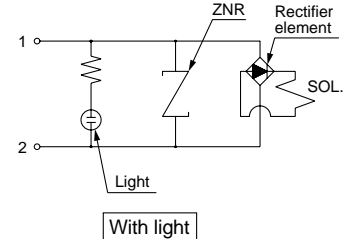

##### [AC, Class B/H circuit]

Grommet, Conduit,  
 Conduit terminal

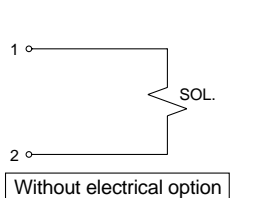

Grommet,  
 Conduit terminal

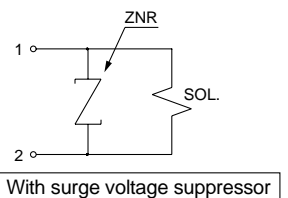

Conduit terminal

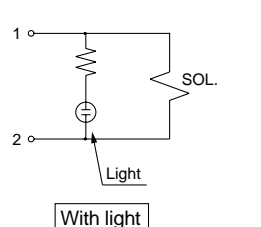

Conduit terminal

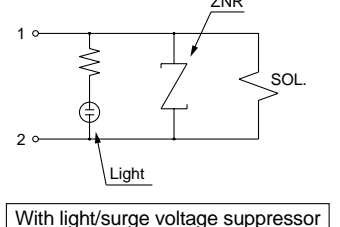



# 2 Port Solenoid Valve for Fluid Control Precautions 5

Be sure to read this before handling.  
For detailed precautions on each series, refer to the main text.

## Operating Environment

### Warning

1. Do not use the valves in an atmosphere having corrosive gases, chemicals, salt water, water steam, or where there is direct contact with any of these.
2. Do not use in explosive atmospheres.
3. Do not use in locations subject to vibration or impact.
4. Do not use in locations where radiated heat will be received from nearby heat sources.
5. Employ suitable protective measures in locations where there is contact with water droplets, oil or welding spatter, etc.

## Lubrication

### Caution

1. This solenoid valve can be operated without lubrication.

If a lubricant is used in the system, use turbine oil Class 1, ISO VG32 (with no additive). But do not lubricate a valve with EPDM seal.

Refer to the table of brand name of lubricants compliant with Class 1 turbine oil (with no additive), ISO VG32.

#### Class 1 Turbine Oil (with no additive), ISO VG32

Classification of viscosity (cst) (40°C)	Viscosity according to ISO Grade	32
Idemitsu Kosan Co.,Ltd.		Turbine oil P-32
Nippon Oil Corp.		Turbine oil 32
Cosmo Oil Co.,Ltd.		Cosmo turbine 32
Japan Energy Corp.		Kyodo turbine 32
Kygnus Oil Co.		Turbine oil 32
Kyushu Oil Co.		Stork turbine 32
Nippon Oil Corp.		Mitsubishi turbine 32
Showa Shell Sekiyu K.K.		Turbine 32
Tonen General Sekiyu K.K.		General R turbine 32
Fuji Kosan Co.,Ltd.		Fucoal turbine 32

Please contact SMC regarding Class 2 turbine oil (with additives), ISO VG32.

## Maintenance

### Warning

#### 1 Removing the product

The valve will reach a high temperature when used with high temperature fluids. Confirm that the valve temperature has dropped sufficiently before performing work. If touched inadvertently, there is a danger of being burned.

1. Shut off the fluid supply and release the fluid pressure in the system.
2. Shut off the power supply.
3. Dismount the product.

#### 2. Low frequency operation

Switch valves at least once every 30 days to prevent malfunction. Also, in order to use it under the optimum state, conduct a regular inspection once a half year.

## Maintenance

### Caution

#### 1. Filters and strainers

1. Be careful regarding clogging of filters and strainers.
2. Replace filter elements after one year of use, or earlier if the pressure drop reaches 0.1 MPa.
3. Clean strainers when the pressure drop reaches 0.1 MPa.

#### 2. Lubrication

When using with lubrication, never forget to lubricate continuously.

#### 3. Storage

In case of long term storage after use with heated water, thoroughly remove all moisture to prevent rust and deterioration of rubber materials, etc.

#### 4. Exhaust the drain from an air filter periodically.

## Operating Precautions

### Warning

1. Valves will reach high temperatures when used with high temperature fluids. Use caution, as there is a danger of being burned if the valve is directly touched.

### Caution

1. The valve of the pilot-operated 2-port solenoid valve may be opened momentarily and result in fluid leakage when pressure is applied to the valve suddenly (if the pump or compressor starts, for example) while the valve is closed. Please be cautious of this.
2. If a water hammer problem occurs, install either a water hammer attenuator (such as an accumulator) or use our water hammer resistant valve, the VXR series. For details, please contact us.





## EUROPEAN SUBSIDIARIES:



### Austria

SMC Pneumatik GmbH (Austria).  
Girakstrasse 8, A-2100 Korneuburg  
Phone: +43 2262-62280, Fax: +43 2262-62285  
E-mail: office@smc.at  
http://www.smc.at



### France

SMC Pneumatique, S.A.  
1, Boulevard de Strasbourg, Parc Gustave Eiffel  
Bussy Saint Georges F-77607 Marne La Vallée Cedex 3  
Phone: +33 (0)1-6476 1000, Fax: +33 (0)1-6476 1010  
E-mail: contact@smc-france.fr  
http://www.smc-france.fr



### Netherlands

SMC Pneumatics BV  
De Ruyterkade 120, NL-1011 AB Amsterdam  
Phone: +31 (0)20-5318888, Fax: +31 (0)20-5318880  
E-mail: info@smcpneumatics.nl  
http://www.smc-pneumatics.nl



### Spain

SMC España, S.A.  
Zuazobidea 14, 01015 Vitoria  
Phone: +34 945-184 100, Fax: +34 945-184 124  
E-mail: post@smc.smces.es  
http://www.smces.es



### Belgium

SMC Pneumatics N.V./S.A.  
Nijverheidsstraat 20, B-2160 Wommelgem  
Phone: +32 (0)3-355-1464, Fax: +32 (0)3-355-1466  
E-mail: post@smcpneumatics.be  
http://www.smc-pneumatics.be



### Germany

SMC Pneumatik GmbH  
Boschring 13-15, D-63329 Egelsbach  
Phone: +49 (0)6103-4020, Fax: +49 (0)6103-402139  
E-mail: info@smc-pneumatik.de  
http://www.smc-pneumatik.de



### Norway

SMC Pneumatics Norway A/S  
Vollsveien 13 C, Granfos Næringspark N-1366 Lysaker  
Tel: +47 67 12 90 20, Fax: +47 67 12 90 21  
E-mail: post@smc-norge.no  
http://www.smc-norge.no



### Sweden

SMC Pneumatics Sweden AB  
Ekhagsvägen 29-31, S-141 71 Huddinge  
Phone: +46 (0)8-603 12 00, Fax: +46 (0)8-603 12 90  
E-mail: post@smcpneumatics.se  
http://www.smc.nu



### Bulgaria

SMC Industrial Automation Bulgaria EOOD  
16 kiment Ohridski Blvd., fl.13 BG-1756 Sofia  
Phone: +359 2 9744492, Fax: +359 2 9744519  
E-mail: office@smc.bg  
http://www.smc.bg



### Greece

SMC Hellas EPE  
Anageniseos 7-9 - P.C. 14342, N. Philadelphia, Athens, Greece  
Phone: +30-210-2717265, Fax: +30-210-2717766  
E-mail: sales@smchellas.gr  
http://www.smchellas.gr



### Poland

SMC Industrial Automation Polska Sp.z.o.o.  
ul. Konstruktorska 11A, PL-02-673 Warszawa,  
Phone: +48 22 548 5085, Fax: +48 22 548 5087  
E-mail: office@smc.pl  
http://www.smc.pl



### Switzerland

SMC Pneumatik AG  
Dorfstrasse 7, CH-8484 Weisslingen  
Phone: +41 (0)52-396-3131, Fax: +41 (0)52-396-3191  
E-mail: info@smc.ch  
http://www.smc.ch



### Croatia

SMC Industrijska automatika d.o.o.  
Cromerec 12, 10000 ZAGREB  
Phone: +385 1 377 66 74, Fax: +385 1 377 66 74  
E-mail: office@smc.hr  
http://www.smc.hr



### Hungary

SMC Hungary Ipari Automatizálási Kft.  
Budafoki út 107-113, H-1117 Budapest  
Phone: +36 1 371 1343, Fax: +36 1 371 1344  
E-mail: office@smc.hu  
http://www.smc.hu



### Portugal

SMC Sucursal Portugal, S.A.  
Rua de Engº Ferreira Dias 452, 4100-246 Porto  
Phone: +351 22-610-89-22, Fax: +351 22-610-89-36  
E-mail: postpt@smc.smces.es  
http://www.smces.es



### Turkey

Entek Pnömatik San. ve Tic Ltd. Sti.  
Perpa Tic. Merkezi Kat: 11 No: 1625, TR-80270 Okmeydanı Istanbul  
Phone: +90 (0)212-221-1512, Fax: +90 (0)212-221-1519  
E-mail: smc-entek@entek.com.tr  
http://www.entek.com.tr



### Czech Republic

SMC Industrial Automation CZ s.r.o.  
Hudcova 78a, CZ-61200 Brno  
Phone: +420 5 414 24611, Fax: +420 5 412 18034  
E-mail: office@smc.cz  
http://www.smc.cz



### Ireland

SMC Pneumatics (Ireland) Ltd.  
2002 Citywest Business Campus, Naas Road, Saggart, Co. Dublin  
Phone: +353 (0)1-403 9000, Fax: +353 (0)1-464-0500  
E-mail: sales@smcpneumatics.ie  
http://www.smc-pneumatics.ie



### Romania

SMC Romania srl  
Str Frunzei 29, Sector 2, Bucharest  
Phone: +40 213205111, Fax: +40 213261489  
E-mail: smcromania@smcromania.ro  
http://www.smcromania.ro



### UK

SMC Pneumatics (UK) Ltd  
Vincent Avenue, Crownhill, Milton Keynes, MK8 0AN  
Phone: +44 (0)800 1382930 Fax: +44 (0)1908-555064  
E-mail: sales@smcpneumatics.co.uk  
http://www.smc-pneumatics.co.uk



### Denmark

SMC Pneumatik A/S  
Knudsminde 4B, DK-8300 Odder  
Phone: +45 70252900, Fax: +45 70252901  
E-mail: smc@smc-pneumatik.dk  
http://www.smc-dk.com



### Italy

SMC Italia S.p.A  
Via Garibaldi 62, I-20061 Carugate, (Milano)  
Phone: +39 (0)2-92711, Fax: +39 (0)2-9271365  
E-mail: mailbox@smcitalia.it  
http://www.smcitalia.it



### Russia

SMC Pneumatik LLC.  
4B Sverdlovskaja nab, St. Petersburg 195009  
Phone: +812 718 5445, Fax: +812 718 5449  
E-mail: info@smc-pneumatik.ru  
http://www.smc-pneumatik.ru



### Estonia

SMC Pneumatics Estonia OÜ  
Laki 12-101, 106 21 Tallinn  
Phone: +372 (0)6 593540, Fax: +372 (0)6 593541  
E-mail: smc@smcpneumatics.ee  
http://www.smc-pneumatics.ee



### Latvia

SMC Pneumatics Latvia SIA  
Smerla 1-705, Riga LV-1006, Latvia  
Phone: +371 781-77-00, Fax: +371 781-77-01  
E-mail: info@smclv.lv  
http://www.smclv.lv



### Slovakia

SMC Priemyselná Automatizácia, s.r.o.  
Námestie Martina Benku 10, SK-81107 Bratislava  
Phone: +421 2 444 56725, Fax: +421 2 444 56028  
E-mail: office@smc.sk  
http://www.smc.sk



### Finland

SMC Pneumatics Finland OY  
PL72, Tiistiniityntie 4, SF-02031 ESPOO  
Phone: +358 207 513513, Fax: +358 207 513595  
E-mail: smcfi@smc.fi  
http://www.smc.fi



### Lithuania

SMC Pneumatics Lietuva, UAB  
Savanoriu pr. 180, LT-01354 Vilnius, Lithuania  
Phone: +370 5 264 81 26, Fax: +370 5 264 81 26



### Slovenia

SMC industrijska Avtomatika d.o.o.  
Grajski trg 15, SLO-8360 Zuzemberk  
Phone: +386 738 85240 Fax: +386 738 85249  
E-mail: office@smc.si  
http://www.smc.si



## OTHER SUBSIDIARIES WORLDWIDE:

ARGENTINA, AUSTRALIA, BOLIVIA, BRASIL, CANADA, CHILE,  
CHINA, HONG KONG, INDIA, INDONESIA, MALAYSIA, MEXICO,  
NEW ZEALAND, PHILIPPINES, SINGAPORE, SOUTH KOREA,  
TAIWAN, THAILAND, USA, VENEZUELA

<http://www.smceu.com>  
<http://www.smcworld.com>