

Model No.	POS.1	POS.2	POS.3
2MS3	ON	OFF	ON
Term. Comm.	2-3	OPEN	2-1
SCHEMATIC			

SWITCH FUNCTION

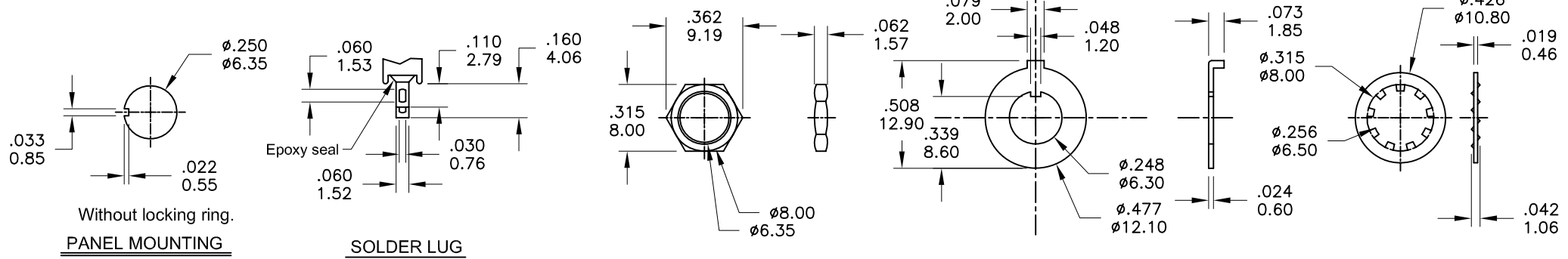

**SPECIFICATIONS**

**MECHANICAL LIFE:** 30,000 make-and-break cycles.  
**CONTACT RESISTANCE:** 20mΩ max. initial @ 2-4VDC  
 100mA for both silver and gold plated contacts.  
**INSULATION RESISTANCE:** 1,000MΩ min.  
**DIELECTRIC STRENGTH:** 1,000 V RMS@sea level.  
**OPERATING TEMPERATURE:** -30°C to 85°C.

**MATERIALS**

**CASE** - Diallyl phthalate(DAP)( UL94V-0 )  
**ACTUATOR** - Brass,chrome plated  
**BUSHING** - Brass,nickel plated  
**HOUSING** - Stainless Steel  
**SWITCH SUPPORT** - Brass,tin plated.  
**TERMINALS/CONTACT** - Brass, with Silver or gold plated.  
**ROHS** - 2002/95/EC

**RATING :**

R : 0.4 Volt-Amps(VA) max. @20V max.(AC or DC)  
 Q : 1Amp @250VAC  
 3Amps @120 VAC or 28 VDC

RS Article #394443

TITLE 圖名	Sub - Miniature Toggle Switches		SIZE 圖紙	A4
DWG NO. 圖號	2MS3TL1B25M1QES-1		UNIT 單位	inch mm
REV. 版本	A	DATE 日期	MAY - 15 - 2007	SHEET 張數
CHECKED BY 審核	RICHARD		DRAWN BY 製圖	FION

符號	原尺寸	修改後尺寸	變更日期	SCALE (比例): 3:2
1 (A)				TOLERANCE (公差): 0.00 mm ± 0.25mm 0.0 mm ± 0.40mm ANGULAR : ± 5° FILE NAME : 2MSP0412
2 (B)				
3 (C)				
4 (D)				
5 (E)				