

PRODUCT DATA AND INSTALLATION SHEET

279-8620 ELECTRONIC TIME LAG SWITCH

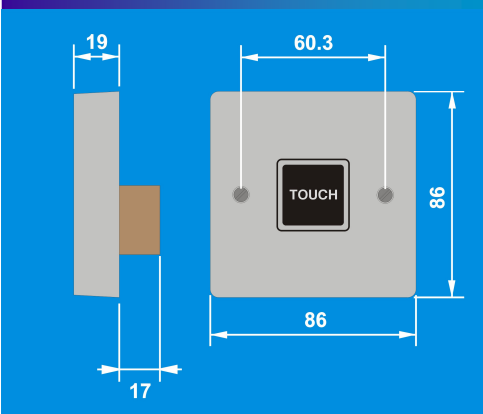

DESCRIPTION AND OPERATION

The 279-8620 time lag switch is a quick and effective way to reduce energy consumption for lighting applications. Pressing the touch pad brings the lights on; the lights will then switch off automatically after a preset time period has elapsed.

These units do not require a neutral connection, therefore they can be used to replace an existing light switch. The duration of the time delay is set by a thumbwheel on the reverse of the unit.

Time lag switches can be used in two way and intermediate switching arrangements without any extra wiring.

WIRING

Conventional Wiring

Wire the units as in diagram 1. When using multiple switch positions see diagram 2.

For two way and intermediate switching follow the diagrams overleaf. Note that as long as each switch position has a *Live* feed and a *Live Out* connection to the load then the switch will be properly wired.

INSTALLATION

Warning. This device works at mains potential. Be sure to take care when working with electricity.

1. Make sure the load is connected and in working order.
2. Isolate the mains supply to the circuit at the main consumer unit.
3. Connect the controller via the terminal block. Live supply to the *L* terminal and the load to the *LIVE OUT* terminal.
4. Set the timing range using the thumbwheel. Turn clockwise to increase timing.
5. Screw the unit to the wall and switch the mains supply back on at the distribution board.
6. **Wait 20 seconds before pushing the touch pad**
7. Press the touch pad and the lights will come on
8. Wait for the time period and the lights will turn off again.

Diagram 1
Conventional
wiring

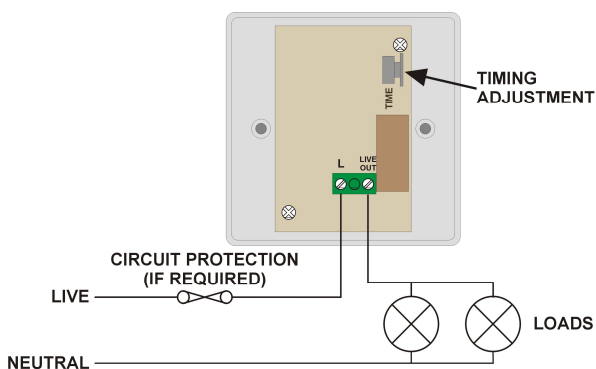
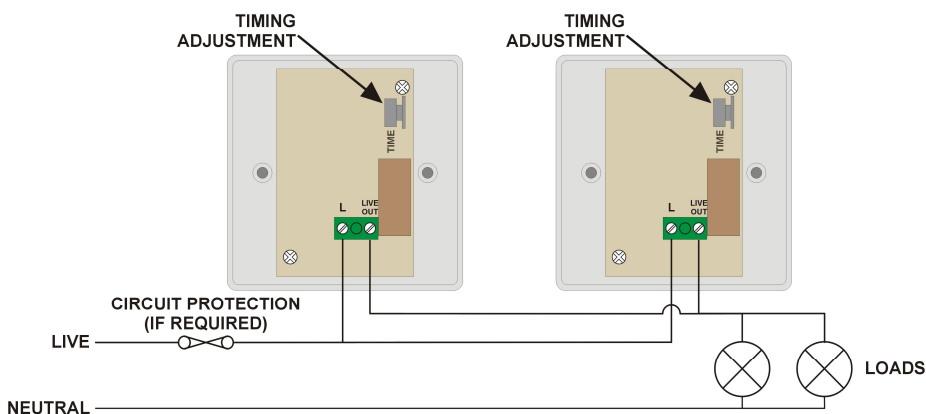

Diagram 2
Multiple switch
locations



FAULT FINDING

LIGHTS DO NOT COME ON

Check to see if the live supply to the circuit is good. Strap across the *L* and *LIVE OUT* terminal to turn the load on.

LIGHTS DO NOT GO OFF

Ensure that you have waited for the time out period.

If the lights still do not go off then it is likely the unit was not given the 20 seconds start up period on installation. Follow this procedure:

1. Isolate the mains supply to the circuit at the main consumer unit and unscrew the unit from the wall.
2. Turn the lights off by tapping the relay on the rear of the unit with the handle of a screwdriver until the contact opens.
3. Reapply the mains and wait for 20 seconds.
4. Activate timer as normal.

LIGHTS FLICKER

Ensure that there are sufficient power factor correction capacitors fitted.

SPECIFICATION

LOAD

10 Amp incandescent lighting
 5 Amp fluorescent lighting
 3 Amp compact fluorescent lighting
 3 Amp low energy lighting
 3 Amp low voltage lighting (switch primary of transformer)
 Fluorescent lighting (max 6 fittings recommended)
 Most fluorescent fittings have power factor correction capacitors fitted. If they are not present the unit may fail to turn off properly or flicker. In this case fit one capacitor per circuit with a minimum value of 1µF for every unit installed. The capacitor should be fitted across switched live and neutral. Note that it is not necessary to fit a capacitor on every fitting. This also applies to fittings controlled with high frequency ballasts and maintained emergency fittings.

For fluorescent lighting total power factor correction capacitance must not exceed 40µF.

Not suitable for switching contactors

Not suitable for SON lighting

Not suitable for heating or ventilation loads.

Please contact our sales department for a suitable alternative product.

SUPPLY VOLTAGE 220-240 Volts AC 50 Hz

TIME OUT PERIOD 20 seconds to 20 minutes (approximate)

FIXING METHOD Surface fixing 25mm deep plastic surface mount moulded box.

Flush fixing 25mm steel wall box or 32mm deep cavity wall box.

TERMINAL CAPACITY 1.5mm²

MATERIAL Flame retardant ABS

TYPE Class 2

TEMPERATURE -10°C to 35°C

CONFORMITY EMC-89/336/EEC
 LVD-73/23/EEC 

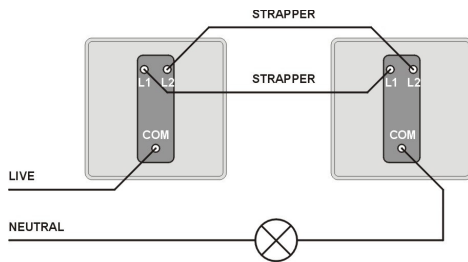

WIRING DIAGRAM FOR TWO WAY SWITCHING

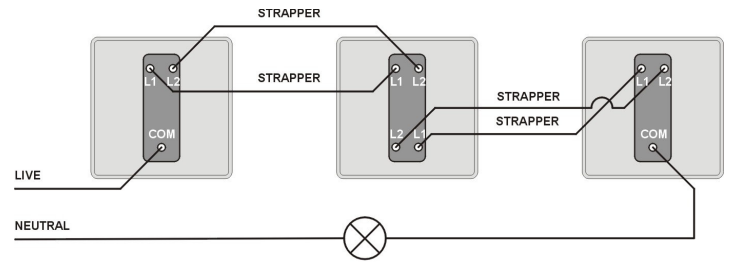

WIRING DIAGRAM FOR TWO WAY AND INTERMEDIATE SWITCHING

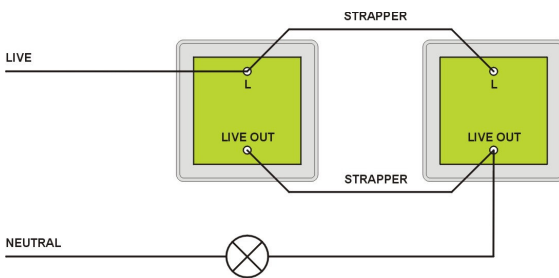

WIRING DIAGRAM FOR TWO WAY SWITCHING USING TIME LAG SWITCHES

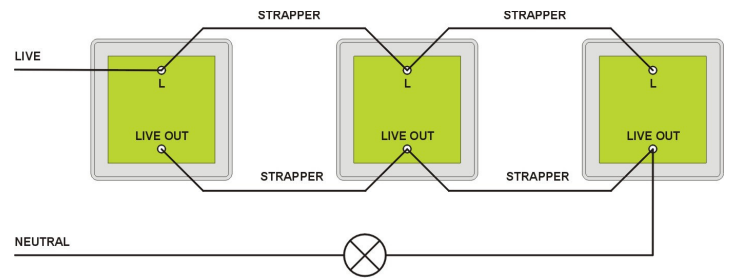

WIRING DIAGRAM FOR INTERMEDIATE AND TWO WAY SWITCHING USING TIME LAG SWITCHES

PART NUMBERS

279-8620 Electronic time lag switch touch activated

IMPORTANT NOTICE!

This device should be installed by a qualified electrician in accordance with the latest edition of the IEE wiring regulations.

Due to our policy of continual product improvement CP Electronics reserves the right to alter the specification of this product without prior notice.