



Mechanically Jointed Rodless Cylinder Series MY1



High Accuracy



Allowable moment Large

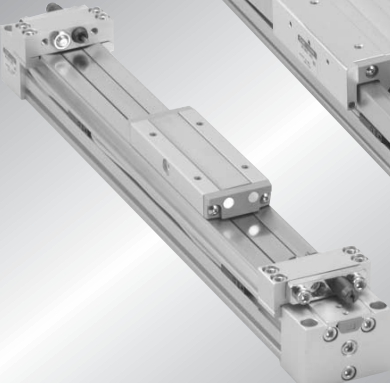

Basic type
Series MY1B

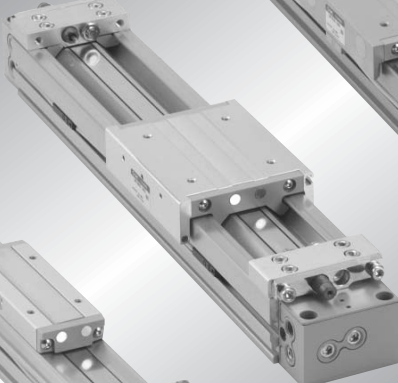

Slide bearing guide type
Series MY1M

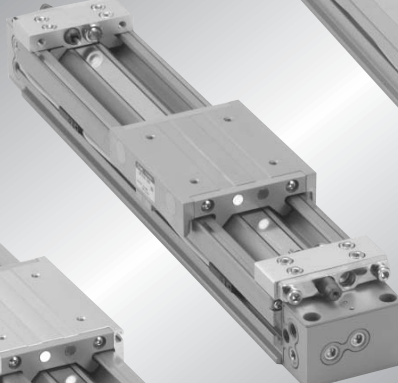

Cam follower guide type
Series MY1C

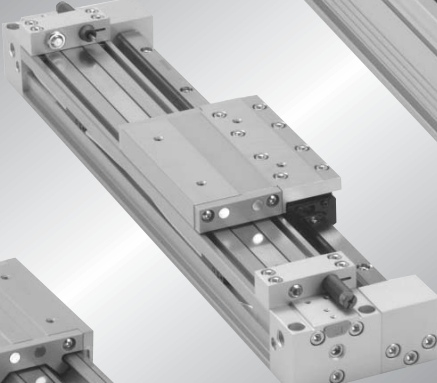

High precision guide type
Series MY1H

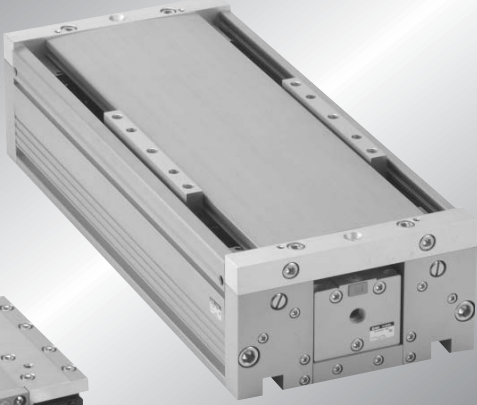

High rigidity/High precision guide type
Series MY1HT

- MX
- MTS
- MY
- CY
- MG
- CX
- D-
- X
- 20-
- Data

Five types of guide allow a wide range of selections.

Series Variations			Bore size (mm)								Air cushion	Stroke adjusting Unit	Side support	Floating bracket	End rod	Made to Order ⁽³⁾		
Series	Guide type	Piping type ⁽¹⁾	10	16	20	25	32	40	50	63							80	100
MY1B	Basic type	Centralized piping Standard piping														Intermediate stroke Long stroke Helical insert thread Dust seal band NBR lining Holder mounting bracket	P.8-11-11	
MY1M	Slide bearing guide type																	P.8-11-35
MY1C	Cam follower guide type																	P.8-11-51
MY1H	High precision guide type																	P.8-11-67
MY1HT	High rigidity/High precision guide type																	P.8-11-89

Note 1) $\phi 10$ is available with central piping only. Note 2) $\phi 10$ is available with rubber bumper only.
 Note 3) Availability for made-to-order differs, depending on the size and the model.

Mechanically Jointed Rodless Cylinder

MY1 Series

Basic type

Series MY1B

Can be combined with a variety of guides to accommodate conditions. Simple design without guide facilitates space savings.

Basic type



Wide variations from $\phi 10$ to $\phi 100$

Slide bearing type

Series MY1M

Integral guide allows use in a wide range of conveyor systems.

Moderate type

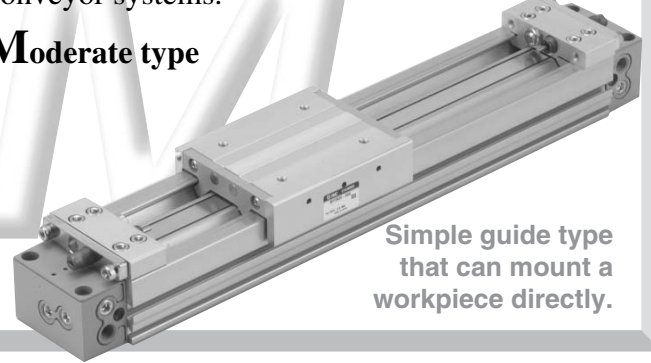

Simple guide type that can mount a workpiece directly.

Cam follower guide type

Series MY1C

Makes smooth operation possible even with an off-set load.

Cam follower type

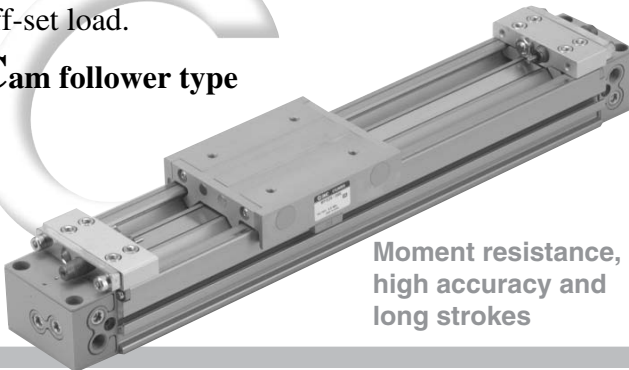

Moment resistance, high accuracy and long strokes

High precision guide type

Series MY1H

Small and medium sizes $\phi 10$ to $\phi 40$ are ideal for pick & place.

High precision type

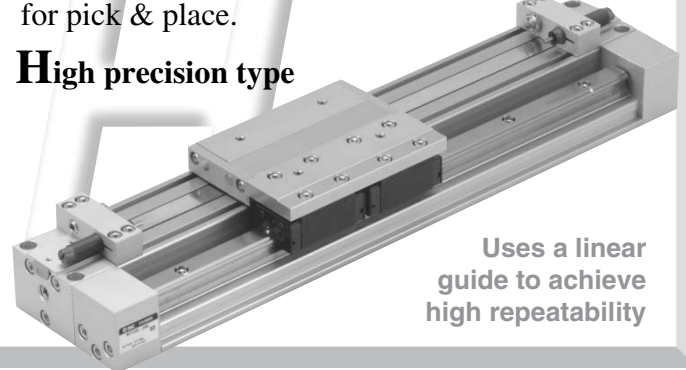

Uses a linear guide to achieve high repeatability

High rigidity/High precision guide type

Series MY1HT

High load, high moment and high precision. Ideal for transfer and pick & place of high load workpieces.

High precision Twin guide type



Linear guide. Higher load workpieces can be accommodated by using two linear guides.

Stroke availability

Strokes may be selected in increments of 1 mm.

Stroke adjusting unit

Strokes can be adjusted either at one side or both sides.

- Adjusting bolt
- Low load shock absorber + Adjusting bolt (L unit)
- High load shock absorber + Adjusting bolt (H unit)

Centralized piping

Piping ports are concentrated at one side.

Side support

Side support prevents a cylinder tube from sagging in long stroke applications.

Interchangeability

The bodies and workpiece mountings are interchangeable between Series MY1M and MY1C.

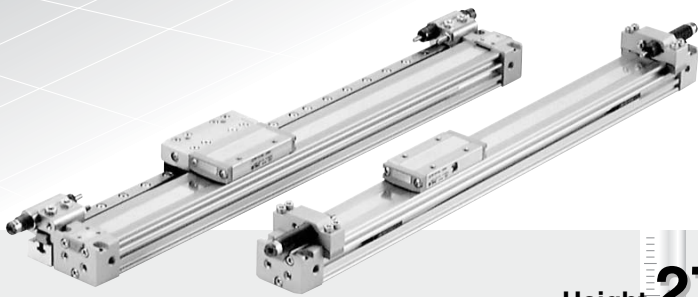

Basic type MY1B10

Height **27 mm**

High precision guide type MY1H10



- Even when equipped with a floating bracket, the height is only 28.5 mm.

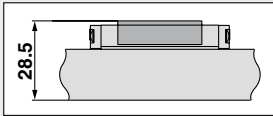

- The stroke adjusting unit (H unit) does not protrude above the table type.

- Stroke adjusting unit can be mounted
- Centralized piping type (Standard)

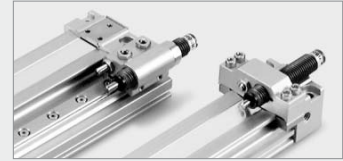

MX

MTS

MY

CY

MG

CX

D-

-X

20-

Data



Uses two linear guides.
Maximum load weight of 320 kg. (ø63)

High rigidity/High precision guide type MY1HT50/63

Extremely easy to maintain

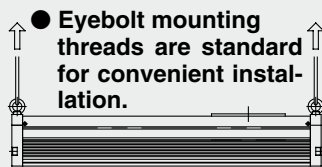

- Eyebolt mounting threads are standard for convenient installation.

Using eyebolts

- It is possible to replace cylinders with a workpiece being mounted.

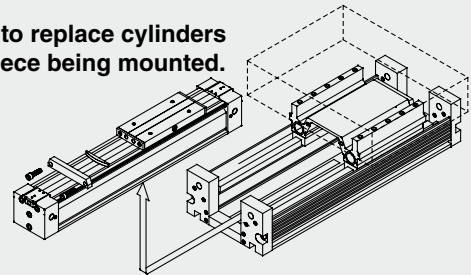

End lock type introduced to series MY1H.

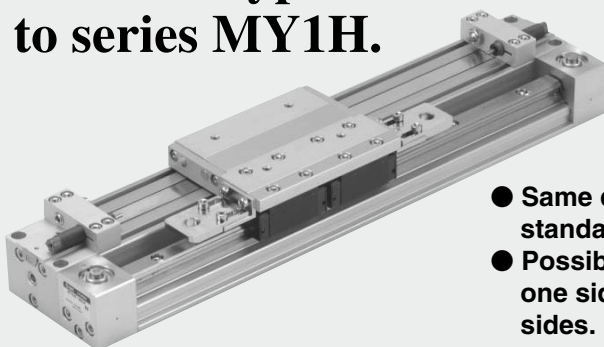

- Same dimensions as standard
- Possible to lock either on one side or on both sides.

Lock pin

Allows fine stroke control

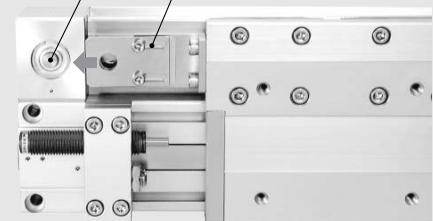

Model Selection

Following are the steps for selecting the most suitable Series MY1 to your application.

Standards for Tentative Model Selection

Cylinder model	Guide type	Standards for guide selection	Graphs for related allowable values
MY1B	Basic type	Guaranteed accuracy not required, generally combined with separate guide	Refer to P. 8-11-12.
MY1M	Slide bearing guide type	Slide table accuracy approx. ± 0.12 mm ⁽²⁾	Refer to P. 8-11-36.
MY1C	Cam follower guide type	Slide table accuracy approx. ± 0.05 mm ⁽²⁾	Refer to P. 8-11-52.
MY1H	High precision guide type	Slide table accuracy of ± 0.05 mm or less required ⁽²⁾	Refer to P. 8-11-68.
MY1HT	High rigidity/High precision guide type	Slide table accuracy of ± 0.05 mm or less required ⁽²⁾	Refer to P. 8-11-90.

Note 1) These accuracy values for each guide should be used only as a guide during selection. Please contact SMC when guaranteed accuracy for MY1C/MY1H is required.

Note 2) "Accuracy" here means displacement of the slide table (at stroke end) when 50% of the allowable moment shown in the catalog is applied. (reference value).

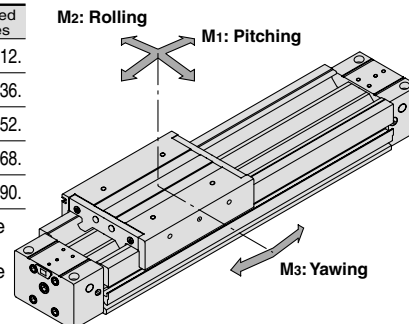

Selection Flow Chart

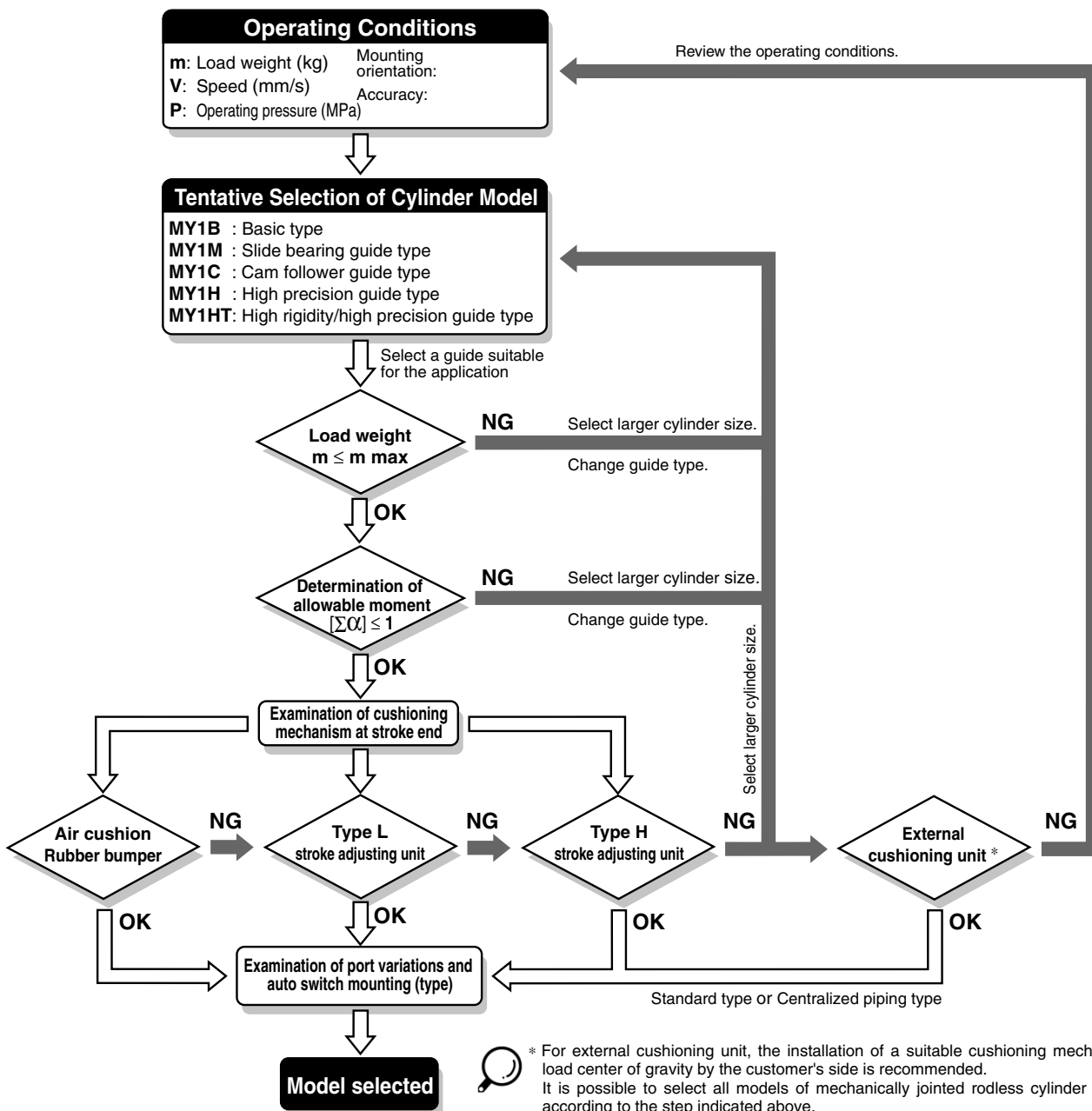

* For external cushioning unit, the installation of a suitable cushioning mechanism near the load center of gravity by the customer's side is recommended. It is possible to select all models of mechanically jointed rodless cylinder (Series MY1□) according to the step indicated above. Refer to the separate instruction manual for further details. If you have any questions, please contact SMC.

Types of Moment Applied to Rodless Cylinders

Multiple moments may be generated depending on the mounting orientation, load, and position of the center of gravity.

Coordinates and Moments

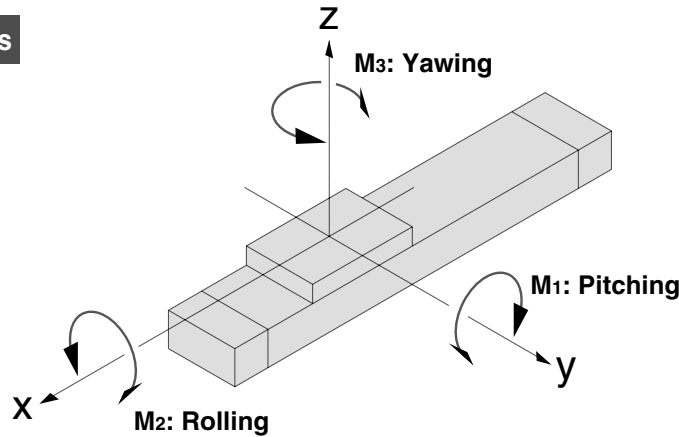

Static Moment

Horizontal mounting

Ceiling mounting

Wall mounting

Vertical mounting

g: Gravitational acceleration

Mounting orientation	Horizontal mounting	Ceiling mounting	Wall mounting	Vertical mounting
Static load (m)	m₁	m₂	m₃	m₄ (Note)
Static moment	M₁	M₂	M₃	M₄
	$m_1 \times g \times X$	$m_2 \times g \times X$	$m_3 \times g \times Z$	$m_4 \times g \times Z$
	$m_1 \times g \times Y$	$m_2 \times g \times Y$	$m_3 \times g \times X$	—
	—	—	$m_3 \times g \times X$	$m_4 \times g \times Y$

Note) m₄ is a mass movable by thrust. Use 0.3 to 0.7 times the thrust (differs depending on the operating speed) as a guide for actual use.

Dynamic Moment

Mounting orientation	Horizontal mounting	Ceiling mounting	Wall mounting	Vertical mounting
Dynamic load F_E	$1.4 \nu a \times \delta \times m_n \times g$			
Adjusting bolt	M1E	$\frac{1}{3} \times F_E \times Z$		
	M2E	Dynamic moment M_{2E} is not generated.		
	M3E	$\frac{1}{3} \times F_E \times Y$		

Note) Regardless of the mounting orientation, dynamic moment is calculated with the formulae above.

g: Gravitational acceleration, νa : Average speed, δ : Damper coefficient

- MX
- MTS
- MY
- CY
- MG
- CX
- D-
- X
- 20-
- Data

Model Selection

Following are the steps for selecting the most suitable Series MY1 to your application.

Calculation of Guide Load Factor

1. Operating Conditions

Operating cylinder MY1H40-500
 Average operating speed v_a ... 300 mm/s
 Mounting orientation Wall mounting
 Cushion Air cushion
 ($\delta = 1/100$)

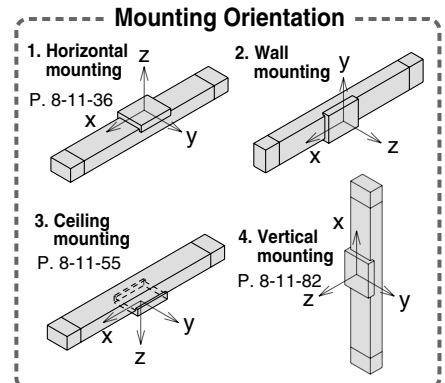
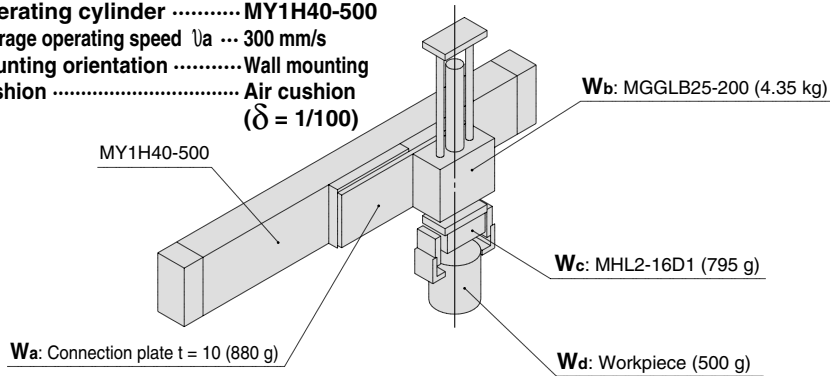

For actual examples of calculation for each orientation, refer to the pages above.

2. Load Blocking

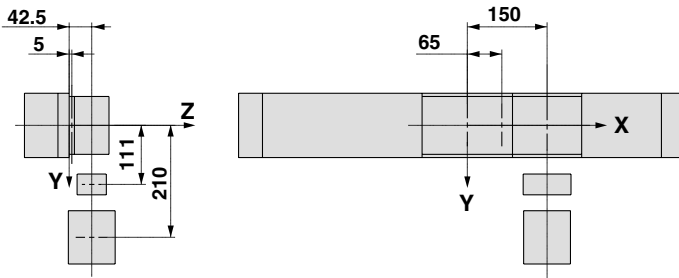

Weight and Center of Gravity for Each Workpiece

Workpiece no. W_n	Weight m_n	Center of gravity		
		X-axis X_n	Y-axis Y_n	Z-axis Z_n
W_a	0.88 kg	65 mm	0 mm	5 mm
W_b	4.35 kg	150 mm	0 mm	42.5 mm
W_c	0.795 kg	150 mm	111 mm	42.5 mm
W_d	0.5 kg	150 mm	210 mm	42.5 mm

$n = a, b, c, d$

3. Composite Center of Gravity Calculation

$$m_3 = \sum m_n$$

$$= 0.88 + 4.35 + 0.795 + 0.5 = \mathbf{6.525 \text{ kg}}$$

$$X = \frac{1}{m_3} \times \sum (m_n \times X_n)$$

$$= \frac{1}{6.525} (0.88 \times 65 + 4.35 \times 150 + 0.795 \times 150 + 0.5 \times 150) = \mathbf{138.5 \text{ mm}}$$

$$Y = \frac{1}{m_3} \times \sum (m_n \times Y_n)$$

$$= \frac{1}{6.525} (0.88 \times 0 + 4.35 \times 0 + 0.795 \times 111 + 0.5 \times 210) = \mathbf{29.6 \text{ mm}}$$

$$Z = \frac{1}{m_3} \times \sum (m_n \times Z_n)$$

$$= \frac{1}{6.525} (0.88 \times 5 + 4.35 \times 42.5 + 0.795 \times 42.5 + 0.5 \times 42.5) = \mathbf{37.4 \text{ mm}}$$

4. Calculation of Load Factor for Static Load

m₃: Weight
 $m_{3\max}$ (from (1) of graph MY1H/ m_3) = 50 (kg)
 Load factor $\alpha_1 = m_3/m_{3\max} = 6.525/50 = \mathbf{0.13}$

M₂: Moment
 $M_{2\max}$ (from (2) of graph MY1H/ M_2) = 50 (N·m)
 $M_2 = m_3 \times g \times X \times Z = 6.525 \times 9.8 \times 138.5 \times 37.4 \times 10^{-3} = \mathbf{2.39 \text{ (N·m)}}$
 Load factor $\alpha_2 = M_2/M_{2\max} = 2.39/50 = \mathbf{0.05}$

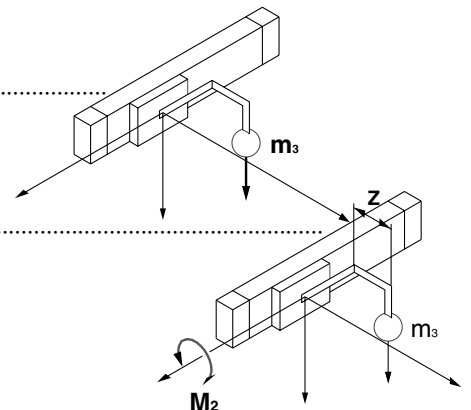

M₃: Moment

M_{3max} (from (3) of graph MY1H/M₃) = 38.7 (N·m)

$$M_3 = m_3 \times g \times X = 6.525 \times 9.8 \times 138.5 \times 10^{-3} = 8.86 \text{ (N·m)}$$

$$\text{Load factor } \alpha_3 = M_3/M_{3max} = 8.86/38.7 = \mathbf{0.23}$$

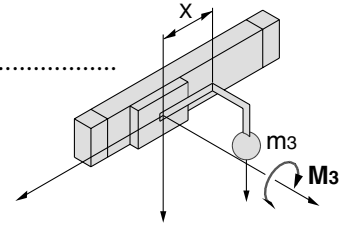

5. Calculation of Load Factor for Dynamic Moment

Equivalent load F_E at impact

$$F_E = 1.4 \nu a \times \delta \times m \times g = 1.4 \times 300 \times \frac{1}{100} \times 6.525 \times 9.8 = 268.6 \text{ (N)}$$

M_{1E}: Moment

M_{1Emax} (from (4) of graph MY1H/M₁ where $1.4 \nu a = 420 \text{ mm/s}$) = 35.9 (N·m)

$$M_{1E} = \frac{1}{3} \times F_E \times Z = \frac{1}{3} \times 268.6 \times 37.4 \times 10^{-3} = 3.35 \text{ (N·m)}$$

$$\text{Load factor } \alpha_4 = M_{1E}/M_{1Emax} = 3.35/35.9 = \mathbf{0.09}$$

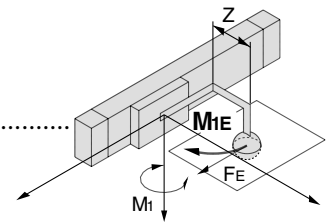

M_{3E}: Moment

M_{3Emax} (from (5) of graph MY1H/M₃ where $1.4 \nu a = 420 \text{ mm/s}$) = 27.6 (N·m)

$$M_{3E} = \frac{1}{3} \times F_E \times Y = \frac{1}{3} \times 268.6 \times 29.6 \times 10^{-3} = 2.65 \text{ (N·m)}$$

$$\text{Load factor } \alpha_5 = M_{3E}/M_{3Emax} = 2.65/27.6 = \mathbf{0.10}$$

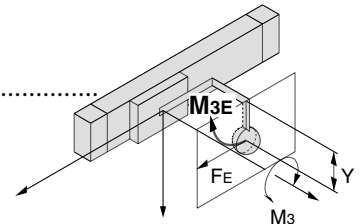

6. Sum and Examination of Guide Load Factors

$$\Sigma \alpha = \alpha_1 + \alpha_2 + \alpha_3 + \alpha_4 + \alpha_5 = \mathbf{0.60} \leq 1$$

The above calculation is within the allowable value, and therefore the selected model can be used.

Select a shock absorber separately.

In an actual calculation, when the sum of guide load factors $\Sigma \alpha$ in the formula above is more than 1, consider decreasing the speed, increasing the bore size, or changing the product series.

This calculation can be easily made using the "SMC Pneumatics CAD System".

Load Weight

MY1H/m₃

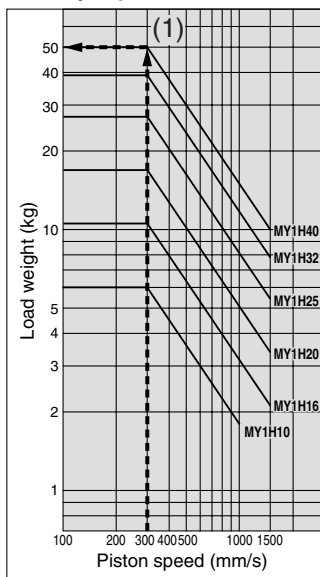

Allowable Moment

MY1H/M₁

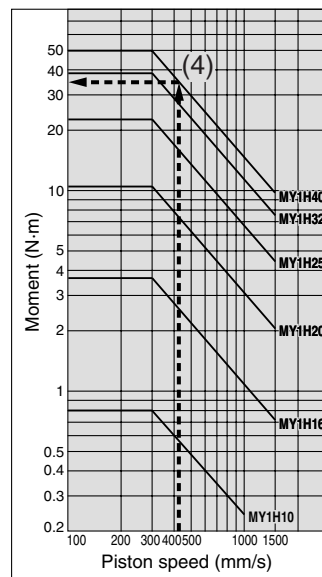

MY1H/M₂

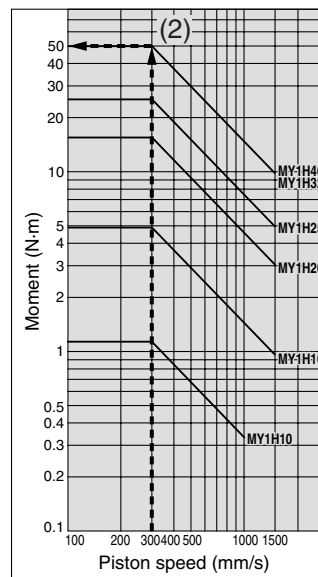

MY1H/M₃

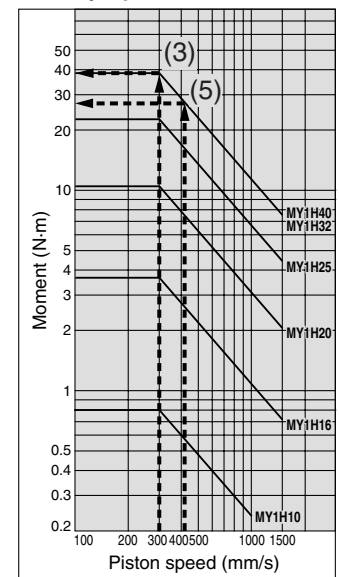

MX

MTS

MY

CY

MG

CX

D-

-X

20-

Data

⚠ Precautions

Be sure to read before handling. For Safety Instructions and Actuator Precautions, refer to pages 8-34-3 to 8-34-6.

Mounting

⚠ Caution

1. Do not apply strong impacts or excessive moment to the slide table (slider).

- The slide table (slider) is supported by precision bearings (MY1C, MY1H) or resin bearings (MY1B, MY1M). Therefore, do not apply strong impacts or excessive moment, etc., when mounting workpieces.

2. Align carefully when connecting to a load having an external guide mechanism.

- Mechanically jointed rodless cylinders can be used with a direct load within the allowable range for each type of guide. Please note that careful alignment is necessary when connecting to a load having an external guide mechanism. As the stroke becomes longer, variations in the center axis become larger. Consider using a connection method (floating mechanism) that is able to absorb these variations. Furthermore, use the special floating brackets (refer to page 8-11-28) which have been provided for Series MY1B.

3. Do not use in an environment where the cylinder is exposed to coolant, cutting oil, water drops, adhesive foreign particles, dust, etc. and avoid use with compressed air containing drainage and foreign particles.

- Foreign matter or liquids on the cylinder's interior or exterior can wash out the lubricating grease, which can lead to deterioration and damage of dust seal band and seal materials, causing a danger of malfunction.

When operating in locations with exposure to water and oil, or in dusty locations, provide protection such as a cover to prevent direct contact with the cylinder, or mount so that the dust seal band surface faces downward and operate with clean compressed air.

⚠ Caution

1. Do not unnecessarily alter the guide adjustment setting.

- The adjustment of the guide is preset and does not require readjustment under normal operating conditions. Therefore, do not unnecessarily alter the guide adjustment setting. However, series other than the MY1H Series can be readjusted and their bearings can be replaced.

To perform these operations, refer to the bearing replacement procedure given in the instruction manual.

⚠ Caution

1. Air leakage

- Take precautions under operating conditions in which negative pressure is increased inside the cylinder by external forces or inertial forces. Air leakage may occur due to separation of the seal belt.



Series MY1

Specific Product Precautions

Be sure to read before handling.

Centralized Piping Port Variations

Caution

• Head cover piping connection can be freely selected to best suit different piping conditions.

Applicable bore size	Port variations
<p>MY1B10 MY1H10</p>	<p>Note 1) These ports are not applicable to MY1H10.</p>
<p>MY1B16 to 100 MY1M16 to 63 MY1C16 to 63 MY1H16 to 40</p> <p>O-ring Piping tube</p>	<p>Note 2) For bottom piping, refer to the figure above.</p>
<p>MY1HT50/63</p>	

MX

MTS

MY

CY

MG

CX

D-

-X

20-

Data

Series MY1B

Basic Type

ø10, ø16, ø20, ø25, ø32, ø40, ø50, ø63, ø80, ø100

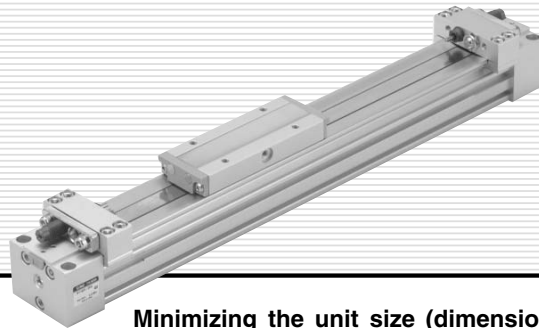

Minimizing the unit size (dimensions) and combination with other guides is possible.

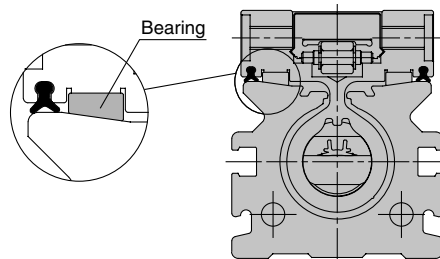

MX□

MTS

MY□

CY□

MG□

CX□

D-

-X

20-

Data

Series MY1B Before Operation

Maximum Allowable Moment/Maximum Load Weight

Model	Bore size (mm)	Maximum allowable moment (N·m)			Maximum load weight (kg)		
		M ₁	M ₂	M ₃	m ₁	m ₂	m ₃
MY1B	10	0.8	0.1	0.3	5.0	1.0	0.5
	16	2.5	0.3	0.8	15	3.0	1.7
	20	5.0	0.6	1.5	21	4.2	3.0
	25	10	1.2	3.0	29	5.8	5.4
	32	20	2.4	6.0	40	8.0	8.8
	40	40	4.8	12	53	10.6	14
	50	78	9.3	23	70	14	20
	63	160	19	48	83	16.6	29
	80	315	37	95	120	24	42
	100	615	73	18	150	30	60

The above values are the maximum allowable values for moment and load. Refer to each graph regarding the maximum allowable moment and maximum allowable load for a particular piston speed.

Caution on Design

We recommend installing an external shock absorber when the cylinder is combined with another guide (connection with floating bracket, etc.) and the maximum allowable load is exceeded, or when the operating speed is 1000 to 1500 mm/s for bore sizes ø16, ø50, ø63, ø80 and ø100.

Load weight (kg)

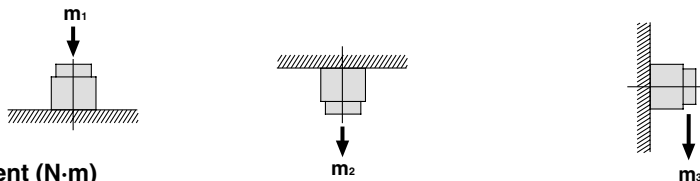

Moment (N·m)

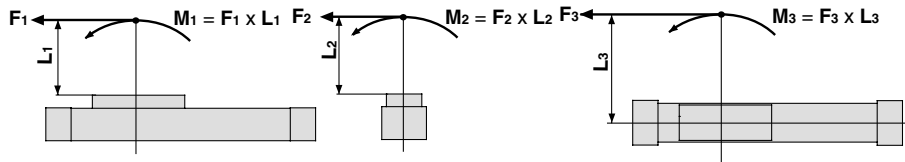

<Calculation of guide load factor>

- Maximum allowable load (1), static moment (2), and dynamic moment (3) (at the time of impact with stopper) must be examined for the selection calculations.
* To evaluate, use \bar{v}_a (average speed) for (1) and (2), and v (collision speed $v = 1.4 \bar{v}_a$) for (3). Calculate m_{max} for (1) from the maximum allowable load graph (m_1, m_2, m_3) and M_{max} for (2) and (3) from the maximum allowable moment graph (M_1, M_2, M_3).

$$\text{Sum of guide load factors } \Sigma \alpha = \frac{\text{Load weight [m]}}{\text{Maximum allowable load [m}_{max}\text{]}} + \frac{\text{Static moment [M]}^{(1)}}{\text{Allowable static moment [M}_{max}\text{]}} + \frac{\text{Dynamic moment [M}_E\text{]}^{(2)}}{\text{Allowable dynamic moment [M}_{E,max}\text{]}} \leq 1$$

Note 1) Moment caused by the load, etc., with cylinder in resting condition.

Note 2) Moment caused by the impact load equivalent at the stroke end (at the time of impact with stopper).

Note 3) Depending on the shape of the workpiece, multiple moments may occur. When this happens, the sum of the load factors ($\Sigma \alpha$) is the total of all such moments.

2. Reference formula [Dynamic moment at impact]

Use the following formulae to calculate dynamic moment when taking stopper impact into consideration.

m: Load weight (kg)

F: Load (N)

F_E: Load equivalent to impact (at impact with stopper) (N)

\bar{v}_a : Average speed (mm/s)

M: Static moment (N·m)

$v = 1.4 \bar{v}_a$ (mm/s) $F_E = 1.4 \bar{v}_a \cdot \delta \cdot m \cdot g$ ^{Note 4)}

$\therefore M_E = \frac{1}{3} \cdot F_E \cdot L_1 = 4.57 \bar{v}_a \delta m L$ ^{Note 5)}

v : Collision speed (mm/s)

L: Distance to the load's center of gravity (m)

M_E: Dynamic moment (N·m)

δ : Damper coefficient

With rubber bumper = 4/100

(MY1B10, MY1H10)

With air cushion = 1/100

With shock absorber = 1/100

g: Gravitational acceleration (9.8 m/s²)

Note 4) $1.4 \bar{v}_a \delta$ is a dimensionless coefficient for calculating impact force.

Note 5) Average load coefficient ($\frac{1}{3}$): This coefficient is for averaging the maximum load moment at the time of stopper impact according to service life calculations.

3. For detailed selection procedures, refer to pages 8-11-14 to 8-11-15.

Maximum Allowable Moment

Select the moment from within the range of operating limits shown in the graphs. Note that the maximum allowable load value may sometimes be exceeded even within the operating limits shown in the graphs. Therefore, also check the allowable load for the selected conditions.

Maximum Load Weight

Select the load from within the range of limits shown in the graphs. Note that the maximum allowable moment value may sometimes be exceeded even within the operating limits shown in the graphs. Therefore, also check the allowable moment for the selected conditions.

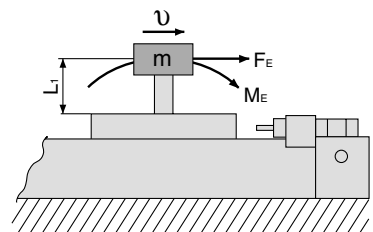

Mechanically Jointed Rodless Cylinder Basic Type Series MY1B

MY1B/M₁

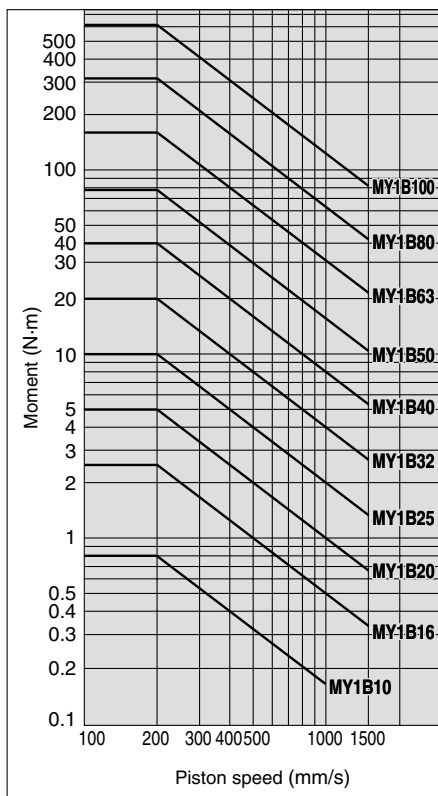

MY1B/M₂

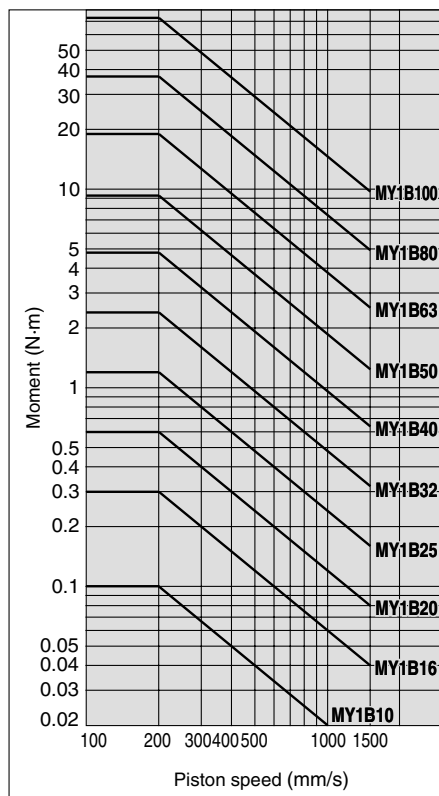

MY1B/M₃

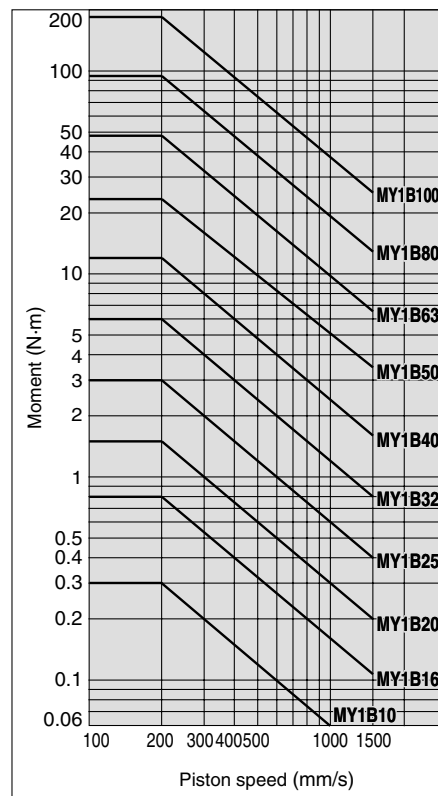

- MX
- MTS
- MY
- CY
- MG
- CX
- D-
- X
- 20-
- Data

MY1B/m₁

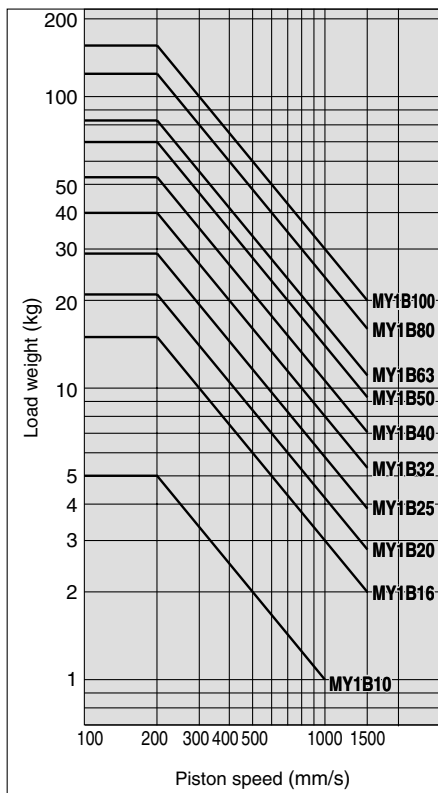

MY1B/m₂

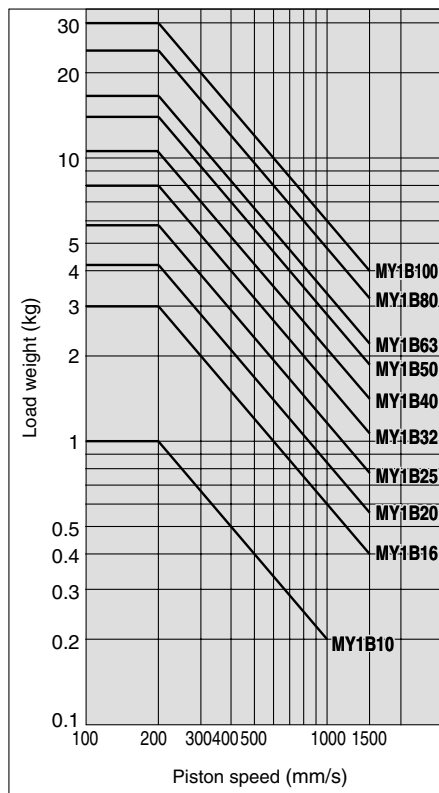

MY1B/m₃

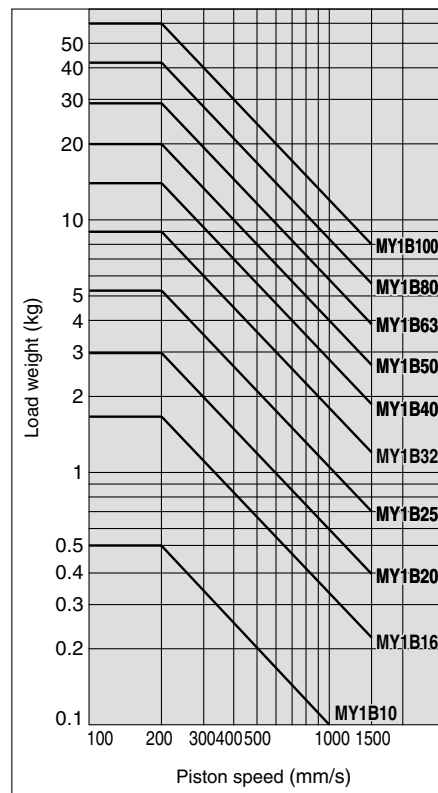

Model Selection

Following are the steps for selecting the most suitable Series MY1B to your application.

Calculation of Guide Load Factor

1. Operating Conditions

- Cylinder MY1B32-500
- Average operating speed v_a 300 mm/s
- Mounting orientation Horizontal mounting
- Cushion Air cushion
($\delta = 1/100$)

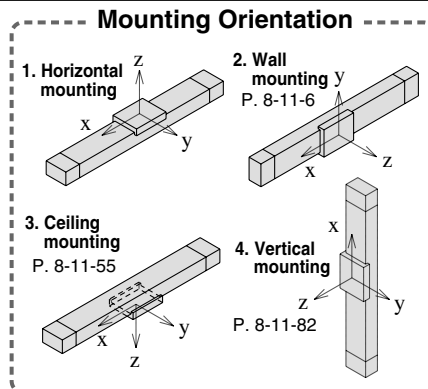
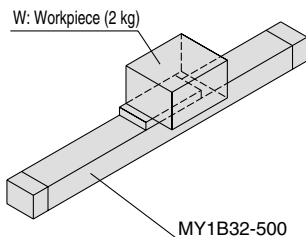

For actual examples of calculation for each orientation, refer to the pages above.

2. Load Blocking

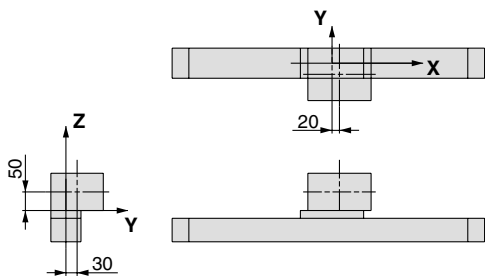

Weight and Center of Gravity for Workpiece

Workpiece no.	Weight m	Center of gravity		
		X-axis	Y-axis	Z-axis
W	2 kg	20 mm	30 mm	50 mm

3. Calculation of Load Factor for Static Load

m_1 : Weight

m_{1max} (from (1) of graph MY1B/ m_1) = 27 (kg).....

Load factor $\alpha_1 = m_1/m_{1max} = 2/27 = 0.07$

M_1 : Moment

M_{1max} (from (2) of graph MY1B/ M_1) = 13 (N·m).....

$M_1 = m_1 \times g \times X = 2 \times 9.8 \times 20 \times 10^{-3} = 0.39$ (N·m)

Load factor $\alpha_2 = M_1/M_{1max} = 0.39/13 = 0.03$

M_2 : Moment

M_{2max} (from (3) of graph MY1B/ M_2) = 1.6 (N·m).....

$M_2 = m_1 \times g \times Y = 2 \times 9.8 \times 30 \times 10^{-3} = 0.59$ (N·m)

Load factor $\alpha_3 = M_2/M_{2max} = 0.59/1.6 = 0.37$

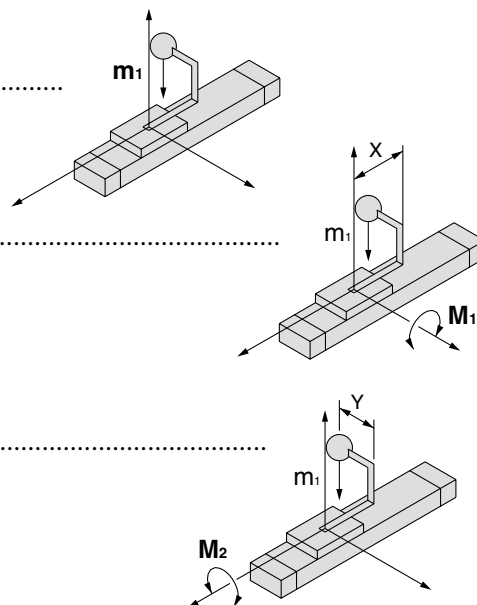

4. Calculation of Load Factor for Dynamic Moment

Equivalent load F_E at impact

$$F_E = 1.4 \nu a \times \delta \times m \times g = 1.4 \times 300 \times \frac{1}{100} \times 2 \times 9.8 = 82.3 \text{ (N)}$$

M_{1E} : Moment

$M_{1E\max}$ (from (4) of graph MY1B/ M_1 where $1.4 \nu a = 420 \text{ mm/s}$) = 9.5 (N·m).....

$$M_{1E} = \frac{1}{3} \times F_E \times Z = \frac{1}{3} \times 82.3 \times 50 \times 10^{-3} = 1.37 \text{ (N·m)}$$

$$\text{Load factor } \alpha_4 = M_{1E}/M_{1E\max} = 1.37/9.5 = 0.14$$

M_{3E} : Moment

$M_{3E\max}$ (from (5) of graph MY1B/ M_3 where $1.4 \nu a = 420 \text{ mm/s}$) = 2.9 (N·m).....

$$M_{3E} = \frac{1}{3} \times F_E \times Y = \frac{1}{3} \times 82.3 \times 30 \times 10^{-3} = 0.82 \text{ (N·m)}$$

$$\text{Load factor } \alpha_5 = M_{3E}/M_{3E\max} = 0.82/2.9 = 0.28$$

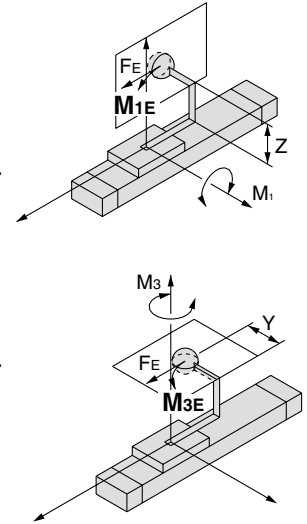

MX

MTS

MY

CY

MG

CX

D-

-X

20-

Data

5. Sum and Examination of Guide Load Factors

$$\Sigma \alpha = \alpha_1 + \alpha_2 + \alpha_3 + \alpha_4 + \alpha_5 = 0.89 \leq 1$$

The above calculation is within the allowable value, and therefore the selected model can be used.

Select a shock absorber separately.

In an actual calculation, when the total sum of guide load factors $\Sigma \alpha$ in the formula above is more than 1, consider either decreasing the speed, increasing the bore size, or changing the product series. This calculation can be easily made using the "SMC Pneumatics CAD System".

Load Weight

MY1B/ m_1

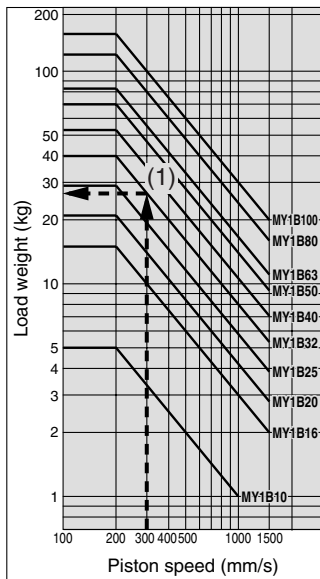

Allowable Moment

MY1B/ M_1

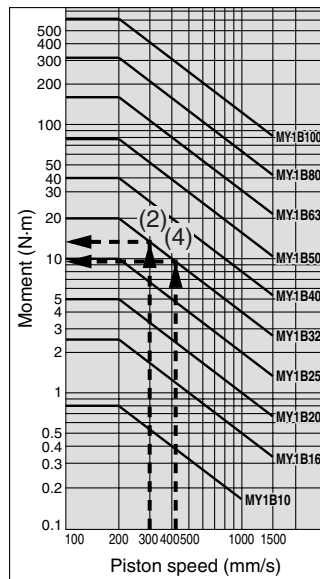

MY1B/ M_2

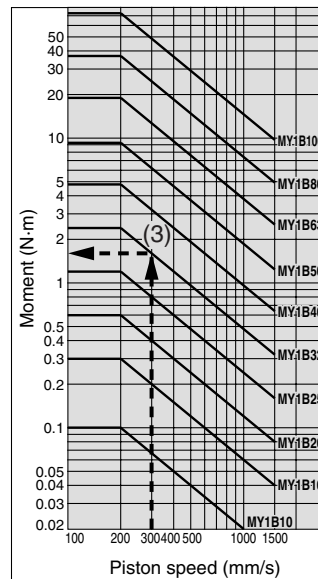

MY1B/ M_3

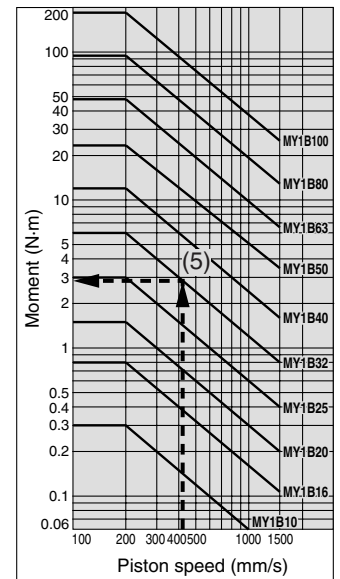



Mechanically Jointed Rodless Cylinder Basic Type

Series MY1B

ø10, ø16, ø20, ø25, ø32, ø40, ø50, ø63, ø80, ø100

How to Order

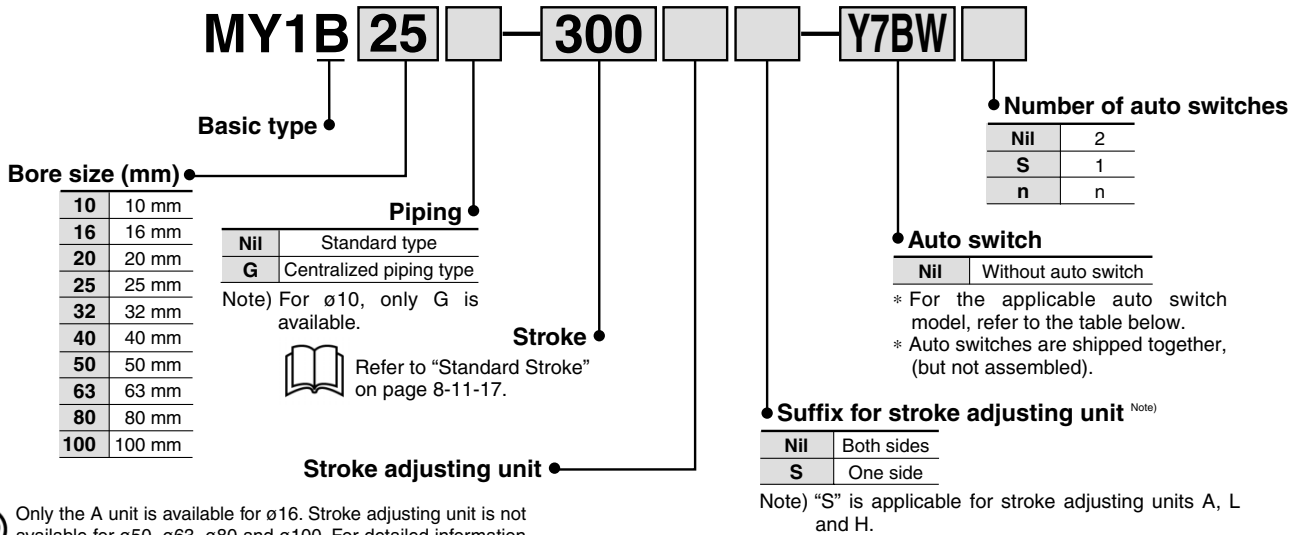

Only the A unit is available for ø16. Stroke adjusting unit is not available for ø50, ø63, ø80 and ø100. For detailed information on stroke adjusting unit specifications, refer to page 8-11-17.

Nil	Without adjusting unit
A	With adjusting bolt
L	With low load shock absorber + Adjusting bolt
H	With high load shock absorber + Adjusting bolt
AL	With one A unit and one L unit
AH	With one A unit and one H unit each
LH	With one L unit and one H unit each

Shock Absorbers for L and H Units

Bore size (mm)	10	20	25	32	40
L unit	—	RB0806	RB1007	RB1412	
H unit	RB0805	RB1007	RB1412	RB2015	

Applicable Auto Switch/Refer to page 8-30-1 for further information on auto switches. For ø10, ø16, ø20

Type	Special function	Electrical entry	Indicator light	Wiring (Output)	Load voltage			Auto switch model		Lead wire length (m)*			Pre-wire connector	Applicable load	
					DC	AC	Perpendicular	In-line	0.5 (Nil)	3 (L)	5 (Z)	IC circuit		Relay, PLC	
Reed switch	—	Grommet	Yes	3-wire (NPN equivalent)	—	5 V	—	A96V	A96	●	●	—	—	IC circuit	—
				2-wire	24 V	12 V	100 V	A93V	A93	●	●	—	—	—	Relay, PLC
Solid state switch	—	Grommet	Yes	3-wire (NPN)	24 V	5 V, 12 V	—	M9NV	M9N	●	●	○	○	IC circuit	Relay, PLC
				3-wire (PNP)				M9PV	M9P	●	●	○	○		
				2-wire				M9BV	M9B	●	●	○	○	—	
				3-wire (NPN)				F9NWV	F9NW	●	●	○	○	IC circuit	
				3-wire (PNP)				F9PWV	F9PW	●	●	○	○	—	
				2-wire				F9BWV	F9BW	●	●	○	○	—	

For ø25, ø32, ø40, ø50, ø63, ø80, ø100

Type	Special function	Electrical entry	Indicator light	Wiring (Output)	Load voltage			Auto switch model		Lead wire length (m)*			Pre-wire connector	Applicable load	
					DC	AC	Perpendicular	In-line	0.5 (Nil)	3 (L)	5 (Z)	IC circuit		Relay, PLC	
Reed switch	—	Grommet	Yes	3-wire (NPN equivalent)	—	5 V	—	—	Z76	●	●	—	—	IC circuit	—
				2-wire	24 V	12 V	100 V	—	Z73	●	●	—	—	—	Relay, PLC
Solid state switch	—	Grommet	Yes	3-wire (NPN)	24 V	5 V, 12 V	—	Y69A	Y59A	●	●	○	○	IC circuit	Relay, PLC
				3-wire (PNP)				Y7PV	Y7P	●	●	○	○		
				2-wire				Y69B	Y59B	●	●	○	○	—	
				3-wire (NPN)				Y7NWV	Y7NW	●	●	○	○	IC circuit	
				3-wire (PNP)				Y7PWV	Y7PW	●	●	○	○	—	
				2-wire				Y7BWV	Y7BW	●	●	○	○	—	

* Lead wire length symbols: 0.5 m.....Nil (Example) A93
3 m.....L (Example) Y59BL
5 m.....Z (Example) F9NWZ

* Solid state switches marked with "○" are produced upon receipt of order.

- There are other applicable auto switches than listed above. For details, refer to page 8-11-101.
- For details about auto switches with pre-wire connector, refer to page 8-30-52.

Mechanically Jointed Rodless Cylinder Basic Type Series MY1B

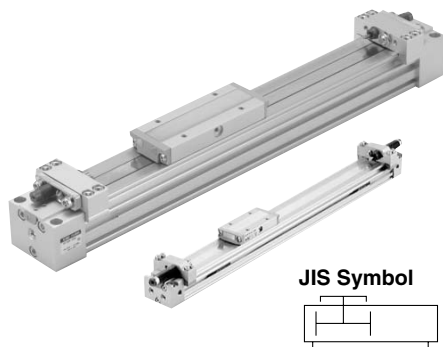

Specifications

Bore size (mm)	10	16	20	25	32	40	50	63	80	100	
Fluid	Air										
Action	Double acting										
Operating pressure range	0.2 to 0.8 MPa					0.1 to 0.8 MPa					
Proof pressure	1.2 MPa										
Ambient and fluid temperature	5 to 60°C										
Cushion	Rubber bumper					Air cushion					
Lubrication	Non-lube										
Stroke length tolerance	1000 or less $+1.8_0^{+2.8}$ 1001 to 3000 $+2.8_0^{+4.8}$					2700 or less $+1.8_0^{+2.8}$, 2701 to 5000 $+2.8_0^{+4.8}$					
Piping Port size	Front/Side port	M5 x 0.8			Rc 1/8		Rc 1/4	Rc 3/8		Rc 1/2	
	Bottom port	ø4			ø5	ø6	ø8	ø10	ø11	ø16	ø18

Stroke Adjusting Unit Specifications

Bore size (mm)	10			16			20			25			32			40		
Unit symbol	A	H	A	A	L	H	A	L	H	A	L	H	A	L	H			
Configuration	With adjusting bolt	RB 0805 with adjusting bolt	With adjusting bolt	With adjusting bolt	RB 0806 with adjusting bolt	RB 0807 with adjusting bolt	With adjusting bolt	RB 1007 with adjusting bolt	RB 1412 with adjusting bolt	With adjusting bolt	RB 1412 with adjusting bolt	RB 2015 with adjusting bolt	With adjusting bolt	RB 1412 with adjusting bolt	RB 2015 with adjusting bolt			
Fine stroke adjustment range (mm)	0 to -5		0 to -5.6		0 to -6			0 to -11.5			0 to -12			0 to -16				
Stroke adjustment range	When exceeding the stroke fine adjustment range: Utilize a made-to-order specifications "-X416" and "-X417".																	

Shock Absorber Specifications

Model	RB 0805	RB 0806	RB 1007	RB 1412	RB 2015	
Max. energy absorption (J)	1.0	2.9	5.9	19.6	58.8	
Stroke absorption (mm)	5	6	7	12	15	
Max. collision speed (mm/s)	1000	1500	1500	1500	1500	
Max. operating frequency(cycle/min)	80	80	70	45	25	
Spring force (N)	Extended	1.96	1.96	4.22	6.86	8.34
	Retracted	3.83	4.22	6.86	15.98	20.50
Operating temperature range (°C)	5 to 60					

Piston Speed

Bore size (mm)		10	16 to 100
Without stroke adjusting unit		100 to 500 mm/s	100 to 1000 mm/s
Stroke adjusting unit	A unit	100 to 200 mm/s	100 to 1000 mm/s ⁽¹⁾
	L unit and H unit	100 to 1000 mm/s	100 to 1500 mm/s ⁽²⁾

Note 1) Be aware that when the stroke adjusting range is increased by manipulating the adjusting bolt, the air cushion capacity decreases. Also, when exceeding the air cushion stroke ranges on page 8-11-20, the piston speed should be 100 to 200 mm per second.

Note 2) The piston speed is 100 to 1000 mm/s for centralized piping.

Note 3) Use at a speed within the absorption capacity range. Refer to page 8-11-19.



Made to Order Specifications (For details, refer to page 8-31-1.)

Symbol	Specifications
-XB11	Long stroke type
-XC18	NPT finish piping port
-XC67	NBR rubber lining in dust seal band
-X168	Helical insert thread specifications
-X416	Holder mounting bracket I
-X417	Holder mounting bracket II

Standard Stroke

Bore size (mm)	Standard stroke (mm)*	Maximum manufacturable stroke (mm)
10, 16	100, 200, 300, 400, 500, 600, 700	3000
20, 25, 32, 40, 50, 63, 80, 100	800, 900, 1000, 1200, 1400, 1600, 1800, 2000	5000

* Strokes are manufacturable in 1 mm increments, up to the maximum stroke. However, when exceeding a 2000 mm stroke, specify "-XB11" at the end of the model number.

MX

MTS

MY

CY

MG

CX

D-

-X

20-

Data

Series MY1B

Theoretical Output (N)

Bore size (mm)	Piston area (mm ²)	Operating pressure (MPa)							
		0.2	0.3	0.4	0.5	0.6	0.7	0.8	
10	78	15	23	31	39	46	54	62	
16	200	40	60	80	100	120	140	160	
20	314	62	94	125	157	188	219	251	
25	490	98	147	196	245	294	343	392	
32	804	161	241	322	402	483	563	643	
40	1256	251	377	502	628	754	879	1005	
50	1962	392	588	784	981	1177	1373	1569	
63	3115	623	934	1246	1557	1869	2180	2492	
80	5024	1004	1507	2009	2512	3014	3516	4019	
100	7850	1570	2355	3140	3925	4710	5495	6280	

Note) Theoretical output (N) = Pressure (MPa) x Piston area (mm²)

Weight (kg)

Bore size (mm)	Basic weight	Additional weight per each 50mm of stroke	Side support weight (per set)	Stroke adjusting unit weight (per unit)		
			Type A and B	A unit weight	L unit weight	H unit weight
10	0.15	0.04	0.003	0.01	—	0.02
16	0.61	0.06	0.01	0.04	—	—
20	1.06	0.10	0.02	0.05	0.05	0.10
25	1.33	0.12	0.02	0.06	0.10	0.18
32	2.65	0.18	0.02	0.12	0.21	0.40
40	3.87	0.27	0.04	0.23	0.32	0.49
50	7.78	0.44	0.04	—	—	—
63	13.10	0.70	0.08	—	—	—
80	20.70	1.18	0.17	—	—	—
100	35.70	1.97	0.17	—	—	—

Calculation: (Example) MY1B25-300A

- Basic weight 1.33 kg
- Cylinder stroke 300 stroke
- Additional weight 0.12/50 stroke
1.33 + 0.12 x 300/50 + 0.06 x 2 ≒ 2.17 kg
- Weight of A unit 0.06 kg

Option

Stroke Adjusting Unit Part No.

Bore size (mm)	10	16	20	25	32
A unit	MY-A10A	MY-A16A	MY-A20A	MY-A25A	MY-A32A
L unit	—	—	MY-A20L	MY-A25L	MY-A32L
H unit	MY-A10H	—	MY-A20H	MY-A25H	MY-A32H

Bore size (mm)	40
A unit	MY-A40A
L unit	MY-A40L
H unit	MY-A40H

Side Support Part No.

Bore size (mm)	10	16	20	25	32
Side support A	MY-S10A	MY-S16A	MY-S20A	MY-S25A	
Side support B	MY-S10B	MY-S16B	MY-S20B	MY-S25B	

Bore size (mm)	40	50	63	80	100
Side support A	MY-S32A		MY-S50A	MY-S63A	
Side support B	MY-S32B		MY-S50B	MY-S63B	

For details about dimensions, etc., refer to page 8-11-27.

Cushion Capacity

Cushion Selection

<Rubber bumper>

Rubber bumpers are a standard feature on MY1B10.

Since the stroke absorption of rubber bumpers is short, when adjusting the stroke with an A unit, install an external shock absorber.

The load and speed range which can be absorbed by a rubber bumper is inside the rubber bumper limit line of the graph.

<Air cushion>

Air cushions are a standard feature on mechanically jointed rodless cylinders. (Except $\phi 10$.)

The air cushion mechanism is incorporated to prevent excessive impact of the piston at the stroke end during high speed operation. The purpose of air cushion, thus, is not to decelerate the piston near the stroke end.

The ranges of load and speed that air cushions can absorb are within the air cushion limit lines shown in the graphs.

<Stroke adjusting unit with shock absorber>

Use this unit when operating with a load or speed exceeding the air cushion limit line, or when cushioning is required outside of the effective air cushion stroke range due to stroke adjustment.

L unit

Use this unit when cushioning is necessary outside of the effective air cushion range even if the load and speed are within the air cushion limit line, or when the cylinder is operated in a load and speed range above the air cushion limit line and below the L unit limit line.

H unit

Use this unit when the cylinder is operated in a load and speed range above the L unit limit line and below the H unit limit line.

⚠ Caution

1. Refer to the figure below when using the adjusting bolt to perform stroke adjustment.

When the effective stroke of the shock absorber decreases as a result of stroke adjustment, the absorption capacity decreases dramatically. Secure the adjusting bolt at the position where it protrudes approximately 0.5 mm from the shock absorber.

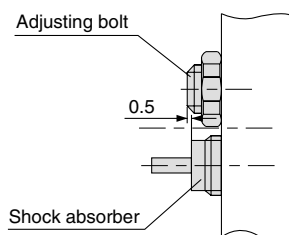

2. Do not use a shock absorber together with air cushion.

Absorption Capacity of Rubber Bumper, Air Cushion and Stroke Adjusting Units

MY1B10 Horizontal collision: P = 0.5 MPa

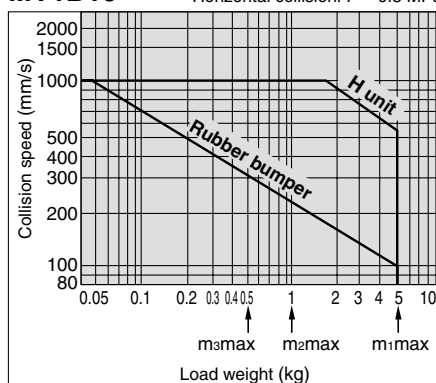

MY1B32 Horizontal collision: P = 0.5 MPa

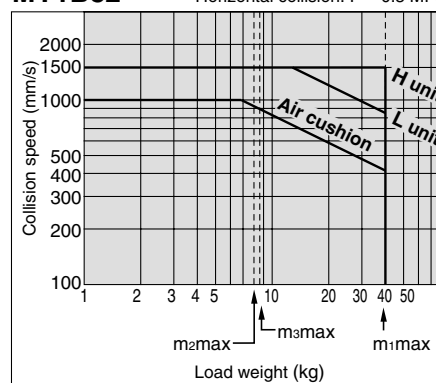

MY1B16 Horizontal collision: P = 0.5 MPa

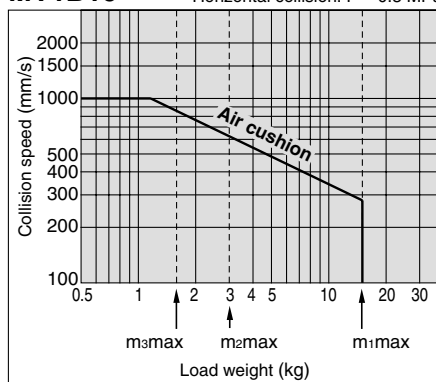

MY1B40 Horizontal collision: P = 0.5 MPa

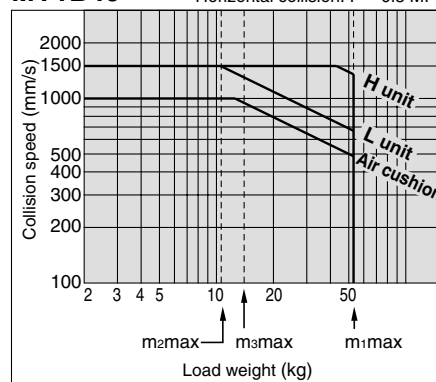

MY1B20 Horizontal collision: P = 0.5 MPa

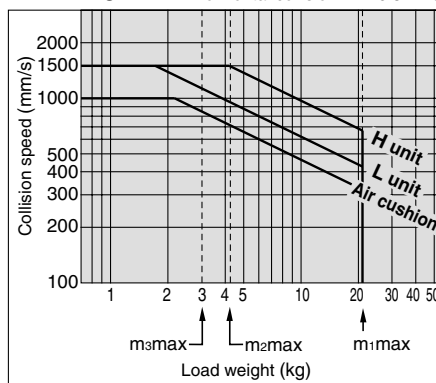

MY1B50 Horizontal collision: P = 0.5 MPa

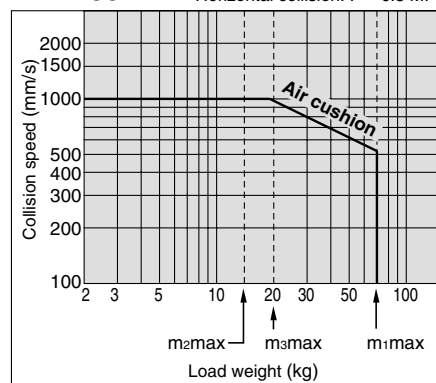

MY1B25 Horizontal collision: P = 0.5 MPa

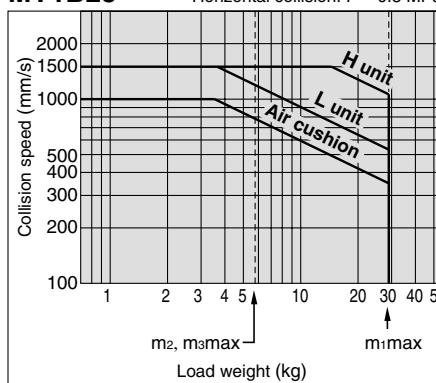

MY1B63 Horizontal collision: P = 0.5 MPa

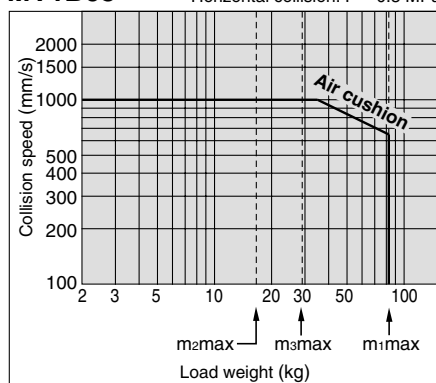

- MX
- MTS
- MY
- CY
- MG
- CX
- D-
- X
- 20-
- Data

Series MY1B

Cushion Capacity

Rubber Bumper/Air Cushion Stroke Adjustment Unit Absorption Capacity

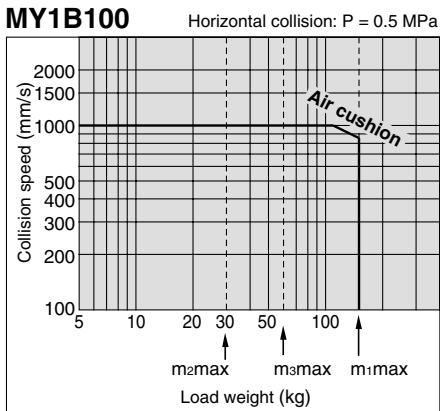
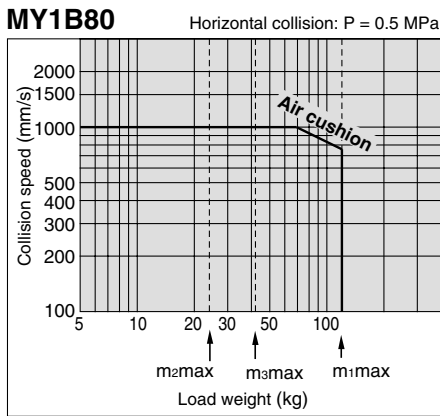

Air Cushion Stroke

Bore size (mm)	Cushion stroke
16	12
20	15
25	15
32	19
40	24
50	30
63	37
80	40
100	40

Rubber Bumper (ø10 only) Positive Stroke from One End Due to Pressure

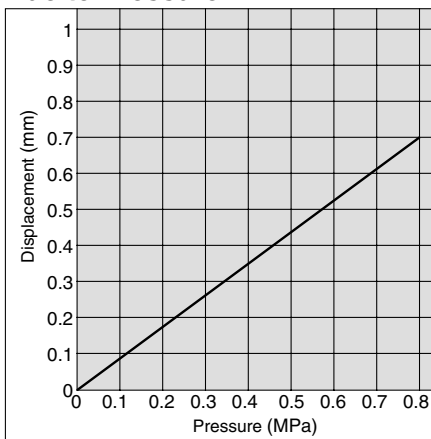

Tightening Torque for Stroke Adjusting Unit Holding Bolts

Bore size (mm)	Unit	Tightening torque (N·m)
10	A	0.3
	H	
16	A	0.6
	H	
20	A	1.5
	L	
25	A	3.0
	H	
32	A	5.0
	L	
40	A	10
	L	
	H	

Tightening Torque for Stroke Adjusting Unit Lock Plate Holding Bolts

Bore size (mm)	Unit	Tightening torque (N·m)
20	H	1.2
	L	
25	H	3.3
	L	
32	H	10
	L	
40	L	3.3
	H	

Calculation of Absorbed Energy for Stroke Adjusting Unit with Shock Absorber

Type of impact	Horizontal collision	Vertical (Downward)	Vertical (Upward)
Diagram			
Kinetic energy E ₁		$\frac{1}{2} m \cdot v^2$	
Thrust energy E ₂	F·s	F _s + m·g·s	F _s - m·g·s
Absorbed energy E	E ₁ + E ₂		

Symbol
 v: Speed of impact object (m/s)
 F: Cylinder thrust (N)
 s: Shock absorber stroke (m)
 m: Weight of impact object (kg)
 g: Gravitational acceleration (9.8 m/s²)
 Note) The speed of the impact object is measured at the time of impact with the shock absorber.

⚠ Precautions

Be sure to read before handling. For Safety Instructions and Actuator Precautions, refer to pages 8-34-3 to 8-34-6.

⚠ Caution

Use caution not to get your hands caught in the unit.

- When using a product with stroke adjusting unit, the space between the slide table (slider) and the stroke adjusting unit becomes narrow at the stroke end, causing a danger of hands getting caught. Install a protective cover to prevent direct contact with the human body.

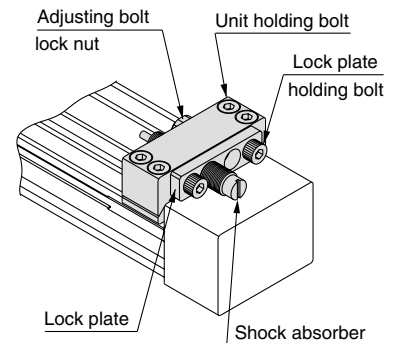

<Fastening of unit>

The unit can be secured by evenly tightening the four unit holding bolts.

⚠ Caution

Do not operate with the stroke adjusting unit fixed in an intermediate position.

When the stroke adjusting unit is fixed in an intermediate position, slippage can occur depending on the amount of energy released at the time of an impact. In such cases, the use of the adjusting bolt mounting brackets, available per made-to-order specifications -X416 and -X417, is recommended. (Except ø10)

For other lengths, please consult with SMC (Refer to "Tightening Torque for Stroke Adjusting Unit Holding Bolts".)

<Stroke adjustment with adjusting bolt>
 Loosen the adjusting bolt lock nut, and adjust the stroke from the lock plate side using a hexagon wrench. Retighten the lock nut.

<Stroke adjustment with shock absorber>

Loosen the two lock plate holding bolts, turn the shock absorber and adjust the stroke. Then, uniformly tighten the lock plate holding bolts to secure the shock absorber.

Take care not to over-tighten the holding bolts. (Except ø10 and ø20 L unit.) (Refer to "Tightening Torque for Stroke Adjusting Unit Lock Plate Holding Bolts".)

Note)

Although the lock plate may slightly bend due to tightening of the lock plate holding bolt, this does not affect the shock absorber and locking function.

Mechanically Jointed Rodless Cylinder Basic Type **Series MY1B**

Centralized Piping Type $\phi 10$

Refer to page 8-11-9 regarding centralized piping port variations.

MY1B10G — Stroke

MX

MTS

MY

CY

MG

CX

D-

-X

20-

Data

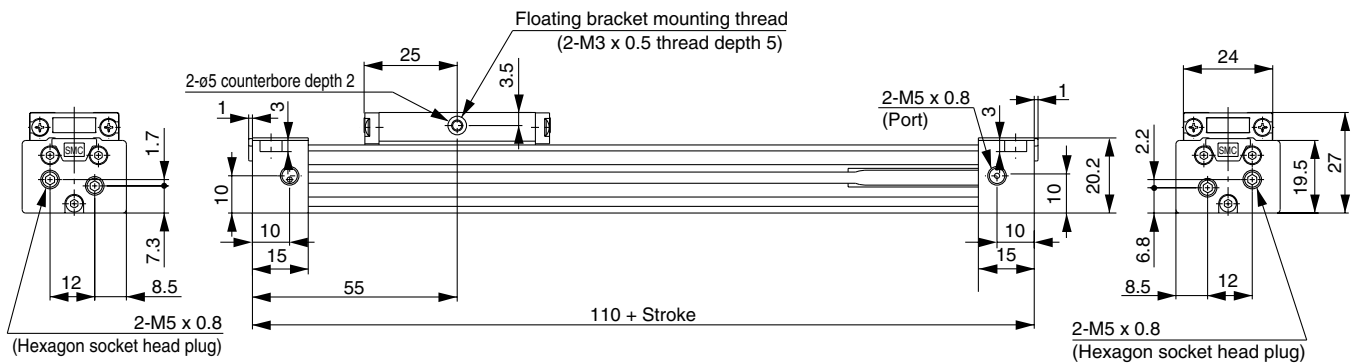
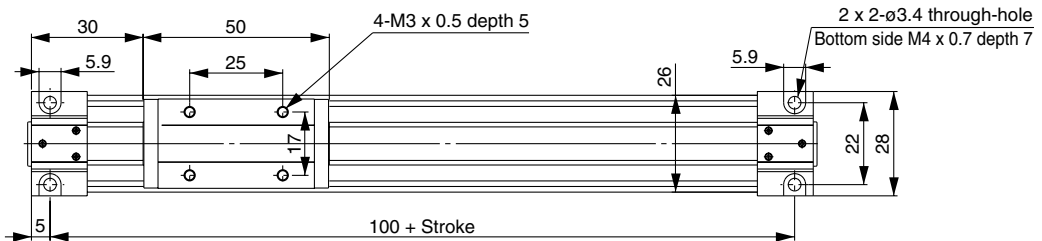
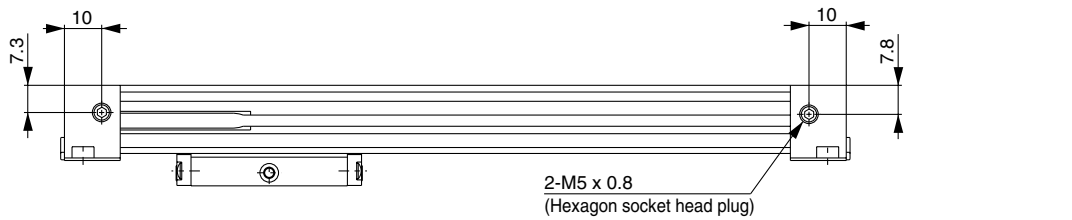

Series MY1B

Standard Type/Centralized Piping Type $\phi 50, \phi 63$

Refer to page 8-11-9 regarding centralized piping port variations.

MY1B50□/63□ — Stroke

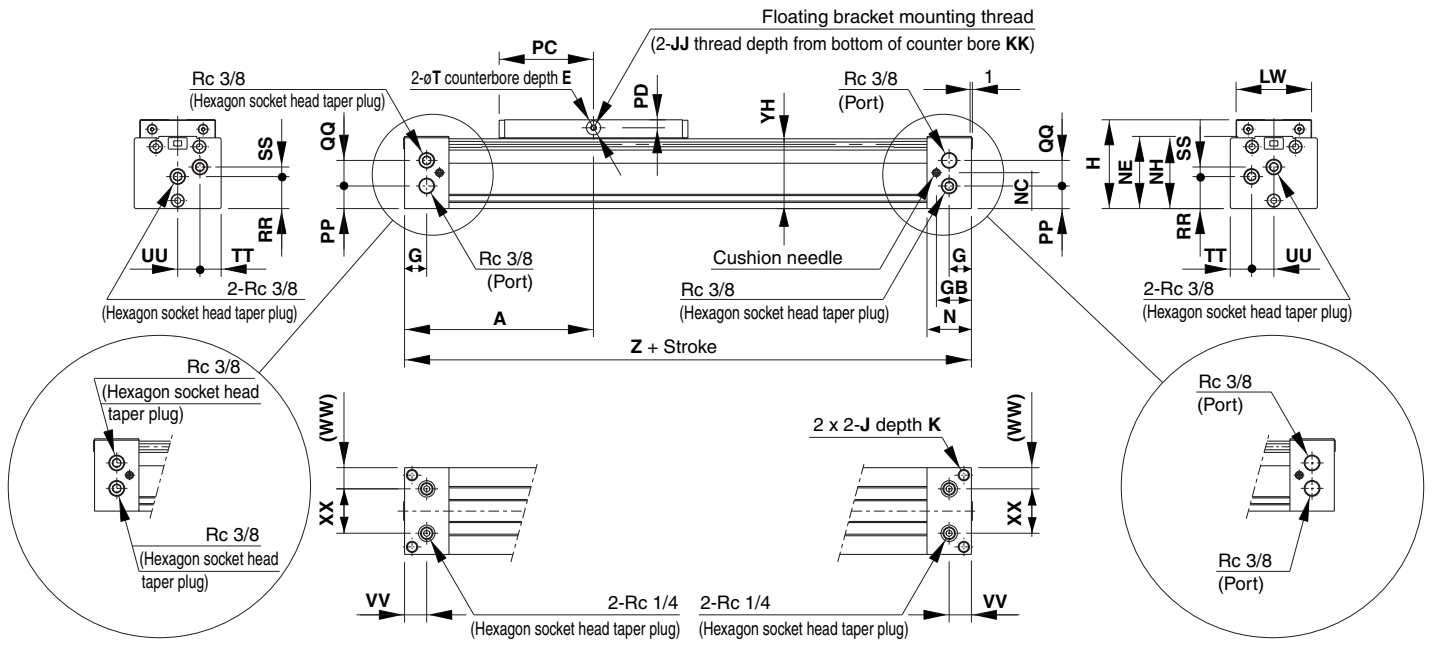
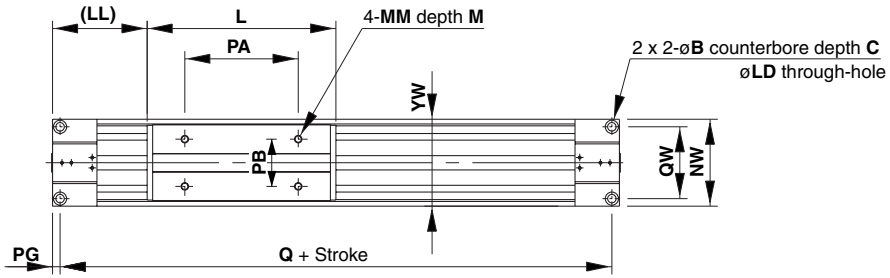

MY1B□G

MY1B□G

Model	A	B	C	E	G	GB	H	J	JJ	K	KK	L	LD	LL	LW	M	MM	N	NC	NE
MY1B50□	200	14	8.5	3	23.5	37	94	M12 x 1.75	M6 x 1	25	17	200	9	100	80	14	M8 x 1.25	47	38	76.5
MY1B63□	230	17	10.5	3	25	39	116	M14 x 2	M8 x 1.25	28	24	230	11	115	96	16	M8 x 1.25	50	51	100

Model	NH	NW	PA	PB	PC	PD	PG	PP	Q	QQ	QW	RR	SS	T	TT	UU	VV	WW	XX	YH	YW	Z
MY1B50□	75	92	120	50	100	8.5	8	24	384	27	76	34	10	15	22.5	23.5	23.5	22.5	47	74	92	400
MY1B63□	95	112	140	60	115	9.5	10	37.5	440	29.5	92	44.5	13.5	16	27	29	25	28	56	94	112	460

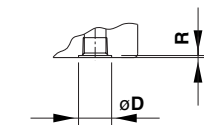
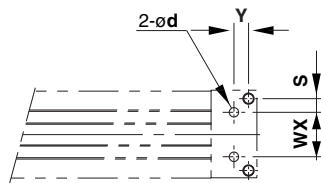

Bottom ported
(Applicable O-ring)

Hole Size for Centralized Piping on the Bottom

Model	WX	Y	S	d	D	R	Applicable O-ring
MY1B50□	47	15.5	14.5	10	17.5	1.1	C15
MY1B63□	56	15	18	10	17.5	1.1	

(Machine the mounting side to the dimensions below.)

Mechanically Jointed Rodless Cylinder Basic Type Series MY1B

Standard Type/Centralized Piping Type $\phi 80, \phi 100$

Refer to page 8-11-9 regarding centralized piping port variations.

MY1B80□/100□ — Stroke

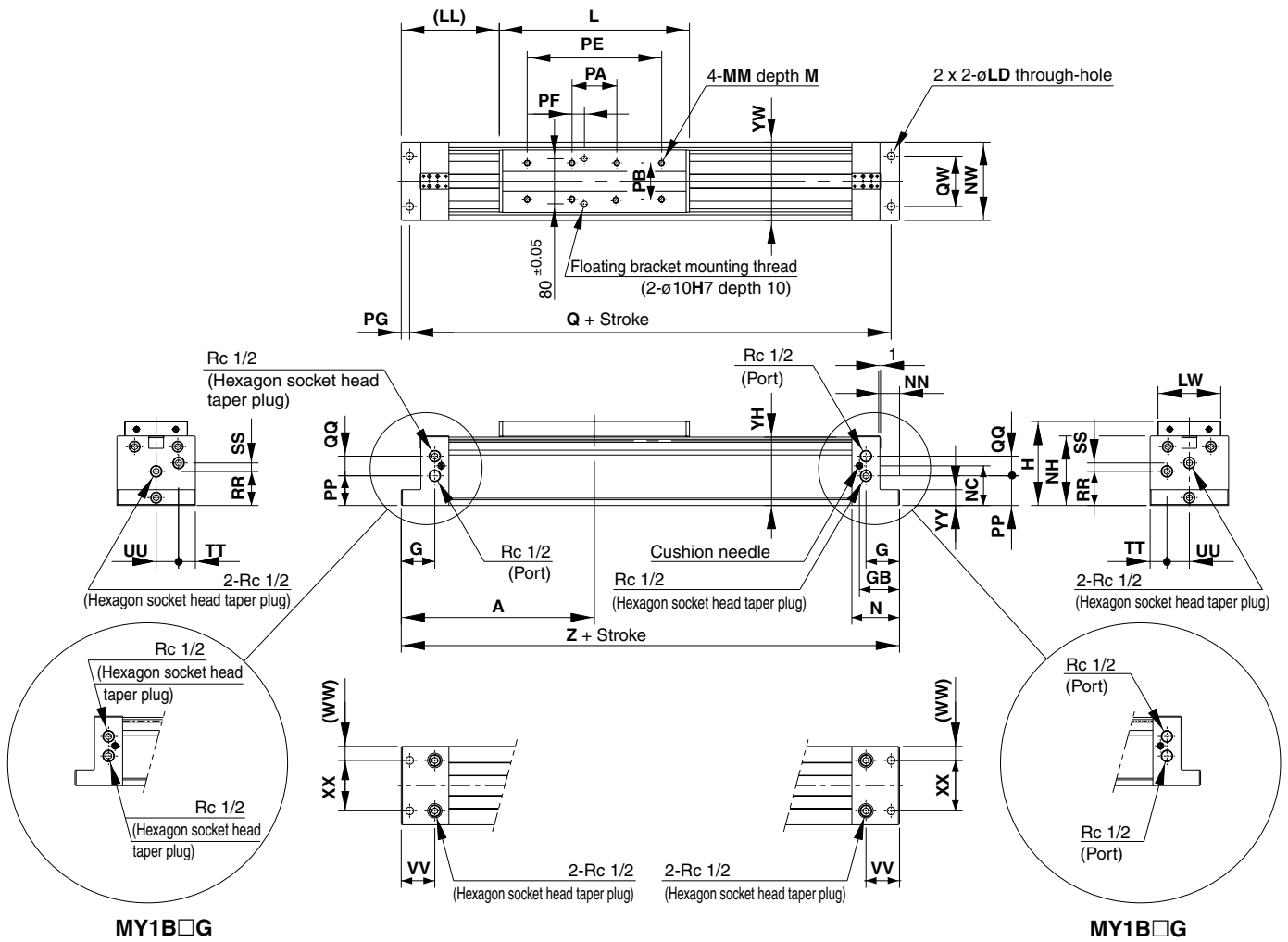

MX□

MTS

MY□

CY□

MG□

CX□

D-

-X

20-

Data

Model	A	G	GB	H	L	LD	LL	LW	M	MM	N	NC	NH	NN	NW	PA	PB	PE
MY1B80□	345	60	71.5	150	340	14	175	112	20	M10 x 1.5	85	65	124	35	140	80	65	240
MY1B100□	400	70	79.5	190	400	18	200	140	25	M12 x 1.75	95	85	157	45	176	120	85	280

(mm)

Model	PF	PG	PP	Q	QQ	QW	RR	SS	TT	UU	VV	WW	XX	YH	YW	YY	Z
MY1B80□	22	15	53	660	35	90	61	15	30	40	60	25	90	122	140	28	690
MY1B100□	42	20	69	760	38	120	75	20	40	48	70	28	120	155	176	35	800

(mm)

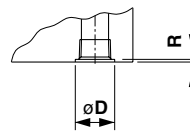
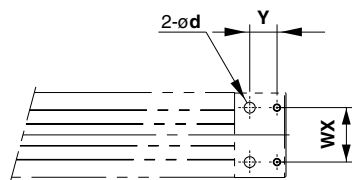

Bottom ported
(Applicable O-ring)

Hole Size for Centralized Piping on the Bottom

Model	WX	Y	d	D	R	Applicable O-ring
MY1B80□	90	45	18	26	1.8	P22
MY1B100□	120	50	18	26	1.8	

(Machine the mounting side to the dimensions below.)

Series MY1B

Stroke Adjusting Unit

With adjusting bolt

MY1B Bore size □ — Stroke A

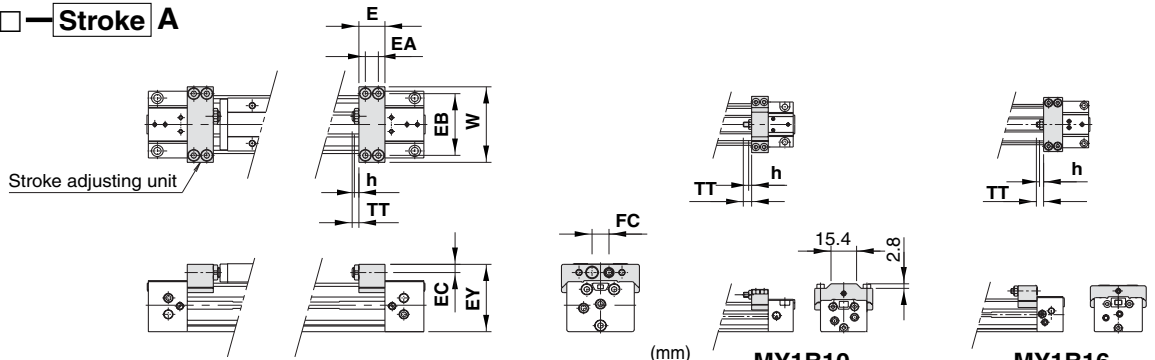

Applicable bore size	E	EA	EB	EC	EY	FC	h	TT	W
MY1B10	10	5	28	3.3	26.3	—	1.8	5 (Max. 10)	35
MY1B16	14.6	7	34.4	4.2	36.5	—	2.4	5.4 (Max. 11)	43
MY1B20	19	9	43	5.8	45.6	13	3.2	6 (Max. 12)	53
MY1B25	20	10	49	6.5	53.5	13	3.5	5 (Max. 16.5)	60
MY1B32	25	12	61	8.5	67	17	4.5	8 (Max. 20)	74
MY1B40	31	15	76	9.5	81.5	17	4.5	9 (Max. 25)	94

With low load shock absorber
+ Adjusting bolt

MY1B Bore size □ — Stroke L

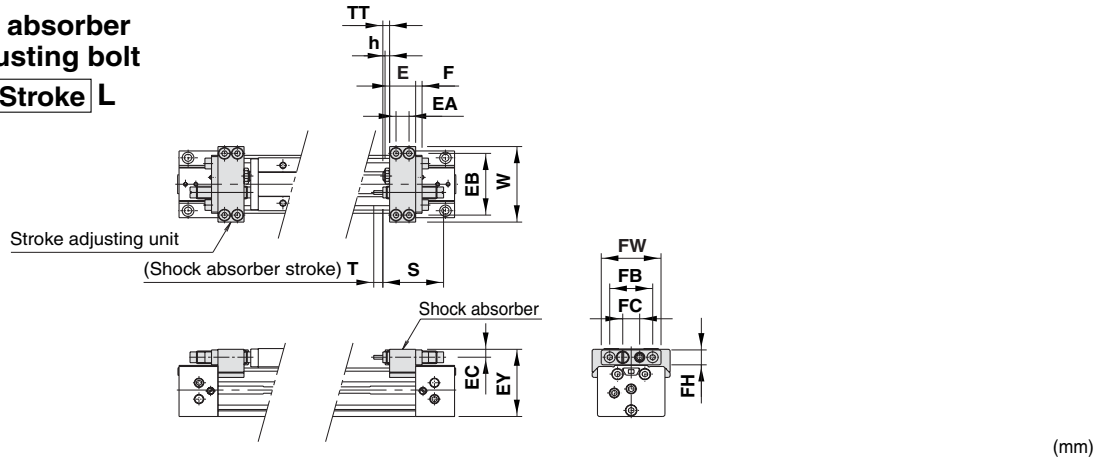

Applicable bore size	E	EA	EB	EC	EY	F	FB	FC	FH	FW	h	S	T	TT	W	Shock absorber model
MY1B20	19	9	43	5.8	45.6	4	—	13	—	—	3.2	40.8	6	6 (Max. 12)	53	RB0806
MY1B25	20	10	49	6.5	53.5	6	33	13	12	46	3.5	46.7	7	5 (Max. 16.5)	60	RB1007
MY1B32	25	12	61	8.5	67	6	43	17	16	56	4.5	67.3	12	8 (Max. 20)	74	RB1412
MY1B40	31	15	76	9.5	81.5	6	43	17	16	56	4.5	67.3	12	9 (Max. 25)	94	RB1412

With high load shock absorber
+ Adjusting bolt

MY1B Bore size □ — Stroke H

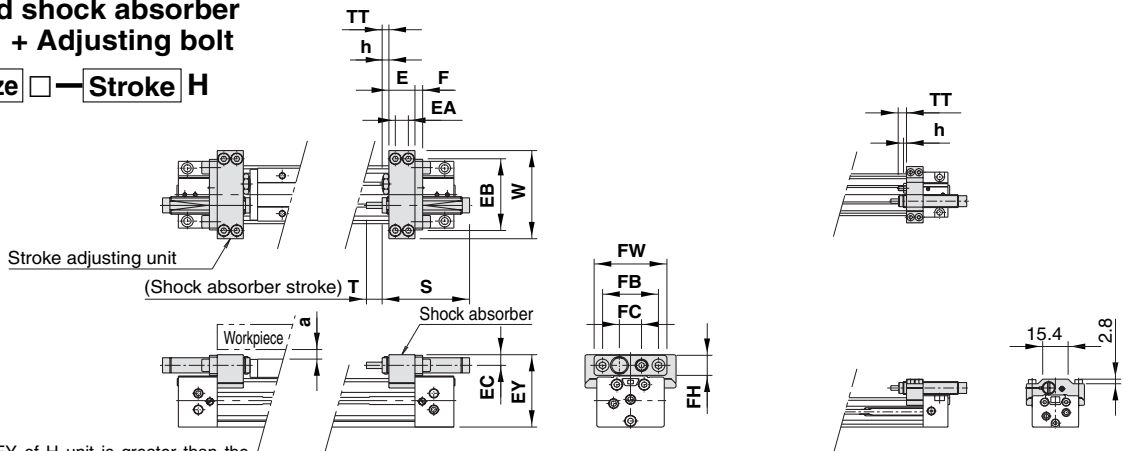

* Since the dimension EY of H unit is greater than the table top height (dimension H), when a workpiece is loaded that is larger than the full length (dimension L) of the slide table allow a clearance of size "a" or larger at the workpiece side.

MY1B10

Applicable bore size	E	EA	EB	EC	EY	F	FB	FC	FH	FW	h	S	T	TT	W	Shock absorber model	a
MY1B10	10	5	28	5.5	29.8	—	—	8	—	—	1.8	40.8	5	5 (Max. 10)	35	RB0805	3.5
MY1B20	20	10	49	6.5	47.5	6	33	13	12	46	3.5	46.7	7	5 (Max. 11)	60	RB1007	2.5
MY1B25	20	10	57	8.5	57.5	6	43	17	16	56	4.5	67.3	12	5 (Max. 16.5)	70	RB1412	4.5
MY1B32	25	12	74	11.5	73	8	57	22	22	74	5.5	73.2	15	8 (Max. 20)	90	RB2015	6
MY1B40	31	15	82	12	87	8	57	22	22	74	5.5	73.2	15	9 (Max. 25)	100	RB2015	4

Side Support

Side support A MY-S□A

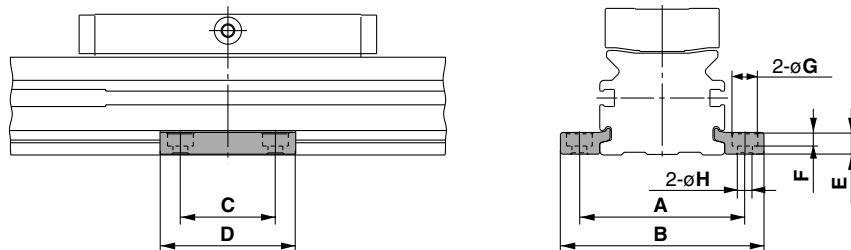

Side support B MY-S□B

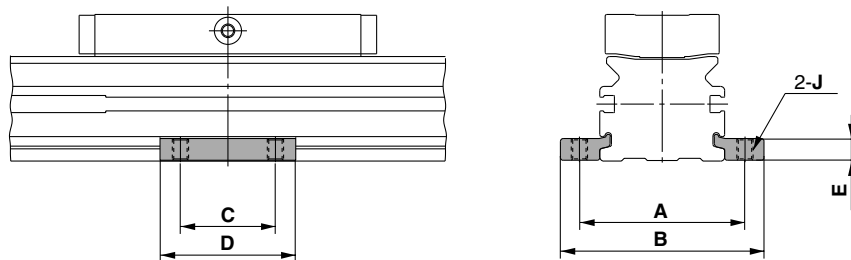

Model	Applicable bore size	A	B	C	D	E	F	G	H	J
MY-S10 ^A _B	MY1B10	35	43.6	12	21	3.6	1.8	6.5	3.4	M4 x 0.7
MY-S16 ^A _B	MY1B16	43	53.6	15	26	4.9	3	6.5	3.4	M4 x 0.7
MY-S20 ^A _B	MY1B20	53	65.6	25	38	6.4	4	8	4.5	M5 x 0.8
MY-S25 ^A _B	MY1B25	61	75	35	50	8	5	9.5	5.5	M6 x 1
	MY1B32	70	84							
MY-S32 ^A _B	MY1B40	87	105	45	64	11.7	6	11	6.6	M8 x 1.25
	MY1B50	113	131							
MY-S50 ^A _B	MY1B63	136	158	55	80	14.8	8.5	14	9	M10 x 1.5
MY-S63 ^A _B	MY1B80	170	200	70	100	18.3	10.5	17.5	11.5	M12 x 1.75
	MY1B100	206	236							

- MX□
- MTS
- MY□**
- CY□
- MG□
- CX□
- D-
- X
- 20-
- Data

Guide for Side Support Application

For long stroke operation, the cylinder tube may be deflected depending on its own weight and the load weight. In such a case, use a side support in the middle section. The spacing (ℓ) of the support must be no more than the values shown in the graph on the right.

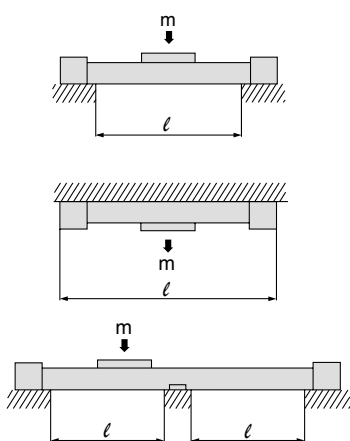

⚠ Caution

- If the cylinder mounting surfaces are not measured accurately, using a side support may cause poor operation. Therefore, be sure to level the cylinder tube when mounting. Also, for long stroke operation involving vibration and impact, use of a side support is recommended even if the spacing value is within the allowable limits shown in the graph.
- Support brackets are not for mounting; use them solely for providing support.

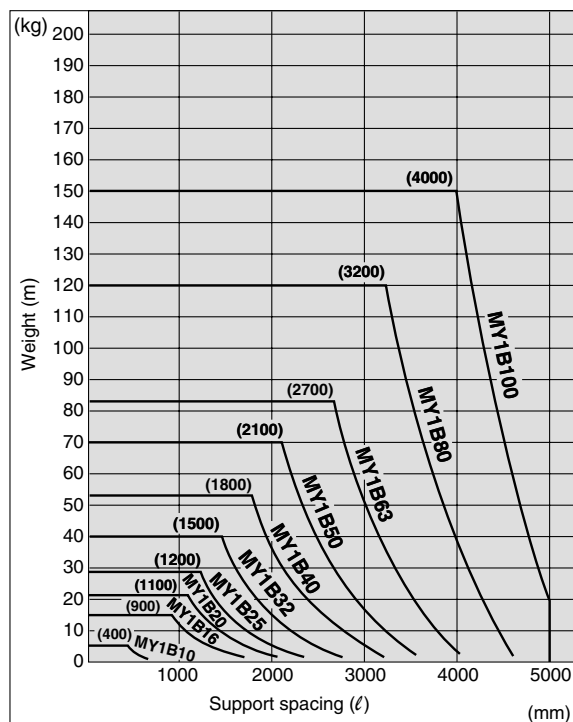

Series MY1B

Floating Bracket

Facilitates connection to other guide systems.

Applicable bore size



Application Example

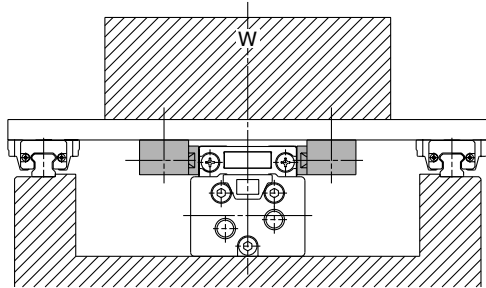

Mounting Example

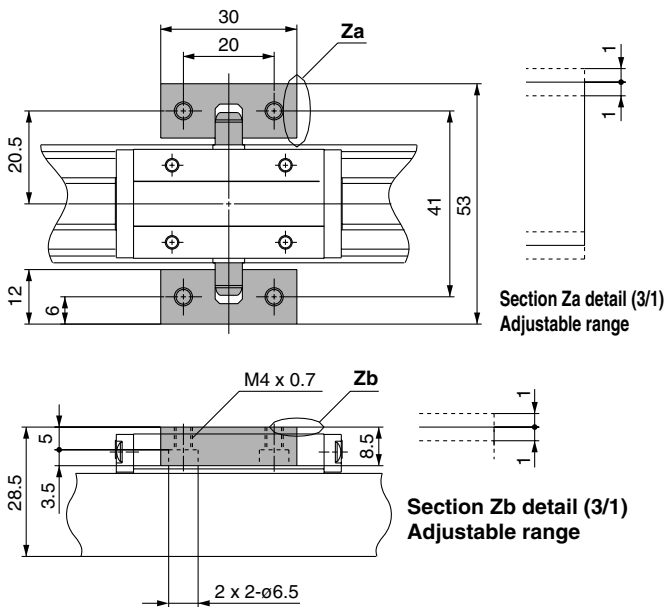

Applicable bore size

ø16, ø20

Application Example

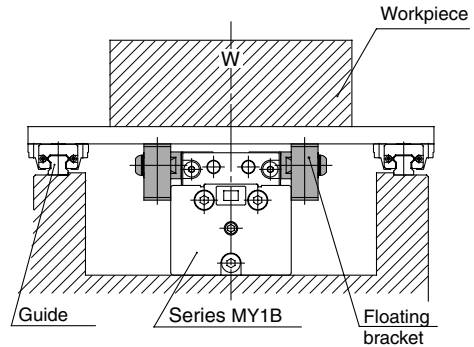

Mounting Example

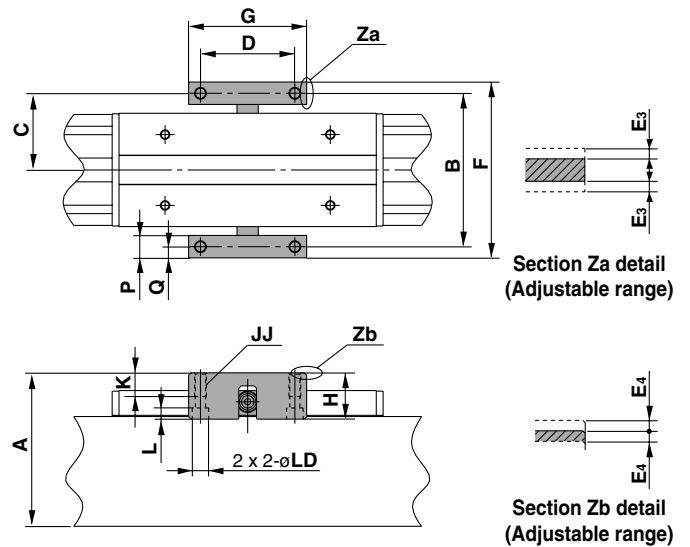

(mm)

Model	Applicable bore size	A	B	C	D	F	G	H
MY-J16	MY1B16□	45	45	22.5	30	52	38	18
MY-J20	MY1B20□	55	52	26	35	59	50	21

Model	Applicable bore size	JJ	K	L	P	Q	E ₃	E ₄	LD
MY-J16	MY1B16□	M4 x 0.7	10	4	7	3.5	1	1	6
MY-J20	MY1B20□	M4 x 0.7	10	4	7	3.5	1	1	6

Installation of Holding Bolts

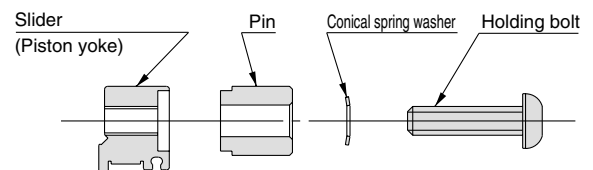

Tightening Torque for Holding Bolts

(N·m)

Model	Tightening torque	Model	Tightening torque	Model	Tightening torque
MY-J10	0.6	MY-J25	3	MY-J50	5
MY-J16	1.5	MY-J32	5	MY-J63	13
MY-J20	1.5	MY-J40	5		

Mechanically Jointed Rodless Cylinder Basic Type Series MY1B

Applicable bore size

ø25, ø32, ø40

Application Example

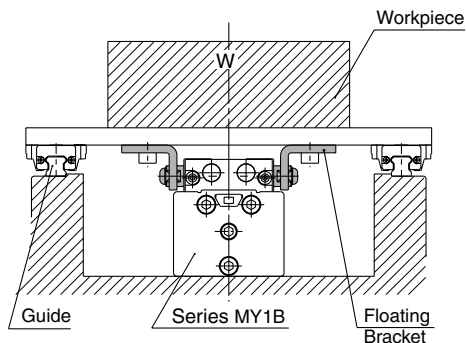

Mounting Example

One set of brackets can be mounted in two directions for compact combinations.

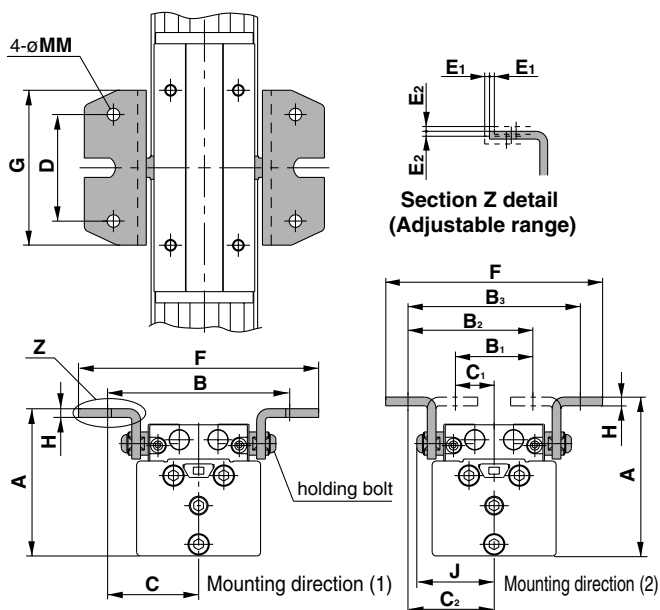

Model	Applicable bore size	Common					Mounting direction (2)			
		D	G	H	J	MM	A	B	C	F
MY-J25	MY1B25□	40	60	3.2	35	5.5	63	78	39	100
MY-J32	MY1B32□	55	80	4.5	40	6.5	76	94	47	124
MY-J40	MY1B40□	74	100	4.5	47	6.5	92	112	56	144

Model	Applicable bore size	Mounting direction (1)					Adjustable range			
		A	B ₁	B ₂	B ₃	C ₁	C ₂	F	E ₁	E ₂
MY-J25	MY1B25□	65	28	53	78	14	39	96	1	1
MY-J32	MY1B32□	82	40	64	88	20	44	111	1	1
MY-J40	MY1B40□	98	44	76	108	22	54	131	1	1

Note) One set of floating brackets consists of one right piece and one left piece.

Applicable bore size

ø50, ø63

Application Example

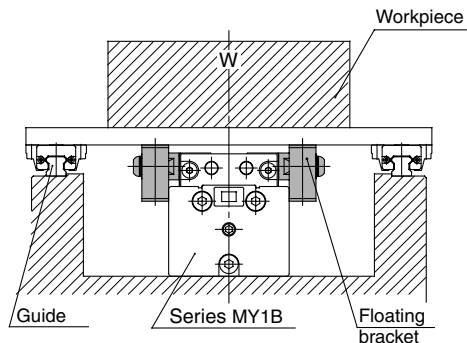

Mounting Example

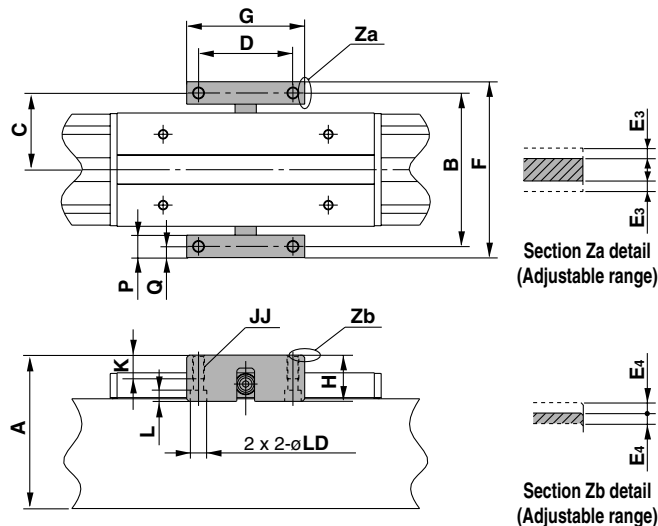

Model	Applicable bore size	A	B	C	D	F	G	H
MY-J50	MY1B50□	110	110	55	70	126	90	37
MY-J63	MY1B63□	131	130	65	80	149	100	37

Model	Applicable bore size	JJ	K	L	P	Q	E ₃	E ₄	LD
MY-J50	MY1B50□	M8 x 1.25	20	7.5	16	8	2.5	2.5	11
MY-J63	MY1B63□	M10 x 1.5	20	9.5	19	9.5	2.5	2.5	14

- MX□
- MTS
- MY□
- CY□
- MG□
- CX□
- D-
- X
- 20-
- Data

Series MY1B

Floating Bracket

Facilitates connection to other guide systems.

Applicable bore size

ø80, ø100

Application Example

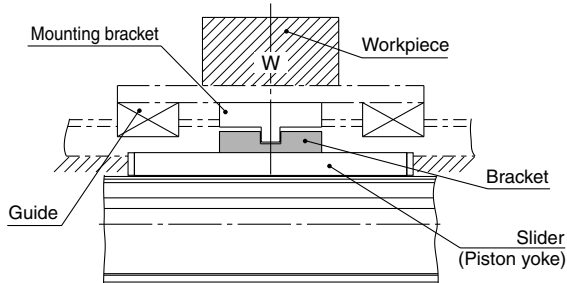

Mounting Example

Support bracket mounting area is heat treated at HRC40 or above.

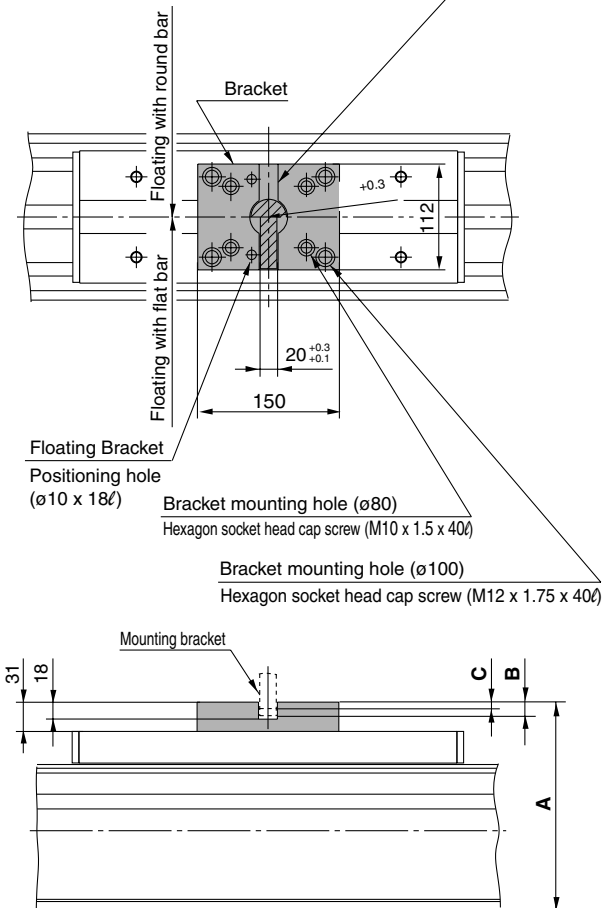

Hexagon Socket Head Cap Screw Tightening Torque (N·m)

Model	Applicable bore size	A	B (max)	C (min)	Model	Tightening torque
MY-J 80	MY1B80□	181	15	9	MY-J80	25
MY-J100	MY1B100□	221	15	9	MY-J100	44

- Note) • Flat bar or round bar mounting are possible for the support bracket (slanted lines) mounted by the customer.
 • The floating bracket is shipped together with (4) hexagon socket head cap screws and (2) parallel pins at the time of shipment.
 • "B" and "C" indicate the allowable mounting dimensions for the support bracket (flat bar or round bar).
 • Consider support brackets with dimensions that allow the floating mechanism to function properly.

Floating Bracket Operating Precautions

⚠ Caution

Make sure that the amount of divergence from the external guide is within the adjustable range.

Using the floating bracket facilitates connection to an external guide. However, with a rod type guide, etc., the amount of displacement is large and the floating bracket may not be able to absorb the variation. Check the amount of displacement and mount the floating bracket within the adjustable range.

When the displacement amount exceeds the adjustable range, use a separate floating mechanism.

Mechanically Jointed Rodless Cylinder Basic Type Series MY1B

Construction: ø10

Centralized piping type: MY1B10G

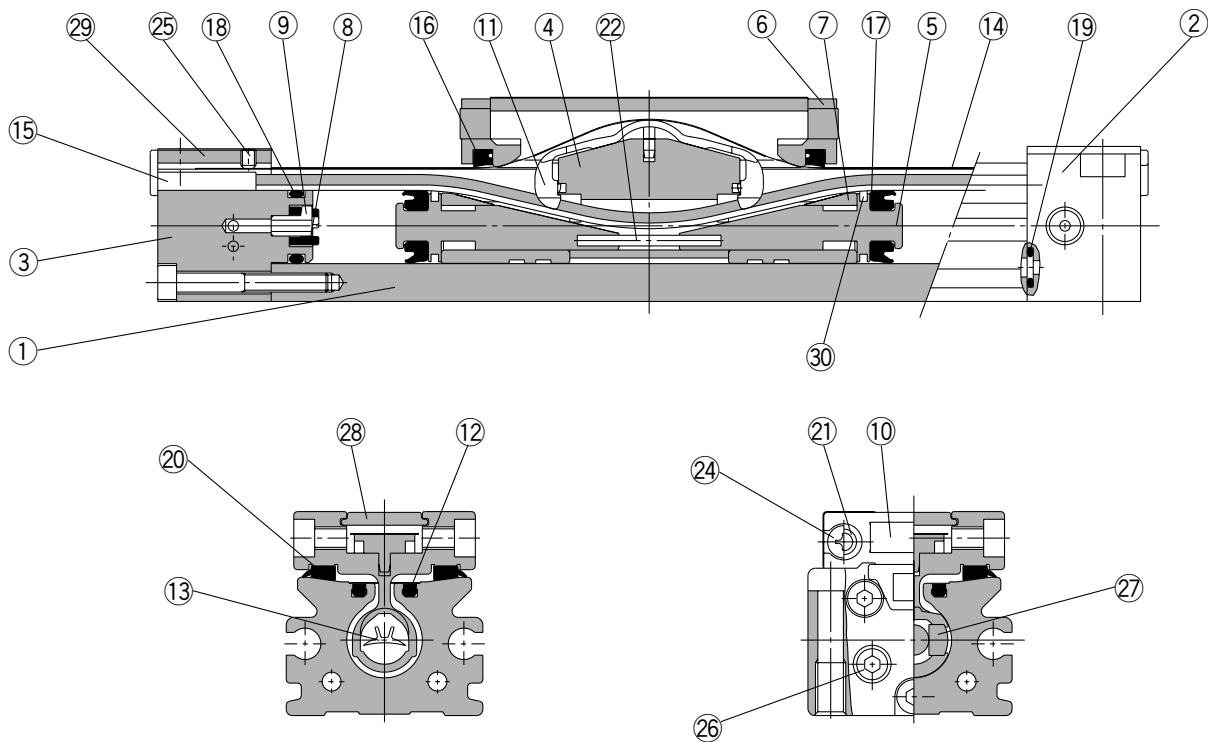

MX

MTS

MY

CY

MG

CX

D-

-X

20-

Data

Component Parts

No.	Description	Material	Note
①	Cylinder tube	Aluminum alloy	Hard anodized
②	Head cover WR	Aluminum alloy	Painted
③	Head cover WL	Aluminum alloy	Painted
④	Piston yoke	Aluminum alloy	Hard anodized
⑤	Piston	Aluminum alloy	Chromated
⑥	End Cover	Special resin	
⑦	Wear ring	Special resin	
⑧	Bumper	Polyurethane rubber	
⑨	Holder	Stainless steel	
⑩	Stopper	Carbon steel	Nickel plated
⑪	Belt separator	Special resin	
⑫	Seal magnet	Rubber magnet	

No.	Description	Material	Note
⑮	Belt clamp	Special resin	
⑯	Bearing	Special resin	
⑰	Spacer	Chromium molybdenum steel	Nickel plated
⑱	Spring pin	Stainless steel	
⑲	Hexagon socket head cap screw	Chromium molybdenum steel	Nickel plated
⑳	Round head Phillips screw	Carbon steel	Nickel plated
㉑	Hexagon socket head set screw	Carbon steel	Black zinc chromated
㉒	Hexagon socket head plug	Carbon steel	Nickel plated
㉓	Magnet	Rare earth magnet	
㉔	Top plate	Stainless steel	
㉕	Head plate	Stainless steel	
㉖	Felt	Felt	

Seal List

No.	Description	Material	Qty.	MY1B10
⑬	Seal belt	Special resin	1	MY10-16A-Stroke
⑭	Dust seal band	Stainless steel	1	MY10-16B-Stroke
⑯	Scraper	NBR	2	MYB10-15AR0597
⑰	Piston seal	NBR	2	GM10
⑱	Tube gasket	NBR	2	P7
⑲	O-ring	NBR	4	ø5.33 x ø3.05 x ø1.14

Series MY1B

Construction: $\varnothing 16$ to $\varnothing 100$

MY1B16 to 100

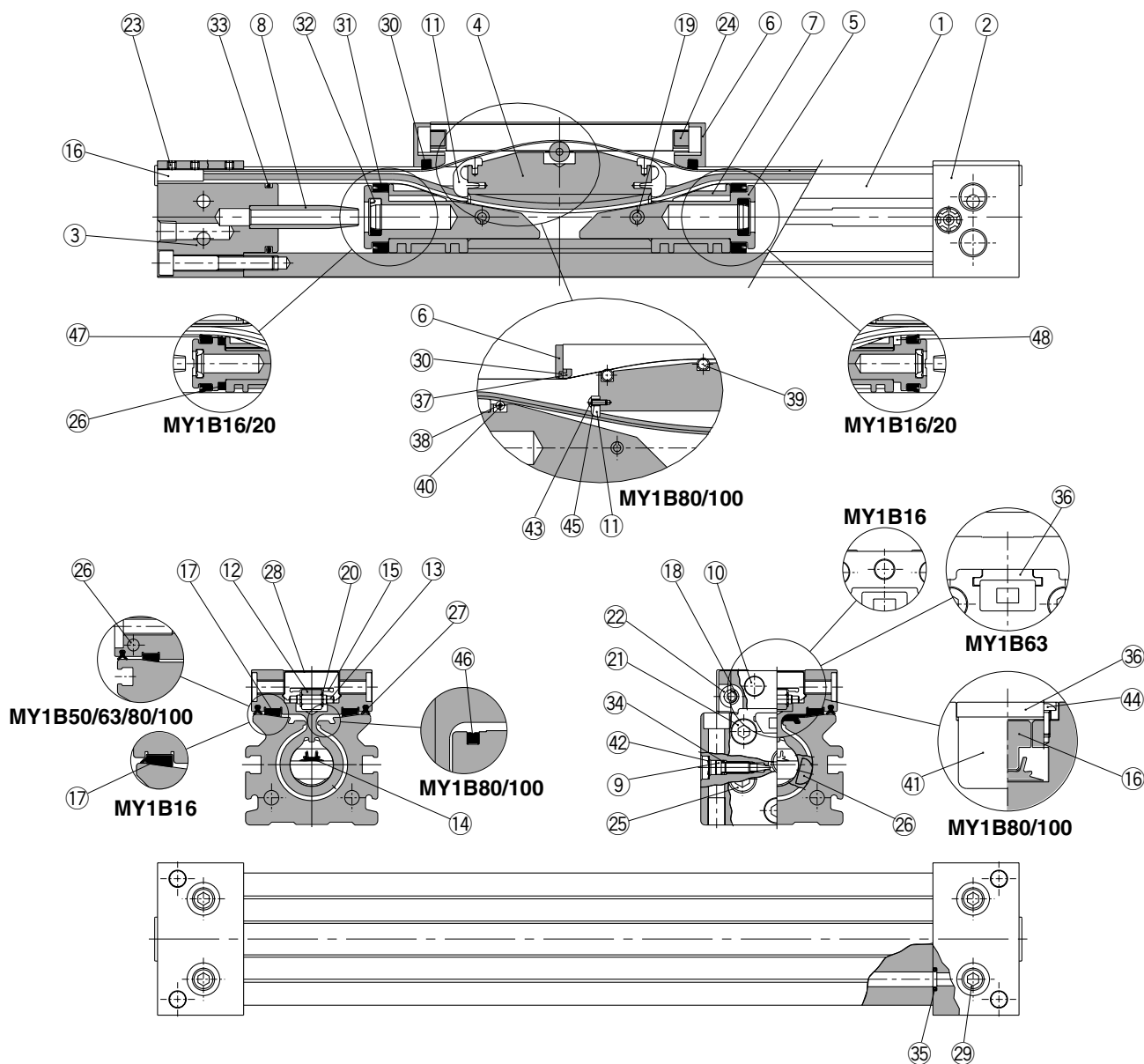

Mechanically Jointed Rodless Cylinder Basic Type Series MY1B

Construction: ø16 to ø100

MY1B16 to 100

Component Parts

No.	Description	Material	Note
①	Cylinder tube	Aluminum alloy	Hard anodized
②	Head cover WR	Aluminum alloy	Painted
③	Head cover WL	Aluminum alloy	Painted
④	Piston yoke	Aluminum alloy	Hard anodized
⑤	Piston	Aluminum alloy	Chromated
⑥	End cover	Special resin	
		Carbon steel	Nickel plated (ø80, ø100)
⑦	Wear ring	Special resin	
⑧	Cushion ring	Brass	
⑨	Cushion needle	Rolled steel	Nickel plated
⑩	Stopper	Carbon steel	Nickel plated
⑪	Belt separator	Special resin	
⑫	Guide roller	Special resin	
⑬	Guide roller shaft	Stainless steel	
⑯	Belt clamp	Special resin	
		Aluminum alloy	Chromated (ø80, ø100)
⑰	Bearing	Special resin	
⑱	Spacer	Stainless steel	
⑲	Spring pin	Carbon tool steel	Black zinc chromated
⑳	Type E snap ring	Cold rolled special steel strip	
㉑	Hexagon socket head cap screw	Chromium molybdenum steel	Nickel plated
㉒	Hexagon socket button head screw	Chromium molybdenum steel	Nickel plated
㉓	Hexagon socket head set screw	Chromium molybdenum steel	Black zinc chromated/ Nickel plated
㉔	Double round parallel key	Carbon steel	(ø16 to ø40)
㉕	Hexagon socket head taper plug	Carbon steel	Nickel plated

No.	Description	Material	Note
㉖	Magnet	Rare earth magnet	
㉗	Top cover	Stainless steel	
㉘	Hexagon socket head taper plug	Carbon steel	Nickel plated
㉙	Head plate	Aluminum alloy	Hard anodized (ø63 to ø100)
㉚	Backup plate	Special resin	(ø63 to ø100)
㉛	Guide roller B	Special resin	(ø80, ø100)
㉜	Guide roller A	Stainless steel	(ø80, ø100)
㉝	Guide roller shaft B	Stainless steel	(ø80, ø100)
㉞	Side cover	Aluminum alloy	Hard anodized (ø80, ø100)
㉟	Type CR snap ring	Spring steel	
㊱	Hexagon socket button head screw	Chromium molybdenum steel	Nickel plated (ø80, ø100)
㊲	Hexagon socket button head screw	Chromium molybdenum steel	Nickel plated (ø80, ø100)
㊳	Spacer B	Stainless steel	(ø80, ø100)
㊴	Seal magnet	Rubber magnet	(ø80, ø100)
㊵	Felt A	Felt	(ø16, ø20)
㊶	Felt B	Felt	(ø16, ø20)

MX□

MTS

MY□

CY□

MG□

CX□

D-

-X

20-

Data

Seal List

No.	Description	Material	Qty.	MY1B16	MY1B20	MY1B25	MY1B32	MY1B40
⑭	Seal belt	Special resin	1	MY16-16A-Stroke	MY20-16A-Stroke	MY25-16A-Stroke	MY32-16A-Stroke	MY40-16A-Stroke
⑮	Dust seal band	Stainless steel	1	MY16-16B-Stroke	MY20-16B-Stroke	MY25-16B-Stroke	MY32-16B-Stroke	MY40-16B-Stroke
㉗	Side scraper	Special resin	2		MYB20-15CA7164B	MYB25-15BA5900B	MYB32-15BA5901B	MYB40-15BA5902B
⑳	Scraper	NBR	2	MYB16-15AA7163	MYB20-15AA7164	MYB25-15AA5900	MYB32-15AA5901	MYB40-15AA5902
㉙	Piston seal	NBR	2	GMYP16	GMYP20	GMYP25	GMYP32	GMYP40
㉚	Cushion seal	NBR	2	MYB16-15-A7163	MYB20-15-A7164	RCS-8	RCS-10	RCS-12
㉛	Tube gasket	NBR	2	P12	P16	TMY-25	TMY-32	TMY-40
㉜	O-ring	NBR	2	ø4 x ø1.8 x ø1.1	ø4 x ø1.8 x ø1.1	ø5.1 x ø3 x ø1.05	ø7.15 x ø3.75 x ø1.7	ø7.15 x ø3.75 x ø1.7
㉝	O-ring	NBR	4	ø6.2 x ø3 x ø1.6	ø7 x ø4 x ø1.5	P-5	P-6	C-9

No.	Description	Material	Qty.	MY1B50	MY1B63	MY1B80	MY1B100
⑭	Seal belt	Special resin	1	MY50-16A-Stroke	MY63-16A-Stroke	MY80-16A-Stroke	MY100-16A-Stroke
⑮	Dust seal band	Stainless steel	1	MY50-16B-Stroke	MY63-16B-Stroke	MY80-16B-Stroke	MY100-16B-Stroke
㉗	Side scraper	Special resin	2	MYB50-15CA7165B	MYB63-15CA7166B	MYB80-15CK2470B	MYB100-15CK2471B
⑳	Scraper	NBR	2	MYB50-15AA7165	MYB63-15AA7166	MYB80-15AK2470	MYB100-15AK2471
㉙	Piston seal	NBR	2	GMYP50	GMYP63	GMYP80	GMYP100
㉚	Cushion seal	NBR	2	MC-16	MC-20	MC-25	MC-30
㉛	Tube gasket	NBR	2	P44	P53	P70	P90
㉜	O-ring	NBR	2	ø8.3 x ø4.5 x ø1.9	C-4	C-6	C-6
㉝	O-ring	NBR	4	C-12.5	C-14	P22	P24

Note) Two types of dust seal band are available. Verify the type to use, since the part number varies depending on the treatment of the hexagon socket head set screw ㉓.

(A) Black zinc chromated → MY□□-16B-Stroke (B) Nickel plated → MY□□-16BW-Stroke

Series MY1M

Slide Bearing Guide Type

ø16, ø20, ø25, ø32, ø40, ø50, ø63

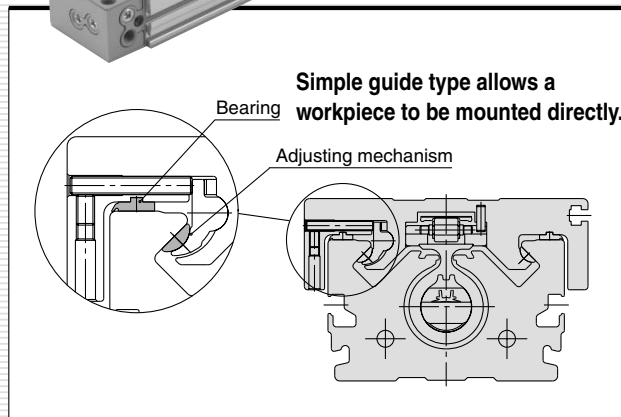
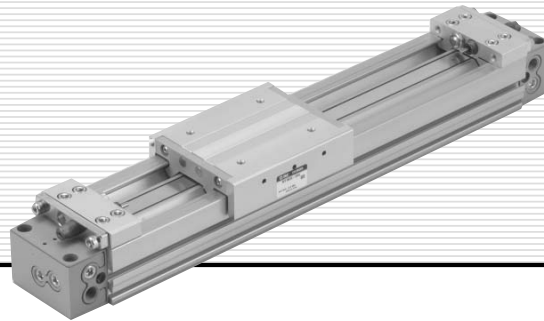

MX

MTS

MY

CY

MG

CX

D-

-X

20-

Data

Series MY1M

Before Operation

Maximum Allowable Moment/Maximum Load Weight

Model	Bore size (mm)	Maximum allowable moment (N·m)			Maximum load weight (kg)		
		M ₁	M ₂	M ₃	m ₁	m ₂	m ₃
MY1M	16	6.0	3.0	1.0	18	7	2.1
	20	10	5.2	1.7	26	10.4	3
	25	15	9.0	2.4	38	15	4.5
	32	30	15	5.0	57	23	6.6
	40	59	24	8.0	84	33	10
	50	115	38	15	120	48	14
	63	140	60	19	180	72	21

The above values are the maximum allowable values for moment and load. Refer to each graph regarding the maximum allowable moment and maximum allowable load for a particular piston speed.

Maximum Allowable Moment

Select the moment from within the range of operating limits shown in the graphs. Note that the maximum allowable load value may sometimes be exceeded even within the operating limits shown in the graphs. Therefore, also check the allowable load for the selected conditions.

Load weight (kg)

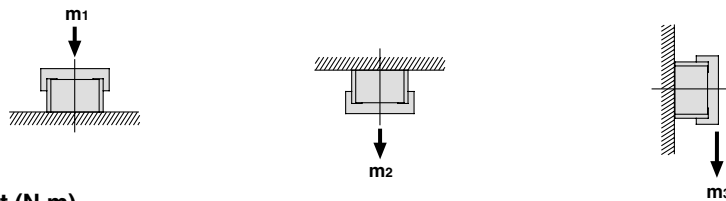

Moment (N·m)

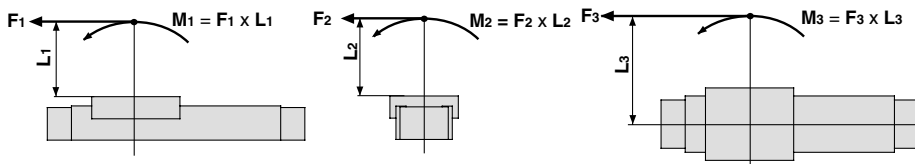

<Calculation of guide load factor>

1. Maximum allowable load (1), static moment (2), and dynamic moment (3) (at the time of impact with stopper) must be examined for the selection calculations.

* To evaluate, use \bar{v} (average speed) for (1) and (2), and v (collision speed $v = 1.4\bar{v}$) for (3). Calculate m_{max} for (1) from the maximum allowable load graph (m_1, m_2, m_3) and M_{max} for (2) and (3) from the maximum allowable moment graph (M_1, M_2, M_3).

$$\text{Sum of guide load factors } \Sigma\alpha = \frac{\text{Load weight [m]}}{\text{Maximum allowable load [m}_{max}\text{]}} + \frac{\text{Static moment [M]}^{(1)}}{\text{Allowable static moment [M}_{max}\text{]}} + \frac{\text{Dynamic moment [M}_E\text{]}^{(2)}}{\text{Allowable dynamic moment [M}_{E,max}\text{]}} \leq 1$$

Note 1) Moment caused by the load, etc., with cylinder in resting condition.

Note 2) Moment caused by the impact load equivalent at the stroke end (at the time of impact with stopper).

Note 3) Depending on the shape of the workpiece, multiple moments may occur. When this happens, the sum of the load factors ($\Sigma\alpha$) is the total of all such moments.

2. Reference formula [Dynamic moment at impact]

Use the following formulae to calculate dynamic moment when taking stopper impact into consideration.

- | | |
|--|--|
| m: Load weight (kg) | v : Collision speed (mm/s) |
| F: Load (N) | L_1 : Distance to the load's center of gravity (m) |
| F_E : Load equivalent to impact (at impact with stopper) (N) | M_E : Dynamic moment (N·m) |
| \bar{v} : Average speed (mm/s) | δ : Damper coefficient |
| M: Static moment (N·m) | At collision: $v = 1.4\bar{v}$ |
| | With rubber bumper = 4/100 |
| | (MY1B10, MY1H10) |
| | With air cushion = 1/100 |
| | With shock absorber = 1/100 |
| | g : Gravitational acceleration (9.8 m/s ²) |

$$v = 1.4\bar{v} \text{ (mm/s)} \quad F_E = 1.4\bar{v} \cdot \delta \cdot m \cdot g \text{ (Note 4)}$$

$$\therefore M_E = \frac{1}{3} \cdot F_E \cdot L_1 = 4.57\bar{v} \delta m L_1 \text{ (N·m) (Note 5)}$$

Note 4) $1.4\bar{v} \delta$ is a dimensionless coefficient for calculating impact force.

Note 5) Average load coefficient ($= \frac{1}{3}$): This coefficient is for averaging the maximum load moment at the time of stopper impact according to service life calculations.

3. For detailed selection procedures, refer to pages 8-11-38 to 8-11-39.

Maximum Load Weight

Select the load from within the range of limits shown in the graphs. Note that the maximum allowable moment value may sometimes be exceeded even within the operating limits shown in the graphs. Therefore, also check the allowable moment for the selected conditions.

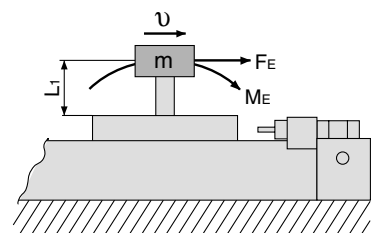

Mechanically Jointed Rodless Cylinder Slide Bearing Guide Type **Series MY1M**

MY1M/M₁

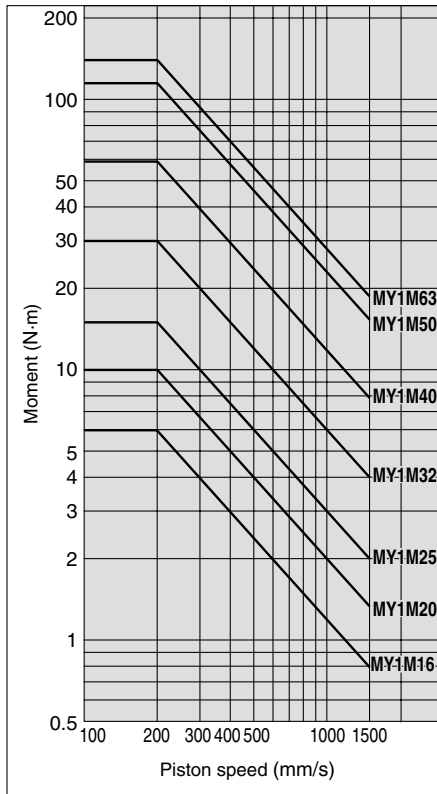

MY1M/M₂

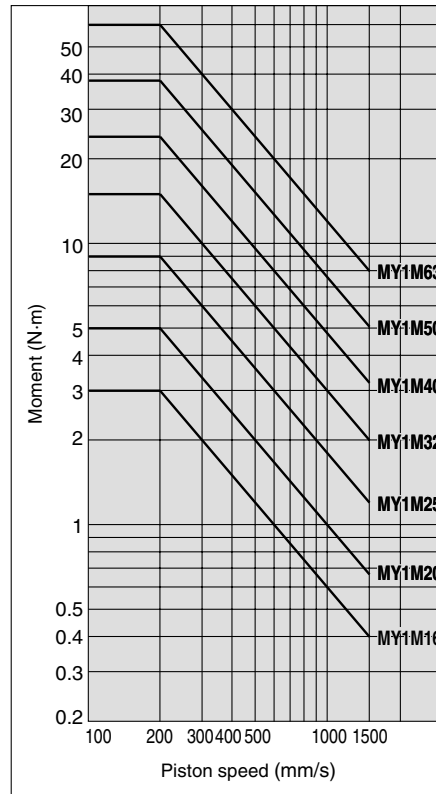

MY1M/M₃

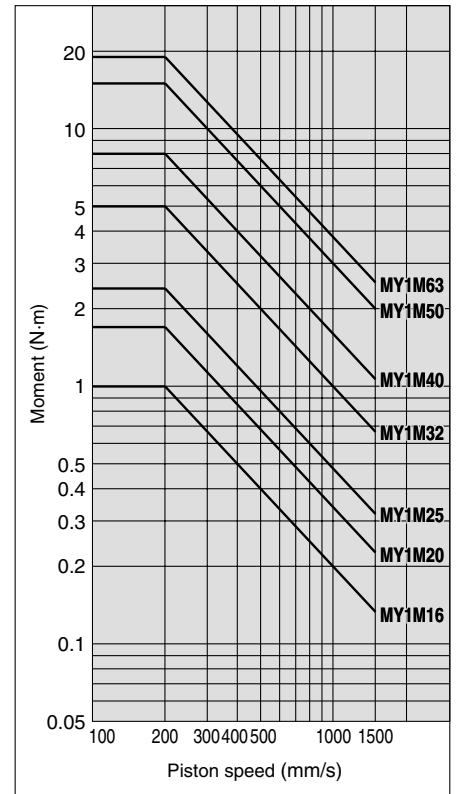

MX

MTS

MY

CY

MG

CX

D-

-X

20-

Data

MY1M/m₁

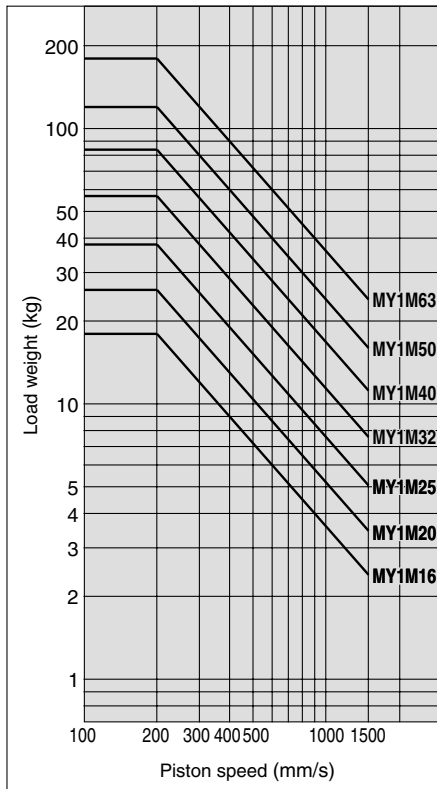

MY1M/m₂

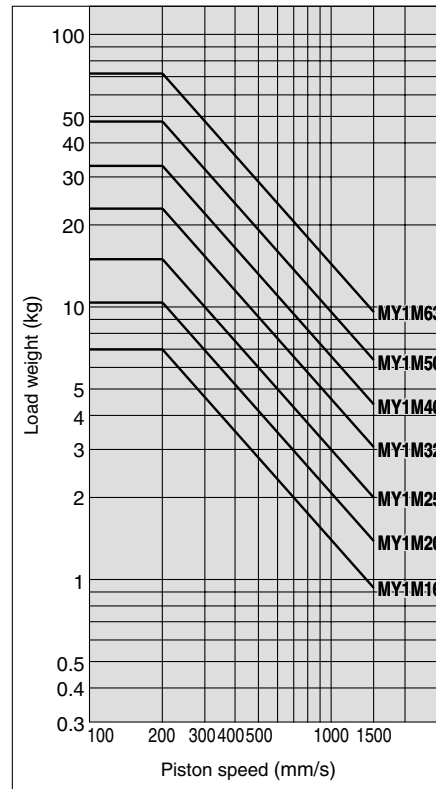

MY1M/m₃

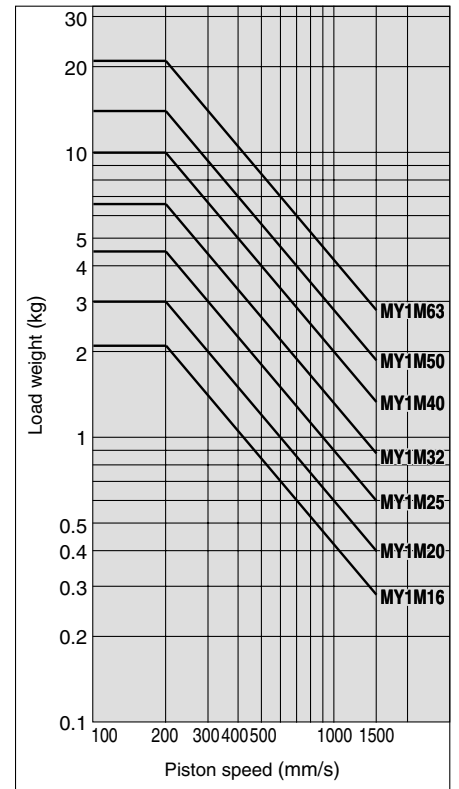

Model Selection

Following are the steps for selecting the most suitable Series MY1M to your application.

Calculation of Guide Load Factor

1. Operating Conditions

- Cylinder MY1M40-500
- Average operating speed v_a ...200 mm/s
- Mounting orientation Horizontal mounting
- Cushion Air cushion ($\delta = 1/100$)

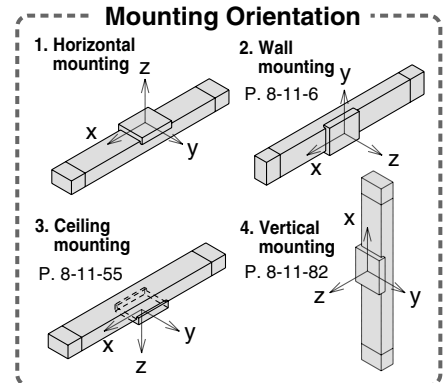
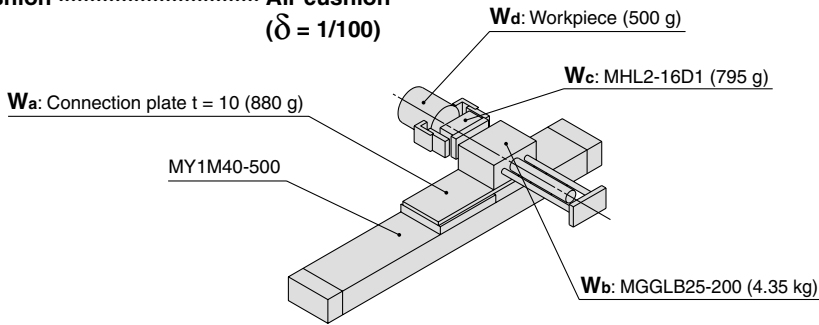

For actual examples of calculation for each orientation, refer to the pages above.

2. Load Blocking

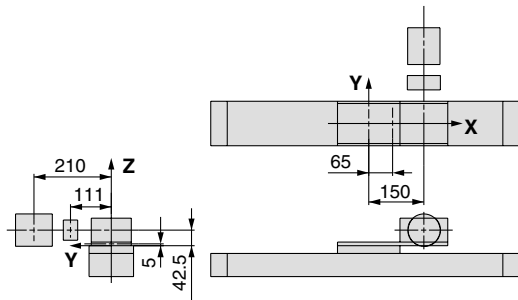

Weight and Center of Gravity for Each Workpiece

Workpiece no. W_n	Weight m_n	Center of gravity		
		X-axis X_n	Y-axis Y_n	Z-axis Z_n
W_a	0.88 kg	65 mm	0 mm	5 mm
W_b	4.35 kg	150 mm	0 mm	42.5 mm
W_c	0.795 kg	150 mm	111 mm	42.5 mm
W_d	0.5 kg	150 mm	210 mm	42.5 mm

$n = a, b, c, d$

3. Composite center of Gravity Calculation

$$m_1 = \sum m_n$$

$$= 0.88 + 4.35 + 0.795 + 0.5 = \mathbf{6.525 \text{ kg}}$$

$$X = \frac{1}{m_1} \times \sum (m_n \times X_n)$$

$$= \frac{1}{6.525} (0.88 \times 65 + 4.35 \times 150 + 0.795 \times 150 + 0.5 \times 150) = \mathbf{138.5 \text{ mm}}$$

$$Y = \frac{1}{m_1} \times \sum (m_n \times Y_n)$$

$$= \frac{1}{6.525} (0.88 \times 0 + 4.35 \times 0 + 0.795 \times 111 + 0.5 \times 210) = \mathbf{29.6 \text{ mm}}$$

$$Z = \frac{1}{m_1} \times \sum (m_n \times Z_n)$$

$$= \frac{1}{6.525} (0.88 \times 5 + 4.35 \times 42.5 + 0.795 \times 42.5 + 0.5 \times 42.5) = \mathbf{37.4 \text{ mm}}$$

4. Calculation of load factor for static load

m_1 : Weight

$$m_{1\text{max}} \text{ (from (1) of graph MY1M/}m_1\text{)} = 84 \text{ (kg)}$$

$$\text{Load factor } \alpha_1 = m_1/m_{1\text{max}} = 6.525/84 = \mathbf{0.08}$$

M_1 : Moment

$$M_{1\text{max}} \text{ (from (2) of graph MY1M/}M_1\text{)} = 59 \text{ (N}\cdot\text{m)}$$

$$M_1 = m_1 \times g \times X = 6.525 \times 9.8 \times 138.5 \times 10^{-3} = 8.86 \text{ (N}\cdot\text{m)}$$

$$\text{Load factor } \alpha_2 = M_1/M_{1\text{max}} = 8.86/59 = \mathbf{0.15}$$

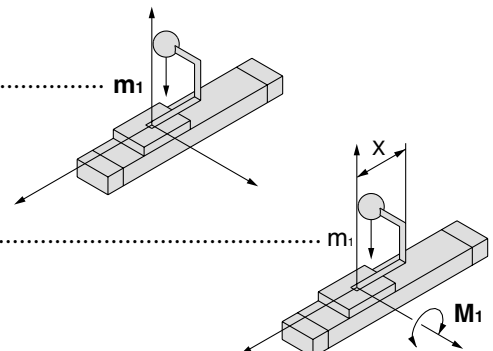

M₂ : Moment

M_{2max} (from (3) of graph MY1M/M₂) = 24 (N·m).....

M₃ = m₁ x g x Y = 6.525 x 9.8 x 29.6 x 10⁻³ = 1.89 (N·m)

Load factor α₃ = M₂/M_{2max} = 1.89/24 = **0.08**

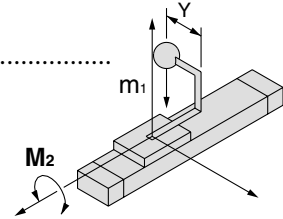

5. Calculation of Load Factor for Dynamic Moment

Equivalent load F_E at impact

F_E = 1.4v_a x δ x m x g = 1.4 x 200 x $\frac{1}{100}$ x 6.525 x 9.8 = 179.1 (N)

M_{1E} : Moment

M_{1Emax} (from (4) of graph MY1M/M₁ where 1.4v_a = 280 mm/s) = 42.1 (N·m).....

M_{1E} = $\frac{1}{3}$ x F_E x Z = $\frac{1}{3}$ x 179.1 x 37.4 x 10⁻³ = 2.23 (N·m)

Load factor α₄ = M_{1E}/M_{1Emax} = 2.23/42.1 = **0.05**

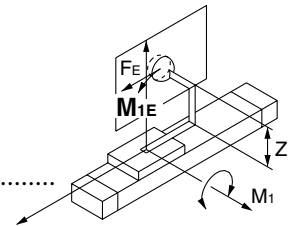

M_{3E} : Moment

M_{3Emax} (from (5) of graph MY1M/M₃ where 1.4v_a = 280 mm/s) = 5.7 (N·m).....

M_{3E} = $\frac{1}{3}$ x F_E x Y = $\frac{1}{3}$ x 179.1 x 29.6 x 10⁻³ = 1.77 (N·m)

Load factor α₅ = M_{3E}/M_{3Emax} = 1.77/5.7 = **0.31**

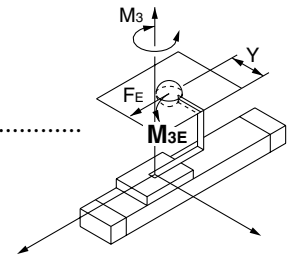

6. Sum and Examination of Guide Load Factors

Σα = α₁ + α₂ + α₃ + α₄ + α₅ = **0.67** ≤ 1

The above calculation is within the allowable value, and therefore the selected model can be used.

Select a shock absorber separately.

In an actual calculation, when the total sum of guide load factors Σα in the formula above is more than 1, consider either decreasing the speed, increasing the bore size, or changing the product series. This calculation can be easily made using the “SMC Pneumatics CAD System”.

Load Weight

MY1M/m₁

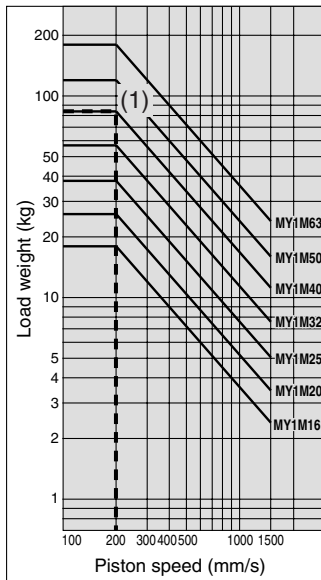

Allowable Moment

MY1M/M₁

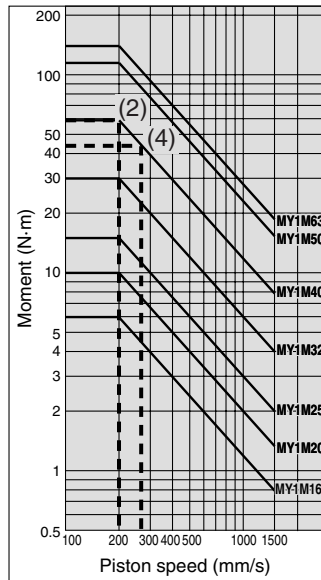

MY1M/M₂

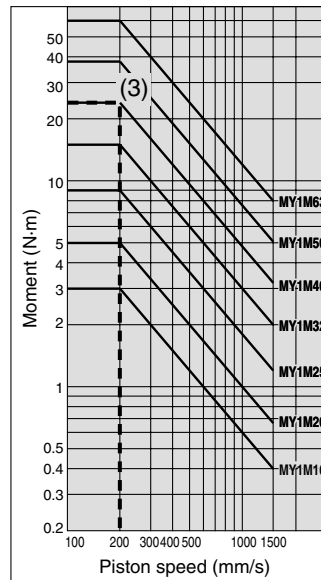

MY1M/M₃

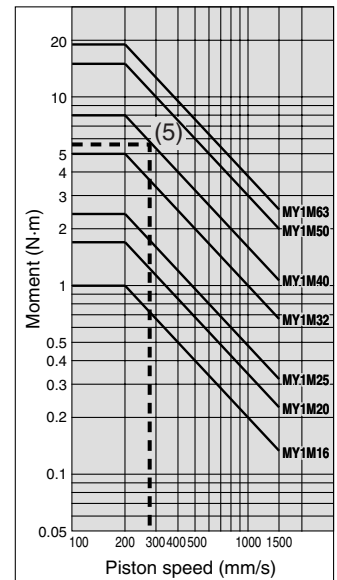

MX	<input type="checkbox"/>
MTS	<input type="checkbox"/>
MY	<input checked="" type="checkbox"/>
CY	<input type="checkbox"/>
MG	<input type="checkbox"/>
CX	<input type="checkbox"/>
D-	<input type="checkbox"/>
-X	<input type="checkbox"/>
20-	<input type="checkbox"/>
Data	<input type="checkbox"/>

Mechanically Jointed Rodless Cylinder Slide Bearing Guide Type



Series MY1M

ø16, ø20, ø25, ø32, ø40, ø50, ø63

How to Order

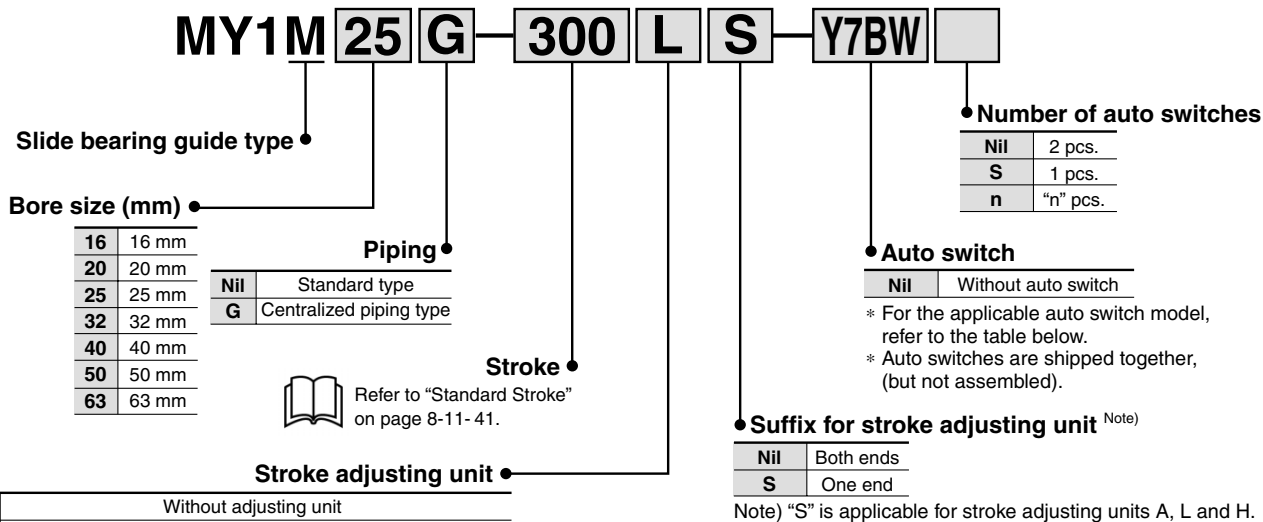

Shock Absorbers for L and H Units

Bore size (mm)	16	20	25	32	40	50	63
L unit	RB0806	RB1007	RB1412			RB2015	
H unit	—	RB1007	RB1412	RB2015			RB2725

Note) MY1M16 is not available with H unit.

Applicable Auto Switch/Refer to page 8-30-1 for further information on auto switches.

For ø16, ø20

Type	Special function	Electrical entry	Indicator light	Wiring (Output)	Load voltage			Auto switch model		Lead wire length (m) *			Pre-wire connector	Applicable load	
					DC	AC	Perpendicular	In-line	0.5 (Nil)	3 (L)	5 (Z)				
Reed switch	—	Grommet	Yes	3-wire (NPN equivalent)	—	5 V	—	A96V	A96	●	●	—	—	IC circuit	—
				2-wire	24 V	12 V	100 V	A93V	A93	●	●	—	—	—	Relay, PLC
Solid state switch	—	Grommet	Yes	3-wire (NPN)	24 V	5 V, 12 V	—	M9NV	M9N	●	●	○	○	IC circuit	Relay, PLC
				3-wire (PNP)				M9PV	M9P	●	●	○	○		
				2-wire				M9BV	M9B	●	●	○	○	—	
				3-wire (NPN)				F9NWV	F9NW	●	●	○	○	IC circuit	
				3-wire (PNP)				F9PWV	F9PW	●	●	○	○	—	
				2-wire				F9BWV	F9BW	●	●	○	○	—	

For ø25, ø32, ø40, ø50, ø63

Type	Special function	Electrical entry	Indicator light	Wiring (Output)	Load voltage			Auto switch model		Lead wire length (m) *			Pre-wire connector	Applicable load	
					DC	AC	Perpendicular	In-line	0.5 (Nil)	3 (L)	5 (Z)				
Reed switch	—	Grommet	Yes	3-wire (NPN equivalent)	—	5 V	—	—	Z76	●	●	—	—	IC circuit	—
				2-wire	24 V	12 V	100 V	—	Z73	●	●	●	—	—	Relay, PLC
Solid state switch	—	Grommet	Yes	3-wire (NPN)	24 V	5 V, 12 V	—	Y69A	Y59A	●	●	○	○	IC circuit	Relay, PLC
				3-wire (PNP)				Y7PV	Y7P	●	●	○	○		
				2-wire				Y69B	Y59B	●	●	○	○	—	
				3-wire (NPN)				Y7NWV	Y7NW	●	●	○	○	IC circuit	
				3-wire (PNP)				Y7PWV	Y7PW	●	●	○	○	—	
				2-wire				Y7BWV	Y7BW	●	●	○	○	—	

* Lead wire length symbols: 0.5 m.....Nil (Example) A93
3 m.....L (Example) Y59BL
5 m.....Z (Example) F9NWZ

* Solid state switches marked with "○" are produced upon receipt of order.

• There are other applicable auto switches than listed above. For details, refer to page 8-11-101.
• For details about auto switches with pre-wire connector, refer to page 8-30-52.

Mechanically Jointed Rodless Cylinder Slide Bearing Guide Type Series MY1M

Specifications

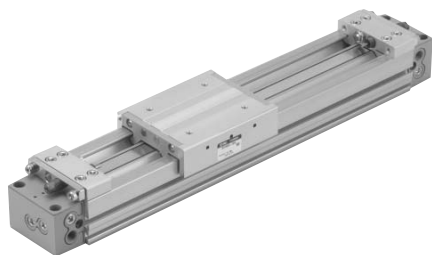

JIS Symbol

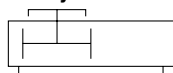

Bore size (mm)		16	20	25	32	40	50	63
Fluid		Air						
Action		Double acting						
Operating pressure range		0.15 to 0.8 MPa						
Proof pressure		1.2 MPa						
Ambient and fluid temperature		5 to 60°C						
Cushion		Air cushion						
Lubrication		Non-lube						
Stroke length tolerance		1000 or less $^{+1.8}_0$ 1001 to 3000 $^{+2.8}_0$	2700 or less $^{+1.8}_0$, 2701 to 5000 $^{+2.8}_0$					
Piping port size	Front/Side port	M5 x 0.8			Rc 1/8	Rc 1/4	Rc 3/8	
	Bottom port	ø4			ø5	ø6	ø8	ø10

Stroke Adjusting Unit Specifications

Bore size (mm)	16			20			25			32			40			50			63		
	Unit symbol			Unit symbol			Unit symbol			Unit symbol			Unit symbol			Unit symbol			Unit symbol		
Configuration	With adjusting bolt	RB 0806 with adjusting bolt	With adjusting bolt	RB 0806 with adjusting bolt	RB 1007 with adjusting bolt	With adjusting bolt	RB 1007 with adjusting bolt	RB 1412 with adjusting bolt	With adjusting bolt	RB 1412 with adjusting bolt	RB 2015 with adjusting bolt	With adjusting bolt	RB 1412 with adjusting bolt	RB 2015 with adjusting bolt	With adjusting bolt	RB 2015 with adjusting bolt	RB 2725 with adjusting bolt	With adjusting bolt	RB 2015 with adjusting bolt	RB 2725 with adjusting bolt	
Fine stroke adjustment range (mm)	0 to -5.6			0 to -6			0 to -11.5			0 to -12			0 to -16			0 to -20			0 to -25		
Stroke adjustment range	When exceeding the stroke fine adjustment range: Utilize a made-to-order specifications "-X416" and "-X417".																				

Shock Absorber Specifications

Model	RB 0806	RB 1007	RB 1412	RB 2015	RB 2725	
	Max. energy absorption (J)	2.9	5.9	19.6	58.8	147
Stroke absorption (mm)	6	7	12	15	25	
Max. collision speed (mm/s)	1500					
Max. operating frequency (cycle/min)	80	70	45	25	10	
Spring force (N)	Extended	1.96	4.22	6.86	8.34	8.83
	Retracted	4.22	6.86	15.98	20.50	20.01
Operating temperature range (°C)	5 to 60					

Piston Speed

Bore size (mm)		16 to 63
Without stroke adjusting unit		100 to 1000 mm/s
Stroke adjusting unit	A unit	100 to 1000 mm/s ⁽¹⁾
	L unit and H unit	100 to 1500 mm/s ⁽²⁾

Note 1) Be aware that when the stroke adjusting range is increased by manipulating the adjusting bolt, the air cushion capacity decreases. Also, when exceeding the air cushion stroke ranges on page 8-11-43, the piston speed should be 100 to 200 mm per second.

Note 2) The piston speed is 100 to 1000 mm/s for centralized piping.

Note 3) Use at a speed within the absorption capacity range. Refer to page 8-11-43.



Made to Order Specifications (For details, refer to page 8-31-1.)

Symbol	Specifications
-XB11	Long stroke
-XC18	NPT finish piping port
-XC67	NBR rubber lining in dust seal band
-X168	Helical insert thread specifications
-X416	Holder mounting bracket I
-X417	Holder mounting bracket II

Standard Stroke

Bore size (mm)	Standard stroke (mm) *	Maximum manufacturable stroke (mm)
16	100, 200, 300, 400, 500, 600, 700	3000
20, 25, 32, 40, 50, 63	800, 900, 1000, 1200, 1400, 1600, 1800, 2000	5000

* Strokes are manufacturable in 1 mm increments, up to the maximum stroke. However, when exceeding a 2000 mm stroke, specify "-XB11" at the end of the model number.

Series MY1M

Theoretical Output

(N)

Bore size (mm)	Piston area (mm ²)	Operating pressure (MPa)						
		0.2	0.3	0.4	0.5	0.6	0.7	0.8
16	200	40	60	80	100	120	140	160
20	314	62	94	125	157	188	219	251
25	490	98	147	196	245	294	343	392
32	804	161	241	322	402	483	563	643
40	1256	251	377	502	628	754	879	1005
50	1962	392	588	784	981	1177	1373	1569
63	3115	623	934	1246	1557	1869	2180	2492

Note) Theoretical output (N) = Pressure (MPa) x Piston area (mm²)

Weight

(kg)

Bore size (mm)	Basic weight	Additional weight per each 50mm of stroke	Side support weight (per set)	Stroke adjusting unit weight (per unit)		
			Type A and B	A unit weight	L unit weight	H unit weight
16	0.67	0.12	0.01	0.03	0.04	—
20	1.11	0.16	0.02	0.04	0.05	0.08
25	1.64	0.24	0.02	0.07	0.11	0.18
32	3.27	0.38	0.04	0.14	0.23	0.39
40	5.88	0.56	0.08	0.25	0.34	0.48
50	10.06	0.77	0.08	0.36	0.51	0.81
63	16.57	1.11	0.17	0.68	0.83	1.08

Calculation: (Example) MY1M25-300A

- Basic weight1.64 kg
- Additional weight0.24/50 st
- Weight of A unit0.07 kg
- Cylinder stroke.....300 st

$$1.64 + 0.24 \times 300 \div 50 + 0.07 \times 2 \cong 3.22 \text{ kg}$$

Option

Stroke Adjusting Unit Part No.

Bore (mm)	16	20	25	32
A unit	MYM-A16A	MYM-A20A	MYM-A25A	MYM-A32A
L unit	MYM-A16L	MYM-A20L	MYM-A25L	MYM-A32L
H unit	—	MYM-A20H	MYM-A25H	MYM-A32H

Bore (mm)	40	50	63
A unit	MYM-A40A	MYM-A50A	MYM-A63A
L unit	MYM-A40L	MYM-A50L	MYM-A63L
H unit	MYM-A40H	MYM-A50H	MYM-A63H

Side Support Part No.

Bore (mm)	16	20	25	32
Side support A	MY-S16A	MY-S20A	MY-S25A	MY-S32A
Side support B	MY-S16B	MY-S20B	MY-S25B	MY-S32B

Bore (mm)	40	50	63
Side support A	MY-S40A	MY-S63A	
Side support B	MY-S40B	MY-S63B	

For details about dimensions, etc., refer to page 8-11-49.

Cushion Capacity

Cushion Selection

<Air cushion>

Air cushions are a standard feature on mechanically jointed rodless cylinders. The air cushion mechanism is incorporated to prevent excessive impact of the piston at the stroke end during high speed operation. The purpose of air cushion, thus, is not to decelerate the piston near the stroke end. The ranges of load and speed that air cushions can absorb are within the air cushion limit lines shown in the graphs.

<Stroke adjusting unit with shock absorber>

Use this unit when operating with a load or speed exceeding the air cushion limit line, or when cushioning is required outside of the effective air cushion stroke range due to stroke adjustment.

<L unit>

Use this unit when the cylinder stroke is outside of the effective air cushion range even if the load and speed are within the air cushion limit line, or when the cylinder is operated in a load and speed range above the air cushion limit line or below the L unit limit line.

<H unit>

Use this unit when the cylinder is operated in a load and speed range above the L unit limit line and below the H unit limit line.

⚠ Caution

1. Refer to the figure below when using the adjusting bolt to perform stroke adjustment.

When the effective stroke of the shock absorber decreases as a result of stroke adjustment, the absorption capacity decreases dramatically. Secure the adjusting bolt at the position where it protrudes approximately 0.5 mm from the shock absorber.

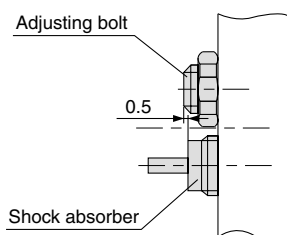

2. Do not use a shock absorber together with air cushion.

Air Cushion Stroke

Bore size (mm)	Cushion stroke
16	12
20	15
25	15
32	19
40	24
50	30
63	37

Absorption Capacity of Air Cushion and Stroke Adjusting Units

MY1M16

Horizontal collision: P = 0.5 MPa

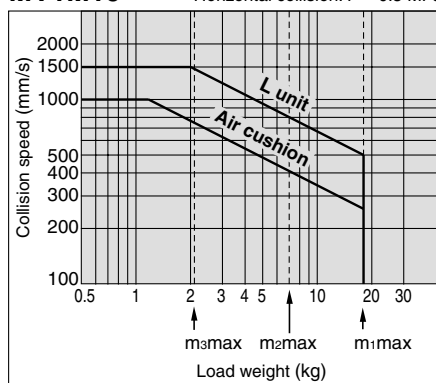

MY1M32

Horizontal collision: P = 0.5 MPa

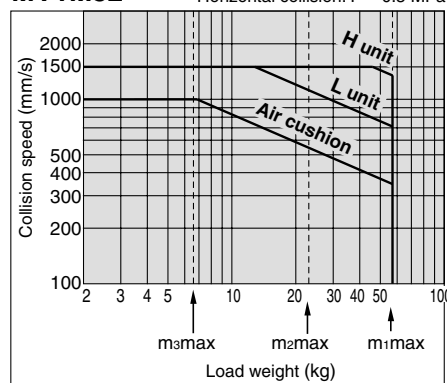

MY1M20

Horizontal collision: P = 0.5 MPa

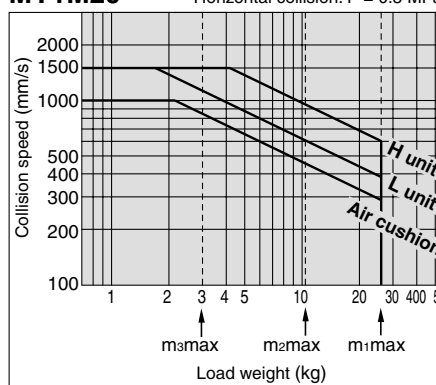

MY1M40

Horizontal collision: P = 0.5 MPa

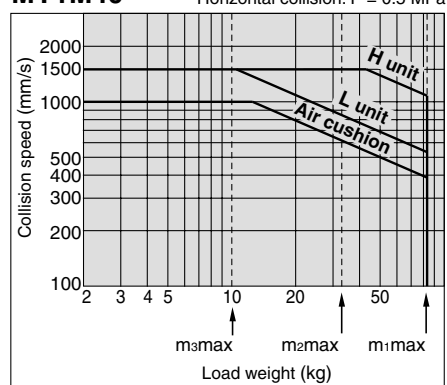

MY1M25

Horizontal collision: P = 0.5 MPa

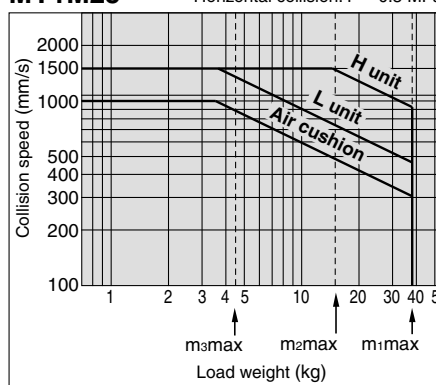

MY1M50

Horizontal collision: P = 0.5 MPa

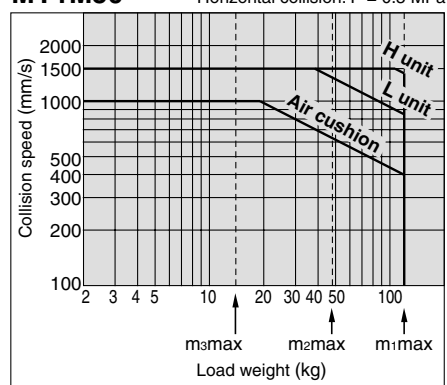

MY1M63

Horizontal collision: P = 0.5 MPa

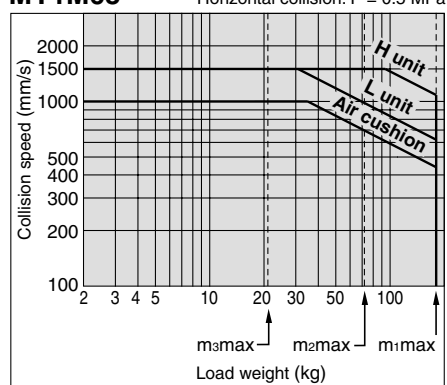

MX

MTS

MY

CY

MG

CX

D-

-X

20-

Data

Series MY1M

Cushion Capacity

Tightening Torque for Stroke Adjusting Unit Holding Bolts (N·m)

Bore size (mm)	Unit	Tightening torque
16	A	0.6
	L	
20	A	1.5
	H	
25	A	3.0
	L	5.0
	H	
32	A	5.0
	L	12
	H	
40	A	12
	L	
	H	
50	A	12
	L	
	H	
63	A	24
	L	
	H	

Tightening Torque for Stroke Adjusting Unit Lock Plate Holding Bolts (N·m)

Bore size (mm)	Unit	Tightening torque
25	L	1.2
	H	3.3
32	L	3.3
	H	10
40	L	3.3
	H	10

Calculation of Absorbed Energy for Stroke Adjusting Unit with Shock Absorber (N·m)

Type of impact	Horizontal collision	Vertical (Downward)	Vertical (Upward)
Kinetic energy E ₁		$\frac{1}{2} m v^2$	
Thrust energy E ₂	F·S	F·S + m·g·s	F·S - m·g·s
Absorbed energy E	$E_1 + E_2$		

Symbol

v: Speed of impact object (m/s)

F: Cylinder thrust (N)

s: Shock absorber stroke (m)

m: Weight of impact object (kg)

g: Gravitational acceleration (9.8 m/s²)

Note) The speed of the impact object is measured at the time of impact with the shock absorber.

⚠ Precautions

Be sure to read before handling. For Safety Instructions and Actuator Precautions, refer to pages 8-34-3 to 8-34-6.

⚠ Caution

Use caution not to get your hands caught in the unit.

- When using a product with stroke adjusting unit, the space between the slide table (slider) and the stroke adjusting unit becomes narrow at the stroke end, causing a danger of hands getting caught. Install a protective cover to prevent direct contact with the human body.

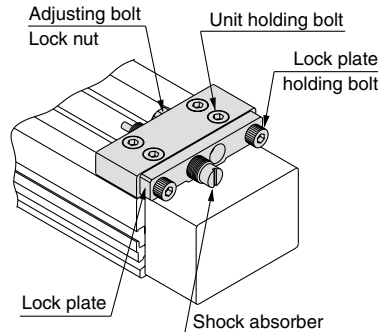

<Fastening of unit>

The unit can be secured by evenly tightening the four unit holding bolts.

⚠ Caution

Do not operate with the stroke adjusting unit fixed in an intermediate position.

When the stroke adjusting unit is fixed in an intermediate position, slippage can occur depending on the amount of energy released at the time of an impact. In such cases, the use of the adjusting bolt mounting brackets, available per made-to-order specifications -X416 and -X417, is recommended.

For other lengths, please consult with SMC (Refer to "Tightening Torque for Stroke Adjusting Unit Holding Bolts".)

<Stroke adjustment with adjusting bolt>

Loosen the adjusting bolt lock nut, and adjust the stroke from the lock plate side using a hexagon wrench. Retighten the lock nut.

<Stroke adjustment with shock absorber>

Loosen the two lock plate holding bolts, turn the shock absorber and adjust the stroke. Then, uniformly tighten the lock plate holding bolts to secure the shock absorber.

Take care not to over-tighten the holding bolts. (Except $\varnothing 16$, $\varnothing 20$, $\varnothing 50$, $\varnothing 63$) (Refer to "Tightening Torque for Stroke Adjusting Unit Lock Plate Holding Bolts".)

Note) Although the lock plate may slightly bend due to tightening of the lock plate holding bolt, this does not affect the shock absorber and locking function.

Mechanically Jointed Rodless Cylinder Slide Bearing Guide Type Series MY1M

Standard Type/Centralized Piping Type $\phi 16, \phi 20$

Refer to page 8-11-9 regarding centralized piping port variations.

MY1M16□/20□ — Stroke

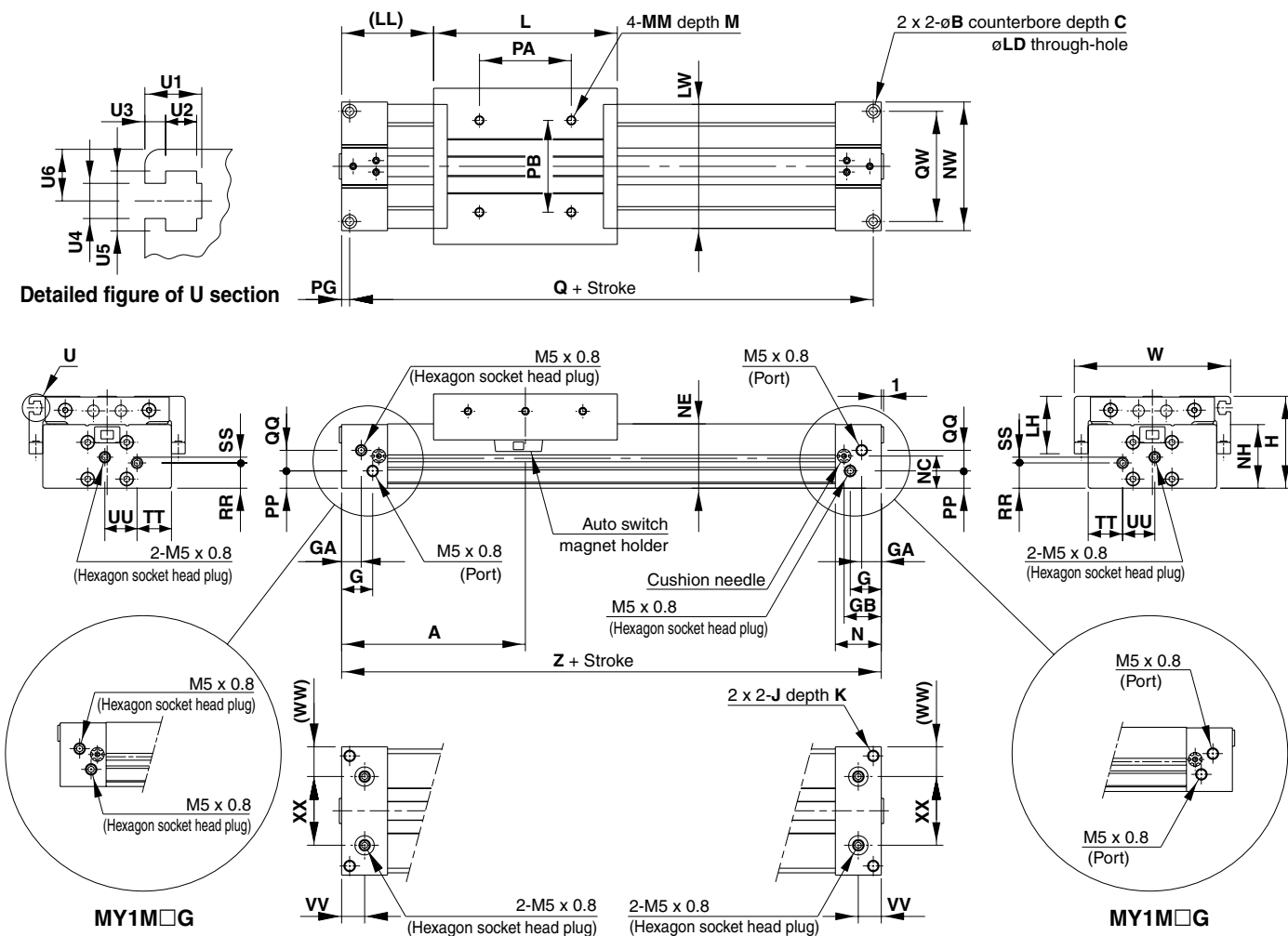

- MX□
- MTS
- MY□**
- CY□
- MG□
- CX□
- D-
- X
- 20-
- Data

Model	A	B	C	G	GA	GB	H	J	K	L	LD	LH	LL	LW	M	MM	N	NC	NE	NH	NW	PA
MY1M16□	80	6	3.5	13.5	8.5	16.2	40	M5 x 0.8	10	80	3.6	22.5	40	54	6	M4 x 0.7	20	14	28	27.7	56	40
MY1M20□	100	7.5	4.5	12.5	12.5	20	46	M6 x 1	12	100	4.8	23	50	58	7.5	M5 x 0.8	25	17	34	33.7	60	50

Model	PB	PG	PP	Q	QQ	QW	RR	SS	TT	UU	VV	W	WW	XX	Z
MY1M16□	40	3.5	7.5	153	9	48	11	2.5	15	14	10	68	13	30	160
MY1M20□	40	4.5	11.5	191	10	45	14.5	5	18	12	12.5	72	14	32	200

Model	U1	U2	U3	U4	U5	U6
MY1M16□	5.5	3	2	3.4	5.8	5
MY1M20□	5.5	3	2	3.4	5.8	5.5

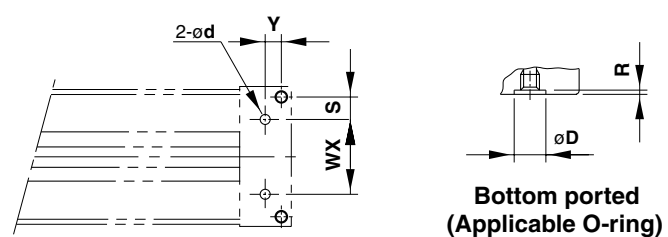

Model	WX	Y	S	d	D	R	Applicable O-ring
MY1M16□	30	6.5	9	4	8.4	1.1	C6
MY1M20□	32	8	6.5	4	8.4	1.1	

(Machine the mounting side to the dimensions below.)

Series MY1M

Standard Type/Centralized Piping Type $\phi 25, \phi 32, \phi 40$ Refer to page 8-11-9 regarding centralized piping port variations.

MY1M25□/32□/40□ — Stroke

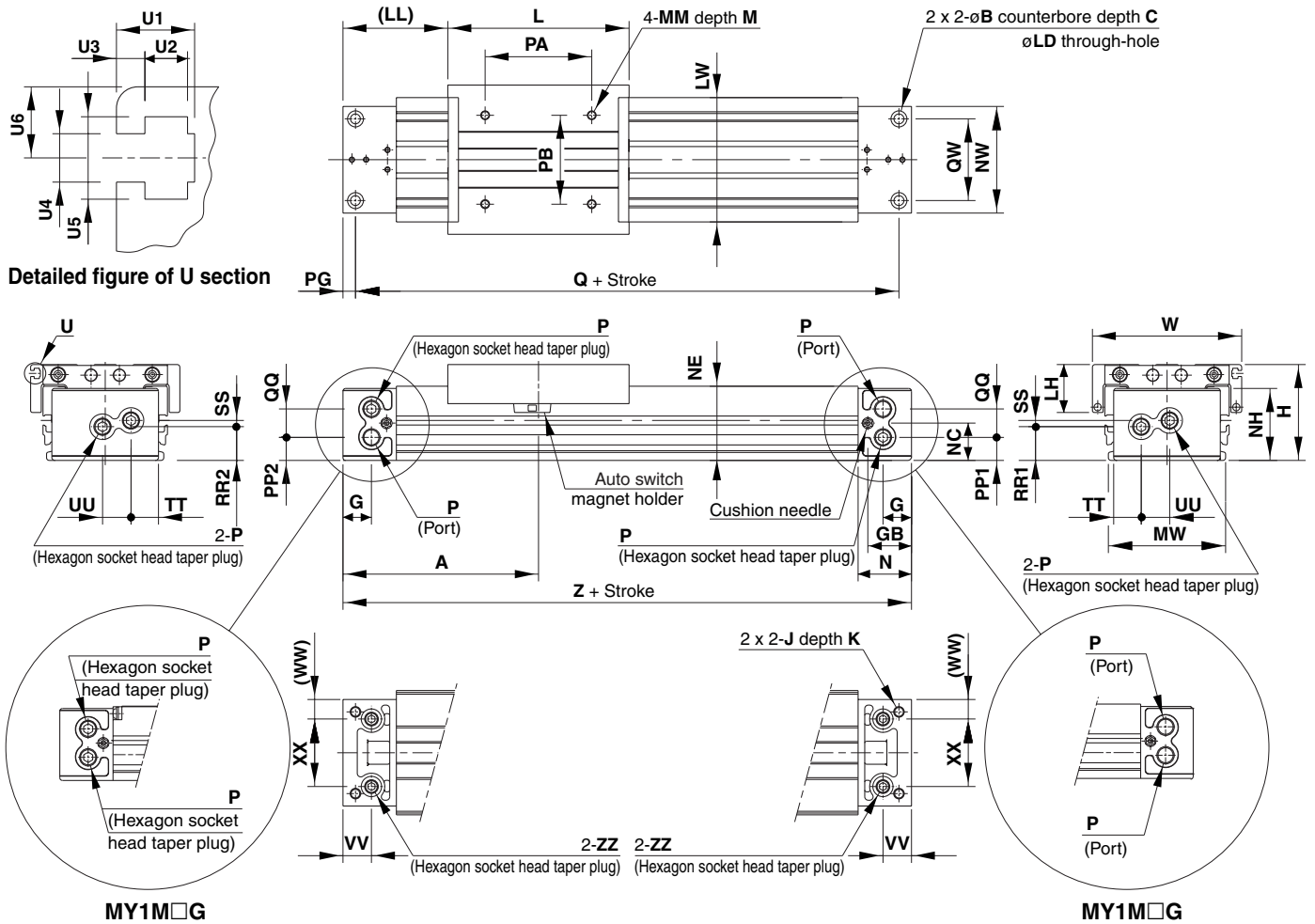

Model	A	B	C	G	GB	H	J	K	L	LD	LH	LL	LW	M	MM	MW	N	NC	NE	NH	NW	P	PA
MY1M25□	110	9	5.5	17	24.5	54	M6 x 1	9.5	102	5.6	27	59	70	10	M5 x 0.8	66	30	21	41.8	40.5	60	Rc 1/8	60
MY1M32□	140	11	6.5	19	30	68	M8 x 1.25	16	132	6.8	35	74	88	13	M6 x 1	80	37	26	52.3	50	74	Rc 1/8	80
MY1M40□	170	14	8.5	23	36.5	84	M10 x 1.5	15	162	8.6	38	89	104	13	M6 x 1	96	45	32	65.3	63.5	94	Rc 1/4	100

"P" indicates cylinder supply ports.

Detailed Dimensions of U Section

Model	PB	PG	PP1	PP2	Q	QQ	QW	RR1	RR2	SS	TT	UU	VV	W	WW	XX	Z	ZZ
MY1M25□	50	7	12.7	12.7	206	16	46	18.9	17.9	4.1	15.5	16	16	84	11	38	220	Rc 1/16
MY1M32□	60	8	15.5	18.5	264	16	60	22	24	4	21	16	19	102	13	48	280	Rc 1/16
MY1M40□	80	9	17.5	20	322	26	72	25.5	29	9	26	21	23	118	20	54	340	Rc 1/8

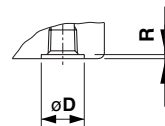
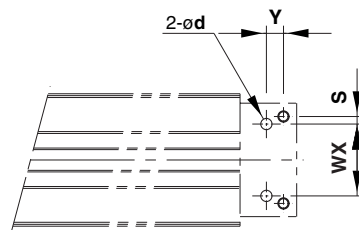

Bottom ported (ZZ)
(Applicable O-ring)

Hole Size for Centralized Piping on the Bottom

Model	WX	Y	S	d	D	R	Applicable O-ring
MY1M25□	38	9	4	6	11.4	1.1	C9
MY1M32□	48	11	6	6	11.4	1.1	
MY1M40□	54	14	9	8	13.4	1.1	C11.2

(Machine the mounting side to the dimensions below.)

Mechanically Jointed Rodless Cylinder Slide Bearing Guide Type Series MY1M

Standard Type/Centralized Piping Type $\phi 50, \phi 63$

Refer to page 8-11-9 regarding centralized piping port variations.

MY1M50□/60□ — Stroke

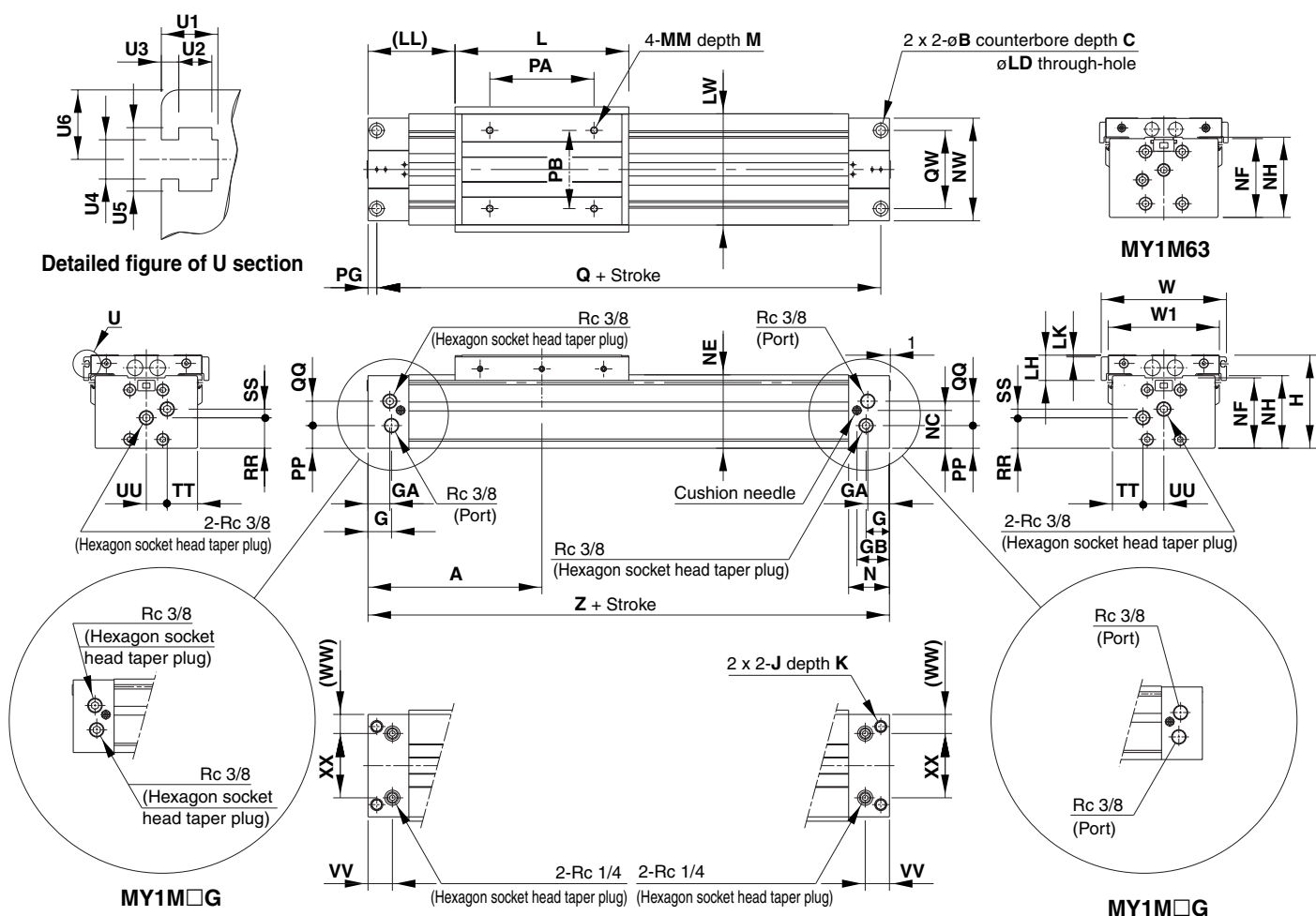

- MX□
- MTS
- MY□
- CY□
- MG□
- CX□
- D-
- X
- 20-
- Data

Model	A	B	C	G	GA	GB	H	J	K	L	LD	LH	LK	LL	LW	M	MM	N	NC	NE	NF	NH	NW	PA
MY1M50□	200	17	10.5	27	25	37.5	107	M14 x 2	28	200	11	29	2	100	128	15	M8 x 1.25	47	43.5	84.5	81	83.5	118	120
MY1M63□	230	19	12.5	29.5	27.5	39.5	130	M16 x 2	32	230	13.5	32.5	5.5	115	152	16	M10 x 1.5	50	56	104	103	105	142	140

Model	PB	PG	PP	Q	QQ	QW	RR	SS	TT	UU	VV	W	W1	WW	XX	Z
MY1M50□	90	10	26	380	28	90	35	10	35	24	28	144	128	22	74	400
MY1M63□	110	12	42	436	30	110	49	13	43	28	30	168	152	25	92	460

Detailed Dimensions of U Section

Model	U1	U2	U3	U4	U5	U6
MY1M50□	6.5	3.8	2	4.5	7.3	8
MY1M63□	8.5	5	2.5	5.5	8.4	8

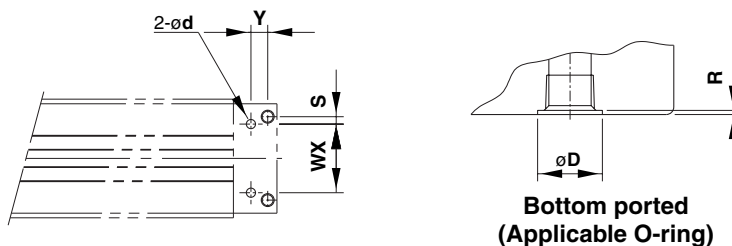

Hole Size for Centralized Piping on the Bottom

Model	WX	Y	S	d	D	R	Applicable O-ring
MY1M50□	74	18	8	10	17.5	1.1	C15
MY1M63□	92	18	9	10	17.5	1.1	

(Machine the mounting side to the dimensions below.)



Series MY1M

Stroke Adjusting Unit

With adjusting bolt

MY1M Bore size — Stroke A

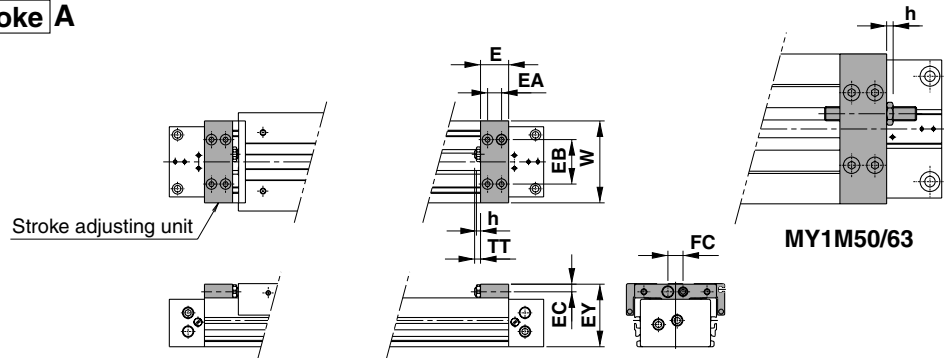

Applicable bore size	E	EA	EB	EC	EY	FC	h	TT	W
MY1M16	14.6	7	30	5.8	39.5	14	3.6	5.4 (Max. 11)	58
MY1M20	20	10	32	5.8	45.5	14	3.6	5 (Max. 11)	58
MY1M25	24	12	38	6.5	53.5	13	3.5	5 (Max. 16.5)	70
MY1M32	29	14	50	8.5	67	17	4.5	8 (Max. 20)	88
MY1M40	35	17	57	10	83	17	4.5	9 (Max. 25)	104
MY1M50	40	20	66	14	106	26	5.5	13 (Max. 33)	128
MY1M63	52	26	77	14	129	31	5.5	13 (Max. 38)	152

With low load shock absorber + Adjusting bolt

MY1M Bore size — Stroke L

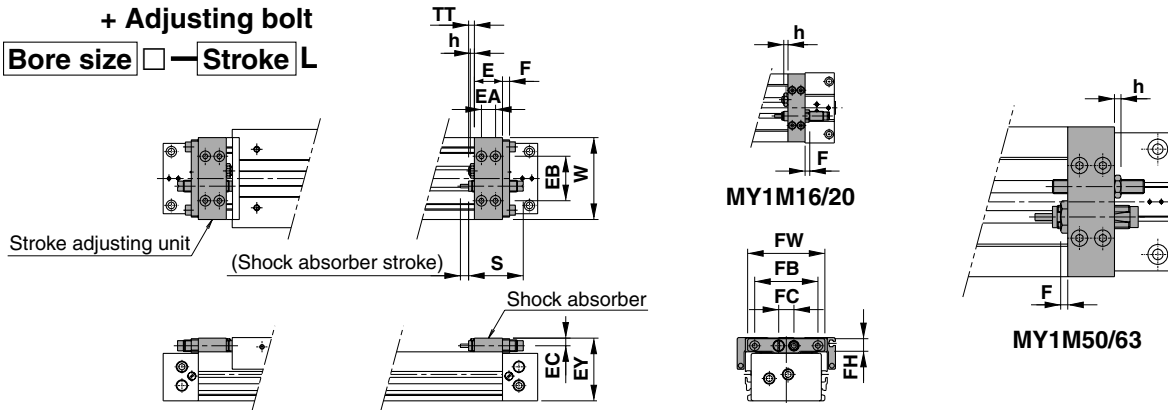

Applicable bore size	E	EA	EB	EC	EY	F	FB	FC	FH	FW	h	S	T	TT	W	Shock absorber model
MY1M16	14.6	7	30	5.8	39.5	4	—	14	—	—	3.6	40.8	6	5.4 (Max. 11)	58	RB0806
MY1M20	20	10	32	5.8	45.5	4	—	14	—	—	3.6	40.8	6	5 (Max. 11)	58	RB0806
MY1M25	24	12	38	6.5	53.5	6	54	13	13	66	3.5	46.7	7	5 (Max. 16.5)	70	RB1007
MY1M32	29	14	50	8.5	67	6	67	17	16	80	4.5	67.3	12	8 (Max. 20)	88	RB1412
MY1M40	35	17	57	10	83	6	78	17	17.5	91	4.5	67.3	12	9 (Max. 25)	104	RB1412
MY1M50	40	20	66	14	106	6	—	26	—	—	5.5	73.2	15	13 (Max. 33)	128	RB2015
MY1M63	52	26	77	14	129	6	—	31	—	—	5.5	73.2	15	13 (Max. 38)	152	RB2015

With high load shock absorber + Adjusting bolt

MY1M Bore size — Stroke H

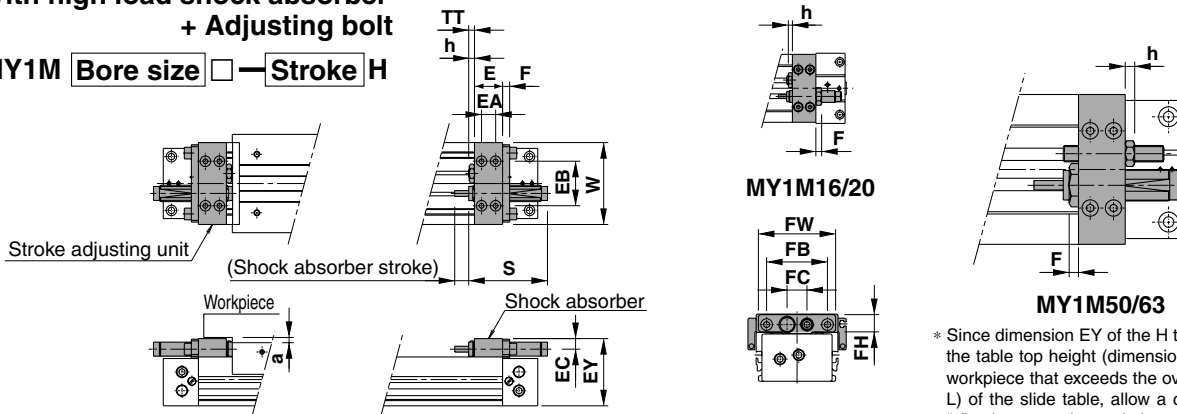

* Since dimension EY of the H type unit is greater than the table top height (dimension H), when mounting a workpiece that exceeds the overall length (dimension L) of the slide table, allow a clearance of dimension "a" or larger on the workpiece side.

Applicable bore size	E	EA	EB	EC	EY	F	FB	FC	FH	FW	h	S	T	TT	W	Shock absorber model	a
MY1M20	20	10	32	7.7	50	5	—	14	—	—	3.5	46.7	7	5 (Max. 11)	58	RB1007	5
MY1M25	24	12	38	9	57.5	6	52	17	16	66	4.5	67.3	12	5 (Max. 16.5)	70	RB1412	4.5
MY1M32	29	14	50	11.5	73	8	67	22	22	82	5.5	73.2	15	8 (Max. 20)	88	RB2015	6
MY1M40	35	17	57	12	87	8	78	22	22	95	5.5	73.2	15	9 (Max. 25)	104	RB2015	4
MY1M50	40	20	66	18.5	115	8	—	30	—	—	11	99	25	13 (Max. 33)	128	RB2725	9
MY1M63	52	26	77	19	138.5	8	—	35	—	—	11	99	25	13 (Max. 38)	152	RB2725	9.5

Side Support

Side support A MY-S□A

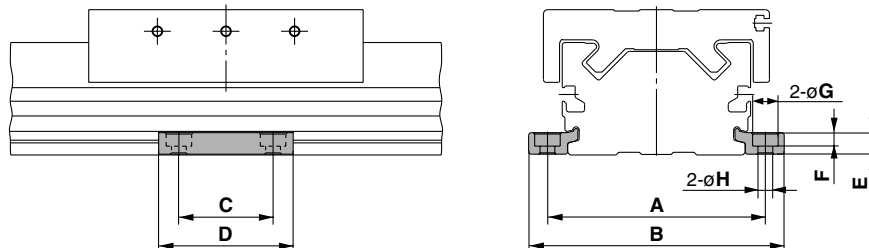

Side support B MY-S□B

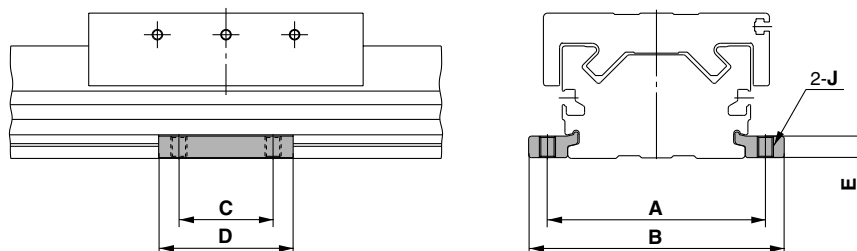

(mm)

Model	Applicable bore size	A	B	C	D	E	F	G	H	J
MY-S16 ^A _B	MY1M16	61	71.6	15	26	4.9	3	6.5	3.4	M4 x 0.7
MY-S20 ^A _B	MY1M20	67	79.6	25	38	6.4	4	8	4.5	M5 x 0.8
MY-S25 ^A _B	MY1M25	81	95	35	50	8	5	9.5	5.5	M6 x 1
MY-S32 ^A _B	MY1M32	100	118	45	64	11.7	6	11	6.6	M8 x 1.25
MY-S40 ^A _B	MY1M40	120	142	55	80	14.8	8.5	14	9	M10 x 1.5
	MY1M50	142	164							
MY-S63 ^A _B	MY1M63	172	202	70	100	18.3	10.5	17.5	11.5	M12 x 1.75

Guide for Side Support Application

For long stroke operation, the cylinder tube may be deflected depending on its own weight and the load weight. In such a case, use a side support in the middle section. The spacing (ℓ) of the support must be no more than the values shown in the graph on the right.

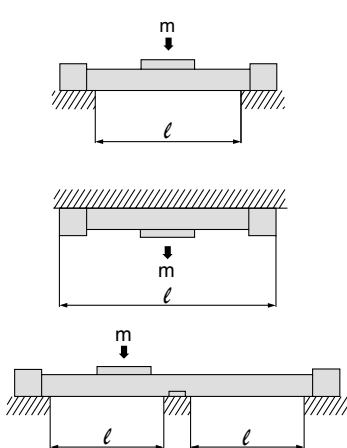

⚠ Caution

1. If the cylinder mounting surfaces are not measured accurately, using a side support may cause poor operation. Therefore, be sure to level the cylinder tube when mounting. Also, for long stroke operation involving vibration and impact, use of a side support is recommended even if the spacing value is within the allowable limits shown in the graph.
2. Support brackets are not for mounting; use them solely for providing support.

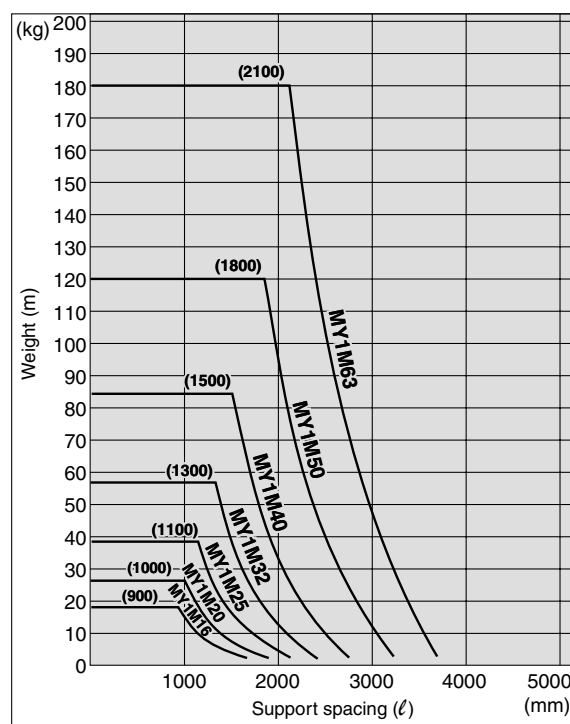

MX□
MTS
MY□
CY□
MG□
CX□
D-
-X
20-
Data

Series MY1M

Construction: $\varnothing 16$ to $\varnothing 63$

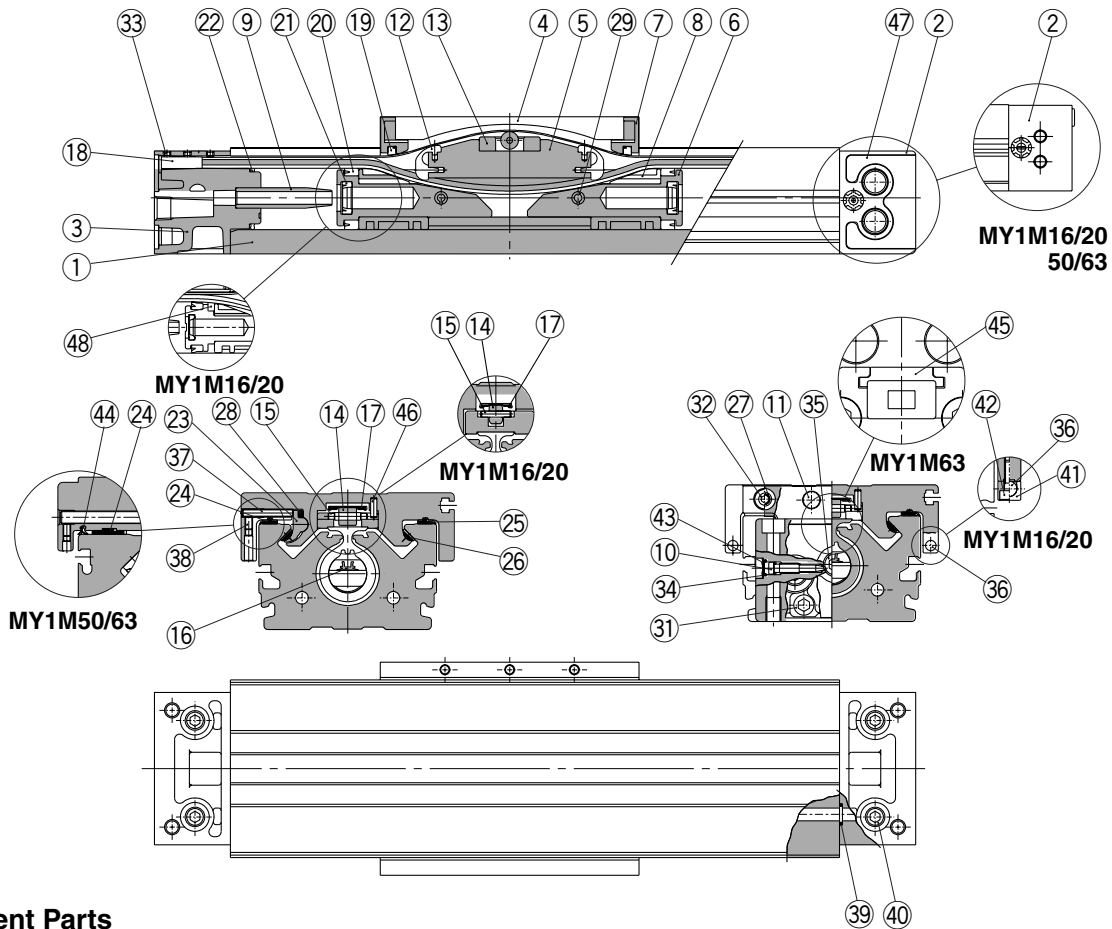

Component Parts

No.	Description	Material	Note
①	Cylinder tube	Aluminum alloy	Hard anodized
②	Head cover WR	Aluminum alloy	Painted
③	Head cover WL	Aluminum alloy	Painted
④	Slide table	Aluminum alloy	Hard anodized
⑤	Piston yoke	Aluminum alloy	Chromated
⑥	Piston	Aluminum alloy	Chromated
⑦	End cover	Special resin	
⑧	Wear ring	Special resin	
⑨	Cushion ring	Brass	
⑩	Cushion needle	Rolled steel	Nickel plated
⑪	Stopper	Carbon steel	Nickel plated
⑫	Belt separator	Special resin	
⑬	Coupler	Sintered iron material	
⑭	Guide roller	Special resin	
⑮	Guide roller shaft	Stainless steel	
⑱	Belt clamp	Special resin	
⑳	Adjusting arm	Aluminum alloy	Hard anodized
㉑	Bearing R	Special resin	
㉒	Bearing L	Special resin	
㉓	Bearing S	Special resin	

No.	Description	Material	Note
㉔	Spacer	Stainless steel	
㉕	Backup spring	Stainless steel	
㉖	Spring pin	Carbon tool steel	Black zinc chromated
㉗	Hexagon socket head cap screw	Chromium molybdenum steel	Nickel plated
㉘	Hexagon socket button head screw	Chromium molybdenum steel	Nickel plated
㉙	Hexagon socket head set screw	Chromium molybdenum steel	Black zinc chromated/Nickel plated
㉚	Hexagon socket head taper plug	Carbon steel	Nickel plated
㉛	Magnet	Rare earth magnet	
㉜	Hexagon socket head set screw	Chromium molybdenum steel	Black zinc chromated
㉝	Hexagon socket head set screw	Chromium molybdenum steel	Black zinc chromated
㉞	Hexagon socket head taper plug	Carbon steel	Nickel plated
㉟	Magnet holder	Special resin	($\varnothing 16$, $\varnothing 20$)
㊱	Hexagon socket head cap screw	Chromium molybdenum steel	Nickel plated
㊲	Type CR retaining ring	Spring steel	
㊳	Head plate	Aluminum alloy	Hard anodized ($\varnothing 63$)
㊴	Parallel pin	Stainless steel	Hard anodized (Except $\varnothing 16$, $\varnothing 20$)
㊵	Port cover	Special resin	($\varnothing 25$ to $\varnothing 40$)
㊶	Felt B	Felt	($\varnothing 16$, $\varnothing 20$)

Seal List

No.	Description	Material	Qty.	MY1M16	MY1M20	MY1M25	MY1M32	MY1M40	MY1M50	MY1M63
⑯	Seal belt	Special resin	1	MY16-16A-Stroke	MY20-16A-Stroke	MY25-16A-Stroke	MY32-16A-Stroke	MY40-16A-Stroke	MY50-16A-Stroke	MY63-16A-Stroke
⑰	Dust seal band	Stainless steel	1	MY16-16B-Stroke	MY20-16B-Stroke	MY25-16B-Stroke	MY32-16B-Stroke	MY40-16B-Stroke	MY50-16B-Stroke	MY63-16B-Stroke
⑲	Scraper	NBR	2	MYM16-15AK0500	MYM20-15AK0501	MYM25-15AA5903	MYM32-15AA5904	MYM40-15AA5905	MYM50-15AK0502	MYM63-15AK0503
⑳	Piston seal	NBR	2	GM Y16	GM Y20	GM Y25	GM Y32	GM Y40	GM Y50	GM Y63
㉑	Cushion seal	NBR	2	MYB16-15-A7163	MYB20-15-A7164	RCS-8	RCS-10	RCS-12	MC-16	MC-20
㉒	Tube gasket	NBR	2	P12	P16	TMY-25	TMY-32	TMY-40	P44	P53
㉓	O-ring	NBR	2	$\varnothing 4 \times \varnothing 1.8 \times \varnothing 1.1$	$\varnothing 5.1 \times \varnothing 3 \times \varnothing 1.05$	$\varnothing 5.1 \times \varnothing 3 \times \varnothing 1.05$	$\varnothing 7.15 \times \varnothing 3.75 \times \varnothing 1.7$	$\varnothing 8.3 \times \varnothing 4.5 \times \varnothing 1.9$	C-4	C-4
㉔	O-ring	NBR	4	$\varnothing 7 \times \varnothing 4 \times \varnothing 1.5$	$\varnothing 7 \times \varnothing 4 \times \varnothing 1.5$	C-6	C-7	C-9	C-11.2	C-14
㉕	Side scraper	Special resin	2	—	—	—	—	—	MYM50-15CK0502B	MYM63-15CK0503B

Note) Two types of dust seal band are available. Verify the type to use, since the part number varies depending on the treatment of the hexagon socket head set screw ㉓.

(A) Black zinc chromated → MY□□-16B-Stroke, (B) Nickel plated → MY□□-16BW-Stroke

Series MY1C

Cam Follower Guide Type
ø16, ø20, ø25, ø32, ø40, ø50, ø63

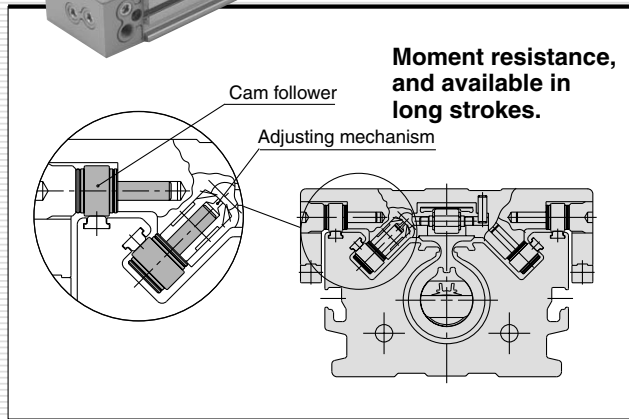
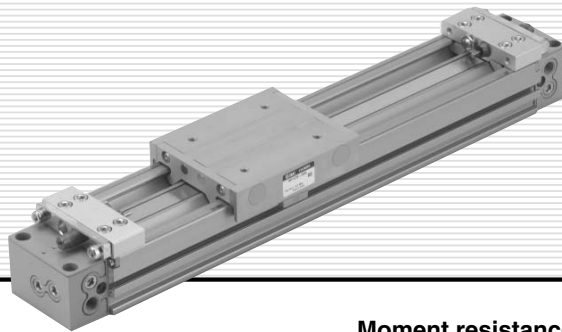

MX□

MTS

MY□

CY□

MG□

CX□

D-

-X

20-

Data

Series MY1C

Before Operation

Maximum Allowable Moment/Maximum Load Weight

Model	Bore size (mm)	Maximum allowable moment (N-m)			Maximum load weight (kg)		
		M ₁	M ₂	M ₃	m ₁	m ₂	m ₃
MY1C	16	6.0	3.0	2.0	18	7	2.1
	20	10	5.0	3.0	25	10	3
	25	15	8.5	5.0	35	14	4.2
	32	30	14	10	49	21	6
	40	60	23	20	68	30	8.2
	50	115	35	35	93	42	11.5
	63	150	50	50	130	60	16

The above values are the maximum allowable values for moment and load. Refer to each graph regarding the maximum allowable moment and maximum allowable load for a particular piston speed.

Maximum Allowable Moment

Select the moment from within the range of operating limits shown in the graphs. Note that the maximum allowable load value may sometimes be exceeded even within the operating limits shown in the graphs. Therefore, also check the allowable load for the selected conditions.

Load weight (kg)

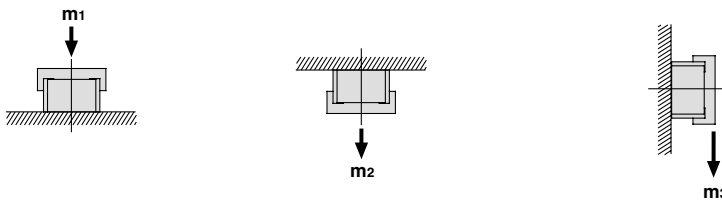

Moment (N-m)

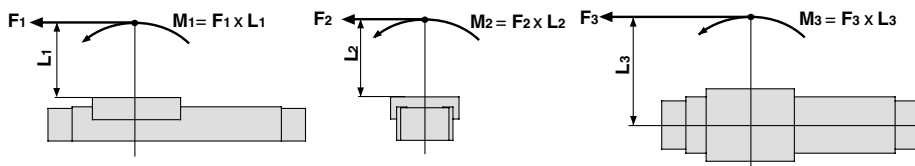

<Calculation of guide load factor>

- Maximum allowable load (1), static moment (2), and dynamic moment (3) (at the time of impact with stopper) must be examined for the selection calculations.
 - * To evaluate, use \bar{v} (average speed) for (1) and (2), and v (collision speed $v = 1.4\bar{v}$) for (3). Calculate m_{max} for (1) from the maximum allowable load graph (m_1, m_2, m_3) and M_{max} for (2) and (3) from the maximum allowable moment graph (M_1, M_2, M_3).

$$\text{Sum of guide load factors } \Sigma \alpha = \frac{\text{Load weight [m]}}{\text{Maximum allowable load [m}_{max}\text{]}} + \frac{\text{Static moment [M]}^{(1)}}{\text{Allowable static moment [M}_{max}\text{]}} + \frac{\text{Dynamic moment [M}_E\text{]}^{(2)}}{\text{Allowable dynamic moment [M}_{E,max}\text{]}} \leq 1$$

Note 1) Moment caused by the load, etc., with cylinder in resting condition.

Note 2) Moment caused by the impact load equivalent at the stroke end (at the time of impact with stopper).

Note 3) Depending on the shape of the workpiece, multiple moments may occur. When this happens, the sum of the load factors ($\Sigma \alpha$) is the total of all such moments.

2. Reference formula [Dynamic moment at impact]

Use the following formulae to calculate dynamic moment when taking stopper impact into consideration.

m: Load weight (kg)

F: Load (N)

F_E: Load equivalent to impact (at impact with stopper) (N)

\bar{v} : Average speed (mm/s)

M: Static moment (N-m)

$$v = 1.4\bar{v} \text{ (mm/s)} \quad F_E = 1.4\bar{v} \cdot \delta \cdot m \cdot g \quad \text{Note 4)}$$

$$\therefore M_E = \frac{1}{3} \cdot F_E \cdot L_1 = 4.57\bar{v} \delta m L_1 \text{ (N-m)} \quad \text{Note 5)}$$

v : Collision speed (mm/s)

L₁: Distance to the load's center of gravity (m)

M_E: Dynamic moment (N-m)

δ : Damper coefficient At collision: $v = 1.4\bar{v}$

With rubber bumper = 4/100

(MY1B10, MY1H10)

With air cushion = 1/100

With shock absorber = 1/100

g: Gravitational acceleration (9.8 m/s²)

Note 4) $1.4\bar{v}\delta$ is a dimensionless coefficient for calculating impact force.

Note 5) Average load coefficient ($= \frac{1}{3}$): This coefficient is for averaging the maximum load moment at the time of stopper impact according to service life calculations.

Maximum Load Weight

Select the load from within the range of limits shown in the graphs. Note that the maximum allowable moment value may sometimes be exceeded even within the operating limits shown in the graphs. Therefore, also check the allowable moment for the selected conditions.

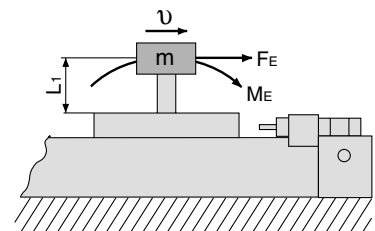

Mechanically Jointed Rodless Cylinder Cam Follower Guide Type Series MY1C

MY1C/M₁

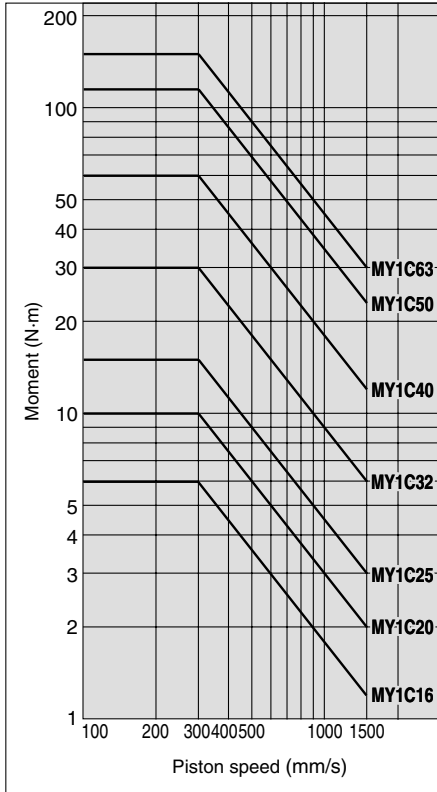

MY1C/M₂

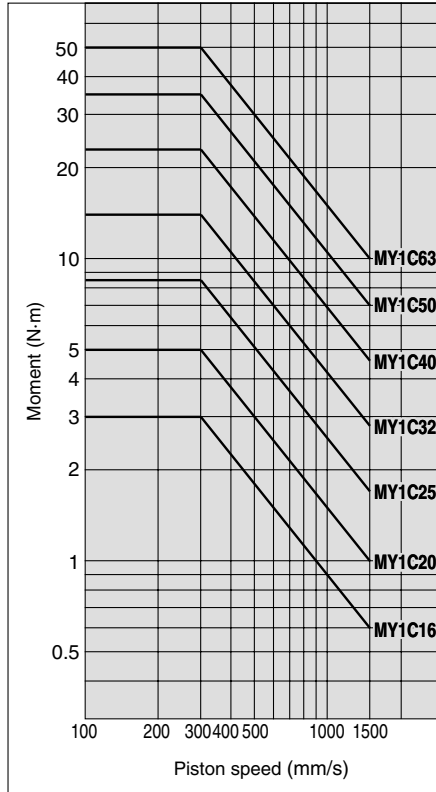

MY1C/M₃

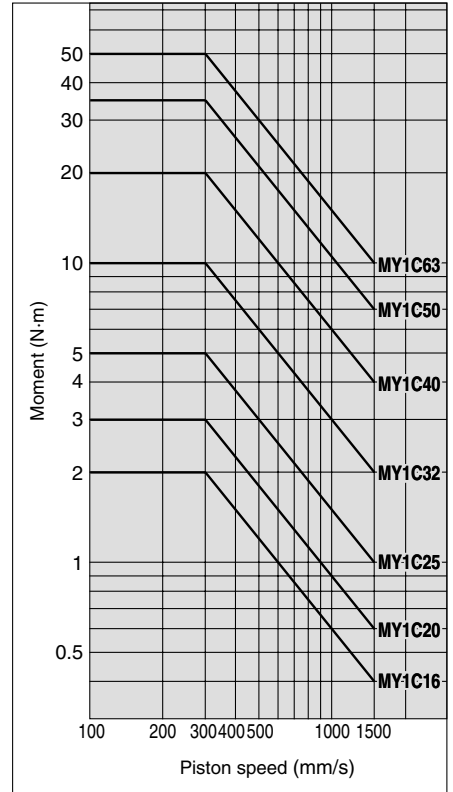

MX

MTS

MY

CY

MG

CX

D-

-X

20-

Data

MY1C/m₁

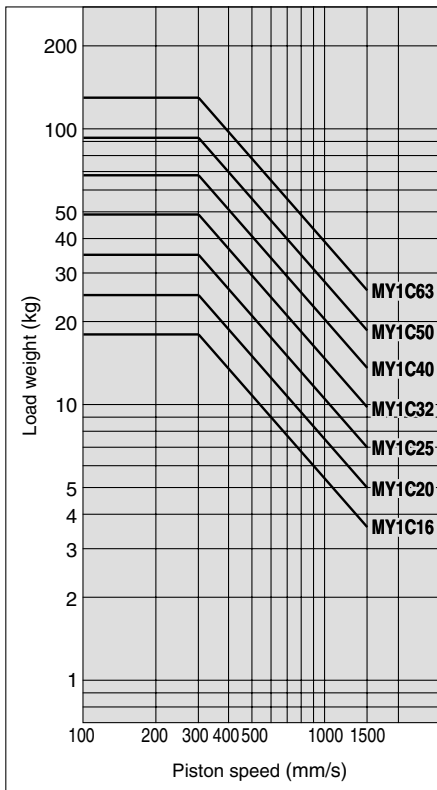

MY1C/m₂

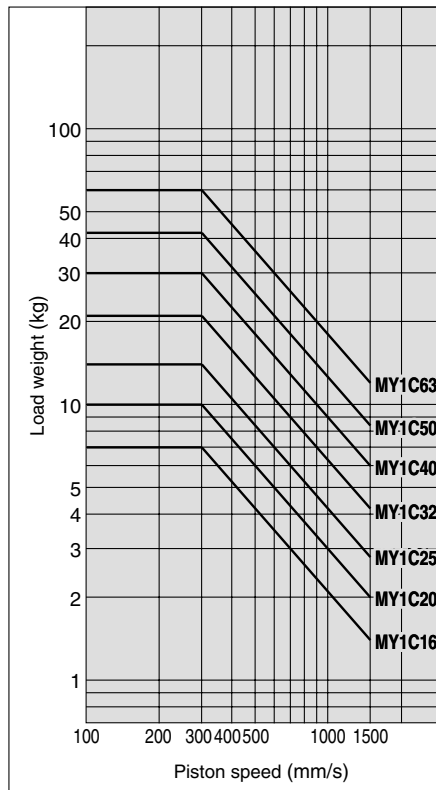

MY1C/m₃

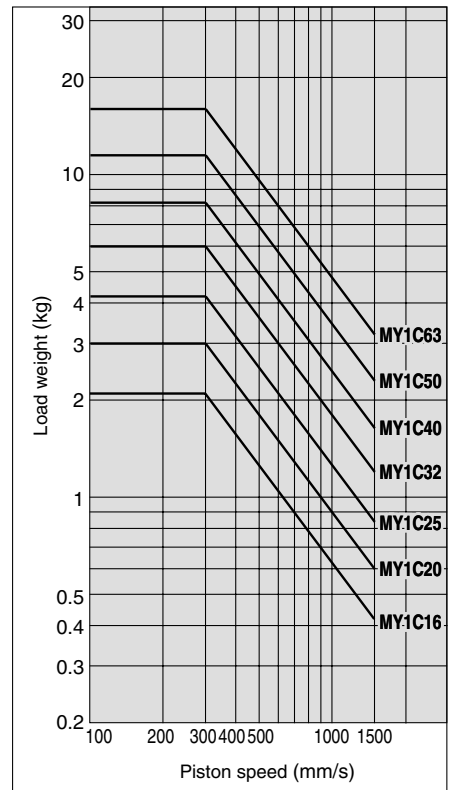

Model Selection

Following are the steps for selecting the most suitable Series MY1C to your application.

Calculation of Guide Load Factor

1. Operating Conditions

Cylinder..... MY1C40-500
 Average operating speed v_a ... 300 mm/s
 Mounting orientation..... Ceiling mounting
 Cushion..... Air cushion
 ($\delta = 1/100$)

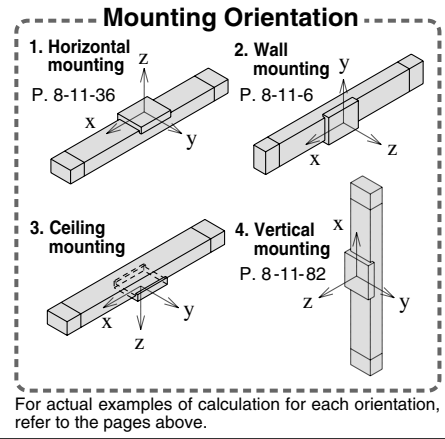
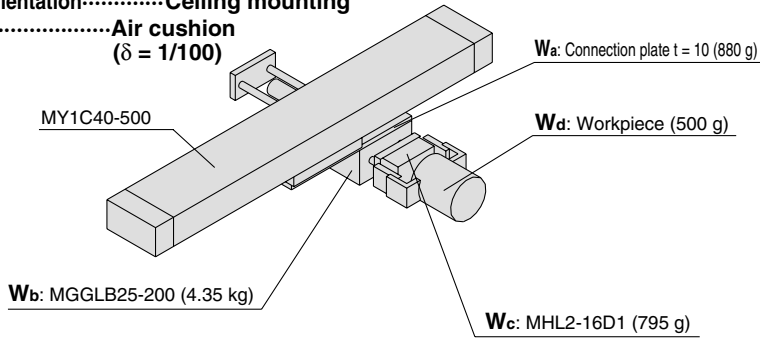

2. Load Blocking

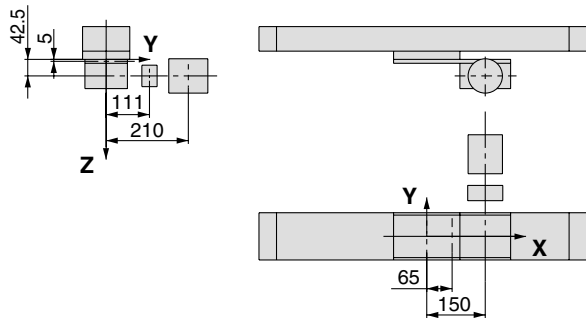

Weight and Center of Gravity for Each Workpiece

Workpiece no. W _n	Weight m _n	Center of gravity		
		X-axis X _n	Y-axis Y _n	Z-axis Z _n
W _a	0.88 kg	65 mm	0 mm	5 mm
W _b	4.35 kg	150 mm	0 mm	42.5 mm
W _c	0.795 kg	150 mm	111 mm	42.5 mm
W _d	0.5 kg	150 mm	210 mm	42.5 mm

n = a, b, c, d

3. Composite Center of Gravity Calculation

$$m_2 = \sum m_n = 0.88 + 4.35 + 0.795 + 0.5 = 6.525 \text{ kg}$$

$$X = \frac{1}{m_2} \times \sum (m_n \times X_n) = \frac{1}{6.525} (0.88 \times 65 + 4.35 \times 150 + 0.795 \times 150 + 0.5 \times 150) = 138.5 \text{ mm}$$

$$Y = \frac{1}{m_2} \times \sum (m_n \times Y_n) = \frac{1}{6.525} (0.88 \times 0 + 4.35 \times 0 + 0.795 \times 111 + 0.5 \times 210) = 29.6 \text{ mm}$$

$$Z = \frac{1}{m_2} \times \sum (m_n \times Z_n) = \frac{1}{6.525} (0.88 \times 5 + 4.35 \times 42.5 + 0.795 \times 42.5 + 0.5 \times 42.5) = 37.4 \text{ mm}$$

4. Calculation of Load Factor for Static Load

m₂: Weight
 m_{2max} (from (1) of graph MY1C/m₂) = 30 (kg).....
 Load factor $\alpha_1 = m_2/m_{2max} = 6.525/30 = 0.22$

M₁: Moment
 M_{1max} (from (2) of graph MY1C/M₁) = 60 (N·m).....
 M₁ = m₂ × g × X = 6.525 × 9.8 × 138.5 × 10⁻³ = 8.86 (N·m)
 Load factor $\alpha_2 = M_1/M_{1max} = 8.86/60 = 0.15$

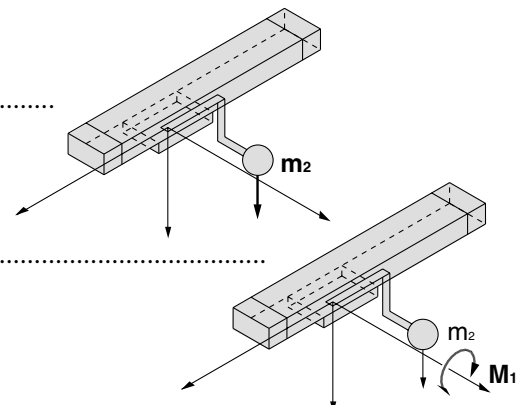

M₂: Moment

M_{2max} (from (3) of graph MY1C/M₂) = 23.0 (N·m).....

M₂ = m₂ × g × Y = 6.525 × 9.8 × 29.6 × 10⁻³ = 1.89 (N·m)

Load factor $\alpha_3 = M_2/M_{2max} = 1.89/23.0 = 0.08$

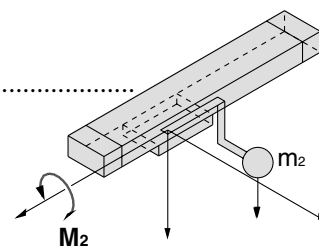

5. Calculation of Load Factor for Dynamic Moment

Equivalent load F_E at impact

F_E = 1.4v_a × δ × m × g = 1.4 × 300 × $\frac{1}{100}$ × 6.525 × 9.8 = 268.6 (N)

M_{1E}: Moment

M_{1E}max (from (4) of graph MY1C/M₁ where 1.4v_a = 420 mm/s) = 42.9 (N·m).....

M_{1E} = $\frac{1}{3}$ × F_E × Z = $\frac{1}{3}$ × 268.6 × 37.4 × 10⁻³ = 3.35 (N·m)

Load factor $\alpha_4 = M_{1E}/M_{1Emax} = 3.35/42.9 = 0.08$

M_{3E}: Moment

M_{3E}max (from (5) of graph MY1C/M₃ where 1.4v_a = 420 mm/s) = 14.3 (N·m).....

M_{3E} = $\frac{1}{3}$ × F_E × Y = $\frac{1}{3}$ × 268.6 × 29.6 × 10⁻³ = 2.65 (N·m)

Load factor $\alpha_5 = M_{3E}/M_{3Emax} = 2.65/14.3 = 0.19$

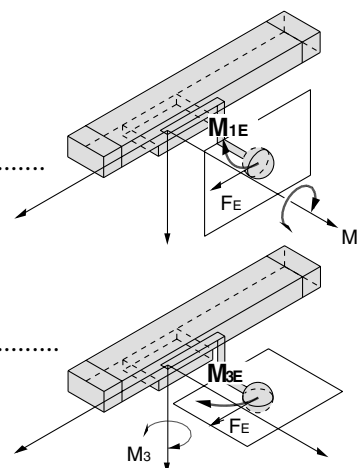

- MX
- MTS
- MY
- CY
- MG
- CX
- D-
- X
- 20-
- Data

6. Sum and Examination of Guide Load Factors

$$\Sigma\alpha = \alpha_1 + \alpha_2 + \alpha_3 + \alpha_4 + \alpha_5 = 0.72 \leq 1$$

The above calculation is within the allowable value, and therefore the selected model can be used.

Select a shock absorber separately.

In an actual calculation, when the total sum of guide load factors $\Sigma\alpha$ in the formula above is more than 1, consider either decreasing the speed, increasing the bore size, or changing the product series. This calculation can be easily made using the "SMC Pneumatics CAD System".

Load Weight

MY1C/m₂

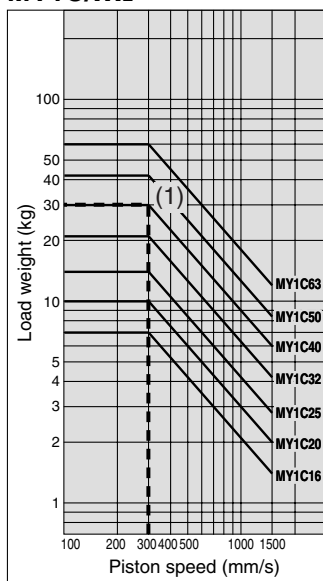

Allowable Moment

MY1C/M₁

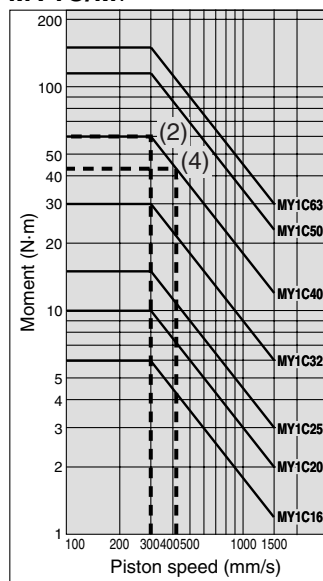

MY1C/M₂

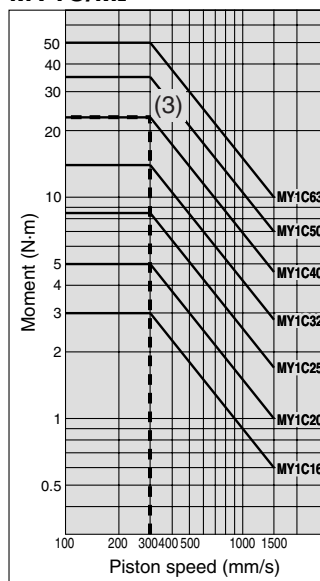

MY1C/M₃

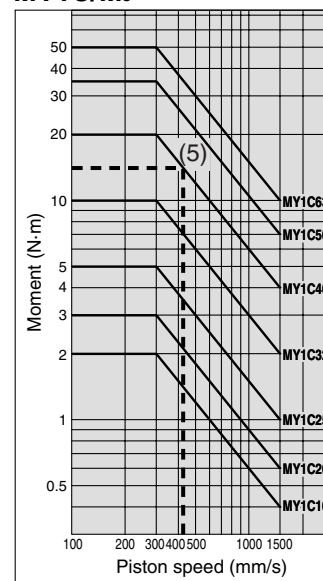

Mechanically Jointed Rodless Cylinder Cam Follower Guide Type



Series MY1C

ø16, ø20, ø25, ø32, ø40, ø50, ø63

How to Order

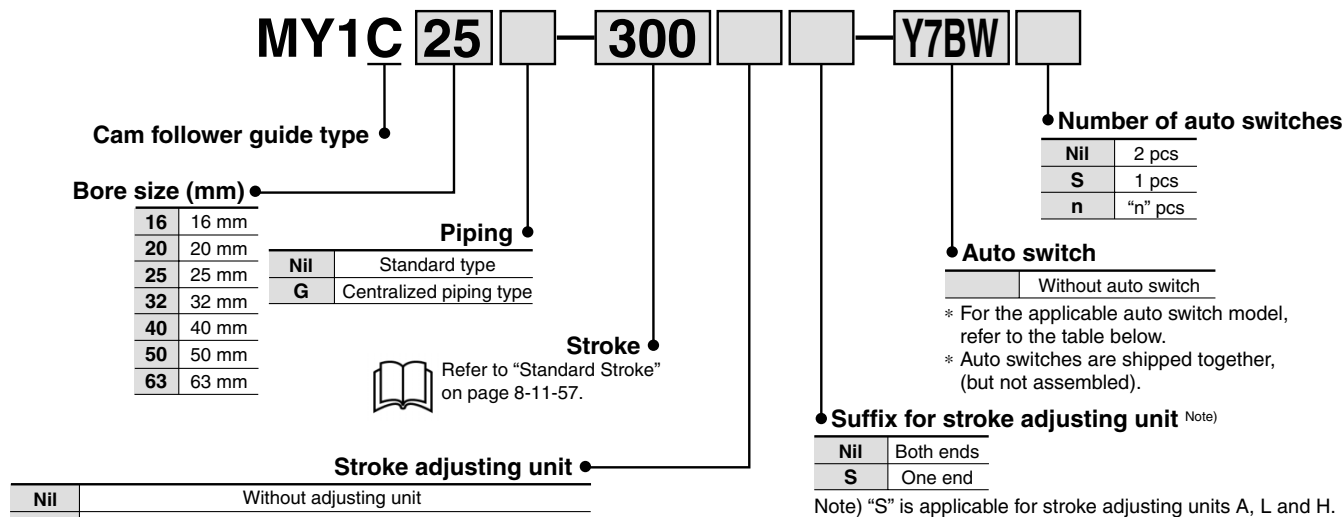

Shock Absorbers for L and H Units

Unit type	Bore size (mm)						
	16	20	25	32	40	50	63
L unit	RB0806		RB1007		RB1412		RB2015
H unit	—	RB1007	RB1412		RB2015		RB2725

Applicable Auto Switch/Refer to page 8-30-1 for further information on auto switches. For ø16, ø20

Type	Special function	Electrical entry	Indicator light	Wiring (Output)	Load voltage			Auto switch model		Lead wire length (m)*			Pre-wire connector	Applicable load	
					DC	AC	AC	Perpendicular	In-line	0.5 (Nil)	3 (L)	5 (Z)			
Reed switch	—	Grommet	Yes	3-wire (NPN equivalent)	—	5 V	—	A96V	A96	●	●	—	—	IC circuit	
				2-wire	24 V	12 V	100 V	A93V	A93	●	●	—	—	—	Relay, PLC
Solid state switch	—	Grommet	Yes	3-wire (NPN)	24 V	5 V, 12 V	—	M9NV	M9N	●	●	○	○	IC circuit	
				3-wire (PNP)				M9PV	M9P	●	●	○	○	—	
				2-wire				M9BV	M9B	●	●	○	○	—	
	Diagnostic indication (2-color indication)			3-wire (NPN)	24 V	5 V, 12 V	—	F9NWV	F9NW	●	●	○	○	—	IC circuit
				3-wire (PNP)				F9PWV	F9PW	●	●	○	○	—	
				2-wire				F9BWV	F9BW	●	●	○	○	—	

For ø25, ø32, ø40, ø50, ø63

Type	Special function	Electrical entry	Indicator light	Wiring (Output)	Load voltage			Auto switch model		Lead wire length (m)*			Pre-wire connector	Applicable load	
					DC	AC	AC	Perpendicular	In-line	0.5 (Nil)	3 (L)	5 (Z)			
Reed switch	—	Grommet	Yes	3-wire (NPN equivalent)	—	5 V	—		Z76	●	●	—	—	IC circuit	
				2-wire	24 V	12 V	100 V		Z73	●	●	●	—	—	Relay, PLC
Solid state switch	—	Grommet	Yes	3-wire (NPN)	24 V	5 V, 12 V	—	Y69A	Y59A	●	●	○	○	IC circuit	
				3-wire (PNP)				Y7PV	Y7P	●	●	○	○	—	
				2-wire				Y69B	Y59B	●	●	○	○	—	
	Diagnostic indication (2-color indication)			3-wire (NPN)	24 V	5 V, 12 V	—	Y7NWV	Y7NW	●	●	○	○	—	IC circuit
				3-wire (PNP)				Y7PWV	Y7PW	●	●	○	○	—	
				2-wire				Y7BWV	Y7BW	●	●	○	○	—	

* Lead wire length symbols: 0.5 m...Nil (Example) A93
3 m...L (Example) Y59BL
5 m...Z (Example) F9NWZ

* Solid state switches marked with "○" are produced upon receipt of order.

- There are other applicable auto switches than listed above. For details, refer to page 8-11-101.
- For details about auto switches with pre-wire connector, refer to page 8-30-52.

Mechanically Jointed Rodless Cylinder Cam Follower Guide Type Series MY1C

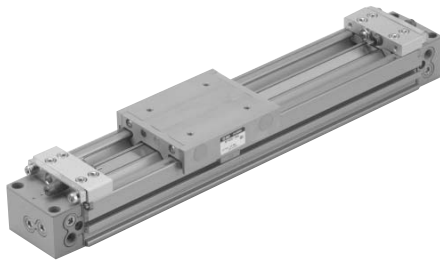

JIS Symbol

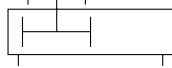

Specifications

Bore size (mm)	16	20	25	32	40	50	63
Fluid	Air						
Action	Double acting						
Operating pressure range	0.1 to 0.8 MPa						
Proof pressure	1.2 MPa						
Ambient and fluid temperature	5 to 60°C						
Cushion	Air cushion						
Lubrication	Non-lube						
Stroke length tolerance	1000 or less $\begin{smallmatrix} +1.8 \\ 0 \end{smallmatrix}$ 1001 to 3000 $\begin{smallmatrix} +2.8 \\ 0 \end{smallmatrix}$		2700 or less $\begin{smallmatrix} +1.8 \\ 0 \end{smallmatrix}$, 2701 to 5000 $\begin{smallmatrix} +2.8 \\ 0 \end{smallmatrix}$				
Piping port size	Front/Side port	M5 x 0.8			Rc 1/8	Rc 1/4	Rc 3/8
	Bottom port	ø4			ø5	ø6	ø8
				ø8	ø10	ø11	

Stroke Adjusting Unit Specifications

Bore size (mm)	16			20			25			32			40			50			63		
Unit symbol	A	L	H	A	L	H	A	L	H	A	L	H	A	L	H	A	L	H	A	L	H
Configuration Shock absorber model	With adjusting bolt	RB 0806 with adjusting bolt	RB 1007 with adjusting bolt	With adjusting bolt	RB 0806 with adjusting bolt	RB 1007 with adjusting bolt	With adjusting bolt	RB 1007 with adjusting bolt	RB 1412 with adjusting bolt	With adjusting bolt	RB 1412 with adjusting bolt	RB 2015 with adjusting bolt	With adjusting bolt	RB 1412 with adjusting bolt	RB 2015 with adjusting bolt	With adjusting bolt	RB 2015 with adjusting bolt	RB 2725 with adjusting bolt	With adjusting bolt	RB 2015 with adjusting bolt	RB 2725 with adjusting bolt
Fine stroke adjustment range (mm)	0 to -5.6			0 to -6			0 to -11.5			0 to -12			0 to -16			0 to -20			0 to -25		
Stroke adjustment range	When exceeding the stroke fine adjustment range: Utilize a made-to-order specifications "-X416" and "-X417".																				

Shock Absorber Specifications

Model	RB 0806	RB 1007	RB 1412	RB 2015	RB 2725	
Max. energy absorption (J)	2.9	5.9	19.6	58.8	147	
Stroke absorption (mm)	6	7	12	15	25	
Max. collision speed (mm/s)	1500					
Max. operating frequency (cycle/min)	80	70	45	25	10	
Spring force (N)	Extended	1.96	4.22	6.86	8.34	8.83
	Retracted	4.22	6.86	15.98	20.50	20.01
Operating temperature range (°C)	5 to 60					

Piston Speed

Bore size (mm)	16 to 63	
Without stroke adjusting unit	100 to 1000 mm/s	
Stroke adjusting unit	A unit	100 to 1000 mm/s ⁽¹⁾
	L unit and H unit	100 to 1500 mm/s ⁽²⁾

Note 1) Be aware that when the stroke adjusting range is increased by manipulating the adjusting bolt, the air cushion capacity decreases. Also, when exceeding the air cushion stroke ranges on page 8-11-59.

Note 2) The piston speed is 100 to 1000 mm/s for centralized piping.

Note 3) Use at a speed within the absorption capacity range. Refer to page 8-11-59.

Made to Order Specifications (For details, refer to page 8-31-1.)

Symbol	Specifications
-XB11	Long stroke
-XC18	NPT finish piping port
-XC56	With knock pin hole
-XC67	NBR rubber lining in dust seal band
-X168	Helical insert thread specifications
-X416	Holder mounting bracket I
-X417	Holder mounting bracket II

Standard Stroke

Bore size (mm)	Standard stroke (mm) *	Maximum manufacturable stroke (mm)
16	100, 200, 300, 400, 500, 600, 700, 800, 900, 1000, 1200, 1400, 1600, 1800, 2000	3000
20, 25, 32, 40, 50, 63		5000

* Strokes are manufacturable in 1 mm increments, up to the maximum stroke. However, when exceeding a 2000 mm stroke, specify "-XB11" at the end of the model number.

Series MY1C

Theoretical Output (N)

Bore size (mm)	Piston area (mm ²)	Operating pressure (MPa)							
		0.2	0.3	0.4	0.5	0.6	0.7	0.8	
16	200	40	60	80	100	120	140	160	
20	314	62	94	125	157	188	219	251	
25	490	98	147	196	245	294	343	392	
32	804	161	241	322	402	483	563	643	
40	1256	251	377	502	628	754	879	1005	
50	1962	392	588	784	981	1177	1373	1569	
63	3115	623	934	1246	1557	1869	2180	2492	

Note) Theoretical output (N) = Pressure (MPa) x Piston area (mm²)

Weight (kg)

Bore size (mm)	Basic weight	Additional weight per each 50mm of stroke	Side support weight (per set)	Stroke adjusting unit weight (per unit)		
			Type A and B	A unit weight	L unit weight	H unit weight
16	0.67	0.12	0.01	0.03	0.04	—
20	1.06	0.15	0.02	0.04	0.05	0.08
25	1.58	0.24	0.02	0.07	0.11	0.18
32	3.14	0.37	0.04	0.14	0.23	0.39
40	5.60	0.52	0.08	0.25	0.34	0.48
50	10.14	0.76	0.08	0.36	0.51	0.81
63	16.67	1.10	0.17	0.68	0.83	1.08

Calculation: (Example) MY1C25-300A

- Basic weight 1.58 kg
 - Additional weight 0.24/50 st
 - Weight of A unit 0.07 kg
 - Cylinder stroke.....300 st
- $1.58 + 0.24 \times 300 \div 50 + 0.07 \times 2 \approx 3.16$ kg

Option

Stroke Adjusting Unit Part No.

Bore size (mm)	16	20	25	32
A unit	MYM-A16A	MYM-A20A	MYM-A25A	MYM-A32A
L unit	MYM-A16L	MYM-A20L	MYM-A25L	MYM-A32L
H unit	—	MYM-A20H	MYM-A25H	MYM-A32H

Bore size (mm)	40	50	63
A unit	MYM-A40A	MYM-A50A	MYM-A63A
L unit	MYM-A40L	MYM-A50L	MYM-A63L
H unit	MYM-A40H	MYM-A50H	MYM-A63H

Side Support Part No.

Bore size (mm)	16	20	25	32
Side support A	MY-S16A	MY-S20A	MY-S25A	MY-S32A
Side support B	MY-S16B	MY-S20B	MY-S25B	MY-S32B

Bore size (mm)	40	50	63
Side support A	MY-S40A	MY-S50A	MY-S63A
Side support B	MY-S40B	MY-S50B	MY-S63B

For details about dimensions, etc., refer to page 8-11-65.

Cushion Capacity

Cushion Selection

<Air cushion>

Air cushions are a standard feature on mechanically jointed rodless cylinders. The air cushion mechanism is incorporated to prevent excessive impact of the piston at the stroke end during high speed operation. The purpose of air cushion, thus, is not to decelerate the piston near the stroke end.

The ranges of load and speed that air cushions can absorb are within the air cushion limit lines shown in the graphs.

<Stroke adjusting unit with shock absorber>

Use this unit when operating with a load or speed exceeding the air cushion limit line, or when cushioning is necessary because the cylinder stroke is outside of the effective air cushion stroke range due to stroke adjustment.

L unit

Use this unit when the cylinder stroke is outside of the effective air cushion range even if the load and speed are within the air cushion limit line, or when the cylinder is operated in a load and speed range above the air cushion limit line or below the L unit limit line.

H unit

Use this unit when the cylinder is operated in a load and speed range above the L unit limit line and below the H unit limit line.

⚠ Caution

1. Refer to the figure below when using the adjusting bolt to perform stroke adjustment.

When the effective stroke of the shock absorber decreases as a result of stroke adjustment, the absorption capacity decreases dramatically. Secure the adjusting bolt at the position where it protrudes approximately 0.5 mm from the shock absorber.

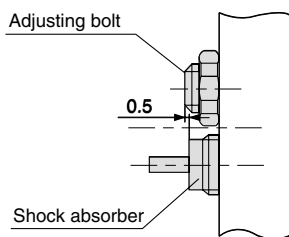

2. Do not use a shock absorber together with air cushion.

Air Cushion Stroke (mm)

Bore size (mm)	Cushion stroke
16	12
20	15
25	15
32	19
40	24
50	30
63	37

Absorption Capacity of Air Cushion and Stroke Adjusting Units

MY1C16 Horizontal collision: P = 0.5 MPa

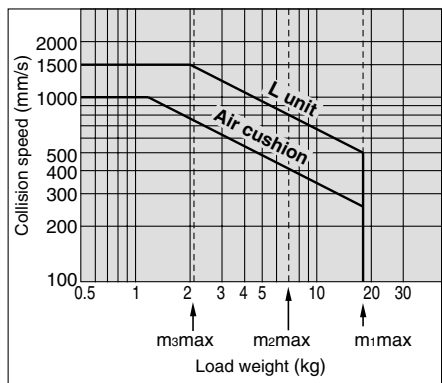

MY1C32 Horizontal collision: P = 0.5 MPa

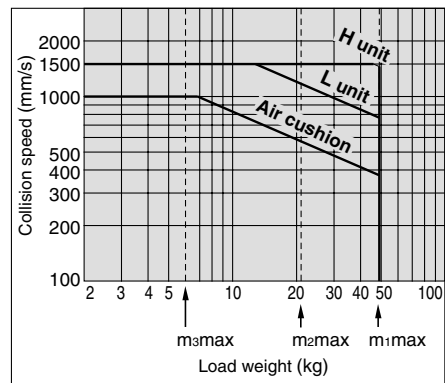

MY1C20 Horizontal collision: P = 0.5 MPa

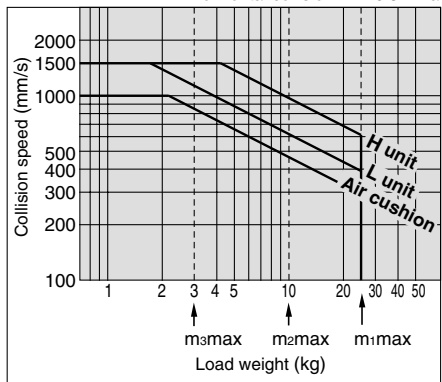

MY1C40 Horizontal collision: P = 0.5 MPa

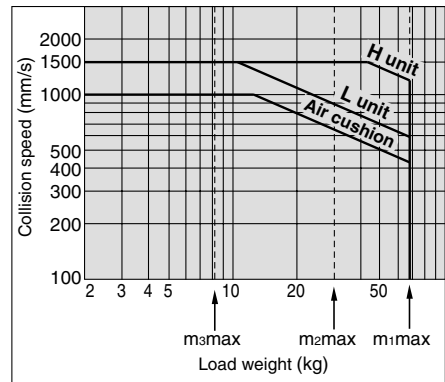

MY1C25 Horizontal collision: P = 0.5 MPa

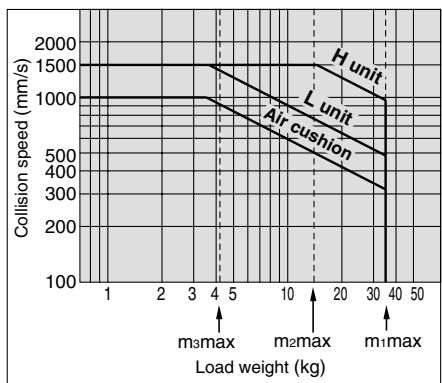

MY1C50 Horizontal collision: P = 0.5 MPa

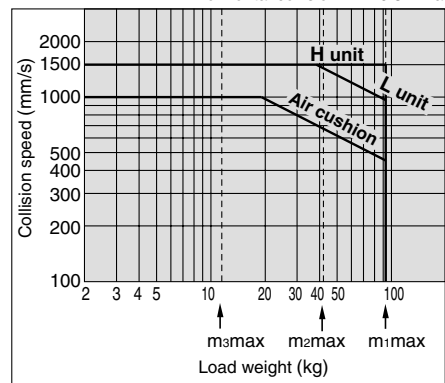

MY1C63 Horizontal collision: P = 0.5 MPa

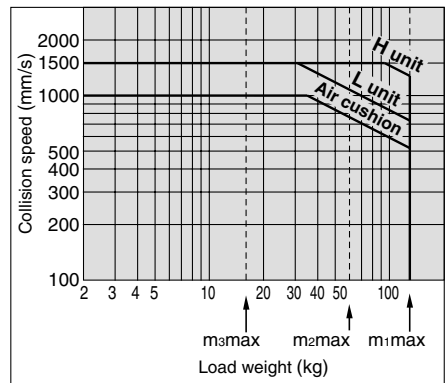

- MX
- MTS
- MY
- CY
- MG
- CX
- D-
- X
- 20-
- Data

Series MY1C

Cushion Capacity

Tightening Torque for Stroke Adjusting Unit Holding Bolts (N·m)

Bore size (mm)	Unit	Tightening torque
16	A	0.6
	L	
20	A	1.5
	H	
25	A	3.0
	L	5.0
	H	12
32	A	5.0
	L	12
	H	12
40	A	12
	L	12
	H	12
50	A	12
	L	12
	H	12
63	A	24
	L	24
	H	24

Tightening Torque for Stroke Adjusting Unit Lock Plate Holding Bolts (N·m)

Bore size (mm)	Unit	Tightening torque
25	L	1.2
	H	3.3
32	L	3.3
	H	10
40	L	3.3
	H	10

Calculation of Absorbed Energy for Stroke Adjusting Unit with Shock Absorber (N·m)

Type of impact	Horizontal collision	Vertical (Downward)	Vertical (Upward)
Kinetic energy E ₁		$\frac{1}{2} m \cdot v^2$	
Thrust energy E ₂	F·s	F·s + m·g·s	F·s - m·g·s
Absorbed energy E		E ₁ + E ₂	

Symbol

- v: Speed of impact object (m/s)
- F: Cylinder thrust (N)
- s: Shock absorber stroke (m)
- m: Weight of impact object (kg)
- g: Gravitational acceleration (9.8 m/s²)

Note) The speed of the impact object is measured at the time of impact with the shock absorber.

⚠ Precautions

Be sure to read before handling. For Safety Instructions and Actuator Precautions, refer to pages 8-34-3 to 8-34-6.

⚠ Caution

Use caution not to get your hands caught in the unit.

- When using a product with stroke adjusting unit, the space between the slide table (slider) and the stroke adjusting unit becomes narrow at the stroke end, causing a danger of hands getting caught. Install a protective cover to prevent direct contact with the human body.

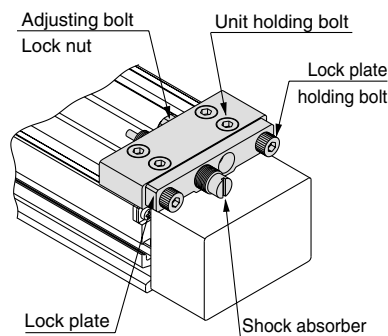

<Fastening of unit>

The unit can be secured by evenly tightening the four unit holding bolts.

⚠ Caution

Do not operate with the stroke adjusting unit fixed in an intermediate position.

When the stroke adjusting unit is fixed in an intermediate position, slippage can occur depending on the amount of energy released at the time of an impact. In such cases, the use of the adjusting bolt mounting brackets, available per made-to-order specifications -X416 and -X417, is recommended.

For other lengths, please consult with SMC (Refer to "Tightening Torque for Stroke Adjusting Unit Holding Bolts".)

<Stroke adjustment with adjusting bolt>

Loosen the adjusting bolt lock nut, and adjust the stroke from the lock plate side using a hexagon wrench. Retighten the lock nut.

<Stroke adjustment with shock absorber>

Loosen the two lock plate holding bolts, turn the shock absorber and adjust the stroke. Then, uniformly tighten the lock plate holding bolts to secure the shock absorber.

Take care not to over-tighten the holding bolts. (Except ø16, ø20, ø50, ø63) (Refer to "Tightening Torque for Stroke Adjusting Unit Lock Plate Holding Bolts".)

Note) Although the lock plate may slightly bend due to tightening of the lock plate holding bolt, this does not affect the shock absorber and locking function.

Mechanically Jointed Rodless Cylinder Cam Follower Guide Type **Series MY1C**

Standard Type/Centralized Piping Type $\phi 16, \phi 20$

Refer to page 8-11-9 regarding centralized piping port variations.

MY1C16□/20□ — Stroke

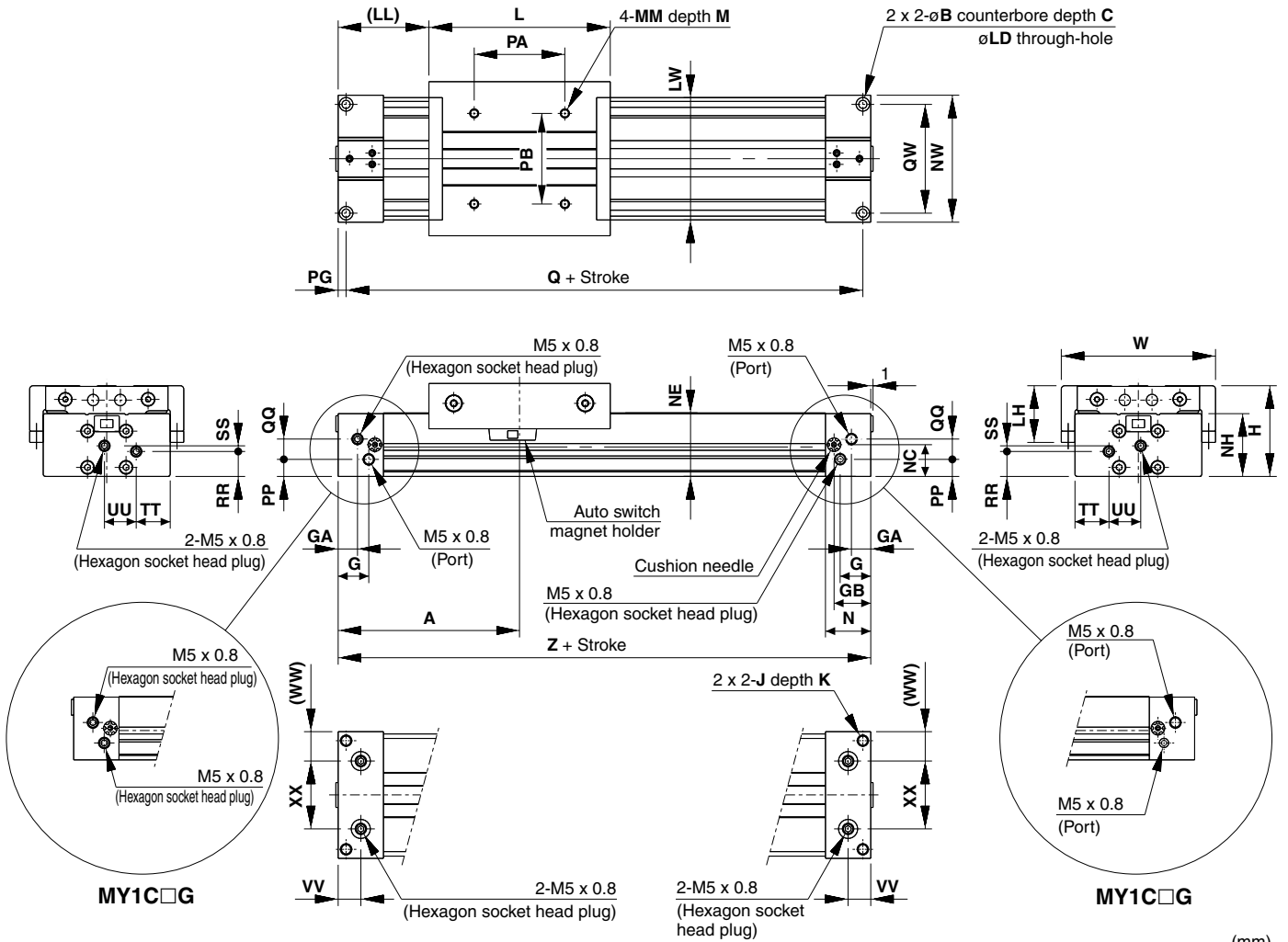

- MX□
- MTS
- MY□**
- CY□
- MG□
- CX□
- D-
- X
- 20-
- Data

Model	A	B	C	G	GA	GB	H	J	K	L	LD	LH	LL	LW	M	MM	N	NC
MY1C16□	80	6	3.5	13.5	8.5	16.2	40	M5 x 0.8	10	80	3.6	22.5	40	54	6	M4 x 0.7	20	14
MY1C20□	100	7.5	4.5	12.5	12.5	20	46	M6 x 1	12	100	4.8	23	50	58	7.5	M5 x 0.8	25	17

Model	NE	NH	NW	PA	PB	PG	PP	Q	QQ	QW	RR	SS	TT	UU	VV	W	WW	XX	Z
MY1C16□	28	27.7	56	40	40	3.5	7.5	153	9	48	11	2.5	15	14	10	68	13	30	160
MY1C20□	34	33.7	60	50	40	4.5	11.5	191	10	45	14.5	5	18	12	12.5	72	14	32	200

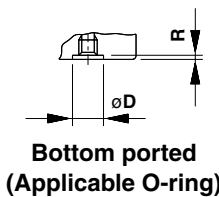
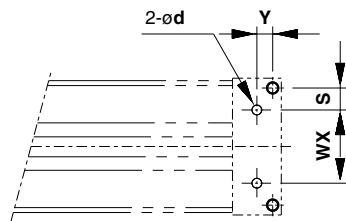

Hole Sizes for Centralized Piping on the Bottom

Model	WX	Y	S	d	D	R	Applicable O-ring
MY1C16□	30	6.5	9	4	8.4	1.1	C6
MY1C20□	32	8	6.5	4	8.4	1.1	

(Machine the mounting side to the dimensions below.)

Series MY1C

Standard Type/Centralized Piping Type $\phi 25$, $\phi 32$, $\phi 40$ Refer to page 8-11-9 regarding centralized piping port variations.

MY1C25□/32□/40□ — Stroke

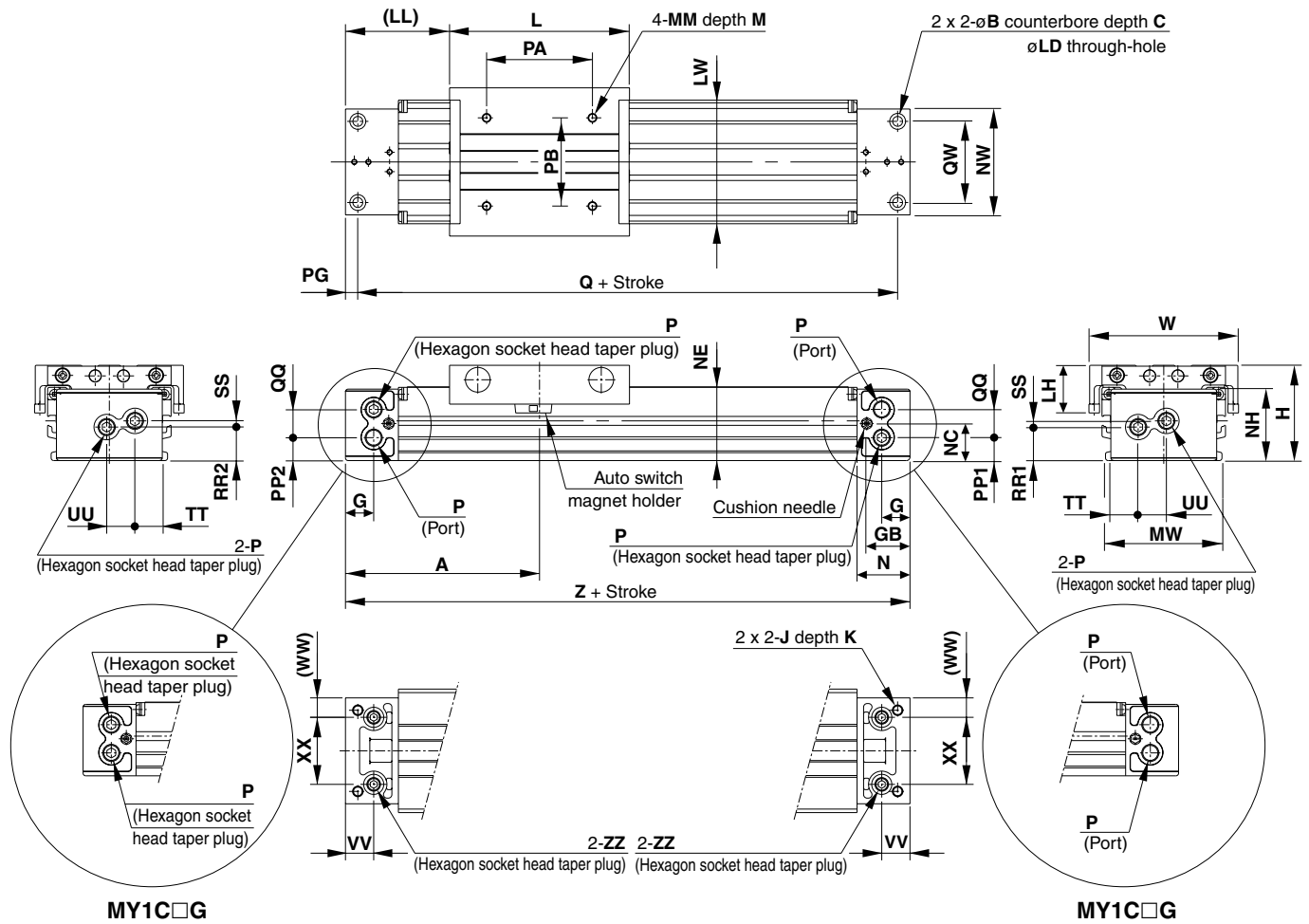

MY1C□G

MY1C□G

Model	A	B	C	G	GB	H	J	K	L	LD	LH	LL	LW	M	MM	MW	N	NC	NE	NH	NW	P	PA
MY1C25□	110	9	5.5	17	24.5	54	M6 x 1	9.5	102	5.6	27	59	70	10	M5 x 0.8	66	30	21	41.8	40.5	60	Rc 1/8	60
MY1C32□	140	11	6.5	19	30	68	M8 x 1.25	16	132	6.8	35	74	88	13	M6 x 1	80	37	26	52.3	50	74	Rc 1/8	80
MY1C40□	170	14	8.5	23	36.5	84	M10 x 1.5	15	162	8.6	38	89	104	13	M6 x 1	96	45	32	65.3	63.5	94	Rc 1/4	100

(mm)

"P" indicates cylinder supply ports.

Model	PB	PG	PP1	PP2	Q	QQ	QW	RR1	RR2	SS	TT	UU	VV	W	WW	XX	Z	ZZ
MY1C25□	50	7	12.7	12.7	206	15.5	46	18.9	17.9	4.1	15.5	16	16	84	11	38	220	Rc 1/16
MY1C32□	60	8	15.5	18.5	264	16	60	22	24	4	21	16	19	102	13	48	280	Rc 1/16
MY1C40□	80	9	17.5	20	322	26	72	25.5	29	9	26	21	23	118	20	54	340	Rc 1/8

(mm)

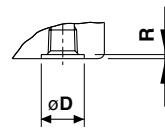
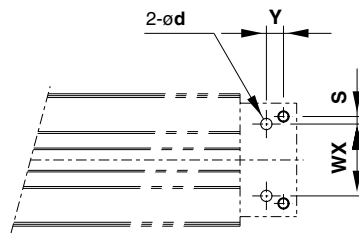

Bottom ported (ZZ)
(Applicable O-ring)

Hole Size for Centralized Piping on the Bottom

Model	WX	Y	S	d	D	R	Applicable O-ring
MY1C25□	38	9	4	6	11.4	1.1	C9
MY1C32□	48	11	6	6	11.4	1.1	
MY1C40□	54	14	9	8	13.4	1.1	

(Machine the mounting side to the dimensions below.)

Series MY1C

Stroke Adjusting Unit

With adjusting bolt

MY1C Bore size □ — Stroke A

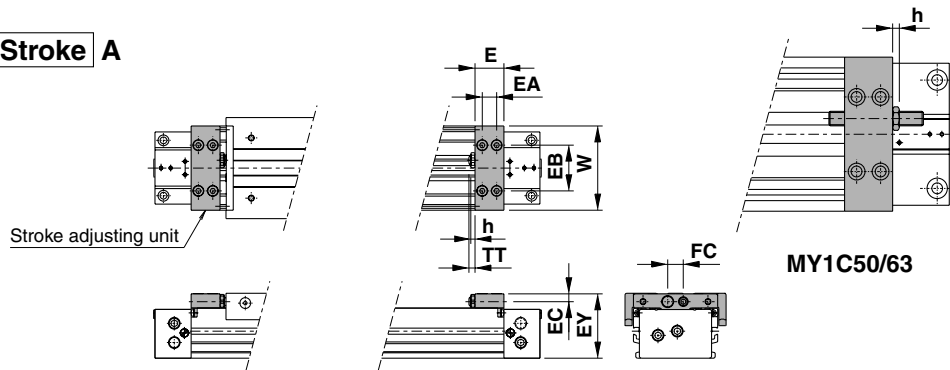

Applicable bore size	E	EA	EB	EC	EY	FC	h	TT	W
MY1C16	14.6	7	30	5.8	39.5	14	3.6	5.4 (Max. 11)	58
MY1C20	20	10	32	5.8	45.5	14	3.6	5 (Max. 11)	58
MY1C25	24	12	38	6.5	53.5	13	3.5	5 (Max. 16.5)	70
MY1C32	29	14	50	8.5	67	17	4.5	8 (Max. 20)	88
MY1C40	35	17	57	10	83	17	4.5	9 (Max. 25)	104
MY1C50	40	20	66	14	106	26	5.5	13 (Max. 33)	128
MY1C63	52	26	77	14	129	31	5.5	13 (Max. 38)	152

With low load shock absorber + Adjusting bolt

MY1C Bore size □ — Stroke A

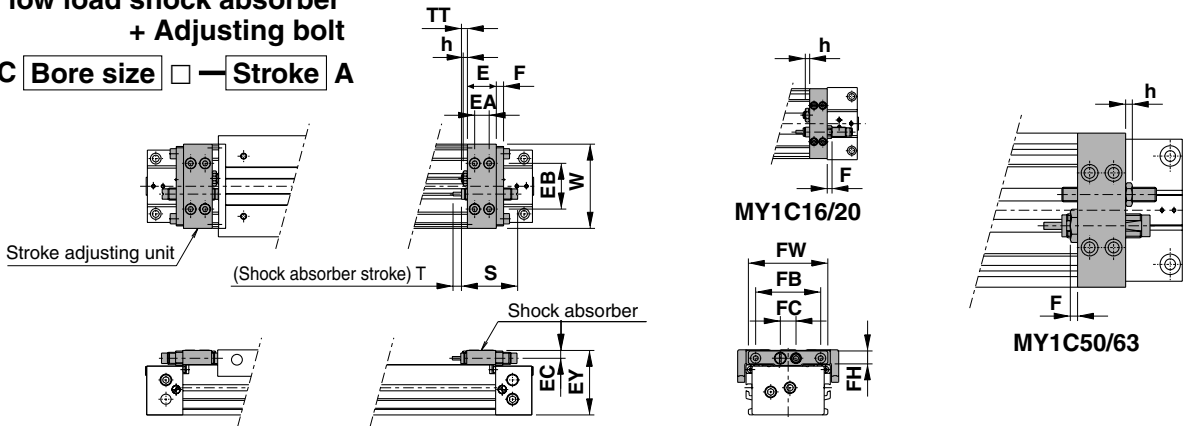

Applicable bore size	E	EA	EB	EC	EY	F	FB	FC	FH	FW	h	S	T	TT	W	Shock absorber model
MY1C16	14.6	7	30	5.8	39.5	4	—	14	—	—	3.6	40.8	6	5.4 (Max. 11)	58	RB0806
MY1C20	20	10	32	5.8	45.5	4	—	14	—	—	3.6	40.8	6	5 (Max. 11)	58	RB0806
MY1C25	24	12	38	6.5	53.5	6	54	13	13	66	3.5	46.7	7	5 (Max. 16.5)	70	RB1007
MY1C32	29	14	50	8.5	67	6	67	17	16	80	4.5	67.3	12	8 (Max. 20)	88	RB1412
MY1C40	35	17	57	10	83	6	78	17	17.5	91	4.5	67.3	12	9 (Max. 25)	104	RB1412
MY1C50	40	20	66	14	106	6	—	26	—	—	5.5	73.2	15	13 (Max. 33)	128	RB2015
MY1C63	52	26	77	14	129	6	—	31	—	—	5.5	73.2	15	13 (Max. 38)	152	RB2015

With high load shock absorber + Adjusting bolt

MY1C Bore size □ — Stroke A

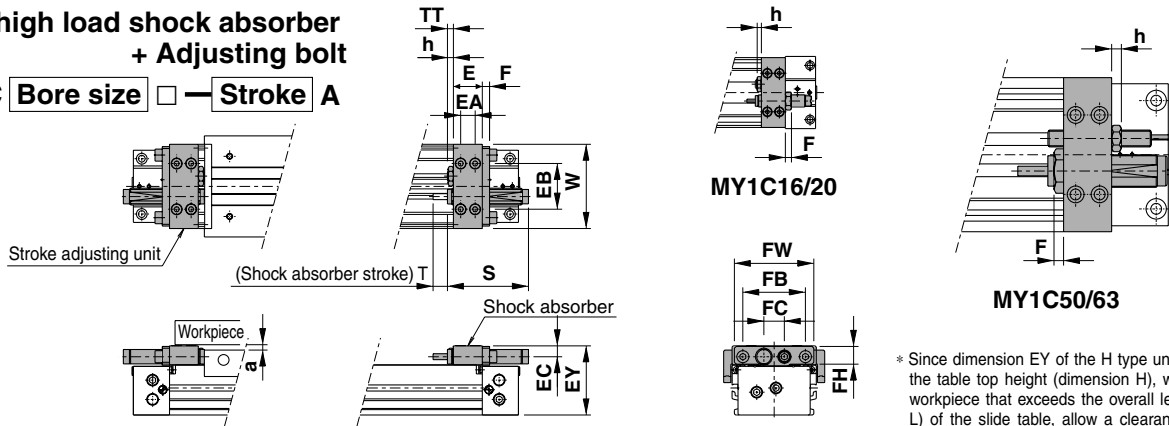

* Since dimension EY of the H type unit is greater than the table top height (dimension H), when mounting a workpiece that exceeds the overall length (dimension L) of the slide table, allow a clearance of dimension "a" or larger on the workpiece side.

Applicable bore size	E	EA	EB	EC	EY	F	FB	FC	FH	FW	h	S	T	TT	W	Shock absorber model	a
MY1C20	20	10	32	7.7	50	5	—	14	—	—	3.5	46.7	7	5 (Max. 11)	58	RB1007	5
MY1C25	24	12	38	9	57.5	6	52	17	16	66	4.5	67.3	12	5 (Max. 16.5)	70	RB1412	4.5
MY1C32	29	14	50	11.5	73	8	67	22	22	82	5.5	73.2	15	8 (Max. 20)	88	RB2015	6
MY1C40	35	17	57	12	87	8	78	22	22	95	5.5	73.2	15	9 (Max. 25)	104	RB2015	4
MY1C50	40	20	66	18.5	115	8	—	30	—	—	11	99	25	13 (Max. 33)	128	RB2725	9
MY1C63	52	26	77	19	138.5	8	—	35	—	—	11	99	25	13 (Max. 38)	152	RB2725	9.5

Side Support

Side support A MY-S□□A

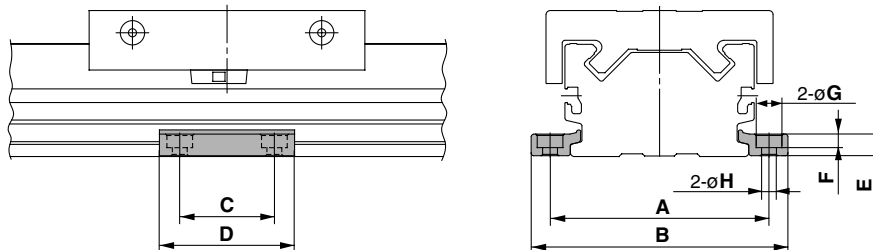

Side support B MY-S□□B

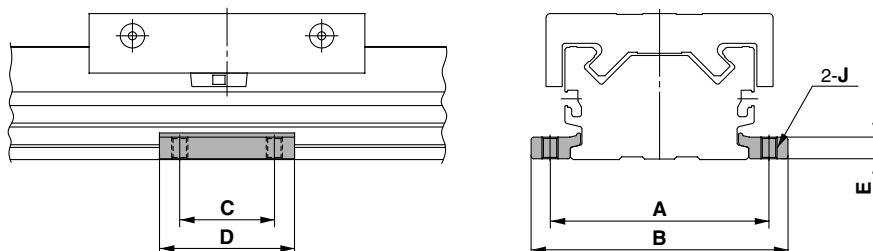

Model	Applicable bore size	A	B	C	D	E	F	G	H	J
MY-S16 ^A _B	MY1C16	61	71.6	15	26	4.9	3	6.5	3.4	M4 x 0.7
MY-S20 ^A _B	MY1C20	67	79.6	25	38	6.4	4	8	4.5	M5 x 0.8
MY-S25 ^A _B	MY1C25	81	95	35	50	8	5	9.5	5.5	M6 x 1
MY-S32 ^A _B	MY1C32	100	118	45	64	11.7	6	11	6.6	M8 x 1.25
MY-S40 ^A _B	MY1C40	120	142	55	80	14.8	8.5	14	9	M10 x 1.5
MY-S40 ^A _B	MY1C50	142	164							
MY-S63 ^A _B	MY1C63	172	202	70	100	18.3	10.5	17.5	11.5	M12 x 1.75

- MX□
- MTS
- MY□
- CY□
- MG□
- CX□
- D-
- X
- 20-
- Data

Guide for Side Support Application

For long stroke operation, the cylinder tube may be deflected depending on its own weight and the load weight. In such a case, use a side support in the middle section. The spacing (ℓ) of the support must be no more than the values shown in the graph on the right.

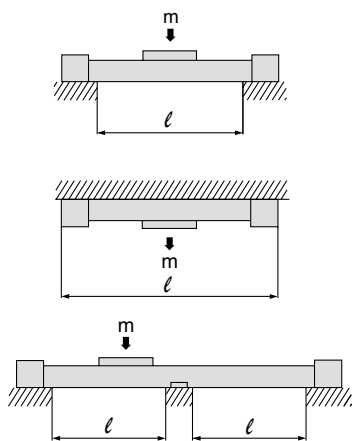

⚠ Caution

1. If the cylinder mounting surfaces are not measured accurately, using a side support may cause poor operation. Therefore, be sure to level the cylinder tube when mounting. Also, for long stroke operation involving vibration and impact, use of a side support is recommended even if the spacing value is within the allowable limits shown in the graph.
2. Support brackets are not for mounting; use them solely for providing support.

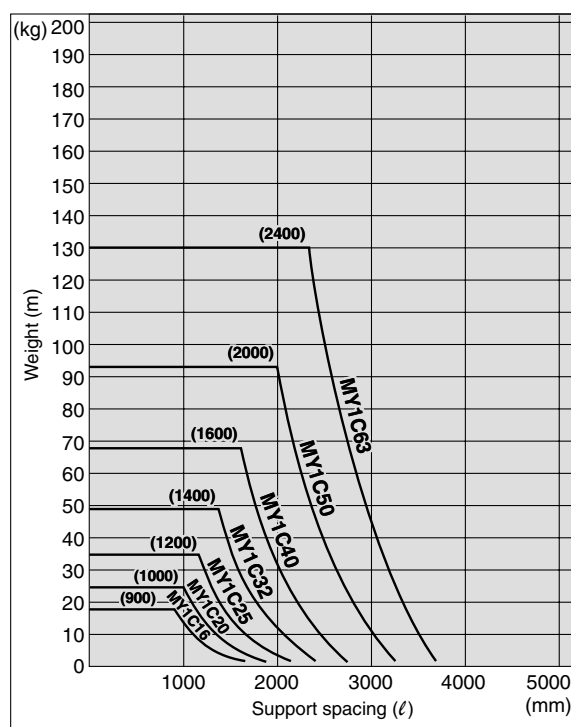

Series MY1C

Construction: $\varnothing 16$ to $\varnothing 63$

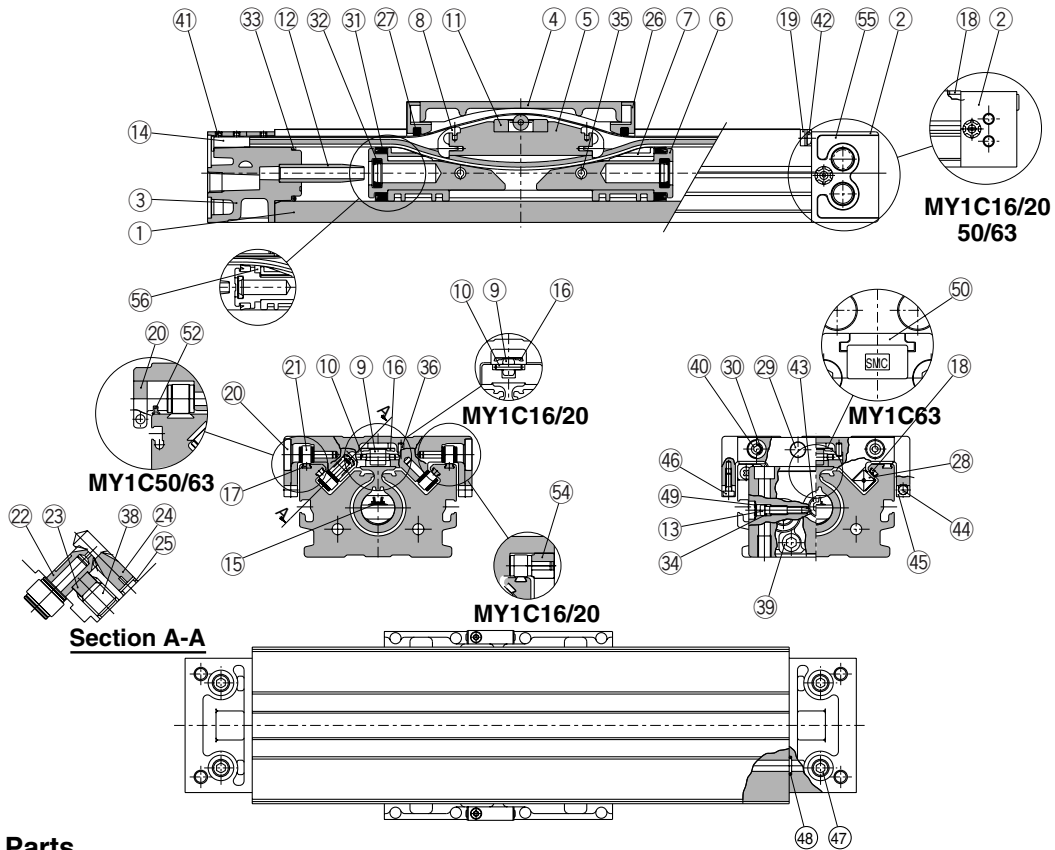

Component Parts

No.	Description	Material	Note
①	Cylinder tube	Aluminum alloy	Hard anodized
②	Head cover WR	Aluminum alloy	Painted
③	Head cover WL	Aluminum alloy	Painted
④	Slide table	Aluminum alloy	Electroless nickel plated
⑤	Piston yoke	Aluminum alloy	Chromated
⑥	Piston	Aluminum alloy	Chromated
⑦	Wear ring	Special resin	
⑧	Belt separator	Special resin	
⑨	Guide roller	Special resin	
⑩	Guide roller shaft	Stainless steel	
⑪	Coupler	Sintered iron material	
⑫	Cushion ring	Brass	
⑬	Cushion needle	Rolled steel	Nickel plated
⑭	Belt clamp	Special resin	
⑰	Rail	Hard steel wire material	
⑱	End spacer	Special resin	
⑲	End clamp	Stainless steel	Rubber lining ($\varnothing 25$ to $\varnothing 40$)
⑳	Cam follower cap	Special resin	($\varnothing 25$ to $\varnothing 40$)
㉑	Cam follower		
㉒	Eccentric gear	Stainless steel	
㉓	Gear bracket	Stainless steel	
㉔	Adjustment gear	Stainless steel	
㉕	Snap ring	Stainless steel	

No.	Description	Material	Note
㉖	End Cover	Special resin	
㉘	Backup plate	Special resin	
㉙	Stopper	Carbon steel	Nickel plated
㉚	Spacer	Stainless steel	
㉛	Spring pin	Carbon tool steel	Black zinc chromated
㉜	Parallel pin	Stainless steel	
㉝	Hexagon socket head set screw	Chromium molybdenum steel	Black zinc chromated
㉞	Hexagon socket head cap screw	Chromium molybdenum steel	Nickel plated
㉟	Hexagon socket button head screw	Chromium molybdenum steel	Nickel plated
㊱	Hexagon socket head set screw	Chromium molybdenum steel	Black zinc chromated/Nickel plated
㊲	Round head Phillips screw	Chromium molybdenum steel	Nickel plated
㊳	Hexagon socket head taper plug	Carbon steel	Nickel plated
㊴	Magnet	Rare earth magnet	
㊵	Magnet holder	Special resin	
㊶	Hexagon socket head cap screw	Chromium molybdenum steel	Nickel plated
㊷	Hexagon socket head taper plug	Carbon steel	Nickel plated
㊸	Type CR retaining ring	Spring steel	
㊹	Head plate	Aluminum alloy	Hard anodized ($\varnothing 63$)
㊺	Side scraper	Special resin	($\varnothing 50$ to $\varnothing 63$)
㊻	Bushing	Aluminum alloy	($\varnothing 16$ to $\varnothing 20$)
㊼	Port cover	Special resin	($\varnothing 25$ to $\varnothing 40$)
㊽	Felt B	Felt	($\varnothing 16$ to $\varnothing 20$)

Seal List

No.	Description	Material	Qty.	MY1C16	MY1C20	MY1C25	MY1C32	MY1C40	MY1C50	MY1C63
⑮	Seal belt	Special resin	1	MY16-16A-Stroke	MY20-16A-Stroke	MY25-16A-Stroke	MY32-16A-Stroke	MY40-16A-Stroke	MY50-16A-Stroke	MY63-16A-Stroke
⑯	Dust seal band	Stainless steel	1	MY16-16B-Stroke	MY20-16B-Stroke	MY25-16B-Stroke	MY32-16B-Stroke	MY40-16B-Stroke	MY50-16B-Stroke	MY63-16B-Stroke
㉗	Scraper	NBR	2	MYM16-15AK0500	MYM20-15AK0501	MYM25-15AA5903	MYM32-15AA5904	MYM40-15AA5905	MYM50-15AK0502	MYM63-15AK0503
㉘	Piston seal	NBR	2	GM Y16	GM Y20	GM Y25	GM Y32	GM Y40	GM Y50	GM Y63
㉙	Cushion seal	NBR	2	MYB16-15-A7163	MYB20-15-A7164	RCS-8	RCS-10	RCS-12	MC-16	MC-20
㉚	Tube gasket	NBR	2	P12	P16	TMY-25	TMY-32	TMY-40	P44	P53
㉛	O-ring	NBR	2	$\varnothing 4 \times \varnothing 1.8 \times \varnothing 1.1$	$\varnothing 5.1 \times \varnothing 3 \times \varnothing 1.05$	$\varnothing 5.1 \times \varnothing 3 \times \varnothing 1.05$	$\varnothing 7.15 \times \varnothing 3.75 \times \varnothing 1.7$	$\varnothing 8.3 \times \varnothing 4.5 \times \varnothing 1.9$	C-4	C-4
㉜	O-ring	NBR	4	$\varnothing 7 \times \varnothing 4 \times \varnothing 1.5$	$\varnothing 7 \times \varnothing 4 \times \varnothing 1.5$	C-6	C-7	C-9	C-11.2	C-14
㉝	Side scraper	Special resin	2	—	—	—	—	—	MYM50-15CK0502B	MYM63-15CK0503B

Note) Two types of dust seal bands are available. Verify the type to use, since the part number varies depending on the treatment of the hexagon socket head set screw ④. (A) Black zinc chromated → MY□□-16B-Stroke (B) Nickel plated → MY□□-16BW-Stroke

Series MY1H

High Precision Guide Type

ø10, ø16, ø20, ø25, ø32, ø40

MX□

MTS

MY□

CY□

MG□

CX□

D-

-X

20-

Data

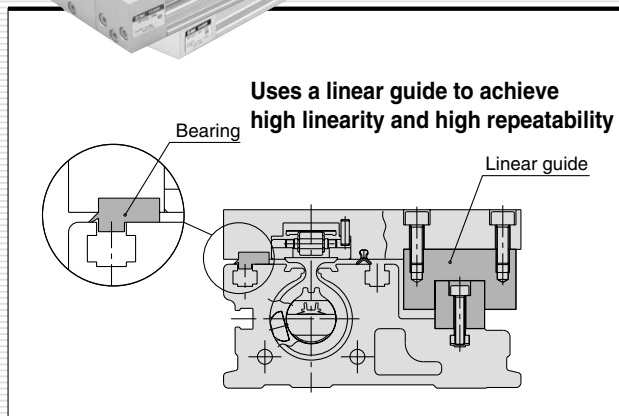
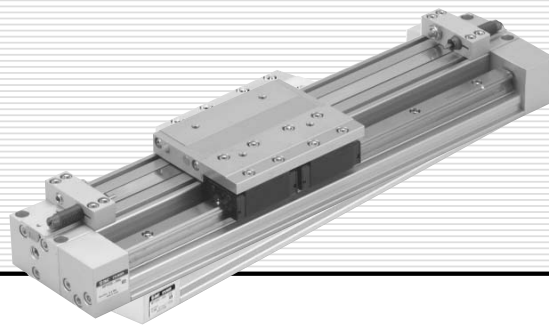

End lock type capable of holding a position at the stroke end (Except bore size ø10)



Series MY1H

Before Operation

Maximum Allowable Moment/Maximum Load Weight

Model	Bore size (mm)	Maximum allowable moment (N·m)			Maximum load weight (kg)		
		M ₁	M ₂	M ₃	m ₁	m ₂	m ₃
MY1H	10	0.8	1.1	0.8	6.1	6.1	6.1
	16	3.7	4.9	3.7	10.8	10.8	10.8
	20	11	16	11	17.6	17.6	17.6
	25	23	26	23	27.5	27.5	27.5
	32	39	50	39	39.2	39.2	39.2
	40	50	50	39	50	50	50

The above values are the maximum allowable values for moment and load. Refer to each graph regarding the maximum allowable moment and maximum allowable load for a particular piston speed.

Maximum Allowable Moment

Select the moment from within the range of operating limits shown in the graphs. Note that the maximum allowable load value may sometimes be exceeded even within the operating limits shown in the graphs. Therefore, also check the allowable load for the selected conditions.

Load weight (kg)

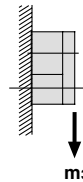
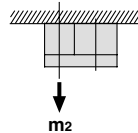
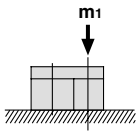

Moment (N·m)

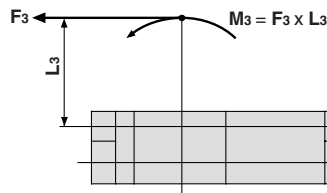
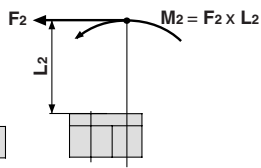
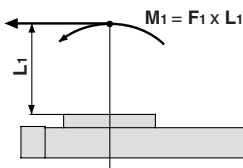

<Calculation of guide load factor>

1. Maximum allowable load (1), static moment (2), and dynamic moment (3) (at the time of impact with stopper) must be examined for the selection calculations.

* To evaluate, use \bar{v} (average speed) for (1) and (2), and v (collision speed $v = 1.4\bar{v}$) for (3). Calculate m_{max} for (1) from the maximum allowable load graph (m_1, m_2, m_3) and M_{max} for (2) and (3) from the maximum allowable moment graph (M_1, M_2, M_3).

$$\text{Sum of guide load factors } \Sigma\alpha = \frac{\text{Load weight [m]}}{\text{Maximum allowable load [m}_{max}\text{]}} + \frac{\text{Static moment [M]}^{(1)}}{\text{Allowable static moment [M}_{max}\text{]}} + \frac{\text{Dynamic moment [M}_E\text{]}^{(2)}}{\text{Allowable dynamic moment [M}_{Emax}\text{]}} \leq 1$$

Note 1) Moment caused by the load, etc., with cylinder in resting condition.

Note 2) Moment caused by the impact load equivalent at the stroke end (at the time of impact with stopper).

Note 3) Depending on the shape of the workpiece, multiple moments may occur. When this happens, the sum of the load factors ($\Sigma\alpha$) is the total of all such moments.

2. Reference formula [Dynamic moment at impact]

Use the following formulae to calculate dynamic moment when taking stopper impact into consideration.

m: Load weight (kg)

F: Load (N)

F_E: Load equivalent to impact (at impact with stopper) (N)

\bar{v} : Average speed (mm/s)

M: Static moment (N·m)

$$v = 1.4\bar{v} \quad F_E = 1.4\bar{v} \cdot \delta \cdot m \cdot g$$

$$\therefore M_E = \frac{1}{3} \cdot F_E \cdot L_1 = 4.57\bar{v} \delta m L_1 \quad (\text{N}\cdot\text{m})$$

v : Collision speed (mm/s)

L₁: Distance to the load's center of gravity (m)

M_E: Dynamic moment (N·m)

δ : Damper coefficient

With rubber bumper = 4/100

(MY1B10, MY1H10)

With air cushion = 1/100

With shock absorber = 1/100

g: Gravitational acceleration (9.8 m/s²)

Note 4) $1.4\bar{v}\delta$ is a dimensionless coefficient for calculating impact force.

Note 5) Average load coefficient ($=\frac{1}{3}$): This coefficient is for averaging the maximum load moment at the time of stopper impact according to service life calculations.

3. For detailed selection procedures, refer to pages 8-11-70 to 8-11-71.

Maximum Load Weight

Select the load from within the range of limits shown in the graphs. Note that the maximum allowable moment value may sometimes be exceeded even within the operating limits shown in the graphs. Therefore, also check the allowable moment for the selected conditions.

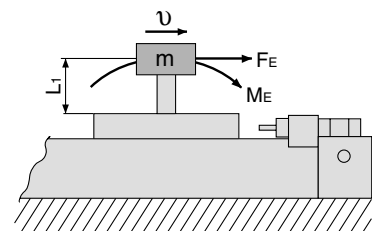

Mechanically Jointed Rodless Cylinder High Precision Guide Type Series MY1H

MY1H/M₁

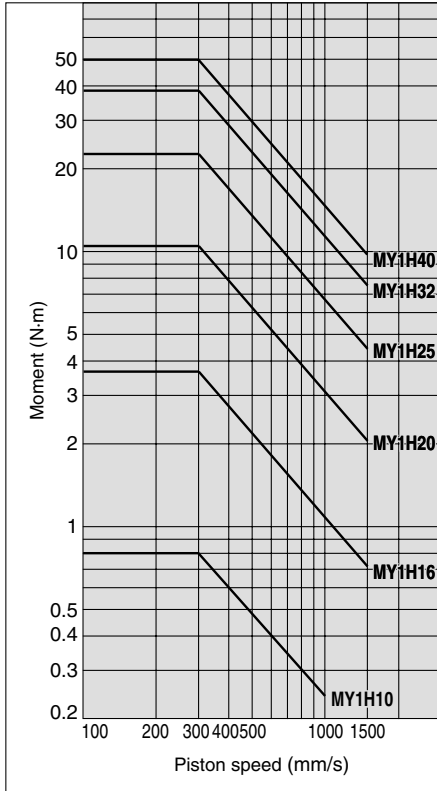

MY1H/M₂

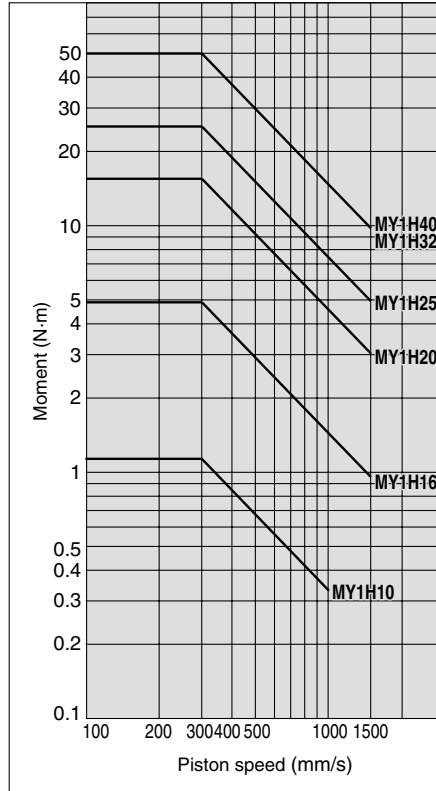

MY1H/M₃

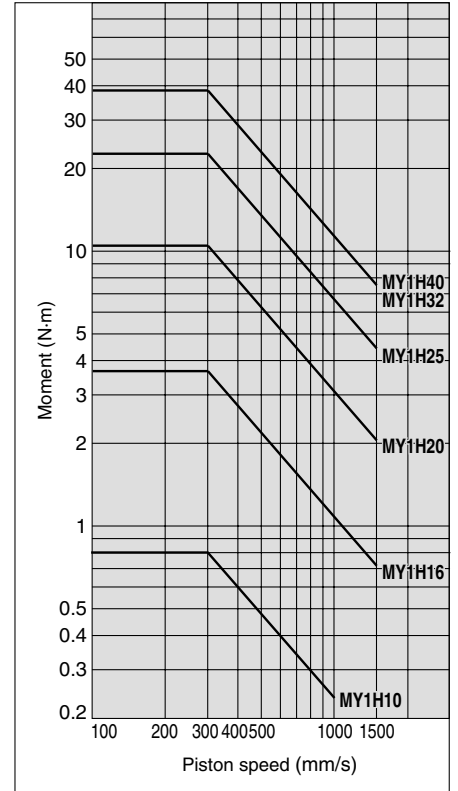

MX

MTS

MY

CY

MG

CX

D-

-X

20-

Data

MY1H/m₁

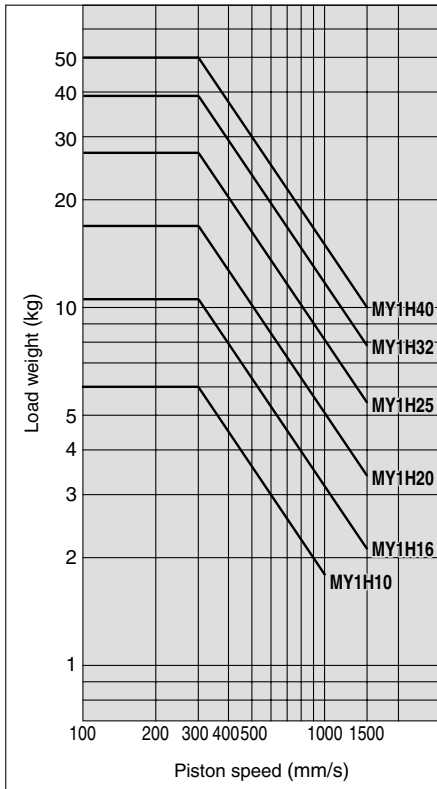

MY1H/m₂

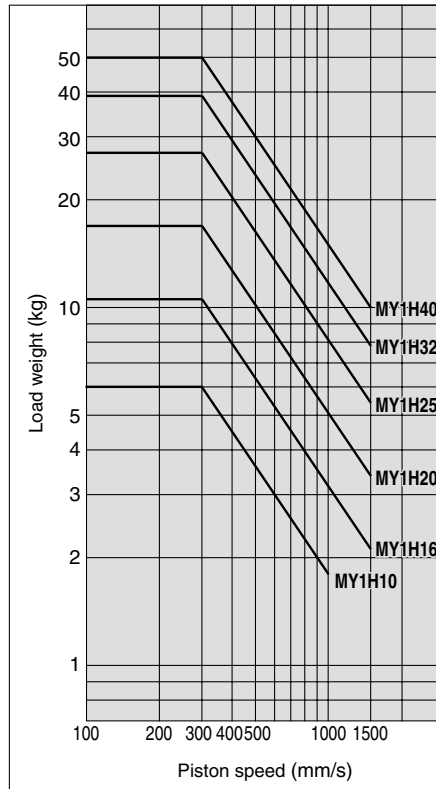

MY1H/m₃

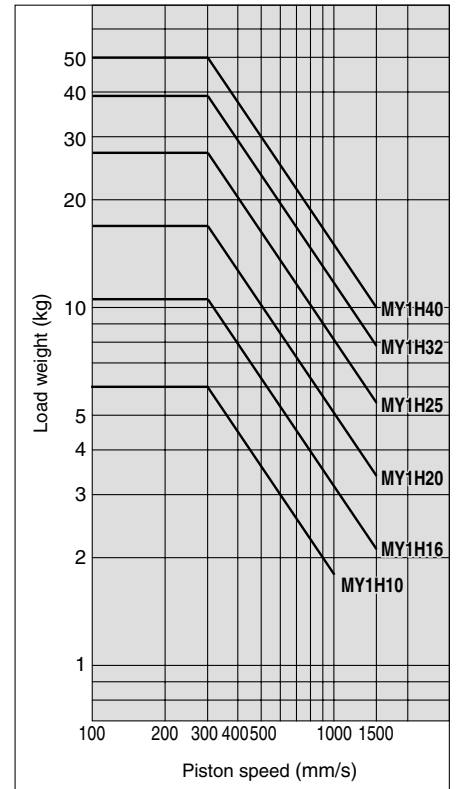

Model Selection

Following are the steps for selecting the most suitable Series MY1H to your application.

Calculation of Guide Load Factor

1. Operating Conditions

- Operating cylinder MY1H40-500
- Average operating speed v_a ... 300 mm/s
- Mounting orientation Wall mounting
- Cushion Air cushion ($\delta = 1/100$)

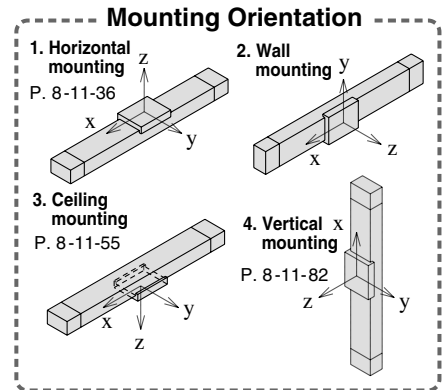
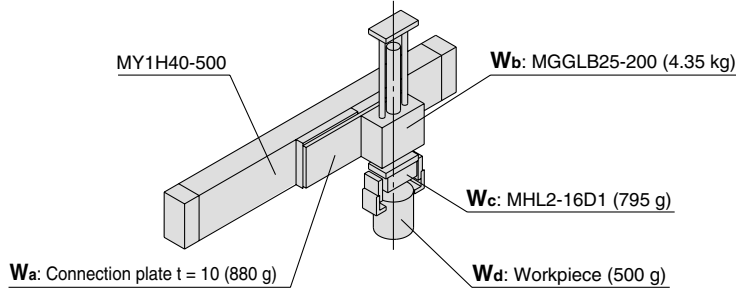

For actual examples of calculation for each orientation, refer to the pages above.

2. Load Blocking

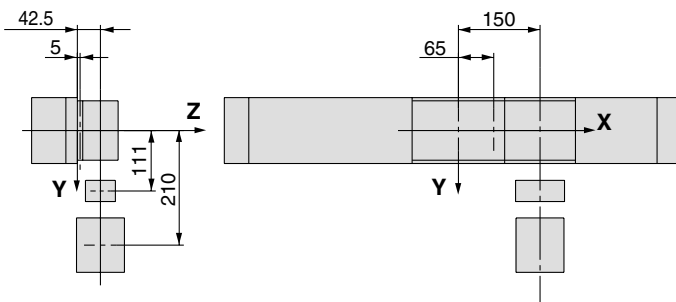

Weight and Center of Gravity for Each Workpiece

Workpiece no. W_n	Weight m_n	Center of gravity		
		X-axis X_n	Y-axis Y_n	Z-axis Z_n
W_a	0.88 kg	65 mm	5 mm	0 mm
W_b	4.35 kg	150 mm	42.5 mm	0 mm
W_c	0.795 kg	150 mm	42.5 mm	111 mm
W_d	0.5 kg	150 mm	42.5 mm	210 mm

$n = a, b, c, d$

3. Composite Center of Gravity Calculation

$$m_3 = \sum m_n = 0.88 + 4.35 + 0.795 + 0.5 = 6.525 \text{ kg}$$

$$X = \frac{1}{m_3} \times \sum (m_n \times X_n) = \frac{1}{6.525} (0.88 \times 65 + 4.35 \times 150 + 0.795 \times 150 + 0.5 \times 150) = 138.5 \text{ mm}$$

$$Y = \frac{1}{m_3} \times \sum (m_n \times Y_n) = \frac{1}{6.525} (0.88 \times 0 + 4.35 \times 0 + 0.795 \times 111 + 0.5 \times 210) = 29.6 \text{ mm}$$

$$Z = \frac{1}{m_3} \times \sum (m_n \times Z_n) = \frac{1}{6.525} (0.88 \times 5 + 4.35 \times 42.5 + 0.795 \times 42.5 + 0.5 \times 42.5) = 37.4 \text{ mm}$$

4. Calculation of Load Factor for Static Load

m_3 : Weight

m_{3max} (from (1) of graph MY1H/ m_3) = 50 (kg).....

$$\text{Load factor } \alpha_1 = m_3/m_{3max} = 6.525/50 = 0.13$$

M_2 : Moment

m_{2max} (from (2) of graph MY1H/ M_2) = 50 (N·m).....

$$M_2 = m_3 \times g \times Z = 6.525 \times 9.8 \times 37.4 \times 10^{-3} = 2.39 \text{ (N·m)}$$

$$\text{Load factor } \alpha_2 = M_2/M_{2max} = 2.39/50 = 0.05$$

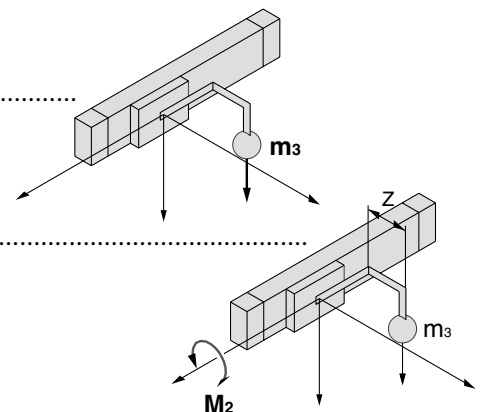

M₃: Moment

M_{3max} (from (3) of graph MY1H/M₃) = 38.7 (N·m).....

M₃ = m₃ × g × X = 6.525 × 9.8 × 138.5 × 10⁻³ = 8.86 (N·m)

Load factor α₃ = M₃/M_{3max} = 8.86/38.7 = **0.23**

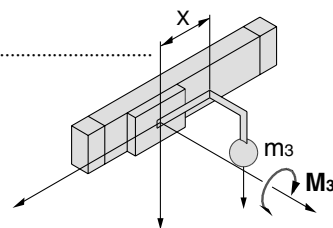

5. Calculation of Load Factor for Dynamic Moment

Equivalent load F_E at impact

F_E = 1.4V_a × δ × m × g = 1.4 × 300 × $\frac{1}{100}$ × 6.525 × 9.8 = 268.6 (N)

M_{1E}: Moment

M_{1Emax} (from (4) of graph MY1H/M₁ where 1.4V_a = 420 mm/s) = 35.9 (N·m).....

M_{1E} = $\frac{1}{3}$ × F_E × Z = $\frac{1}{3}$ × 268.6 × 37.4 × 10⁻³ = 3.35 (N·m)

Load factor α₄ = M_{1E}/M_{1Emax} = 3.35/35.9 = **0.09**

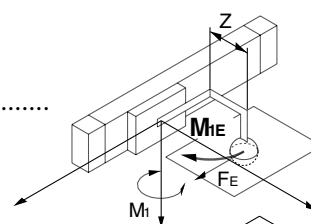

M_{3E}: Moment

M_{3Emax} (from (5) of graph MY1H/M₃ where 1.4V_a = 420 mm/s) = 27.6 (N·m).....

M_{3E} = $\frac{1}{3}$ × F_E × Y = $\frac{1}{3}$ × 268.6 × 29.6 × 10⁻³ = 2.65 (N·m)

Load factor α₅ = M_{3E}/M_{3Emax} = 2.65/27.6 = **0.10**

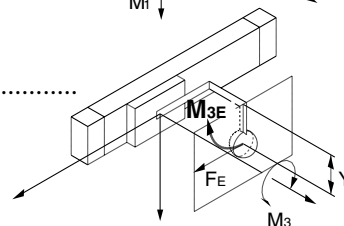

6. Sum and Examination of Guide Load Factors

Σα = α₁ + α₂ + α₃ + α₄ + α₅ = **0.60 ≤ 1**

The above calculation is within the allowable value, and therefore the selected model can be used.

Select a shock absorber separately.

In an actual calculation, when the total sum of guide load factors Σα in the formula above is more than 1, consider either decreasing the speed, increasing the bore size, or changing the product series.

This calculation can be easily made using the “SMC Pneumatics CAD System”.

Load Weight

MY1H/m₃

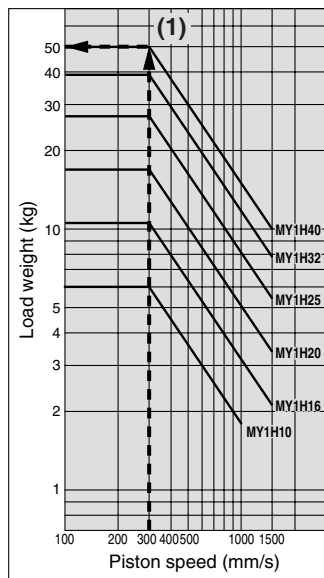

Allowable Moment

MY1H/M₁

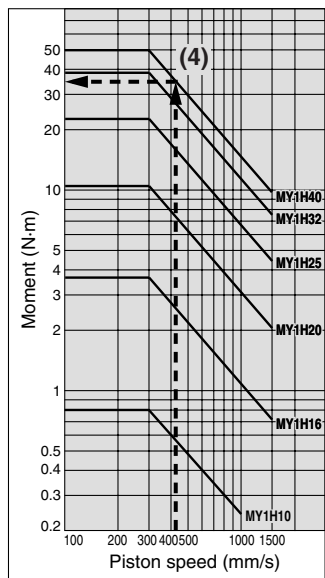

MY1H/M₂

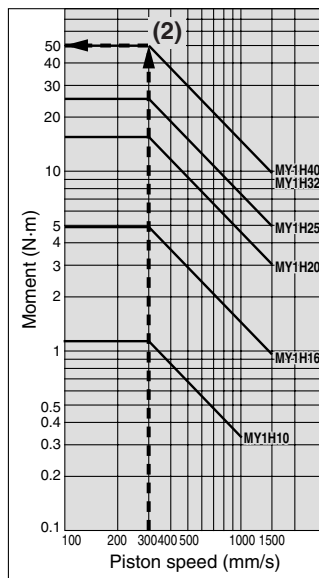

MY1H/M₃

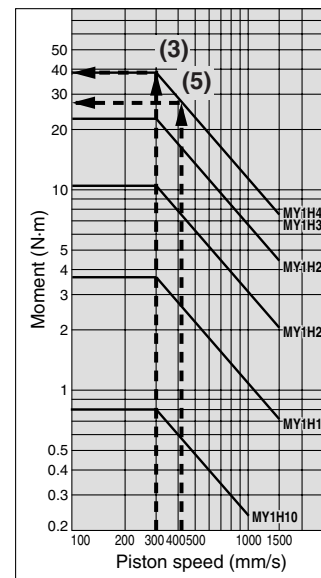

MX	<input type="checkbox"/>
MTS	<input type="checkbox"/>
MY	<input checked="" type="checkbox"/>
CY	<input type="checkbox"/>
MG	<input type="checkbox"/>
CX	<input type="checkbox"/>
D-	<input type="checkbox"/>
-X	<input type="checkbox"/>
20-	<input type="checkbox"/>
Data	<input type="checkbox"/>



Mechanically Jointed Rodless Cylinder High Precision Guide Type

Series MY1H

ø10, ø16, ø20, ø25, ø32, ø40

How to Order

MY1H 25 300 Y7BW

High precision guide type

Bore size (mm)

10	10 mm
16	16 mm
20	20 mm
25	25 mm
32	32 mm
40	40 mm

Piping

Nil	Standard type
G	Centralized piping type

Note) For ø10, only G is available.

Stroke

Refer to "Standard Stroke" on page 8-11-73.

Stroke adjusting unit

Nil	Without adjusting unit
A	With adjusting bolt
L	With low load shock absorber + Adjusting bolt
H	With high load shock absorber + Adjusting bolt
AL	With one A unit and one L unit
AH	With one A unit and one H unit each
LH	With one L unit and one H unit each

Note) MY1H16 is not available with H unit.
MY1H10 is not available with A and L units.

Number of auto switches

Nil	2 pcs
S	1 pcs
n	"n" pcs

Auto switch

Nil	Without auto switch
-----	---------------------

* For the applicable auto switch model, refer to the table below.
* Auto switches are shipped together, (but not assembled)

End lock position

Nil	Without end lock
E	Right end
F	Left end
W	Both ends

* MY1H10 is not available with end lock.
* For end lock positions, refer to page 8-11-83.

Suffix for stroke adjusting unit

Nil	Both ends
S	One end

Note) "S" is applicable for stroke adjusting units A, L and H.

Shock Absorbers for L and H Units

Bore size (mm)	10	16	20	25	32	40
L unit	—	RB0806	RB1007	RB1412	RB1412	—
H unit	RB0805	—	RB1007	RB1412	RB2015	—

Applicable Auto Switch/Refer to page 8-30-1 for further information on auto switches.

For ø10, ø16, ø20

Type	Special function	Electrical entry	Indicator light	Wiring (Output)	Load voltage			Auto switch model		Lead wire length (m)*			Pre-wire connector	Applicable load	
					DC	AC	AC	Perpendicular	In-line	0.5 (Nil)	3 (L)	5 (Z)		IC circuit	Relay, PLC
Reed switch	—	Grommet	Yes	3-wire (NPN equivalent)	—	5 V	—	A96V	A96	●	●	—	—	—	—
				2-wire	24 V	12 V	100 V	A93V	A93	●	●	—	—	—	Relay, PLC
Solid state switch	Diagnostic indication (2-color indication)	Grommet	Yes	3-wire (NPN)	24 V	5 V, 12 V	—	M9NV	M9N	●	●	○	○	—	IC circuit
				3-wire (PNP)				M9PV	M9P	●	●	○	○	—	Relay, PLC
				2-wire				M9BV	M9B	●	●	○	○	—	—
				3-wire (NPN)				F9NWV	F9NW	●	●	○	○	—	IC circuit
				3-wire (PNP)				F9PWV	F9PW	●	●	○	○	—	—
				2-wire				F9BWV	F9BW	●	●	○	○	—	—

For ø25, ø32, ø40

Type	Special function	Electrical entry	Indicator light	Wiring (Output)	Load voltage			Auto switch model		Lead wire length (m)*			Pre-wire connector	Applicable load	
					DC	AC	AC	Perpendicular	In-line	0.5 (Nil)	3 (L)	5 (Z)		IC circuit	Relay, PLC
Reed switch	—	Grommet	Yes	3-wire (NPN equivalent)	—	5 V	—	—	Z76	●	●	—	—	—	—
				2-wire	24 V	12 V	100 V	—	Z73	●	●	●	—	—	Relay, PLC
Solid state switch	Diagnostic indication (2-color indication)	Grommet	Yes	3-wire (NPN)	24 V	5 V, 12 V	—	Y69A	Y59A	●	●	○	○	—	IC circuit
				3-wire (PNP)				Y7PV	Y7P	●	●	○	○	—	Relay, PLC
				2-wire				Y69B	Y59B	●	●	○	○	—	—
				3-wire (NPN)				Y7NWV	Y7NW	●	●	○	○	—	IC circuit
				3-wire (PNP)				Y7PWV	Y7PW	●	●	○	○	—	—
				2-wire				Y7BWV	Y7BW	●	●	○	○	—	—

* Lead wire length symbols: 0.5 m.....Nil (Example) A93
3 m.....L (Example) Y59BL
5 m.....Z (Example) F9NWZ

* Solid state switches marked with "○" are produced upon receipt of order.

- There are other applicable auto switches than listed above. For details, refer to page 8-11-101.
- For details about auto switches with pre-wire connector, refer to page 8-30-52.

Mechanically Jointed Rodless Cylinder High Precision Guide Type Series MY1H

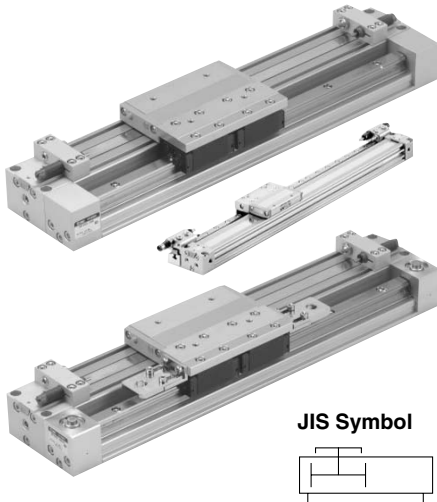

Specifications

Bore size (mm)		10	16	20	25	32	40
Fluid		Air					
Action		Double acting					
Operating pressure range		0.2 to 0.8 MPa (2.0 to 8.2 kgf/cm ²)		0.1 to 0.8 MPa			
Proof pressure		1.2 MPa					
Ambient and fluid temperature		5 to 60°C					
Cushion		Rubber bumper		Air cushion			
Lubrication		Non-lube					
Stroke length tolerance		+1.8 0					
Piping port size	Front/Side port	M5 x 0.8			Rc 1/8		Rc 1/4
	Bottom port	ø4		ø5		ø6	

MX MTS MY CY MG CX D- -X 20- Data

Stroke Adjusting Unit Specifications

Bore size (mm)	10			16			20			25			32			40		
Unit symbol	H	A	L	A	L	H	A	L	H	A	L	H	A	L	H			
Configuration Shock absorber model	RB 0805 with adjusting bolt	With adjusting bolt	RB 0806 with adjusting bolt	With adjusting bolt	RB 0806 with adjusting bolt	RB 0807 with adjusting bolt	With adjusting bolt	RB 1007 with adjusting bolt	RB 1412 with adjusting bolt	With adjusting bolt	RB 1412 with adjusting bolt	RB 2015 with adjusting bolt	With adjusting bolt	RB 1412 with adjusting bolt	RB 2015 with adjusting bolt			
Fine stroke adjustment range (mm)	0 to -10			0 to -5.6			0 to -6			0 to -11.5			0 to -12			0 to -16		
Stroke adjustment range	When exceeding the stroke fine adjustment range: Utilize a made-to-order specifications "-X416" and "-X417".																	

Shock Absorber Specifications

Model	RB 0805	RB 0806	RB 1007	RB 1412	RB 2015
Max. energy absorption (J)	1.0	2.9	5.9	19.6	58.8
Stroke absorption (mm)	5	6	7	12	15
Max. collision speed (mm/s)	1000	1500	1500	1500	1500
Max. operating frequency (cycle/min)	80	80	70	45	25
Spring force (N)	Extended	1.96	1.96	4.22	6.86
	Retracted	3.83	4.22	6.86	15.98
Operating temperature range (°C)	5 to 60				

Piston Speed

Bore size (mm)		10	16 to 40
Without stroke adjusting unit		100 to 500 mm/s	100 to 1000 mm/s
Stroke adjusting unit	A unit	100 to 200 mm/s	100 to 1000 mm/s ⁽¹⁾
	L unit and H unit	100 to 1000 mm/s	100 to 1500 mm/s ⁽²⁾

Note 1) Be aware that when the stroke adjusting range is increased by manipulating the adjusting bolt, the air cushion capacity decreases. Also, when exceeding the air cushion stroke ranges on page 8-11-77, the piston speed should be 100 to 200 mm per second.

Note 2) The piston speed is 100 to 1000 mm/s for centralized piping.

Note 3) Use at a speed within the absorption capacity range. Refer to page 8-11-77.

Standard Stroke

Bore size (mm)	Standard stroke * (mm)	Maximum manufacturable stroke (mm)
10, 16, 20	50, 100, 150, 200 250, 300, 350, 400	1000
25, 32, 40	450, 500, 550, 600	1500

* Strokes are manufacturable in 1 mm increments, up to the maximum stroke. However, add "-XB10" to the end of the part number for non-standard strokes from 51 to 599. Also when exceeding a 600 mm stroke, specify "-XB11" at the end of the model number. (Except ø10)

Lock Specifications

Bore size (mm)	16	20	25	32	40
Lock position	One end (Selectable), Both ends				
Holding force (Max.) (N)	110	170	270	450	700
Fine stroke adjusting range (mm)	0 to -5.6	0 to -6	0 to -11.5	0 to -12	0 to -16
Backlash	1 mm or less				
Manual release	Possible (Non-lock type)				



Made to Order Specifications (For details, refer to page 8-31-1.)

Symbol	Specifications
-XB10	Intermediate stroke (Using exclusive body)
-XB11	Long stroke
-XC18	NPT finish piping port
-XC56	With knock pin hole
-XC67	NBR rubber lining in dust seal band
-X168	Helical insert thread specifications
-X416	Holder mounting bracket I
-X417	Holder mounting bracket II

Series MY1H

Theoretical Output (N)

Bore size (mm)	Piston area (mm ²)	Operating pressure (MPa)							
		0.2	0.3	0.4	0.5	0.6	0.7	0.8	
10	78	15	23	31	39	46	54	62	
16	200	40	60	80	100	120	140	160	
20	314	62	94	125	157	188	219	251	
25	490	98	147	196	245	294	343	392	
32	804	161	241	322	402	483	563	643	
40	1256	251	377	502	628	754	879	1005	

Note) Theoretical output (N) = Pressure (MPa) x Piston area (mm²)

Weight (kg)

Bore size (mm)	Basic weight	Additional weight per each 50mm of stroke	Side support weight (per set)	Stroke adjusting unit weight (per unit)		
			Type A and B	A unit weight	L unit weight	H unit weight
10	0.26	0.08	0.003	—	—	0.02
16	0.74	0.14	0.01	0.02	0.04	—
20	1.35	0.25	0.02	0.03	0.05	0.07
25	2.31	0.30	0.02	0.04	0.07	0.11
32	4.65	0.46	0.04	0.08	0.14	0.23
40	6.37	0.55	0.08	0.12	0.19	0.28

Calculation: (Example) MY1H25-300A

- Basic weight 2.31 kg
 - Additional weight 0.30/50 st
 - Weight of A unit 0.06 kg
 - Cylinder stroke.....300 st
- $$2.31 + 0.30 \times 300 \div 50 + 0.04 \times 2 = 4.19 \text{ kg}$$

Option

Stroke Adjusting Unit Part No.

Bore (mm)	10	16	20
A unit	—	MYH-A16A	MYH-A20A
L unit	—	MYH-A16L	MYH-A20L
H unit	MYH-A10H	—	MYH-A20H

Bore (mm)	25	32	40
A unit	MYH-A25A	MYH-A32A	MYH-A40A
L unit	MYH-A25L	MYH-A32L	MYH-A40L
H unit	MYH-A25H	MYH-A32H	MYH-A40H

Side Support Part No.

Bore (mm)	10	16	20
Side support A	MY-S10A	MY-S16A	MY-S20A
Side support B	MY-S10B	MY-S16B	MY-S20B

Bore (mm)	25	32	40
Side support A	MY-S25A	MY-S32A	MY-S40A
Side support B	MY-S25B	MY-S32B	MY-S40B

For details about dimensions, etc., refer to page 8-11-84.

⚠ Precautions

Be sure to read before handling.
For Safety Instructions and Actuator Precautions,
refer to pages 8-34-3 to 8-34-6.

⚠ Caution

Use caution not to get your hands caught in the unit.

- When using a product with stroke adjusting unit, the space between the slide table (slider) and the stroke adjusting unit becomes narrow at the stroke end, causing a danger of hands getting caught. Install a protective cover to prevent direct contact with the human body.

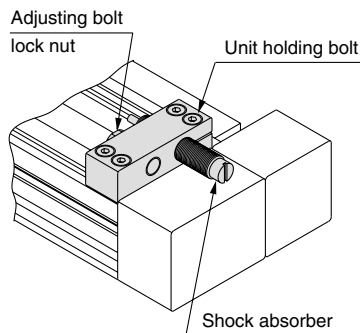

<Fastening of unit>

The unit can be secured by evenly tightening the four unit holding bolts.

⚠ Caution

Do not operate with the stroke adjusting unit fixed in an intermediate position.

When the stroke adjusting unit is fixed in an intermediate position, slippage can occur depending on the amount of energy released at the time of an impact. In such cases, the use of the adjusting bolt mounting brackets, available per made-to-order specifications -X416 and -X417, is recommended. (Except $\phi 10$)

For other lengths, please consult with SMC (Refer to "Tightening Torque for Stroke Adjusting Unit Holding Bolts".)

<Stroke adjustment with adjusting bolt>

Loosen the adjusting bolt lock nut, and adjust the stroke from the head cover side using a hexagon wrench. Re-tighten the lock nut.

<Stroke adjustment with shock absorber>

Loosen the two unit holding bolts on the shock absorber side, turn the shock absorber and adjust the stroke. Then, uniformly tighten the unit holding bolts to secure the shock absorber.

Take care not to over-tighten the holding bolts. (Except $\phi 10$, $\phi 16$, $\phi 20$) (Refer to "Tightening Torque for Stroke Adjusting Unit Holding Bolts".)

⚠ Caution

To adjust the stroke adjusting unit of the MY1H10, follow the step shown below.

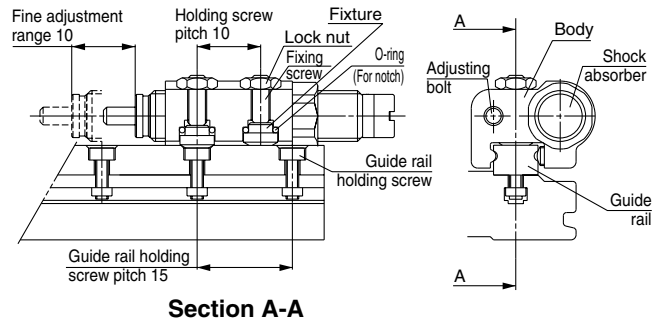

Adjusting Procedure

- Loosen the two lock nuts, and then loosen the holding screws by turning them approximately two turns.
- Move the body to the notch just before the desired stroke. (The notches are found in alternating increments of 5 mm and 10 mm.)
- Tighten the holding screw to 0.3 N·m. Make sure that the tightening does not cause excessive torque. The fixture fits into the fastening hole in the guide rail to prevent slippage, which enables fastening with low torque.
- Tighten the lock nut to 0.6 N·m.
- Make fine adjustments with the adjusting bolt and shock absorber.

MX

MTS

MY

CY

MG

CX

D-

-X

20-

Data

⚠ Precautions

With End Locks

Recommended Pneumatic Circuit

⚠ Caution

This is necessary for the correct locking and unlocking actions.

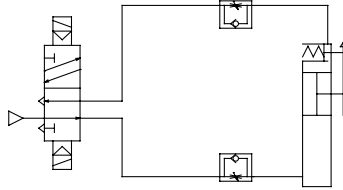

Operating Precautions

⚠ Caution

1. Do not use 3 position solenoid valves.

Avoid use in combination with 3 position solenoid valves (especially closed center metal seal types). If pressure is trapped in the port on the lock mechanism side, the cylinder cannot be locked.

Furthermore, even after being locked, the lock may be released after some time due to air leaking from the solenoid valve and entering the cylinder.

2. Back pressure is required when releasing the lock.

Before starting operation, be sure to control the system so that air is supplied to the side without the lock mechanism (in case of locks on both ends, the side where the slide table is not locked) as shown in the figure above. There is a possibility that the lock may not be released. (Refer to the section on releasing the lock.)

3. Release the lock when mounting or adjusting the cylinder.

If mounting or other work is performed when the cylinder is locked, the lock unit may be damaged.

4. Operate at 50% or less of the theoretical output.

If the load exceeds 50% of the theoretical output, this may cause problems such as failure of the lock to release, or damage to the lock unit.

5. Do not operate multiple cylinders in synchronization.

Avoid applications in which two or more end lock cylinders are synchronized to move one workpiece, as one of the cylinder locks may not be able to release when required.

6. Use a speed controller with meter-out control.

Lock cannot be released occasionally by meter-in control.

7. Be sure to operate completely to the cylinder stroke end on the side with the lock.

If the cylinder piston does not reach the end of the stroke, locking and unlocking may not be possible. (Refer to the section on adjusting the end lock mechanism.)

Operating Pressure

⚠ Caution

1. Supply air pressure of 0.15 MPa or higher to the port on the side that has the lock mechanism, as it is necessary for disengaging the lock.

Exhaust Speed

⚠ Caution

1. Locking will occur automatically if the pressure applied to the port on the lock mechanism side falls to 0.05 MPa or less. In the cases where the piping on the lock mechanism side is long and thin, or the speed controller is separated at some distance from the cylinder port, the exhaust speed will be reduced. Take note that some time may be required for the lock to engage. In addition, clogging of a silencer mounted on the solenoid valve exhaust port can produce the same effect.

Relation to Cushion

⚠ Caution

1. When the air cushion on the lock mechanism side is in a fully closed or nearly closed state, there is a possibility that the slide table will not reach the stroke end, in which case locking will not occur.

Adjusting the End Lock Mechanism

⚠ Caution

1. The end lock mechanism is adjusted at the time of shipping. Therefore, adjustment for operation at the stroke end is unnecessary.
2. Adjust the end lock mechanism after the stroke adjusting unit has been adjusted. The adjusting bolt and shock absorber of the stroke adjusting unit must be adjusted and secured first. Locking and unlocking may not occur otherwise.
3. Perform fine adjustment of the end lock mechanism as follows. Loosen the lock finger holding bolts, and then adjust by aligning the center of the lock piston with the center of the lock finger hole. Secure the lock finger.

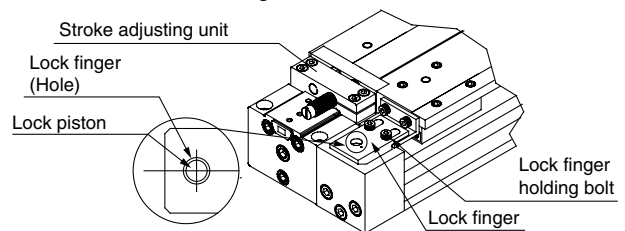

Releasing the Lock

⚠ Warning

1. Before releasing the lock, be sure to supply air to the side without the lock mechanism, so that there is no load applied to the lock mechanism when it is released. (Refer to the recommended pneumatic circuits.) If the lock is released when the port on the side without the lock is in an exhaust state, and with a load applied to the lock unit, the lock unit may be subjected to an excessive force and be damaged. Furthermore, sudden movement of the slide table is very dangerous.

Manual Release

⚠ Caution

1. When manually releasing the end lock, be sure to release the pressure. If it is unlocked while the air pressure still remains, it will lead to damage a workpiece, etc. due to unexpected lurching.
2. Perform manual release of the end lock mechanism as follows. Push the lock piston down with a screwdriver, etc., and move the slide table.

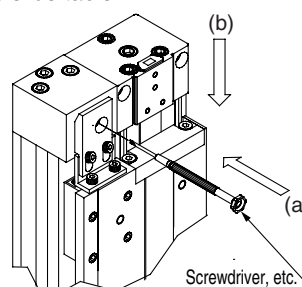

Other handling precautions regarding mounting, piping, and environment are the same as the standard series.

Cushion Capacity

Cushion Selection

<Rubber bumper>

Rubber bumpers are a standard feature on MY1H10.

Since the stroke absorption of rubber bumpers is short, when adjusting the stroke with an A unit, install an external shock absorber.

The load and speed range which can be absorbed by a rubber bumper is inside the rubber bumper limit line of the graph.

<Air cushion>

Air cushions are a standard feature on mechanically jointed rodless cylinders.

The air cushion mechanism is incorporated to prevent excessive impact of the piston at the stroke end during high speed operation. The purpose of air cushion, thus, is not to decelerate the piston near the stroke end.

The ranges of load and speed that air cushions can absorb are within the air cushion limit lines shown in the graphs.

<Stroke adjusting unit with shock absorber>

Use this unit when operating with a load or speed exceeding the air cushion limit line, or when cushioning is required outside of the effective air cushion stroke range due to stroke adjustment.

L unit

Use this unit when the cylinder stroke is outside of the effective air cushion range even if the load and speed are within the air cushion limit line, or when the cylinder is operated in a load and speed range above the air cushion limit line or below the L unit limit line.

H unit

Use this unit when the cylinder is operated in a load and speed range above the L unit limit line and below the H unit limit line.

⚠ Caution

1. Refer to the figure below when using the adjusting bolt to perform stroke adjustment.

When the effective stroke of the shock absorber decreases as a result of stroke adjustment, the absorption capacity decreases dramatically. Secure the adjusting bolt at the position where it protrudes approximately 0.5 mm from the shock absorber.

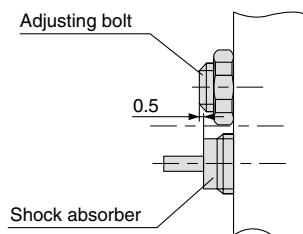

2. Do not use a shock absorber together with air cushion.

Air Cushion Stroke

(mm)

Bore size (mm)	Cushion stroke
16	12
20	15
25	15
32	19
40	24

Absorption Capacity of Rubber Bumper, Air cushion and Stroke Adjusting Units

MY1H10

Horizontal collision: P = 0.5 MPa

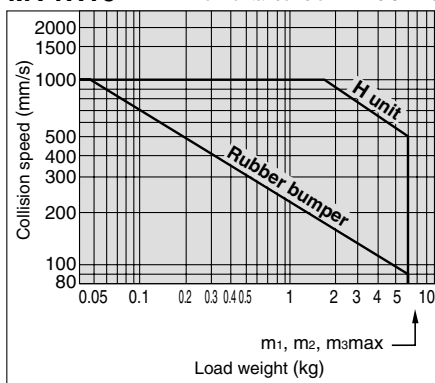

MY1H32

Horizontal collision: P = 0.5 MPa

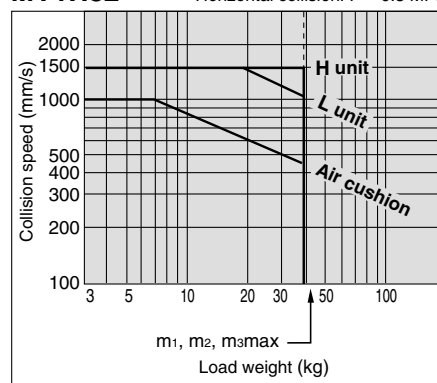

MY1H16

Horizontal collision: P = 0.5 MPa

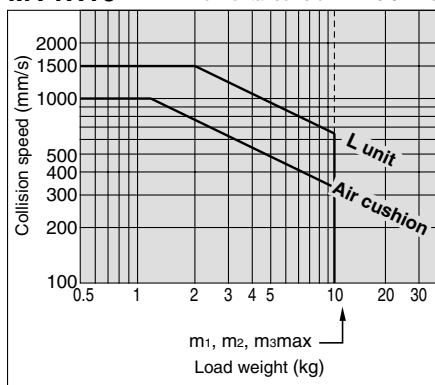

MY1H40

Horizontal collision: P = 0.5 MPa

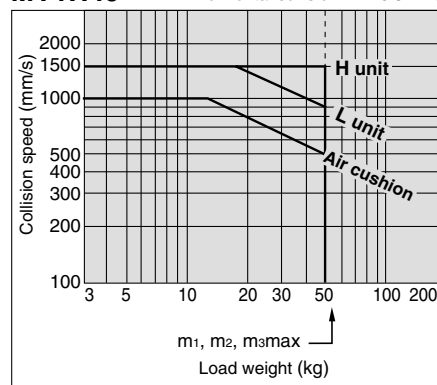

MY1H20

Horizontal collision: P = 0.5 MPa

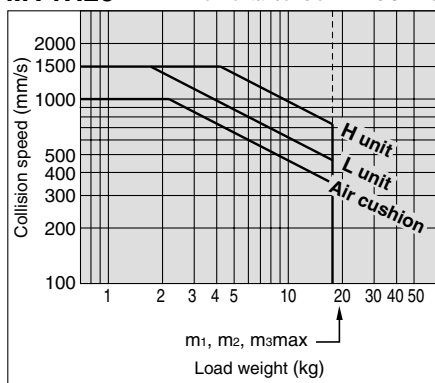

MY1H25

Horizontal collision: P = 0.5 MPa

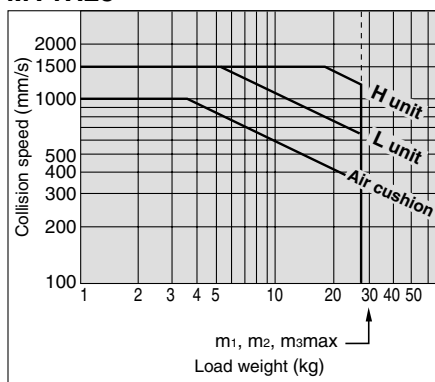

MX

MTS

MY

CY

MG

CX

D-

-X

20-

Data

Series MY1H

Cushion Capacity

Tightening Torque for Stroke Adjusting Unit Holding Bolts (N·m)

Bore size (mm)	Tightening torque
10	Refer to page XXX for unit adjusting procedure.
16	0.6
20	1.5
25	1.5
32	3.0
40	5.0

Calculation of Absorbed Energy for Stroke Adjusting Unit with Shock Absorber (N·m)

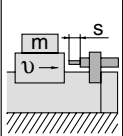
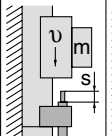
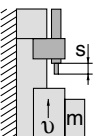
Type of impact	Horizontal collision	Vertical (Downward)	Vertical (Upward)
			
Kinetic energy E ₁	$\frac{1}{2} m \cdot v^2$		
Thrust energy E ₂	F · s	F · s + m · g · s	F · s - m · g · s
Absorbed energy E	E ₁ + E ₂		

Symbol

v: Speed of impact object (m/s)

F: Cylinder thrust (N)

s: Shock absorber stroke (m)

m: Weight of impact object (kg)

g: Gravitational acceleration (9.8 m/s²)

Note) The speed of the impact object is measured at the time of impact with the shock absorber.

Rubber Bumper (ø10 only) Positive Stroke from One End Due to Pressure

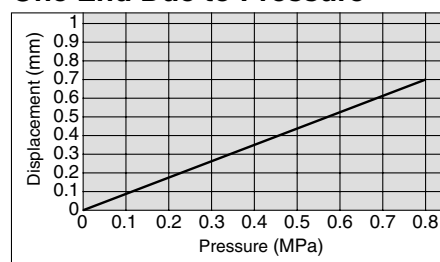

Series MY1H

Standard Type/Centralized Piping Type $\phi 16, \phi 20$

Refer to page 8-11-9 regarding centralized piping port variations.

MY1H16L□/20L□ — Stroke

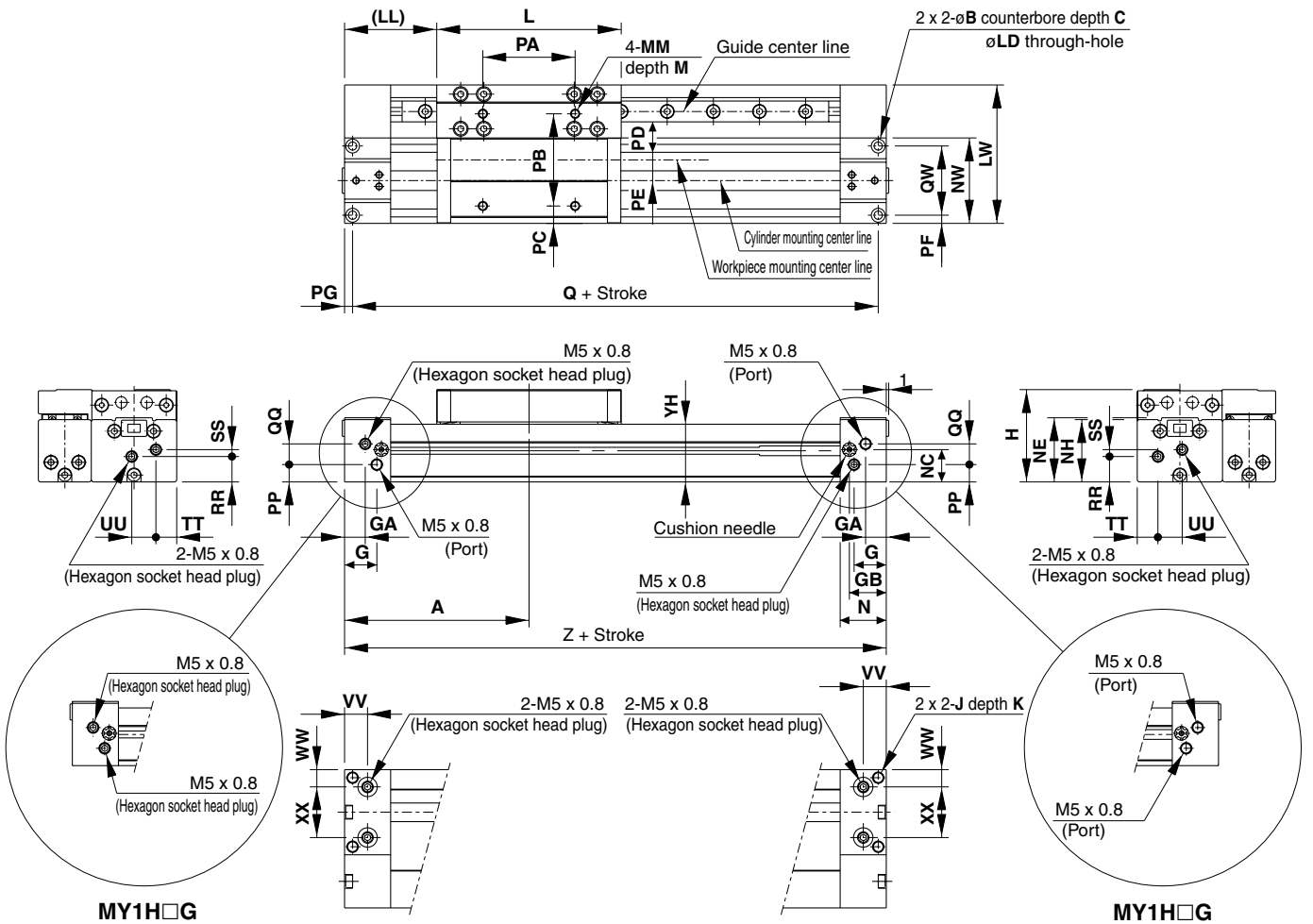

(mm)

Model	A	B	C	G	GA	GB	H	J	K	L	LD	LL	LW	M	MM	N	NC	NE	NH	NW
MY1H16□	80	6	3.5	14	9	16	40	M5 x 0.8	10	80	3.5	40	60	7	M4 x 0.7	20	14	27.8	27	37
MY1H20□	100	7.5	4.5	12.5	12.5	17.5	46	M6 x 1	12	100	4.5	50	78	8	M5 x 0.8	25	17.5	34	33.5	45

(mm)

Model	PA	PB	PC	PD	PE	PF	PG	PP	Q	QQ	QW	RR	SS	TT	UU	VV	WW	XX	YH	Z
MY1H16□	40	40	7.5	21	9	3.5	3.5	7.5	153	9	30	11	3	9	10.5	10	7.5	22	25	160
MY1H20□	50	40	14.5	27	12	4.5	4.5	11.5	191	11	36	14.5	5	10.5	12	12.5	10.5	24	31.5	200

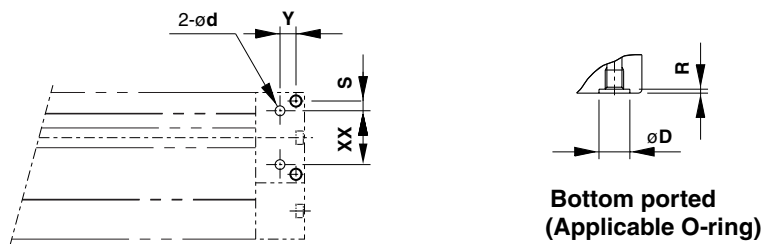

Hole Size for Centralized Piping on the Bottom

Model	WX	Y	S	d	D	R	Applicable O-ring
MY1H16□	22	6.5	4	4	8.4	1.1	C6
MY1H20□	24	8	6	4	8.4	1.1	

(Machine the mounting side to the dimensions below.)

Mechanically Jointed Rodless Cylinder High Precision Guide Type Series MY1H

Standard Type/Centralized Piping Type $\phi 25$, $\phi 32$, $\phi 40$ Refer to page 8-11-9 regarding centralized piping port variations.

MY1H25L□/32L□/40L□ — Stroke

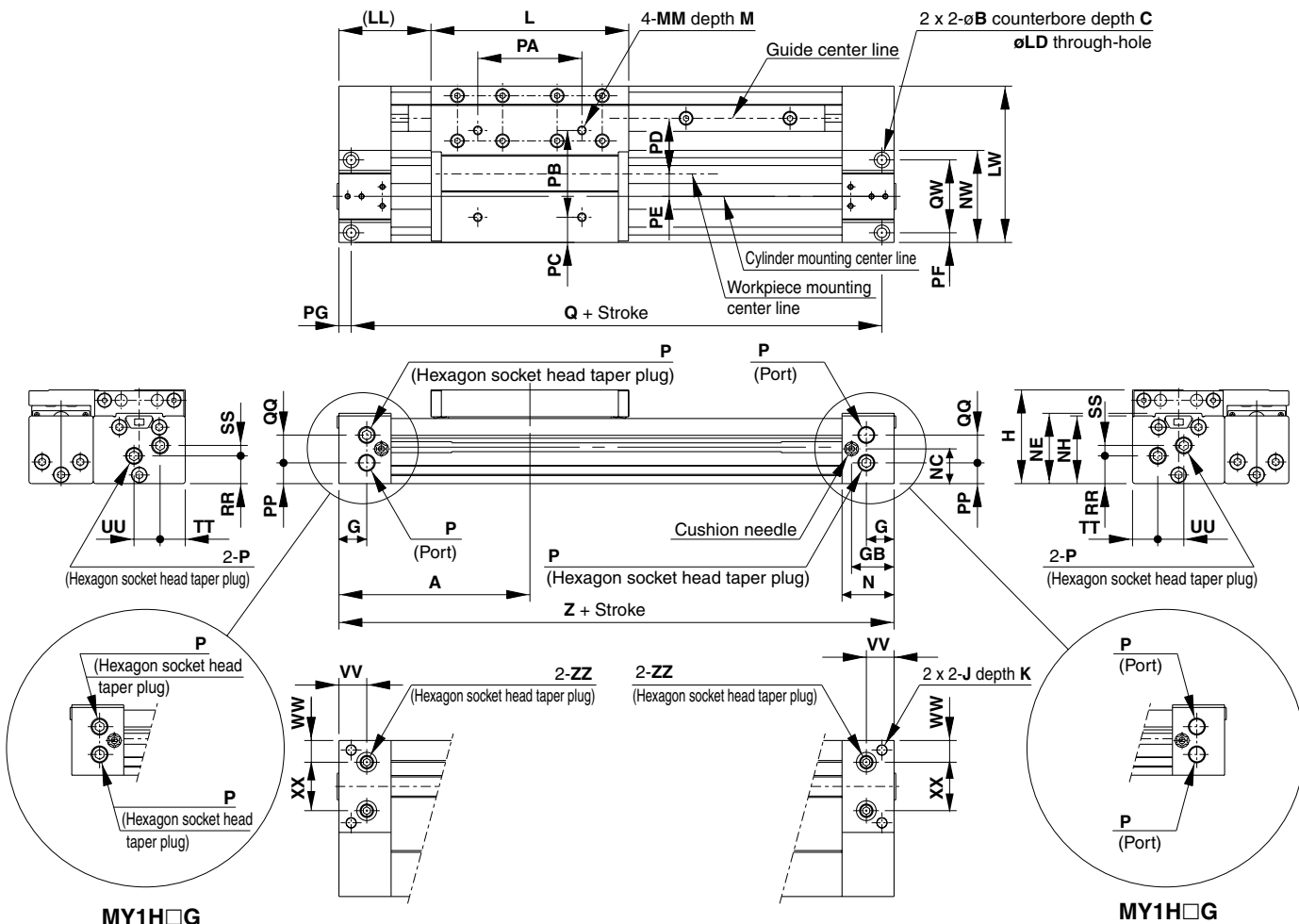

- MX□
- MTS
- MY□
- CY□
- MG□
- CX□
- D-
- X
- 20-
- Data

Model	A	B	C	G	GB	H	J	K	L	LD	LL	LW	M	MM	N	NC	NE	NH	NW	P
MY1H25□	110	9	5.5	16	24.5	54	M6 x 1	9.5	114	5.6	53	90	9	M5 x 0.8	30	20	40.5	39	53	Rc 1/8
MY1H32□	140	11	6.6	19	30	68	M8 x 1.25	16	140	6.8	70	110	13	M6 x 1	37	25	50	49	64	Rc 1/8
MY1H40□	170	14	8.5	23	36.5	84	M10 x 1.5	15	170	8.6	85	121	13	M6 x 1	45	30.5	63	61.5	75	Rc 1/4

"P" indicates cylinder supply ports.

Model	PA	PB	PC	PD	PE	PF	PG	PP	Q	QQ	QW	RR	SS	TT	UU	VV	WW	XX	YH	Z	ZZ
MY1H25□	60	50	14.5	32	13	5.5	7	12	206	16	42	16	6	14.5	15	16	12.5	28	37.5	220	Rc 1/16
MY1H32□	80	60	15	42	13	6.5	8	17	264	11	51	16	4	16	16	19	16	32	47	280	Rc 1/16
MY1H40□	100	80	20.5	37.5	23	8	9	18.5	322	11	59	24	10.5	20	22	23	19.5	36	59.5	340	Rc 1/8

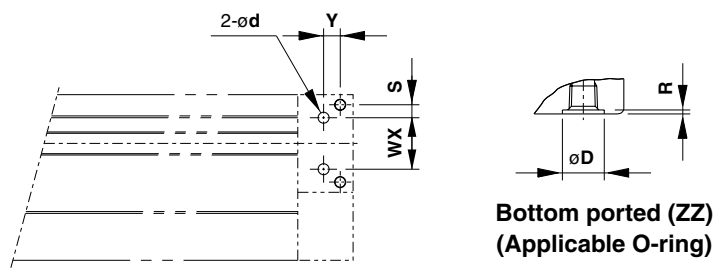

Hole Size for Centralized Piping on the Bottom

Model	WX	Y	S	d	D	R	Applicable O-ring
MY1H25□	28	9	7	6	11.4	1.1	C9
MY1H32□	32	11	9.5	6	11.4	1.1	
MY1H40□	36	14	11.5	8	13.4	1.1	C11.2

(Machine the mounting side to the dimensions below.)



Series MY1H

Stroke Adjusting Unit

With adjusting bolt

MY1H Bore size Stroke A

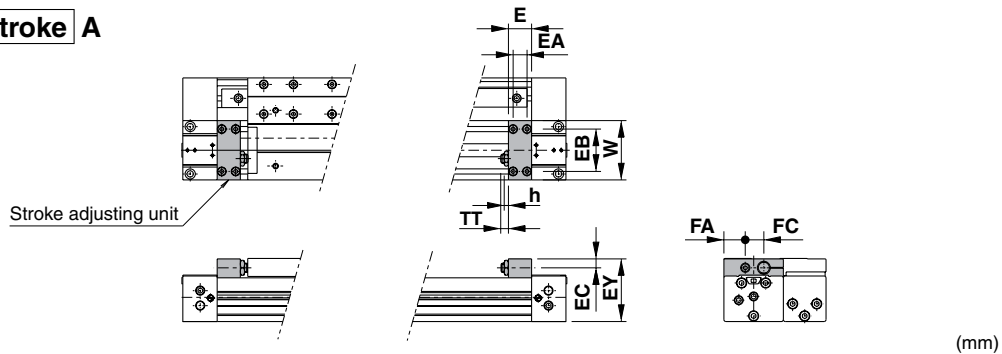

Applicable bore size	E	EA	EB	EC	EY	FA	FC	h	TT	W
MY1H16	14.6	7	28	5.8	39.5	11.5	13	3.6	5.4 (Max. 11)	37
MY1H20	19	10	33	5.8	45.5	15	14	3.6	6 (Max. 12)	45
MY1H25	18	9	40	7.5	53.5	20	17	3.5	5 (Max. 16.5)	53
MY1H32	25	14	45.6	9.5	67.5	23	20	4.5	8 (Max. 20)	64
MY1H40	31	19	55	11	82	24.5	26	4.5	9 (Max. 25)	75

With low load shock absorber
+ Adjusting bolt

MY1H Bore size Stroke A

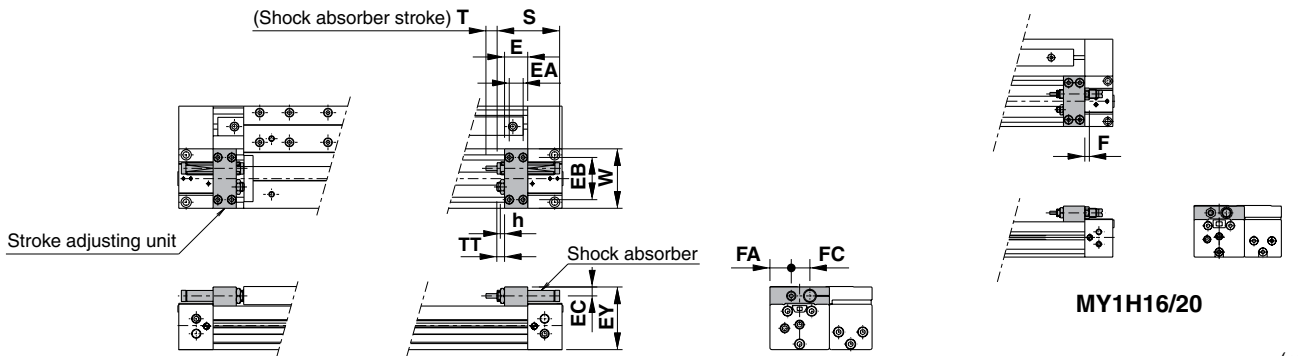

Applicable bore size	E	EA	EB	EC	EY	F	FA	FC	h	S	T	TT	W	Shock absorber model
MY1H16	14.6	7	28	5.8	39.5	4	11.5	13	3.6	40.8	6	5.4 (Max. 11)	37	RB0806
MY1H20	19	10	33	5.8	45.5	4	15	14	3.6	40.8	6	6 (Max. 12)	45	RB0806
MY1H25	18	9	40	7.5	53.5	—	20	17	3.5	46.7	7	5 (Max. 16.5)	53	RB1007
MY1H32	25	14	45.6	9.5	67.5	—	23	20	4.5	67.3	12	8 (Max. 20)	64	RB1412
MY1H40	31	19	55	11	82	—	24.5	26	4.5	67.3	12	9 (Max. 25)	75	RB1412

With high load shock absorber
+ Adjusting bolt

MY1H Bore size Stroke A

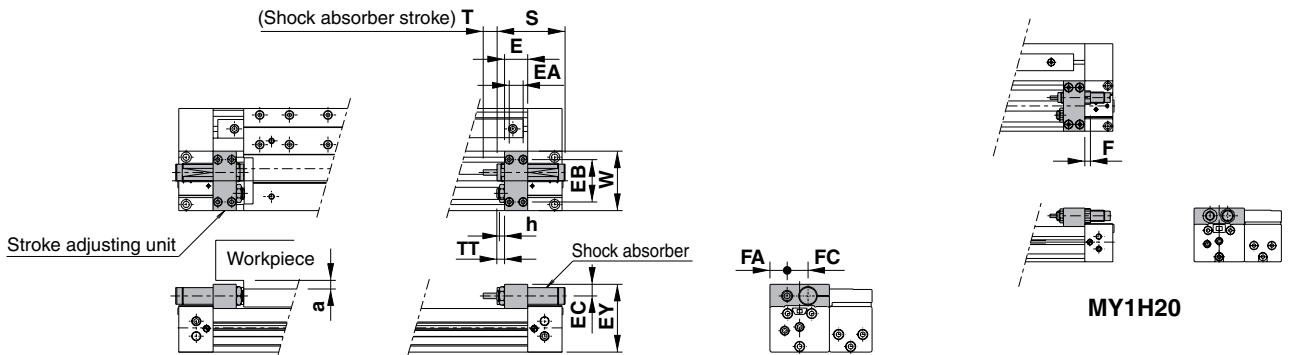

* Since dimension EY of the H type unit is greater than the table top height (dimension H), when mounting a workpiece that exceeds the overall length (dimension L) of the slide table, allow a clearance of dimension "a" or larger on the workpiece side.

Applicable bore size	E	EA	EB	EC	EY	F	FA	FC	h	S	T	TT	W	Shock absorber model	a
MY1H20	19	10	33	7.7	49.5	5	14.3	15.7	3.5	46.7	7	6 (Max. 12)	45	RB1007	4
MY1H25	18	9	40	9	57	—	18	17.5	4.5	67.3	12	5 (Max. 16.5)	53	RB1412	3.5
MY1H32	25	14	45.6	12.4	73	—	18.5	22.5	5.5	73.2	15	8 (Max. 20)	64	RB2015	5.5
MY1H40	31	19	55	12.4	86	—	26.5	22	5.5	73.2	15	9 (Max. 25)	75	RB2015	2.5

Mechanically Jointed Rodless Cylinder High Precision Guide Type Series MY1H

With End Lock $\varnothing 16$ to $\varnothing 40$

Dimensions for types other than end lock are identical to the standard type dimensions. For details about dimensions, etc., refer to page 8-11-80 to 81.

MY1H□-□E (Right end)

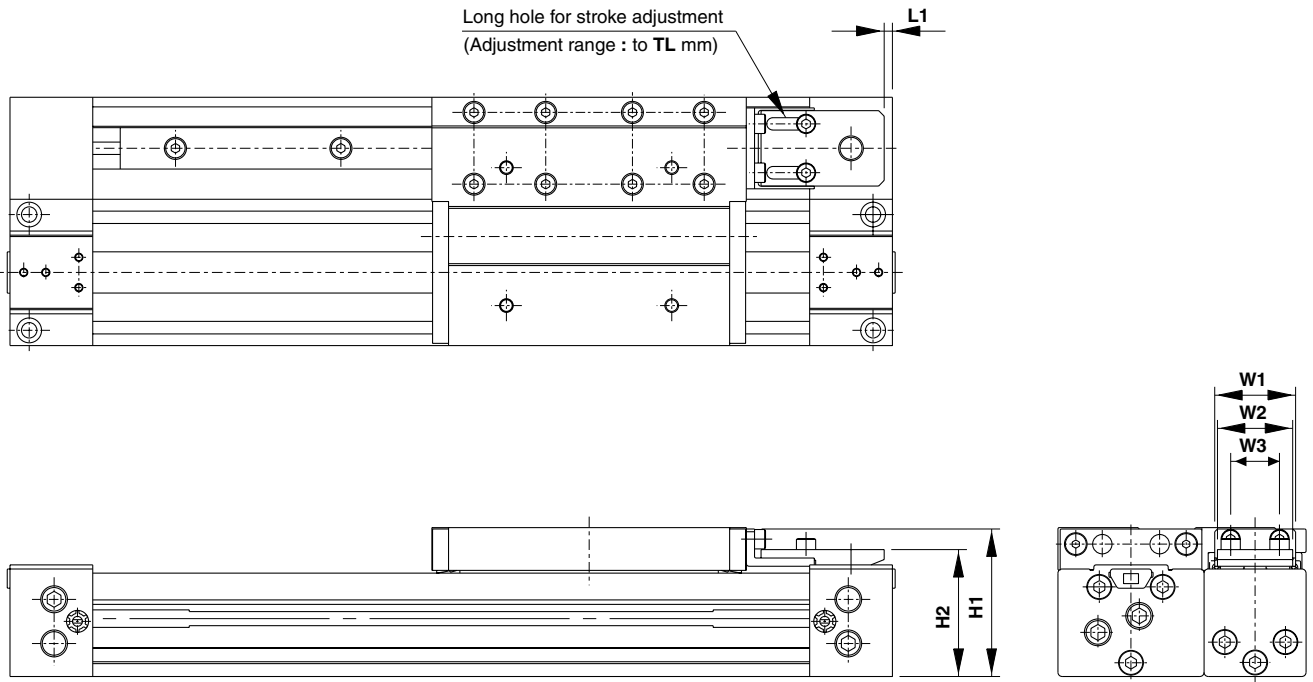

- MX□
- MTS
- MY□**
- CY□
- MG□
- CX□
- D-
- X
- 20-
- Data

MY1H□-□F (Left end)

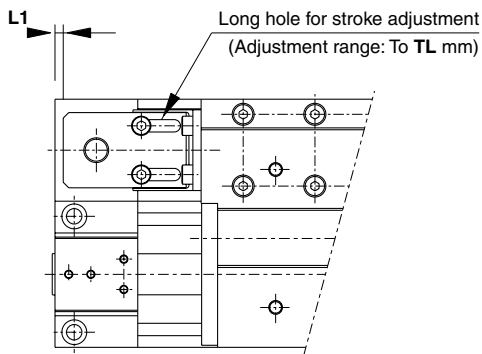

MY1H□-□W (Both ends)

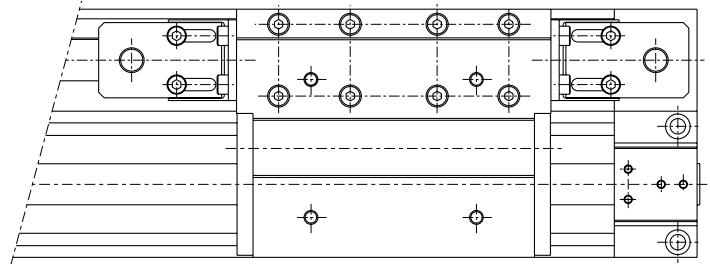

(mm)

Model	H1	H2	L1	TL	W1	W2	W3
MY1H16□	39.2	33	0.5	5.6	18	16	10.4
MY1H20□	45.7	39.5	3	6	18	16	10.4
MY1H25□	53.5	46	3	11.5	29.3	27.3	17.7
MY1H32□	67	56	6.5	12	29.3	27.3	17.7
MY1H40□	83	68.5	10.5	16	38	35	24.4

Series MY1H

Side Support

Side support A MY-S□A

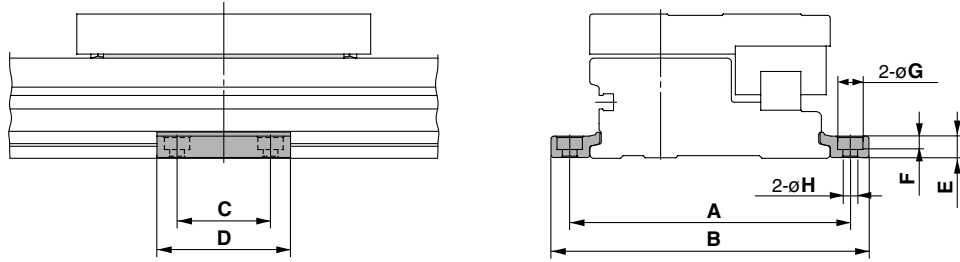

Side support B MY-S□B

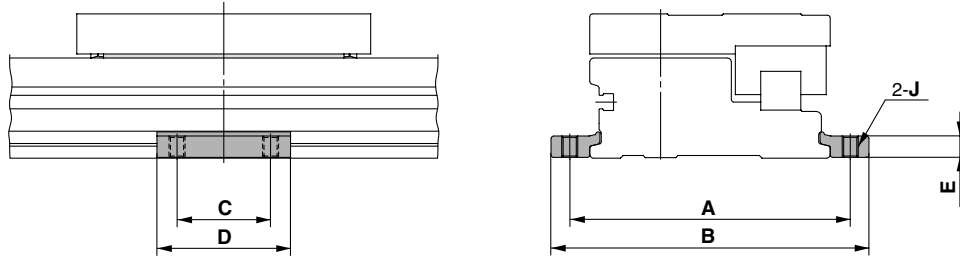

(mm)

Model	Applicable bore size	A	B	C	D	E	F	G	H	J
MY-S10 ^A _B	MY1H10	53	61.6	12	21	3.6	1.8	6.5	3.4	M4 x 0.7
MY-S16 ^A _B	MY1H16	71	81.6	15	26	4.9	3	6.5	3.4	M4 x 0.7
MY-S20 ^A _B	MY1H20	91	103.6	25	38	6.4	4	8	4.5	M5 x 0.8
MY-S25 ^A _B	MY1H25	105	119	35	50	8	5	9.5	5.5	M6 x 1
MY-S32 ^A _B	MY1H32	130	148	45	64	11.7	6	11	6.6	M8 x 1.25
MY-S40 ^A _B	MY1H40	145	167	55	80	14.8	8.5	14	9	M10 x 1.5

Guide for Side Support Application

For long stroke operation, the cylinder tube may be deflected depending on its own weight and the load weight. In such a case, use a side support in the middle section. The spacing (l) of the support must be no more than the values shown in the graph on the right.

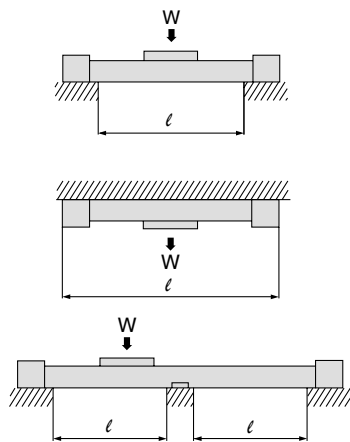

⚠ Caution

1. If the cylinder mounting surfaces are not measured accurately, using a side support may cause poor operation. Therefore, be sure to level the cylinder tube when mounting. Also, for long stroke operation involving vibration and impact, use of a side support is recommended even if the spacing value is within the allowable limits shown in the graph.
2. Support brackets are not for mounting; use them solely for providing support.

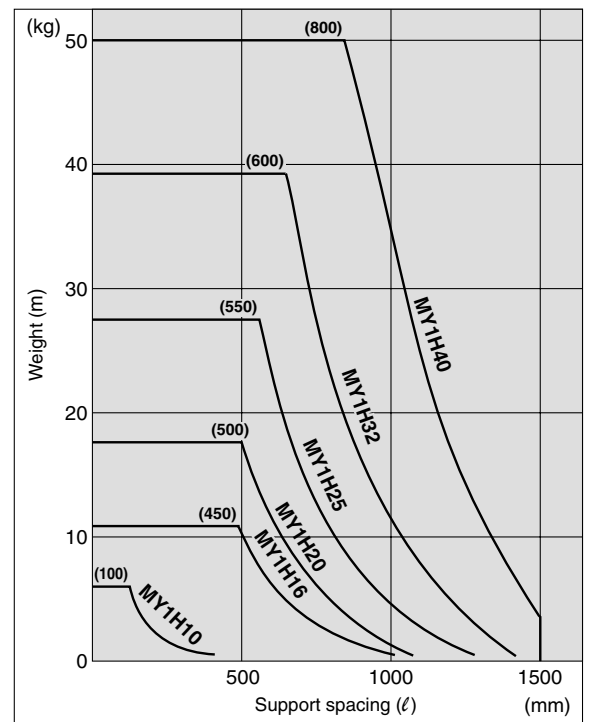

Mechanically Jointed Rodless Cylinder High Precision Guide Type Series MY1H

Construction: $\phi 10$

Centralized piping type

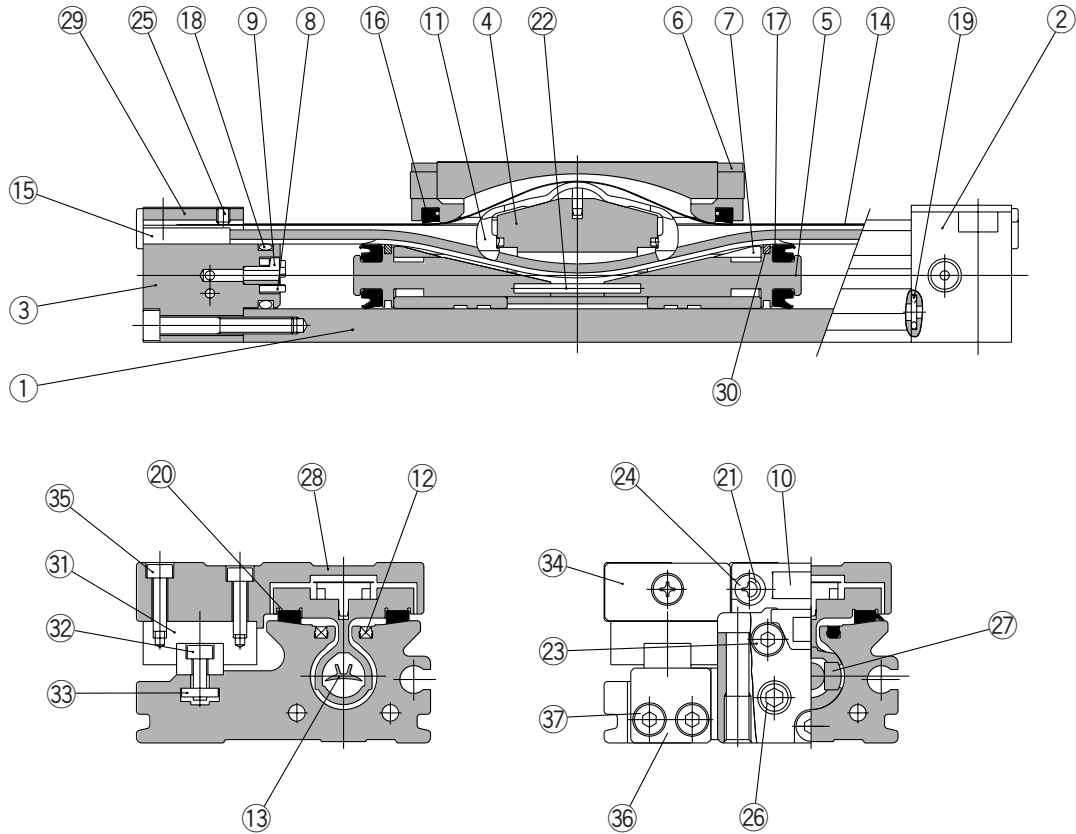

MX

MTS

MY

CY

MG

CX

D-

-X

20-

Data

Component Parts

No.	Description	Material	Note
①	Cylinder tube	Aluminum alloy	Hard anodized
②	Head cover WR	Aluminum alloy	Painted
③	Head cover WL	Aluminum alloy	Painted
④	Piston yoke	Aluminum alloy	Hard anodized
⑤	Piston	Aluminum alloy	Chromated
⑥	End cover	Special resin	
⑦	Wear ring	Special resin	
⑧	Bumper	Polyurethane rubber	
⑨	Holder	Stainless steel	
⑩	Stopper	Carbon steel	Nickel plated
⑪	Belt separator	Special resin	
⑫	Seal magnet	Rubber magnet	
⑮	Belt clamp	Special resin	
⑳	Bearing	Special resin	
㉑	Spacer	Chromium molybdenum steel	Nickel plated

No.	Description	Material	Note
㉒	Spring pin	Stainless steel	
㉓	Hexagon socket head cap screw	Chromium molybdenum steel	Nickel plated
㉔	Round head Phillips screw	Carbon steel	Nickel plated
㉕	Hexagon socket head set screw	Carbon steel	Black zinc chromated
㉖	Hexagon socket head plug	Carbon steel	Nickel plated
㉗	Magnet	Rare earth magnet	
㉘	Slide table	Aluminum alloy	Hard anodized
㉙	Head plate	Stainless steel	
㉚	Felt	Felt	
㉛	Linear guide	—	
㉜	Hexagon socket head cap screw	Chromium molybdenum steel	Nickel plated
㉝	Square nut	Carbon steel	Nickel plated
㉞	Stopper plate	Carbon steel	Nickel plated
㉟	Hexagon socket head cap screw	Chromium molybdenum steel	Nickel plated
㊱	Guide stopper	Carbon steel	Nickel plated
㊲	Hexagon socket head cap screw	Chromium molybdenum steel	Nickel plated

Seal List

No.	Description	Material	Qty.	MY1H10
⑬	Seal belt	Special resin	1	MY10-16A-Stroke
⑭	Dust seal band	Stainless steel	1	MY10-16B-Stroke
⑰	Scraper	NBR	2	MYB10-15AR0597
⑱	Piston seal	NBR	2	GM10
⑲	Tube gasket	NBR	2	P7
⑲	O-ring	NBR	4	$\phi 5.33 \times \phi 3.05 \times \phi 1.14$

Series MY1H

Construction: $\varnothing 16$ to $\varnothing 40$

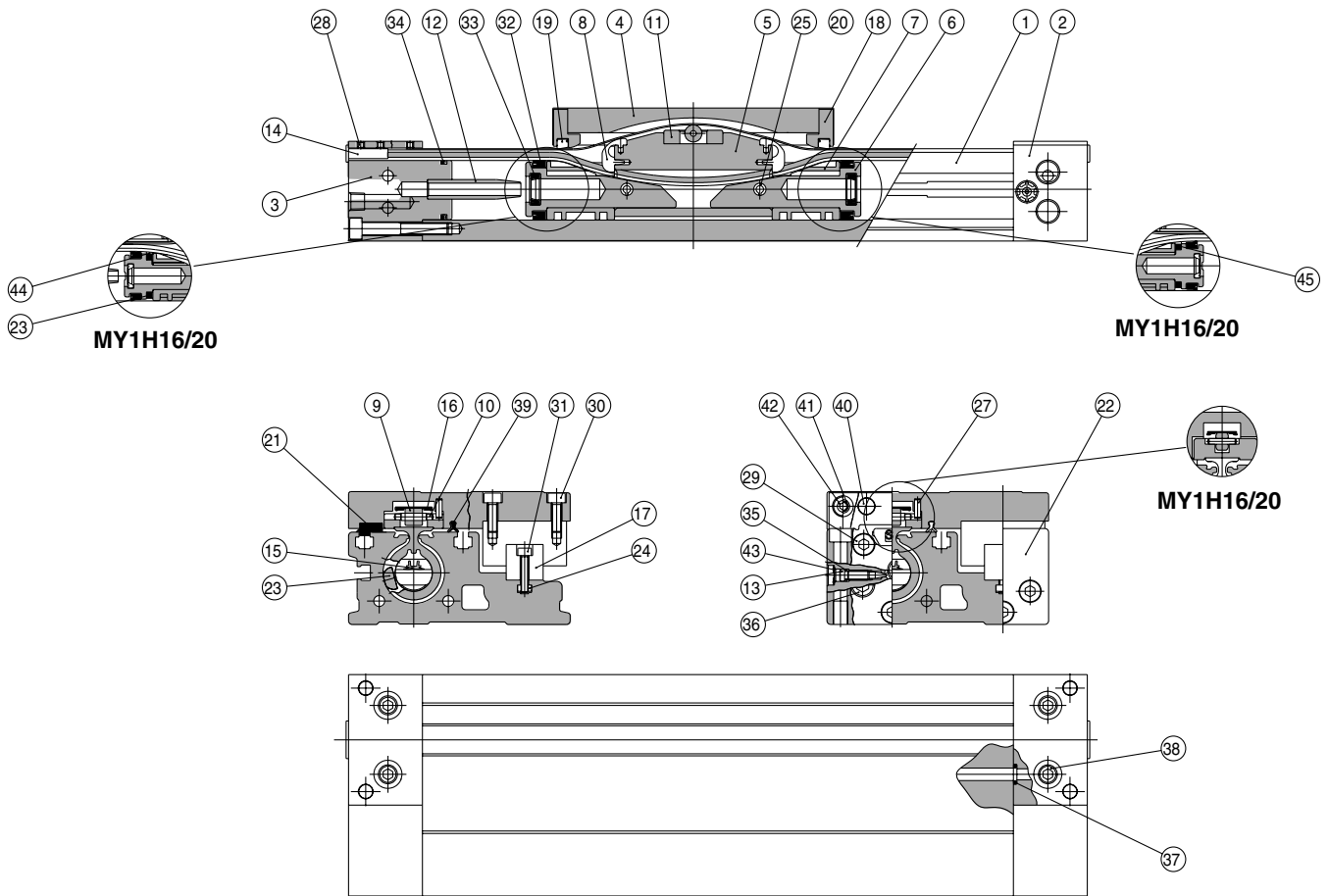

Component Parts

No.	Description	Material	Note
①	Cylinder tube	Aluminum alloy	Hard anodized
②	Head cover WR	Aluminum alloy	Painted
③	Head cover WL	Aluminum alloy	Painted
④	Slide table	Aluminum alloy	Hard anodized
⑤	Piston yoke	Aluminum alloy	Chromated
⑥	Piston	Aluminum alloy	Chromated
⑦	Wear ring	Special resin	
⑧	Belt separator	Special resin	
⑨	Guide roller	Special resin	
⑩	Guide roller shaft	Stainless steel	
⑪	Coupler	Sintered iron material	
⑫	Cushion ring	Brass	
⑬	Cushion needle	Rolled steel	Nickel plated
⑭	Belt clamp	Special resin	
⑰	Guide		
⑱	End cover	Special resin	
㉑	Bearing	Special resin	
㉒	Guide cover	Aluminum alloy	Coated

No.	Description	Material	Note
㉓	Magnet	Rare earth magnet	
㉔	Square nut	Carbon steel	Nickel plated
㉕	Spring pin	Carbon tool steel	Black zinc chromated
㉗	Parallel pin	Stainless steel	($\varnothing 16$, $\varnothing 20$)
㉘	Hexagon socket head set screw	Chromium molybdenum steel	Black zinc chromated/Nickel plated
㉙	Hexagon socket head cap screw	Chromium molybdenum steel	Nickel plated
㉚	Hexagon socket head cap screw	Chromium molybdenum steel	Nickel plated
㉛	Hexagon socket head cap screw	Chromium molybdenum steel	Nickel plated
㉞	Hexagon socket head taper plug	Carbon steel	Nickel plated
㉟	Hexagon socket head taper plug	Carbon steel	Nickel plated
㊱	Stopper	Carbon steel	Nickel plated
㊲	Spacer	Stainless steel	
㊳	Hexagon socket button head screw	Chromium molybdenum steel	Nickel plated
㊴	Type CR retaining ring	Spring steel	
㊵	Felt A	Felt	($\varnothing 16$, $\varnothing 20$)
㊶	Felt B	Felt	($\varnothing 16$, $\varnothing 20$)

Seal List

No.	Description	Material	Qty.	MY1M16	MY1M20	MY1M25	MY1M32	MY1M40
15	Seal belt	Special resin	1	MY16-16A-Stroke	MY20-16A-Stroke	MY25-16A-Stroke	MY32-16A-Stroke	MY40-16A-Stroke
16	Dust seal band	Stainless steel	1	MY16-16B-Stroke	MY20-16B-Stroke	MY25-16B-Stroke	MY32-16B-Stroke	MY40-16B-Stroke
19	Scraper	NBR	2	MYM16-15AK2900A	MYM16-15AK2900A	MYM25-15AK2902	MYM25-15AK2902	MYM25-15AK2902
32	Piston seal	NBR	2	GMY16	GMY20	GMY25	GMY32	GMY40
33	Cushion seal	NBR	2	MYB16-15-A7163	MYB20-15-A7164	RCS-8	RCS-10	RCS-12
34	Tube gasket	NBR	2	P12	P16	TMY-25	TMY-32	TMY-40
35	O-ring	NBR	2	$\varnothing 4 \times \varnothing 1.8 \times \varnothing 1.1$	$\varnothing 5.1 \times \varnothing 3 \times \varnothing 1.05$	$\varnothing 5.1 \times \varnothing 3 \times \varnothing 1.05$	$\varnothing 7.15 \times \varnothing 3.75 \times \varnothing 1.7$	$\varnothing 7.15 \times \varnothing 3.75 \times \varnothing 1.7$
37	O-ring	NBR	4	$\varnothing 6.2 \times \varnothing 3 \times \varnothing 1.6$	$\varnothing 7 \times \varnothing 4 \times \varnothing 1.5$	P-5	P-6	C-9
39	Side scraper	Special resin	1	MYH16-15BK2900B	MYH20-15BK2901B	MYH25-15BK2902B	MYH32-15BK2903B	MYH40-15BK2904B

Note) Two types of dust seal bands are available. Verify the type to use, since the part number varies depending on the treatment of the hexagon socket head set screw ㉘. (A) Black zinc chromated → MY□□-16B-Stroke (B) Nickel plated → MY□□-16BW-Stroke

Mechanically Jointed Rodless Cylinder High Precision Guide Type Series MY1H

Construction: $\phi 16, \phi 40$

With End Lock

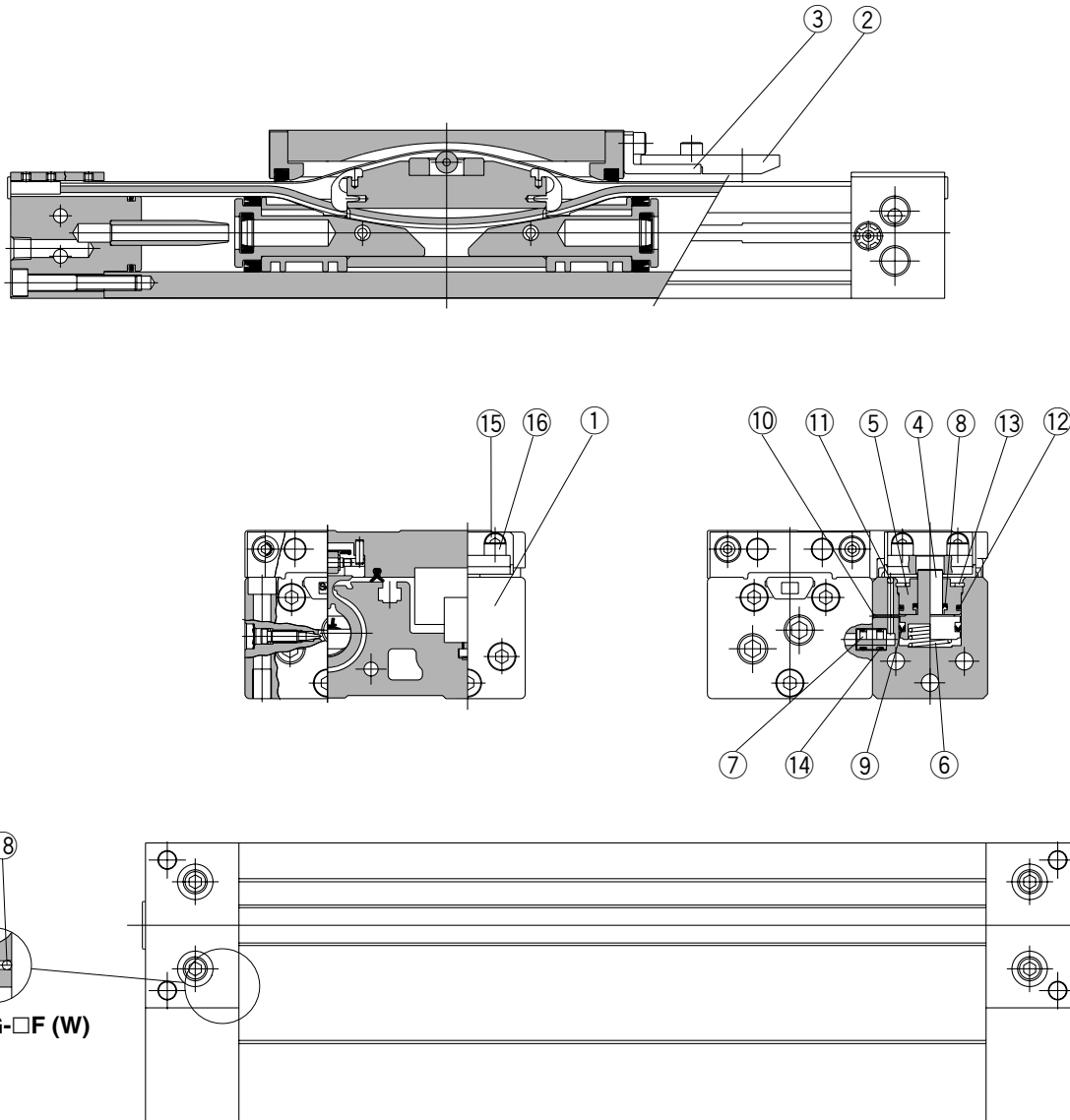

- MX
- MTS
- MY**
- CY
- MG
- CX
- D-
- X
- 20-
- Data

Component Parts

No.	Description	Material	Note
①	Locking body	Aluminum alloy	Painted
②	Lock finger	Carbon steel	After quenching, nickel plated
③	Lock finger bracket	Rolled steel	Nickel plated
④	Lock piston	Carbon tool steel	After quenching, electroless nickel plated
⑤	Rod cover	Aluminum alloy	Hard anodized
⑥	Return spring	Spring steel	Zinc chromated
⑦	Bypass pipe	Aluminum alloy	Hard anodized
⑩	Steel ball	High carbon chrome bearing steel	
⑪	Steel ball	High carbon chrome bearing steel	
⑬	Round type R snap ring	Carbon tool steel	Nickel plated
⑮	Hexagon socket head cap screw	Chromium molybdenum steel	Nickel plated
⑯	Hexagon socket head cap screw	Chromium molybdenum steel	Nickel plated
⑰	Steel ball	High carbon chrome bearing steel	
⑱	Steel ball	High carbon chrome bearing steel	

Seal List

No.	Description	Material	Qty.	MY1H16	MY1H20	MY1H25	MY1H32	MY1H40
⑧	Rod seal	NBR	1	DYR-4	DYR-4	DYR8K	DYR8K	DYR8K
⑨	Piston seal	NBR	1	DYP-12	DYP-12	DYP-20	DYP-20	DYP-20
⑫	O-ring	NBR	1	C-9	C-9	C-18	C-18	C-18
⑭	O-ring	NBR	2	$\phi 5.5 \times \phi 3.5 \times \phi 1.0$	$\phi 5.5 \times \phi 3.5 \times \phi 1.0$	C-5	C-5	C-5

Series MY1HT

High Rigidity/High Precision Guide Type

ø50, ø63

MX□

MTS

MY□

CY□

MG□

CX□

D-

-X

20-

Data



The use of two linear guides allows a maximum load of 320 kg. (ø63)

Rodless cylinder
MY1BH

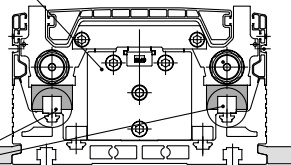

2 linear guides

Easy maintenance is stressed by a revolutionary construction which allows cylinder replacement without disturbing the guide units or workpiece.

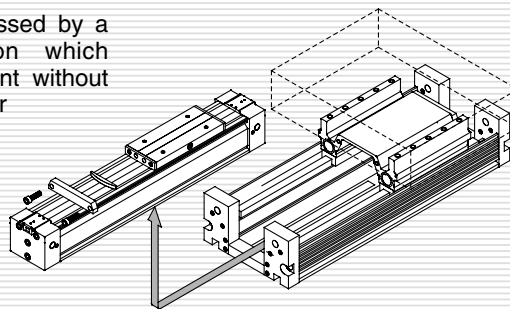

Series MY1HT

Before Operation

Maximum Allowable Moment/Maximum Load Weight

Model	Bore size (mm)	Maximum allowable moment (N·m)			Maximum load weight (kg)		
		M ₁	M ₂	M ₃	m ₁	m ₂	m ₃
MY1HT	50	140	180	140	200	140	200
	63	240	300	240	320	220	320

The above values are the maximum allowable values for moment and load. Refer to each graph regarding the maximum allowable moment and maximum allowable load for a particular piston speed.

Load weight (kg)

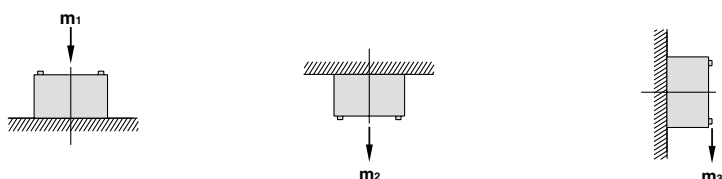

Moment (N·m)

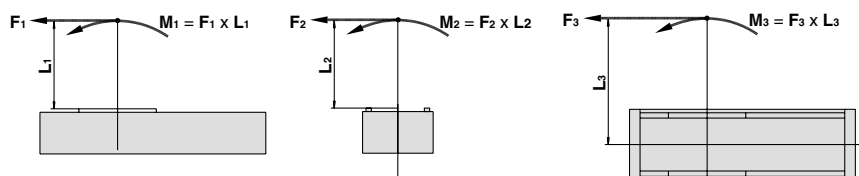

<Calculation of guide load factor>

1. Maximum allowable load (1), static moment (2), and dynamic moment (3) (at the time of impact with stopper) must be examined for the selection calculations.

* To evaluate, use \bar{v}_a (average speed) for (1) and (2), and v (collision speed $v = 1.4\bar{v}_a$) for (3). Calculate m_{max} for (1) from the maximum allowable load graph (m_1, m_2, m_3) and M_{max} for (2) and (3) from the maximum allowable moment graph (M_1, M_2, M_3).

$$\text{Sum of guide load factors } \Sigma \alpha = \frac{\text{Load weight [m]}}{\text{Maximum allowable load [m}_{max}\text{]}} + \frac{\text{Static moment [M]}^{(1)}}{\text{Allowable static moment [M}_{max}\text{]}} + \frac{\text{Dynamic moment [M}_E\text{]}^{(2)}}{\text{Allowable dynamic moment [M}_{Emax}\text{]}} \leq 1$$

Note 1) Moment caused by the load, etc., with cylinder in resting condition.

Note 2) Moment caused by the impact load equivalent at the stroke end (at the time of impact with stopper).

Note 3) Depending on the shape of the workpiece, multiple moments may occur. When this happens, the sum of the load factors ($\Sigma \alpha$) is the total of all such moments.

2. Reference formula [Dynamic moment at impact]

Use the following formulae to calculate dynamic moment when taking stopper impact into consideration.

m: Load weight (kg)

F: Load (N)

F_E: Load equivalent to impact (at impact with stopper) (N)

\bar{v}_a : Average speed (mm/s)

M: Static moment (N·m)

$$v = 1.4\bar{v}_a \text{ (mm/s)} \quad F_E = 1.4\bar{v}_a \cdot \delta \cdot m \cdot g$$

$$\therefore M_E = \frac{1}{3} \cdot F_E \cdot L_1 = 4.57\bar{v}_a \delta m L_1 \text{ (N·m)}$$

v : Collision speed (mm/s)

L₁: Distance to the load's center of gravity (m)

M_E: Dynamic moment (N·m)

δ : Damper coefficient

With rubber bumper = 4/100

(MY1B10, MY1H10)

With air cushion = 1/100

With shock absorber = 1/100

g: Gravitational acceleration (9.8 m/s²)

Note 4) $1.4\bar{v}_a \delta$ is a dimensionless coefficient for calculating impact force.

Note 5) Average load coefficient ($= \frac{1}{3}$): This coefficient is for averaging the maximum load moment at the time of stopper impact according to service life calculations.

3. For detailed selection procedures, refer to pages 8-11-92 and 8-11-93.

Maximum Allowable Moment

Select the moment from within the range of operating limits shown in the graphs. Note that the maximum allowable load value may sometimes be exceeded even within the operating limits shown in the graphs. Therefore, also check the allowable load for the selected conditions.

Maximum Load Weight

Select the load from within the range of limits shown in the graphs. Note that the maximum allowable moment value may sometimes be exceeded even within the operating limits shown in the graphs. Therefore, also check the allowable moment for the selected conditions.

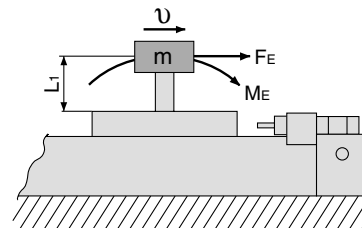

Mechanically Jointed Rodless Cylinder High Rigidity/High Precision Guide Type **Series MY1HT**

MY1HT/M₁

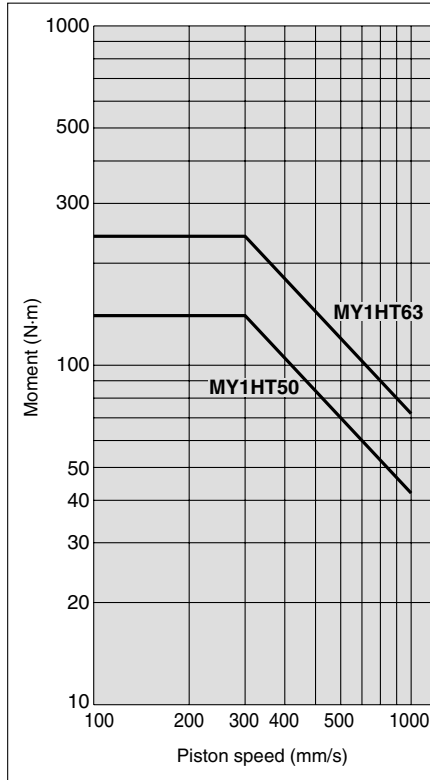

MY1HT/M₂

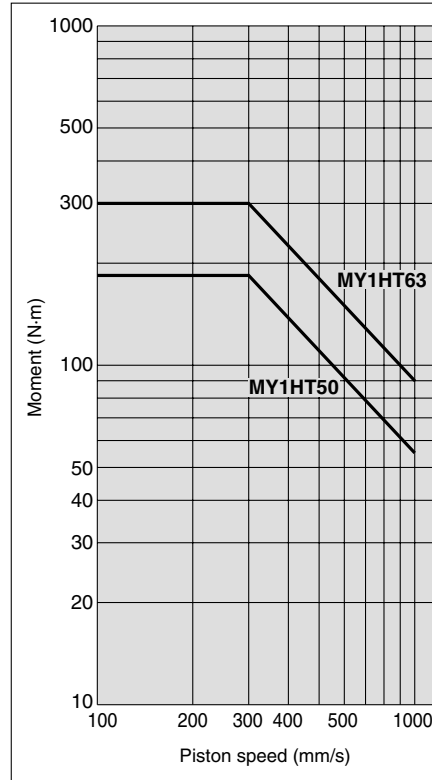

MY1HT/M₃

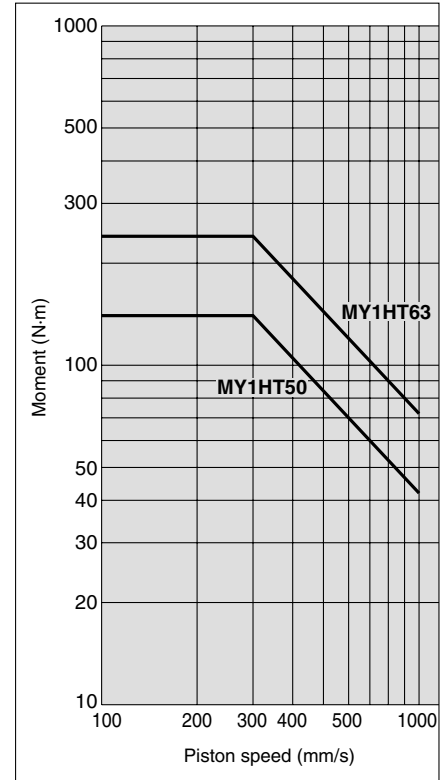

MX

MTS

MY

CY

MG

CX

D-

-X

20-

Data

MY1HT/m₁

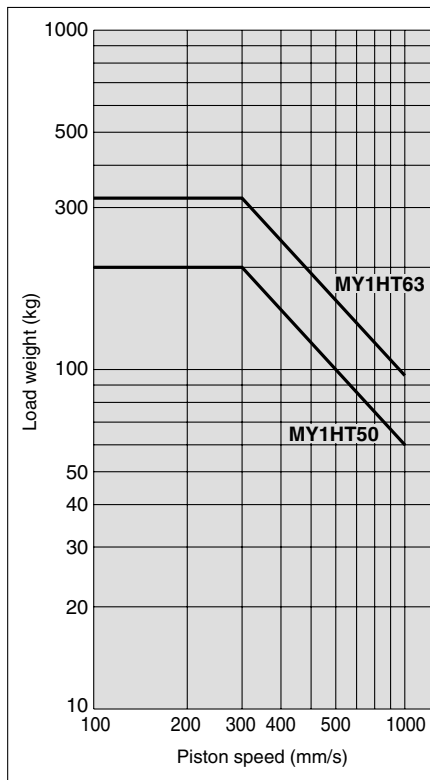

MY1HT/m₂

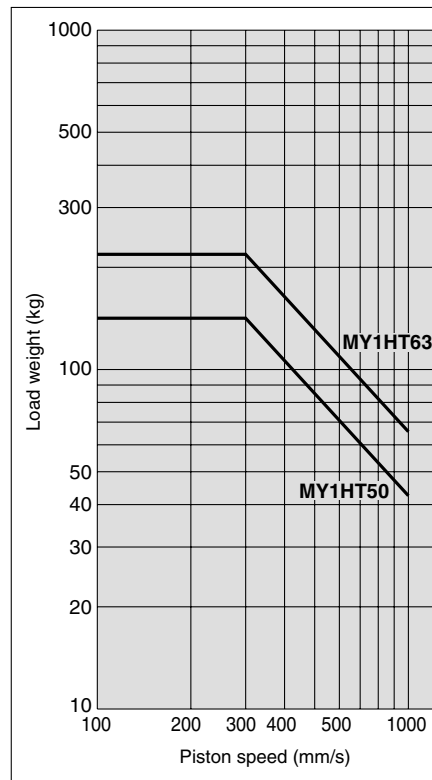

MY1HT/m₃

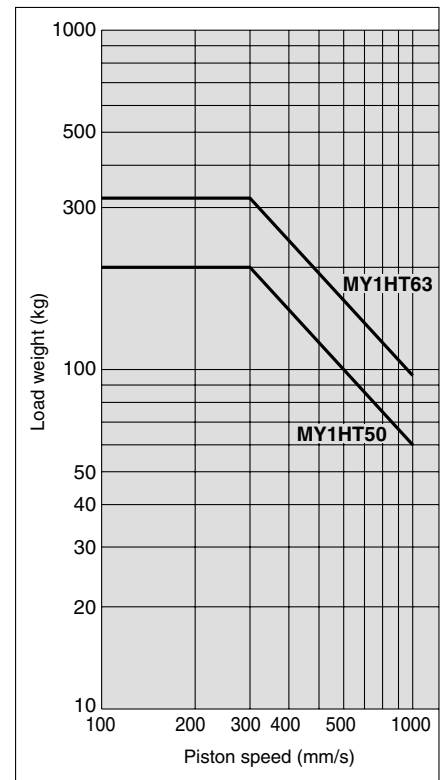

Series MY1HT Model Selection

Following are the steps for selecting the most suitable Series MY1 to your application.

Calculation of Guide Load Factor

1. Operating Conditions

Cylinder MY1HT50-600
Average operating speed v_a ... 700 mm/s
Mounting orientation Vertical mounting
Cushion Shock absorber
($\delta = 1/100$)

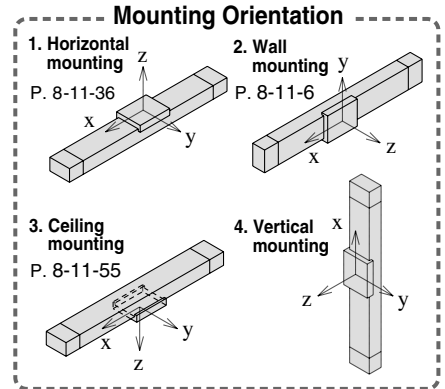
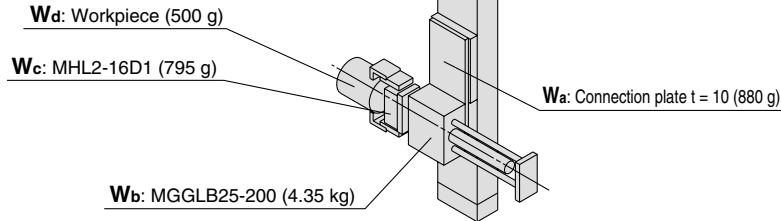

For actual examples of calculation for each orientation, refer to the pages above.

2. Load Blocking

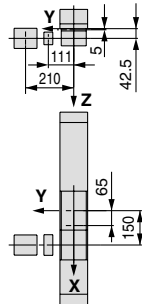

Weight and Center of Gravity for Each Workpiece

Workpiece no. W_n	Weight m_n	Center of gravity		
		X-axis X_n	Y-axis Y_n	Z-axis Z_n
W_a	0.88 kg	65 mm	0 mm	5 mm
W_b	4.35 kg	150 mm	0 mm	42.5 mm
W_c	0.795 kg	150 mm	111 mm	42.5 mm
W_d	0.5 kg	150 mm	210 mm	42.5 mm

$n = a, b, c, d$

3. Composite Center of Gravity Calculation

$$m_4 = \sum m_n = 0.88 + 4.35 + 0.795 + 0.5 = \mathbf{6.525 \text{ kg}}$$

$$X = \frac{1}{m_4} \times \sum (m_n \times X_n) = \frac{1}{6.525} (0.88 \times 65 + 4.35 \times 150 + 0.795 \times 150 + 0.5 \times 150) = \mathbf{138.5 \text{ mm}}$$

$$Y = \frac{1}{m_4} \times \sum (m_n \times Y_n) = \frac{1}{6.525} (0.88 \times 0 + 4.35 \times 0 + 0.795 \times 111 + 0.5 \times 210) = \mathbf{29.6 \text{ mm}}$$

$$Z = \frac{1}{m_4} \times \sum (m_n \times Z_n) = \frac{1}{6.525} (0.88 \times 5 + 4.35 \times 42.5 + 0.795 \times 42.5 + 0.5 \times 42.5) = \mathbf{37.4 \text{ mm}}$$

4. Calculation of Load Factor for Static Load

m_4 : Weight

m_4 is the mass which can be transferred by the thrust, and as a rule, is actually about 0.3 to 0.7 of the thrust. (This differs depending on the operating speed.)

M_1 : Moment

$M_1 \text{ max}$ (from (1) of graph MY1HT/ M_1) = 60 (N·m)

$$M_1 = m_4 \times g \times Z = 6.525 \times 9.8 \times 37.4 \times 10^{-3} = 2.39 \text{ (N·m)}$$

$$\text{Load factor } \alpha_1 = M_1 / M_{1\text{max}} = 2.39 / 60 = \mathbf{0.04}$$

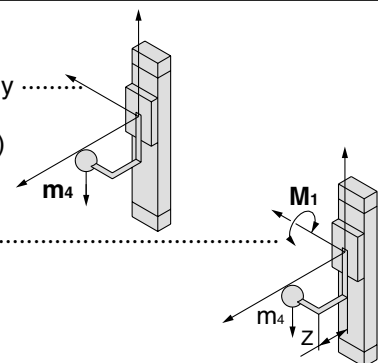

M₃ : Moment

M_{3max} (from (2) of graph MY1HT/M₃) = 60 (N·m)

M₃ = m₄ x g x Y = 6.525 x 9.8 x 29.6 x 10⁻³ = 1.89 (N·m)

Load factor α₂ = M₃/M_{3max} = 1.89/60 = **0.03**

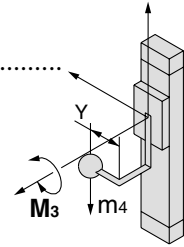

5. Calculation of Load Factor for Dynamic Moment

Equivalent load F_E at impact

$$F_E = 1.4v_a \times \delta \times m \times g = 1.4 \times 700 \times \frac{1}{100} \times 6.525 \times 9.8 = 626.7 \text{ (N)}$$

M_{1E} : Moment

M_{1Emax} (from ε of graph MY1HT/M₁ where 1.4v_a = 980 mm/s) = 42.9 (N·m)

$$M_{1E} = \frac{1}{3} \times F_E \times Z = \frac{1}{3} \times 626.7 \times 37.4 \times 10^{-3} = 7.82 \text{ (N·m)}$$

Load factor α₃ = M_{1E}/M_{1Emax} = 7.82/42.9 = **0.18**

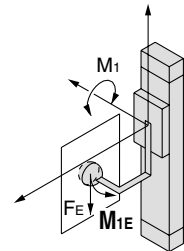

M_{3E} : Moment

M_{3Emax} (from (4) of graph MY1HT/M₃ where 1.4v_a = 980 mm/s) = 42.9 (N·m)

$$M_{3E} = \frac{1}{3} \times F_E \times Y = \frac{1}{3} \times 626.7 \times 29.6 \times 10^{-3} = 6.19 \text{ (N·m)}$$

Load factor α₄ = M_{3E}/M_{3Emax} = 6.19/42.9 = **0.14**

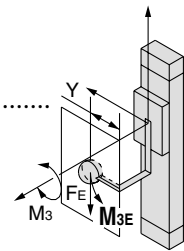

6. Sum and Examination of Guide Load Factors

$$\sum \alpha = \alpha_1 + \alpha_2 + \alpha_3 + \alpha_4 = \mathbf{0.39} \leq 1$$

The above calculation is within the allowable value, and therefore the selected model can be used.

Select a shock absorber separately.

In an actual calculation, when the total sum of guide load factors $\sum \alpha$ in the formula above is more than 1, consider either decreasing the speed, increasing the bore size, or changing the product series.

This calculation can be easily made using the “SMC Pneumatics CAD System”.

Allowable Moment

MY1HT/M₁

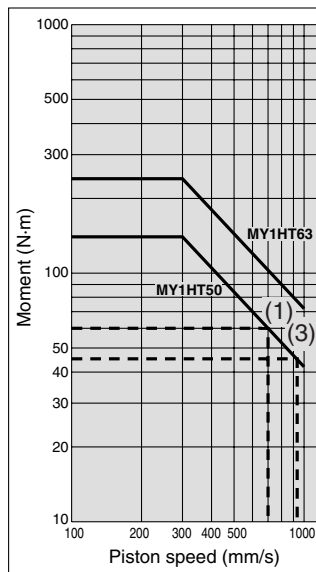

MY1HT/M₃

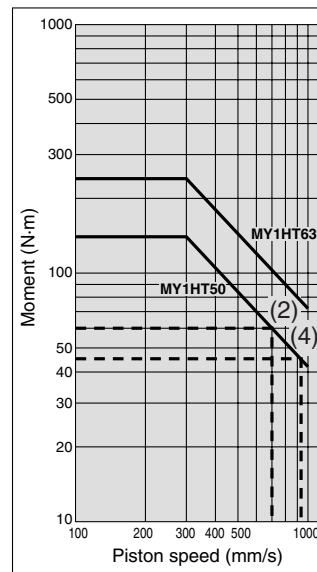

MX

MTS

MY

CY

MG

CX

D-

-X

20-

Data



Mechanically Jointed Rodless Cylinder High Rigidity/High Precision Guide Type Series **MY1HT** ø50, ø63

How to Order

MY1HT **50** **400** **L** **Y7BW**

High rigidity/high precision guide type
(2 linear guides)

Bore size (mm)

50	50 mm
63	63 mm

Piping

Nil	Standard type
G	Centralized piping type

Number of auto switches

Nil	2 pcs.
S	1 pc.
n	"n" pcs.

Auto switch

Nil	Without auto switch
-----	---------------------

* For the applicable auto switch model, refer to the table below.

* Auto switches are shipped together, (but not assembled).

Stroke

Refer to "Standard Stroke" on page 8-11-85.

Stroke adjusting unit

L	One shock absorber at each stroke end
H	Two shock absorbers at each stroke end
LH	One shock absorber at one end, two shock absorbers at one end

Option

Stroke Adjusting Unit Part No.

Bore size (mm)	50	63
Unit type	MYT-A50L	MYT-A63L

Side Support Part No.

Type \ Bore size (mm)	50	63
Side support A	MY-S63A	
Side support B	MY-S63B	

For details about dimensions, etc., refer to page 8-11-99.

Applicable Auto Switch/Refer to page 8-30-1 for further information on auto switches.

Type	Special function	Electrical entry	Indicator light	Wiring (Output)	Load voltage			Auto switch model		Lead wire length (m)*			Pre-wire connector	Applicable load	
					DC	AC		Perpendicular	In-line	0.5 (Nil)	3 (L)	5 (Z)		IC circuit	Relay, PLC
Reed switch	—	Grommet	Yes	3-wire (NPN equivalent)	—	5 V	—	—	Z76	●	●	—	—		
				2-wire	24 V	12 V	100 V	—	Z73	●	●	●	○	—	Relay, PLC
Solid state Switch	Diagnostic indication (2-color indication)	Grommet	Yes	3-wire (NPN)	24 V	5 V, 12 V	—	Y69A	Y59A	●	●	○	○	IC circuit	Relay, PLC
				3-wire (PNP)				Y7PV	Y7P	●	●	○	○		
				2-wire				Y69B	Y59B	●	●	○	○		
				3-wire (NPN)		5 V, 12 V		Y7NWV	Y7NW	●	●	○	○	IC circuit	
				3-wire (PNP)				Y7PWW	Y7PW	●	●	○	○		
				2-wire				Y7BWV	Y7BW	●	●	○	○	—	

* Lead wire length symbols: 0.5 m.....Nil (Example) Y59A
3 m.....L (Example) Y59AL
5 m.....Z (Example) Y59AZ

* Solid state switches marked with "○" are produced upon receipt of order.

* Separate switch spacers (BMP1-032) are required for retrofitting of auto switches.

• Since there are other applicable auto switches than listed, refer to page 8-11-101 for details.
• For details about auto switches with pre-wire connector, refer to page 8-30-52.

Mechanically Jointed Rodless Cylinder High Rigidity/High Precision Guide Type Series MY1HT

Specifications

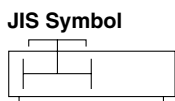

Bore size (mm)	50	63
Fluid	Air	
Action	Double acting	
Operating pressure range	0.1 to 0.8 MPa	
Proof pressure	1.2 MPa	
Ambient and fluid temperature	5 to 60°C	
Piston speed	100 to 1000 mm/s	
Cushion	Shock absorbers on both ends (Standard)	
Lubrication	Non-lube	
Stroke length tolerance	2700 or less ^{+1.8} ₀ , 2701 to 5000 ^{+2.8} ₀	
Port size	Side port	Rc 3/8

Note) Use at a speed within the absorption capacity range. Refer to page 8-11-96.

Stroke Adjusting Unit Specifications

Applicable bore size (mm)	50		63	
Unit symbol, contents	L	H	L	H
	RB2015 and adjusting bolt: 1 set each	RB2015 and adjusting bolt: 2 sets each	RB2725 and adjusting bolt: 1 set each	RB2725 and adjusting bolt: 2 sets each
Fine stroke adjustment range (mm)	0 to -20		0 to -25	
Stroke adjustment range	For adjustment method, refer to page 8-11-96.			

Shock absorber model	RB2015 x 1 pc.	RB2015 x 2 pcs.	RB2725 x 1 pc.	RB2725 x 2 pcs.
Maximum energy absorption (J)	58.8	88.2 ^{Note)}	147	220.5 ^{Note)}
Stroke absorption (mm)	15	15	25	25
Maximum collision speed (mm/s)	1000		1000	
Maximum operating frequency (cycle/min)	25	25	10	10
Spring force (N)	Extended	16.68	8.83	17.66
	Retracted	20.50	41.00	20.01
Operating temperature range (°C)	5 to 60			

Note) Maximum energy absorption for 2 pcs. is calculated by multiplying the value for 1 pc. by 1.5.

Theoretical Output

Bore size (mm)	Piston area (mm ²)	Operating pressure (MPa)						
		0.2	0.3	0.4	0.5	0.6	0.7	0.8
50	1962	392	588	784	981	1177	1373	1569
63	3115	623	934	1246	1557	1869	2180	2492

Note) Theoretical output (N) = Pressure (MPa) x Piston area (mm²)

Standard Stroke

Bore size (mm)	Standard stroke (mm) ^{Note)}	Maximum manufacturable stroke (mm)
50, 63	200, 400, 600, 800, 1000, 1500, 2000	5000

Note) Strokes other than standard are produced after receipt of order.

Weight

Bore size (mm)	Basic weight	Additional weight per each 25 mm of stroke	Side support weight (per set)	Stroke adjusting unit weight		
			Type A and B	L unit weight	LH unit weight	H unit weight
50	30.62	0.87	0.17	0.62	0.93	1.24
63	41.69	1.13	0.17	1.08	1.62	2.16

Calculation: (Example) MY1HT50-400L
 • Basic weight30.62 kg
 • Additional weight0.87/25 st
 • L unit weight0.62 kg
 • Cylinder stroke..... 400 st
 30.62 + 0.87 x 400 ÷ 25 + 0.62 x 2 = 45.8

Made to Order Specifications (For details, refer to page 8-31-1.)

Symbol	Specifications
-XB10	Intermediate stroke (Using exclusive body)
-XB11	Long stroke
-XC18	NPT finish piping port
-XC67	NBR rubber lining in dust seal band
-X168	Helical insert thread specifications

MX
 MTS
 MY
 CY
 MG
 CX
 D-
 -X
 20-
 Data

Series MY1HT

Cushion Capacity

Cushion Selection

<Stroke adjusting unit with built-in shock absorber>

L unit

Use this unit when the cylinder stroke is outside of the effective air cushion range even if the load and speed are within the air cushion limit line, or when the cylinder is operated in a load and speed range above the air cushion limit line or below the L unit limit line.

H unit

Use this unit when the cylinder is operated in a load and speed range above the L unit limit line and below the H unit limit line.

Stroke Adjusting Unit Absorption Capacity

MY1HT50 Horizontal collision: P = 0.5 MPa

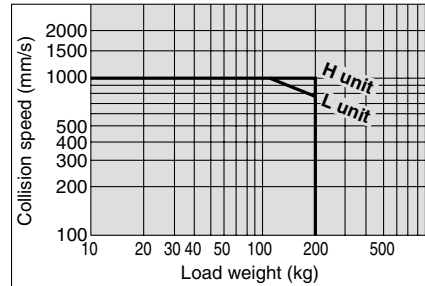

MY1HT63 Horizontal collision: P = 0.5 MPa

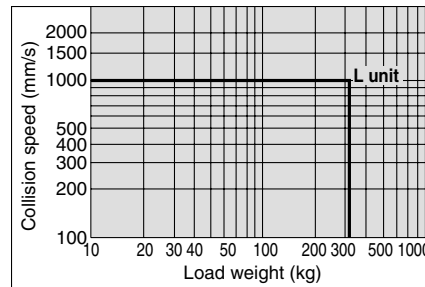

Stopper Bolt Holding Screw Tightening Torque

Stopper Bolt

Tightening Torque for Stroke Adjusting Unit Lock Plate Holding Bolts (N·m)

Bore size (mm)	Tightening torque
50	0.6
63	1.5

Calculation of Absorbed Energy for Stroke Adjusting Unit with Built-in Shock Absorber

(N·m)

Type of impact	Horizontal collision	Vertical (Downward)	Vertical (Upward)
Kinetic energy E ₁		$\frac{1}{2} m \cdot v^2$	
Thrust energy E ₂	F·s	F·s + m·g·s	F·s - m·g·s
Absorbed energy E		E ₁ + E ₂	

Symbol

v: Speed of impact object (m/s)

F: Cylinder thrust (N)

s: Shock absorber stroke (m)

m: Weight of impact object (kg)

g: Gravitational acceleration (9.8 m/s²)

Note) The speed of the impact object is measured at the time of impact with the shock absorber.

⚠ Precautions

Be sure to read before handling. Refer to pages 8-34-3 to 8-34-6 for Safety Instructions and Actuator Precautions.

Mounting

⚠ Caution

1. Do not apply strong impact or excessive moment to the slide table (slider).

Since the slide table (slider) is supported by precision bearings, do not subject it to strong impact or excessive moment when mounting workpieces.

2. Perform careful alignment when connecting to a load which has an external guide mechanism.

Mechanically jointed rodless cylinders can be used with a direct load within the allowable range for each type of guide, but careful alignment is necessary for connection to a load which has an external guide mechanism. Since fluctuation of the center axis increases as the stroke becomes longer, use a method of connection which can absorb the variations (floating mechanism).

3. Do not put hands or fingers inside when the body is suspended.

Since the body is heavy, use eye bolts when suspending it. (The eye bolts are not included with the body.)

Handling

⚠ Caution

1. Do not unnecessarily alter the guide adjustment setting.

The guide is preadjusted at the factory so that readjustment is not required under normal operating conditions. Do not inadvertently move the guide adjusting unit and change the setting.

Handling

⚠ Caution

2. Air leakage will result from negative pressure.

Take precautions under operating conditions in which negative pressure is increased inside the cylinder by external forces or inertial forces. Air leakage may occur due to separation of the seal belt.

Mounting of Auto Switch

⚠ Caution

1. Insert the auto switch into the cylinder's switch mounting groove, then slide it sideways in the direction shown below and place it inside the switch spacer (with the spacer positioned over it).
2. Use a flat head watchmakers' screwdriver to fasten the switch, tightening with a torque of 0.05 to 0.1 N·m. As a rule, it should be turned about 90° past the point at which tightening can be felt.

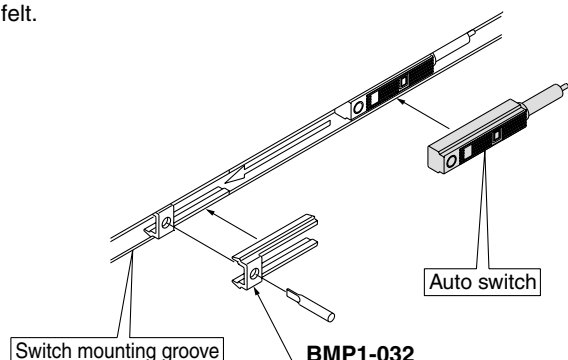

Stroke Adjustment Method

⚠ Caution

- As shown in Figure (1), to adjust the stopper bolt within the adjustment range A, insert a hexagon wrench from the top to loosen the hexagon socket head set screw by approximately one turn, and then adjust the stopper bolt with a flat head screwdriver.
- When the adjustment described in 1 above is insufficient, the shock absorber can be adjusted. Remove the covers as shown in Figure (2) and make further adjustment by loosening the hexagon nut.
- Various dimensions are indicated in Table (1). Never make an adjustment that exceeds the dimensions in the table, as it may cause an accident and/or damage.

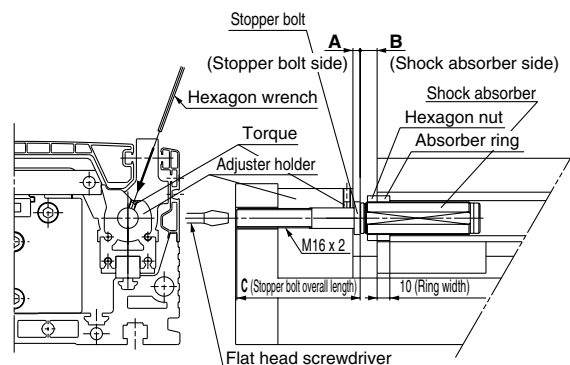

Figure (1) Stroke adjusting section detail

Table (1)

Bore size (mm)	50	63
A to A MAX	6 to 26	6 to 31
B to B MAX	14 to 54	14 to 74
C	87	102
Max. adjustment range	60	85

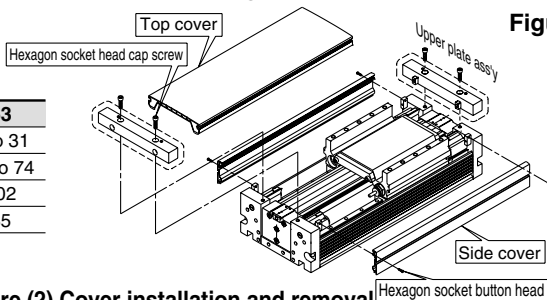

Figure (2) Cover installation and removal

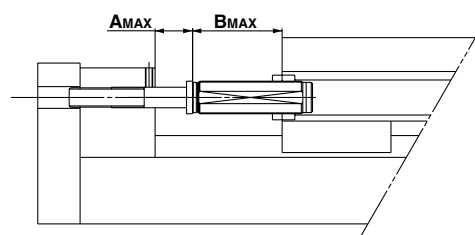

Figure (3) Maximum stroke adjustment detail

Disassembly and Assembly Procedure

⚠ Caution

Disassembly step

- Remove the hexagon socket head cap screws 1, and remove the upper plates.
- Remove the top cover.
- Remove the hexagon socket head cap screws 2, and remove the end covers and couplers.
- Remove the hexagon socket head cap screws 3.
- Remove the hexagon socket head cap screws 4, and remove the end supports.
- Remove the cylinder.

Assembly step

- Insert the MY1BH cylinder.
- Temporarily fasten the end supports with the hexagon socket head cap screws 4.
- With two hexagon socket head cap screws 3 on the L or R side, pull the end support and the cylinder.
- Tighten the hexagon socket head cap screws 3 on the other side to eliminate the looseness in the axial direction.
(At this point, a space is created between the end support and the end plate on one side, but this is not a problem.)
- Re-tighten the hexagon socket head cap screws 4.
- Fasten the end cover with the hexagon head cap screws 2, while making sure that the coupler is in the right direction.
- Place the top cover on the body.
- Insert the holding blocks into the top cover and fasten the upper plates with the hexagon socket head cap screws 1.

*** Cylinder For Driving (Series MY1BH)**

Since Series MY1BH is a cylinder for driving for Series MY1HT, its construction is different from Series MY1B. Do not use Series MY1B as a cylinder for driving, since it will lead to damage.

How to Order



Bore size (mm)	Piping	Stroke (mm)
50	Nil	Standard type
63	G	Centralized piping type

- MX
- MTS
- MY
- CY
- MG
- CX
- D-
- X
- 20-
- Data

Series MY1HT

Standard Type/Centralized Piping Type $\phi 50, \phi 63$

Refer to page 8-11-9 regarding centralized piping port variations.

MY1HT50□/63□ — Stroke

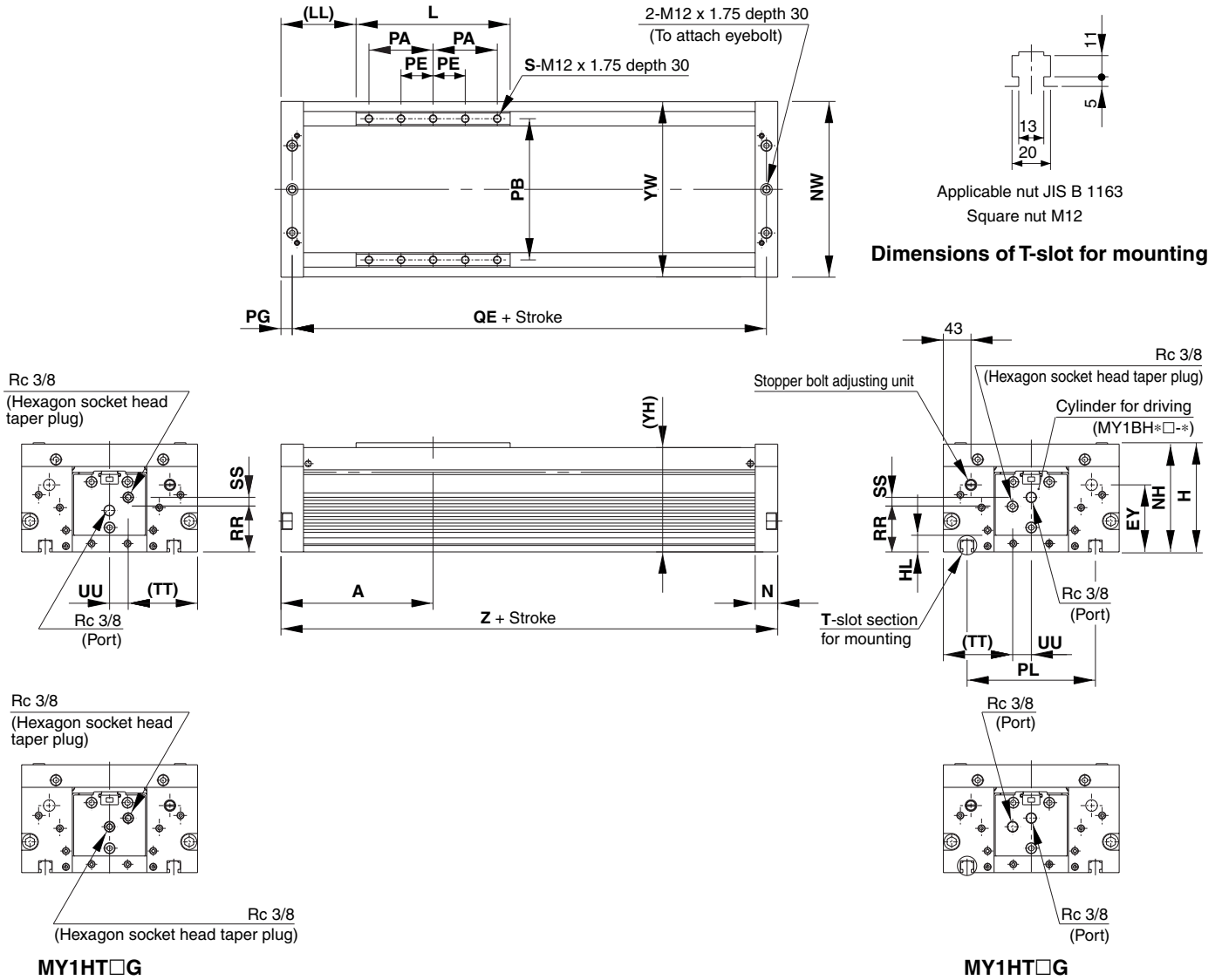

Model	A	EY	H	HL	L	LL	N	NH	NW	PA	PB	PE	PG
MY1HT50□	207	97.5	145	23	210	102	30	143	254	90	200	—	15
MY1HT63□	237	104.5	170	26	240	117	35	168	274	100	220	50	17.5

Model	PL	QE	RR	S	SS	TT	UU	YH	YW	Z
MY1HT50□	180	384	57	6	10	103.5	23.5	136.4	252	414
MY1HT63□	200	439	71.5	10	13.5	108	29	162.6	273	474

Side Support

Side support A MY-S63A

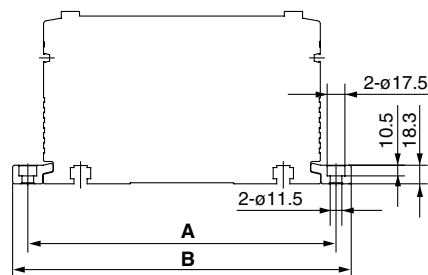
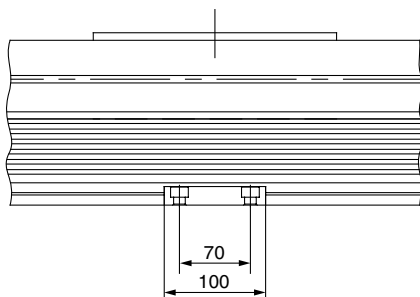

Side support B MY-S63B

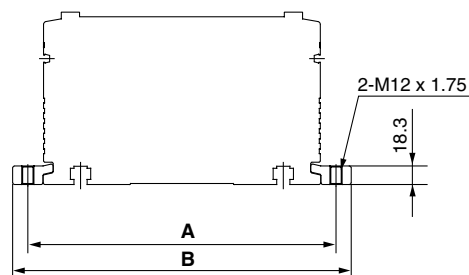
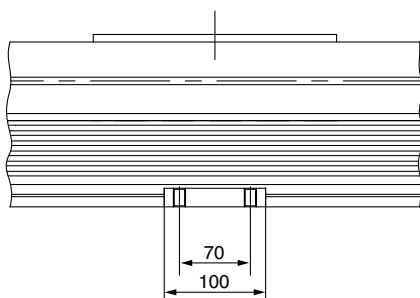

Dimensions

(mm)

Model	Applicable bore size	A	B
MY-S63 _A	MY1HT50	284	314
	MY1HT63	304	334

MX

MTS

MY

CY

MG

CX

D-

-X

20-

Data

Guide for Side Support Application

For long stroke operation, the cylinder tube may be deflected depending on its own weight and the load weight. In such a case, use a side support in the middle section. The spacing (l) of the support must be no more than the values shown in the graph on the right.

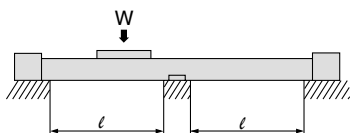
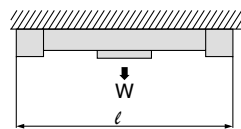
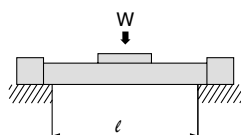

⚠ Caution

1. If the cylinder mounting surfaces are not measured accurately, using a side support may cause poor operation. Therefore, be sure to level the cylinder tube when mounting. Also, for long stroke operation involving vibration and impact, use of a side support is recommended even if the spacing value is within the allowable limits shown in the graph.
2. Support brackets are not for mounting; use them solely for providing support.

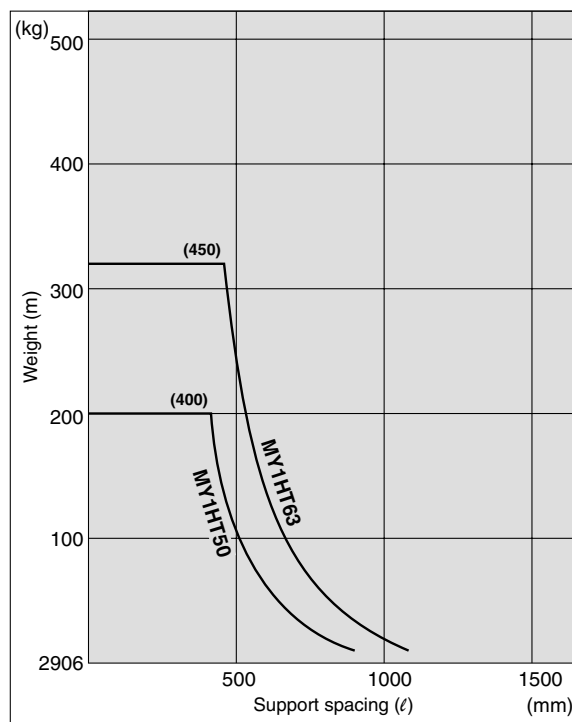

Series MY1HT

Construction

Standard type

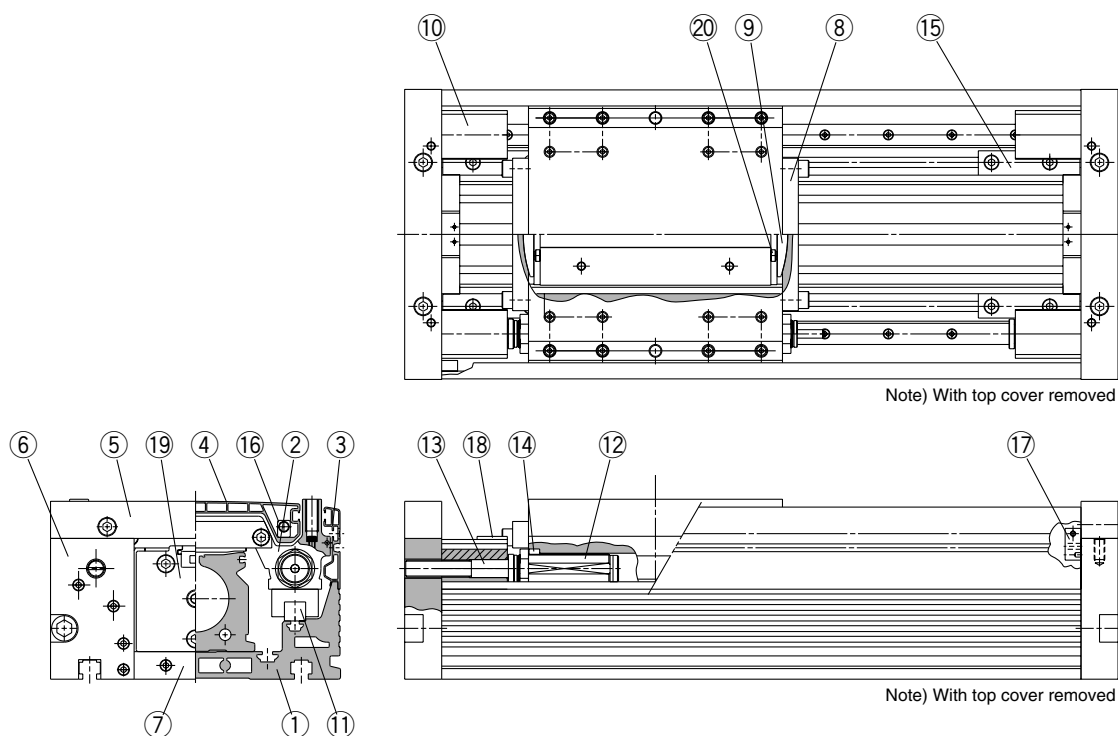

Component Parts

No.	Description	Material	Note
①	Guide frame	Aluminum alloy	Hard anodized
②	Slide table	Aluminum alloy	Hard anodized
③	Side cover	Aluminum alloy	Hard anodized
④	Top cover	Aluminum alloy	Hard anodized
⑤	Upper plate	Aluminum alloy	Hard anodized
⑥	End plate	Aluminum alloy	Hard anodized
⑦	Bottom plate	Aluminum alloy	Hard anodized
⑧	End cover	Aluminum alloy	Chromated
⑨	Coupler	Aluminum alloy	Chromated
⑩	Adjuster holder	Aluminum alloy	Hard anodized
⑪	Guide	—	
⑫	Shock absorber	—	
⑬	Stopper bolt	Carbon steel	Nickel plated
⑭	Absorber ring	Rolled steel	Nickel plated
⑮	End support	Aluminum alloy	Hard anodized
⑯	Top block	Aluminum alloy	Chromated
⑰	Side block	Aluminum alloy	Chromated
⑱	Slide plate	Special resin	
⑲	Rodless cylinder	—	MY1BH
⑳	Stopper	Carbon steel	Nickel plated

Series MY1

Auto Switch

D-A90(V), D-A93(V), D-A96(V)



Applicable cylinder series

Applicable cylinder series	Bore size (mm)									
	10	16	20	25	32	40	50	63	80	100
MY1B (Basic type)	●	●	●							
MY1M (Slide bearing type)		●	●							
MY1C (Cam follower guide type)		●	●							
MY1H (High precision guide type)	●	●	●							

D-Z73, D-Z76, D-Z80



Applicable cylinder series

Applicable cylinder series	Bore size (mm)									
	16	20	25	32	40	50	63	80	100	
MY1B (Basic type)			●	●	●	●	●	●	●	●
MY1M (Slide bearing type)			●	●	●	●	●	●	●	●
MY1C (Cam follower guide type)			●	●	●	●	●	●	●	●
MY1H (High precision guide type)			●	●	●					
MY1HT (High rigidity/High precision guide type)						●	●			

D-M9N(V), D-M9P(V), D-M9B(V)



Applicable cylinder series

Applicable cylinder series	Bore size (mm)									
	10	16	20	25	32	40	50	63	80	100
MY1B (Basic type)	●	●	●							
MY1M (Slide bearing type)		●	●							
MY1C (Cam follower guide type)		●	●							
MY1H (High precision guide type)	●	●	●							

D-F9NW(V), D-F9PW(V), D-F9BW(V)

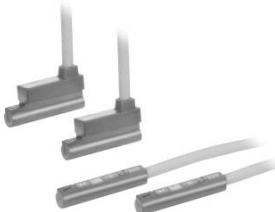

Applicable cylinder series

Applicable cylinder series	Bore size (mm)									
	10	16	20	25	32	40	50	63	80	100
MY1B (Basic type)	●	●	●							
MY1M (Slide bearing type)		●	●							
MY1C (Cam follower guide type)		●	●							
MY1H (High precision guide type)	●	●	●							

D-Y59^A_B, D-Y69^A_B, D-Y7P(V)



Applicable cylinder series

Applicable cylinder series	Bore size (mm)									
	16	20	25	32	40	50	63	80	100	
MY1B (Basic type)			●	●	●	●	●	●	●	●
MY1M (Slide bearing type)			●	●	●	●	●	●	●	●
MY1C (Cam follower guide type)			●	●	●	●	●	●	●	●
MY1H (High precision guide type)			●	●	●					
MY1HT (High rigidity/High precision guide type)						●	●			

D-Y7NW(V), D-Y7PW(V), D-Y7BW(V)

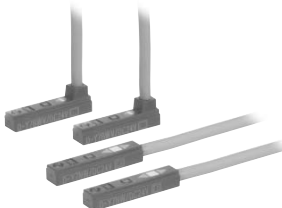

Applicable cylinder series

Applicable cylinder series	Bore size (mm)									
	16	20	25	32	40	50	63	80	100	
MY1B (Basic type)			●	●	●	●	●	●	●	●
MY1M (Slide bearing type)			●	●	●	●	●	●	●	●
MY1C (Cam follower guide type)			●	●	●	●	●	●	●	●
MY1H (High precision guide type)			●	●	●					
MY1HT (High rigidity/High precision guide type)						●	●			

Other than the applicable auto switches listed in "How to Order", the following auto switches can be mounted. For detailed specifications, refer to page 8-30-1.

Type	Model	Electrical entry (Fetching direction)	Features
Reed switch	D-A90	Grommet (In-line)	Without indicator light
	D-Z80	Grommet (In-line)	

- Normally closed (NC = b contact), solid state switch (D-F9G/F9H/Y7G/Y7H type) are also available. For details, refer to page 8-30-31 to 8-30-32.
- D-A90 cannot be mounted on Series MY1HT.

MX

MTS

MY

CY

MG

CX

D-

-X

20-

Data

Series MY1

Proper Auto Switch Mounting Position (Detection at stroke end) D-A9□(V)

Note) The operating range is a guide including hysteresis, but is not guaranteed. (Assuming approximately 30% dispersion.) There may be varied substantially depending on the surrounding environment.

MY1B (Basic type)

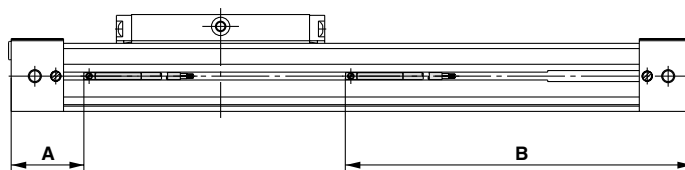

(mm)			
Mounting position	ø10	ø16	ø20
A	20	27	35
B	90	133	165
Operating range l (Note)	6	6.5	8.5

MY1M (Slide bearing guide type)

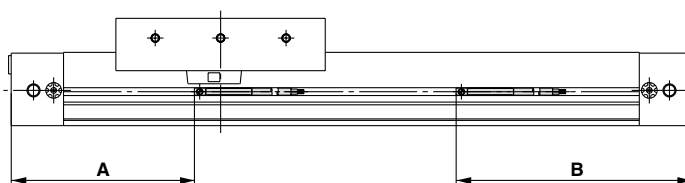

(mm)		
Mounting position	ø16	ø20
A	70	90
B	90	110
Operating range l (Note)	11	7.5

MY1C (Cam follower guide type)

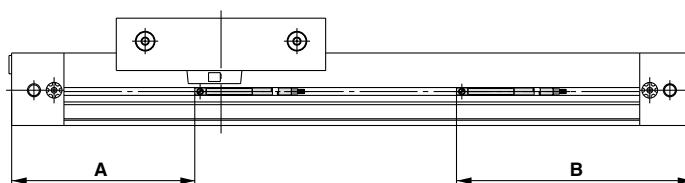

(mm)		
Mounting position	ø16	ø20
A	70	90
B	90	110
Operating range l (Note)	11	7.5

MY1H (High precision guide type)

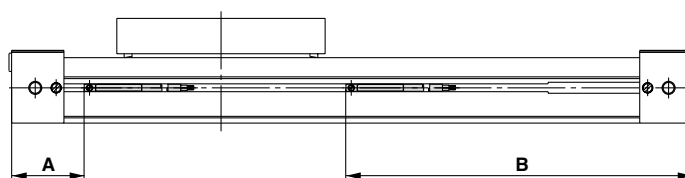

(mm)			
Mounting position	ø10	ø16	ø20
A	20	27	35
B	90	133	165
Operating range l (Note)	11	6.5	8.5

Proper Auto Switch Mounting Position (Detection at stroke end) D-Z7□, D-Z80

(Note) The operating range is a guide including hysteresis, but is not guaranteed. (Assuming approximately 30% dispersion). There may be varied substantially depending on the surrounding environment.

MY1B (Basic type)

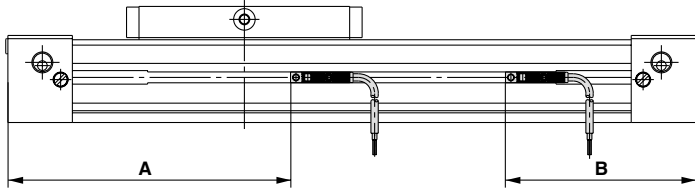

(mm)							
Mounting position	ø25	ø32	ø40	ø50	ø63	ø80	ø100
A	131.5	180	216	272.5	317.5	484.5	569.5
B	88.5	100	124	127.5	142.5	205.5	230.5
Operating range ℓ (Note)	8.5	11.5	11.5	11.5	11.5	11.5	11.5

MY1M (Slide bearing guide type)

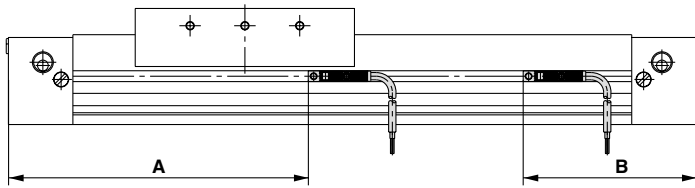

(mm)					
Mounting position	ø25	ø32	ø40	ø50	ø63
A	139.5	184.5	229.5	278.5	323.5
B	80.5	95.5	110.5	121.5	136.5
Operating range ℓ (Note)	12	12	12	11.5	11.5

MY1C (Cam follower guide type)

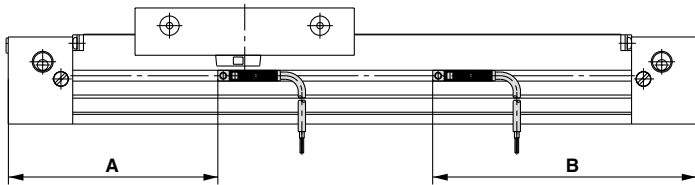

(mm)					
Mounting position	ø25	ø32	ø40	ø50	ø63
A	97.5	127.5	157.5	278.5	323.5
B	122.5	152.5	182.5	121.5	136.5
Operating range ℓ (Note)	12	12	12	11.5	11.5

MY1H (High precision guide type)

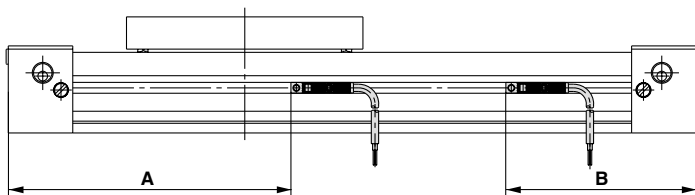

(mm)			
Mounting position	ø25	ø32	ø40
A	131.5	180	216
B	88.5	100	124
Operating range ℓ (Note)	8.5	11.5	11.5

MY1HT (High rigidity/High precision guide type)

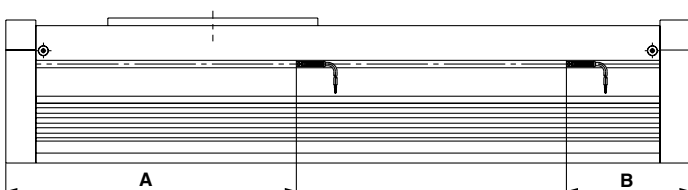

(mm)		
Mounting position	ø50	ø63
A	290.5	335.5
B	123.5	138.5
Operating range ℓ (Note)	11	11

MX□

MTS

MY□

CY□

MG□

CX□

D-

-X

20-

Data

Series MY1

Proper Auto Switch Mounting Position (Detection at stroke end) D-M9□, D-M9□V, D-F9□W, D-F9□WV

Note) The operating range is a guide including hysteresis, but is not guaranteed. (assuming approximately 30% dispersion.) There may be varied substantially depending on the surrounding environment.

MY1B (Basic type)

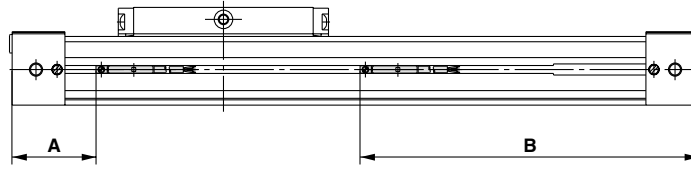

(mm)

Mounting position	ø10	ø16	ø20
A	24	31	39
B	86	129	161
Operating range ℓ ^{Note)}	3 (2.5)	4 (3)	5 (3.5)

Note) Figures in parentheses are the cases for D-M9□, D-M9□V switch types.

MY1M (Slide bearing guide type)

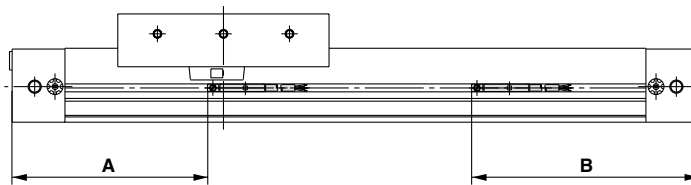

(mm)

Mounting position	ø16	ø20
A	74	94
B	86	106
Operating range ℓ ^{Note)}	8.5 (6.5)	6.5 (7)

Note) Figures in parentheses are the cases for D-M9□, D-M9□V switch types.

MY1C (Cam follower guide type)

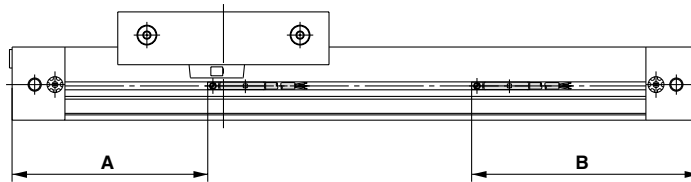

(mm)

Mounting position	ø16	ø20
A	74	94
B	86	106
Operating range ℓ ^{Note)}	8.5 (6.5)	6.5 (7)

Note) Figures in parentheses are the cases for D-M9□, D-M9□V switch types.

MY1H (High precision guide type)

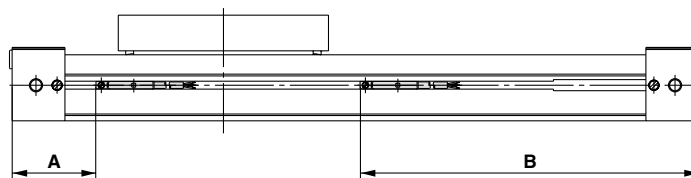

(mm)

Mounting position	ø10	ø16	ø20
A	24	31	39
B	86	129	161
Operating range ℓ ^{Note)}	3 (2)	4 (3)	5 (3.5)

Note) Figures in parentheses are the cases for D-M9□, D-M9□V switch types.

Proper Auto Switch Mounting Position (Detection at stroke end) D-Y59□, D-Y69□, D-Y7P, D-Y7PV

Note) The operating range is a guide including hysteresis, but is not guaranteed. (Assuming approximately 30% dispersion.) There may be varied substantially depending on the surrounding environment.

MY1B (Basic type)

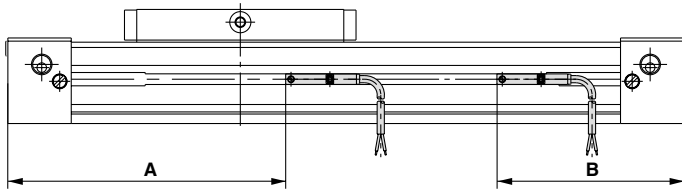

(mm)							
Mounting position	ø25	ø32	ø40	ø50	ø63	ø80	ø100
A	131.5	180	216	272.5	317.5	484.5	569.5
B	88.5	100	124	127.5	142.5	205.5	230.5
Operating range l (Note)	6	9	10	3.5	3.5	3.5	3.5

MY1M (Slide bearing guide type)

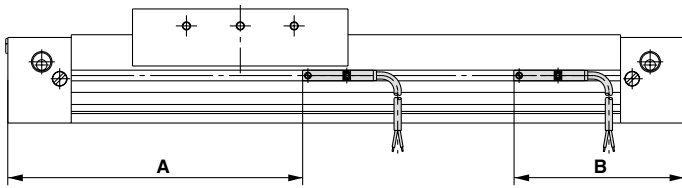

(mm)					
Mounting position	ø25	ø32	ø40	ø50	ø63
A	139.5	184.5	229.5	278.5	323.5
B	80.5	95.5	110.5	121.5	136.5
Operating range l (Note)	5	5	5	5.5	5.5

MY1C (Cam follower guide type)

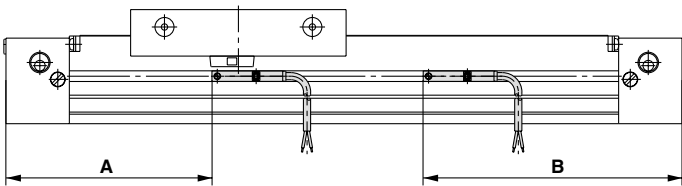

(mm)					
Mounting position	ø25	ø32	ø40	ø50	ø63
A	97.5	127.5	157.5	278.5	323.5
B	122.5	152.5	182.5	121.5	136.5
Operating range l (Note)	5	5	5	5.5	5.5

MY1H (High precision guide type)

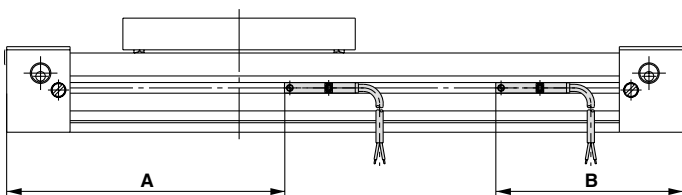

(mm)			
Mounting position	ø25	ø32	ø40
A	131.5	180	216
B	88.5	100	124
Operating range l (Note)	6	9	10

MY1HT (High rigidity/High precision guide type)

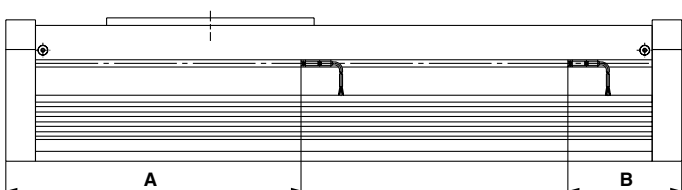

(mm)		
Mounting position	ø50	ø63
A	290.5	335.5
B	123.5	138.5
Operating range l (Note)	5	5

MX□

MTS

MY□

CY□

MG□

CX□

D-

-X

20-

Data

Series MY1

Proper Auto Switch Mounting Position (Detection at stroke end) D-Y7□W, D-Y7□WV

Note) The operating range is a guide including hysteresis, but is not guaranteed. (Assuming approximately 30% dispersion.) There may be varied substantially depending on the surrounding environment.

MY1B (Basic type)

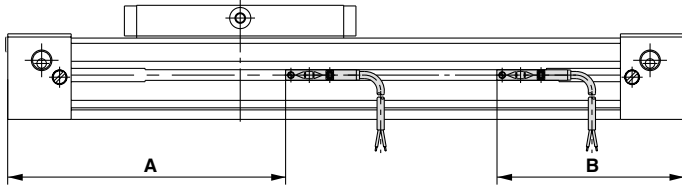

(mm)							
Mounting position	ø25	ø32	ø40	ø50	ø63	ø80	ø100
A	131.5	180	216	272.5	317.5	484.5	569.5
B	88.5	100	124	127.5	142.5	205.5	230.5
Operating range l (Note)	6	9	10	3.5	3.5	3.5	3.5

MY1M (Slide bearing guide type)

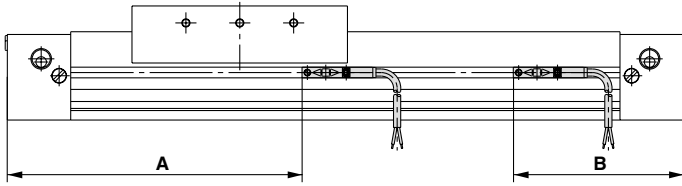

(mm)					
Mounting position	ø25	ø32	ø40	ø50	ø63
A	139.5	184.5	229.5	278.5	323.5
B	80.5	95.5	110.5	121.5	136.5
Operating range l (Note)	5	5	5	5.5	5.5

MY1C (Cam follower guide type)

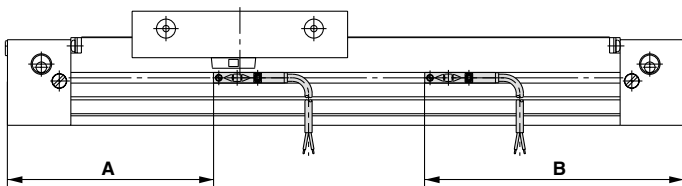

(mm)					
Mounting position	ø25	ø32	ø40	ø50	ø63
A	97.5	127.5	157.5	278.5	323.5
B	122.5	152.5	182.5	121.5	136.5
Operating range l (Note)	5	5	5	5.5	5.5

MY1H (High precision guide type)

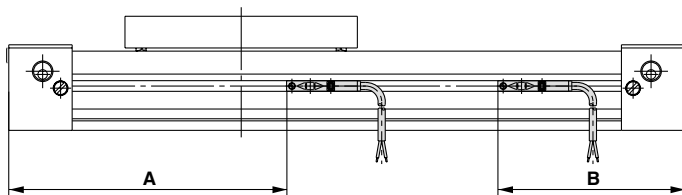

(mm)			
Mounting position	ø25	ø32	ø40
A	131.5	180	216
B	88.5	100	124
Operating range l (Note)	6	9	10

MY1HT (High rigidity/High precision guide type)

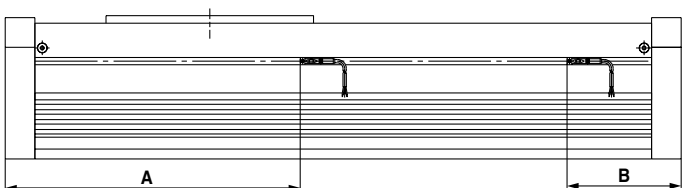

(mm)		
Mounting position	ø50	ø63
A	290.5	335.5
B	123.5	138.5
Operating range l (Note)	5	5



Mechanically Jointed Rodless Cylinder With Protective Cover

Series MY1□W

ø16, ø20, ø25, ø32, ø40, ø50, ø63

Protective cover offers excellent dust and water resistance

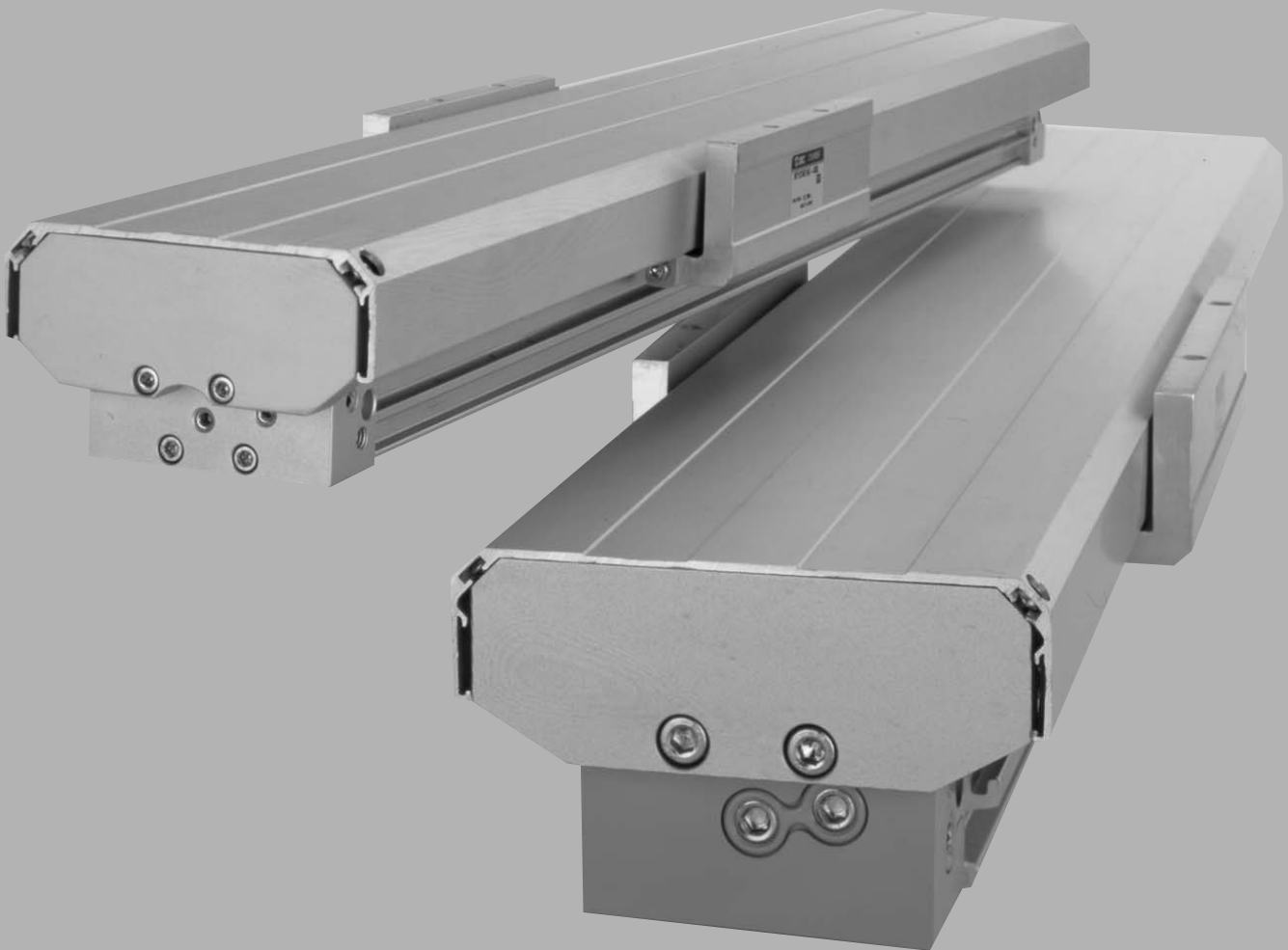

MX□

MTS

MY□

CY□

MG□

CX□

D-

-X

20-

Data

Series Variations

Series	Guide type	Cover	Bore size (mm)							Option
			16	20	25	32	40	50	63	
MY1MW	Slide bearing	With protective cover	●	●	●	●	●	●	●	<ul style="list-style-type: none"> • Centralized piping • Stroke adjusting unit • Side support
MY1MWK		With protective cover With side seal	●	●	●	●	●			
MY1CW	Cam follower guide	With protective cover	●	●	●	●	●	●	●	
MY1CWK		With protective cover With side seal	●	●	●	●	●			

Series MY1□W

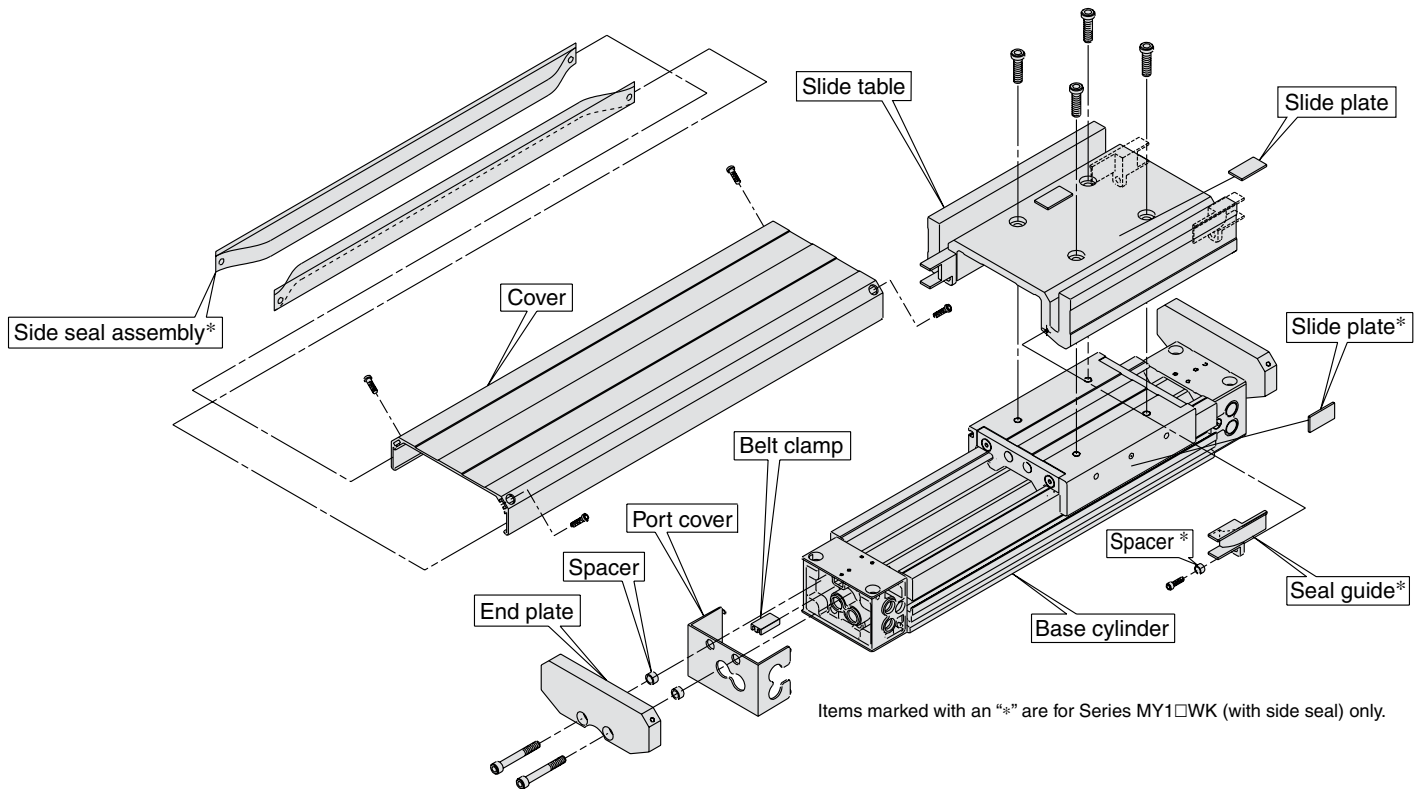

1 Dustproof and water resistant features are improved for using in locations where the cylinder is exposed to power dust and water drop or splash.

2 Side seals provide greater lateral dustproof and water resistance.

3 The cover in no way interferes with the installation of base cylinder option.

4 Cover units and side seal units can be installed on the already existing Series MY1M/MY1C.

5 Protective cover only minimally adds to overall length.

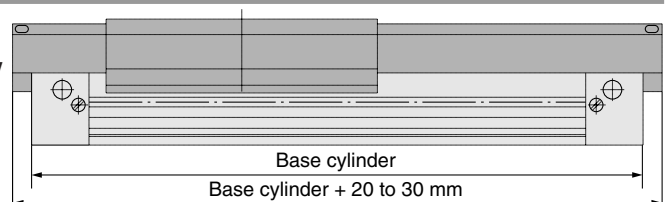

6 Water-resistant solid state switches can be mounted onto the $\varnothing 25$ to $\varnothing 40$ models.



Series MY1□W

Specific Product Precautions 1

Be sure to read before handling.

Mounting

⚠ Caution

1. To obtain the best results from the cover, horizontal mounting is recommended.

- With horizontal mounting (shown below), the entry of dirt and dust from the bottom of the cover is much less compared to other mounting orientations, making it much more efficient.

Horizontal mounting

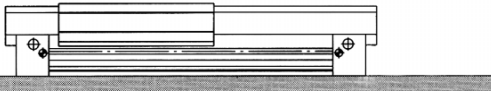

2. When the cylinder is mounted from the top side or when strokes are to be adjusted by installing a stroke adjusting unit, the protective cover must be removed for these purposes.

- For detailed assembly step, refer to page 8-12-4.

⚠ Caution

Centralized Piping Port Variations

- Head cover piping connection can be freely selected to best suit different piping conditions.

Operating Environment

⚠ Caution

2. Because of floating particles such as paper dust and coolant mist that may enter the inside of the cover.

- Since there is a gap between the bottom of the cover and cylinder tube, take precautions when operating cylinders in environments where there is exposure to excessive amount of floating particles, water/oil splash, or chip spattering. If they enter inside the cover, malfunction may occur.

MX□

MTS

MY□

CY□

MG□

CX□

D-

-X

20-

Data

Applicable cylinder	Port variations
MY1MW16/20/50/63 MY1CW16/20/50/63	<p>This port is not available for use. (Except ø50)</p> <p>Slide table operating direction</p>
MY1MW25/32/40 MY1CW25/32/40	<p>This port is not available for use. (Except ø32, ø40)</p> <p>Slide table operating direction</p>



Series MY1□W

Specific Product Precautions 2

Be sure to read before handling.

Assembly Procedure

1. Component check

Check the components.

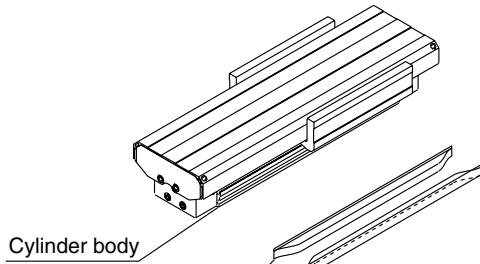

Side seal assembly
(Applies to models that come with side seal only)

Note) When auto switches are included with a cylinder order, they are packaged together with the cylinder.

2. Removal of cover

Remove the hexagon socket head button bolts and cover.

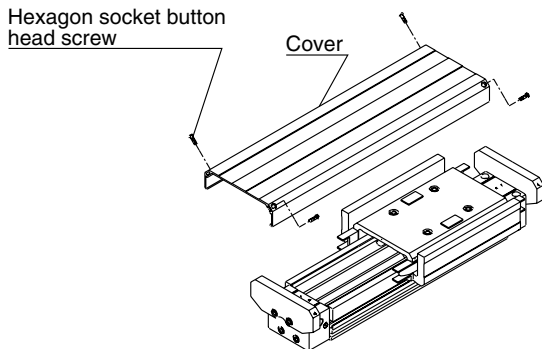

3. Body mounting/adjustment

Mount the cylinder body.

For cylinders with protective cover only (i.e., without side seal), reinstall the cover after the cylinder is mounted and adjusted. (Refer to Step 6 "Cover installation".)

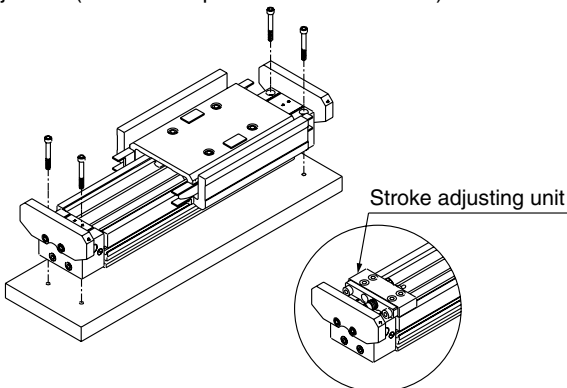

Note) The adjustment of the stroke adjusting unit (optional) should also be done at this time.

4. Temporary cover installation

- 1) Remove the hexagon socket head cap screws and one of the end plates.
- 2) Place the cover and temporarily secure it with the hexagon socket button head bolts.

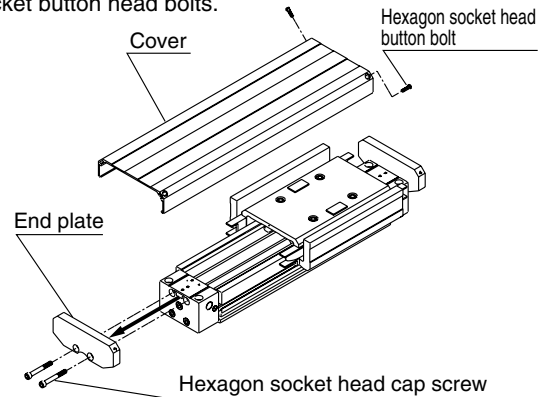

5. Side seal installation

Slide the side seal assembly into the place from one end of the cylinder.

Stainless steel portions of the side seal assembly are very sharp. Take extra precautions when handling.

Note) Move the slide table to the end of the insertion side.

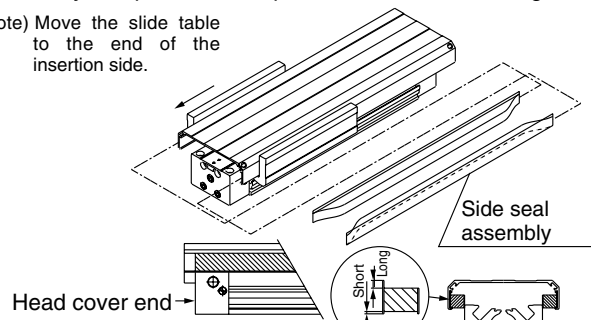

Note) Slide the side seal all the way to the end of the head cover.

Note) Make sure the side seal assembly is facing in the right direction.

6. Cover installation

Reinstall the end plate and secure it.

Hexagon socket button head screw

Cover tightening torque [N·m]

Bore (mm)	Thread size	Torque
16 to 40	M3	0.6
50, 63	M4	1.4

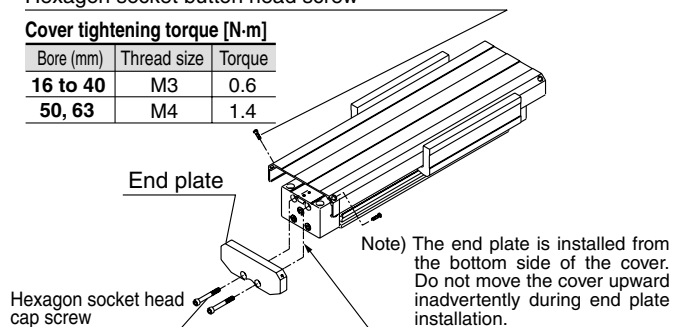

End plate tightening torque [N·m]

Bore (mm)	Thread size	Torque
16	M3	0.6
20	M4	1.4
25	M5	2.8
32	M6	4.8
40	M6	4.8
50	M8	12
63	M10	24

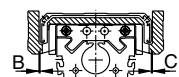

Note) If there is no gap (clearance) between the slide table and cover (B, C in the drawing above) throughout the stroke range, loosen the hexagon socket head cap screw to readjust the cover, then retighten it.

Model Selection 1

This section illustrates the standard model selection procedure to help you choose the most suitable cylinders from Series MY1MW/MY1CW for your application needs.

Standards for Tentative Model Selection

Cylinder model	Guide type	Standards for guide selection	Graphs for related allowable values
MY1MW	Slide bearing guide	Slide table accuracy approx. $\pm 0.12 \text{ mm}^2$	P. 8-12-8
MY1CW	Cam follower guide type	Slide table accuracy approx. $\pm 0.05 \text{ mm}^2$	P. 8-12-9

Note 1) These accuracy values for each guide should be used only as a guide during selection. Please contact SMC when guaranteed accuracy for MY1CW is required.

Note 2) "Accuracy" here means displacement of the slide table (at stroke end) when 50% of the allowable moment shown in the catalog is applied. (reference value).

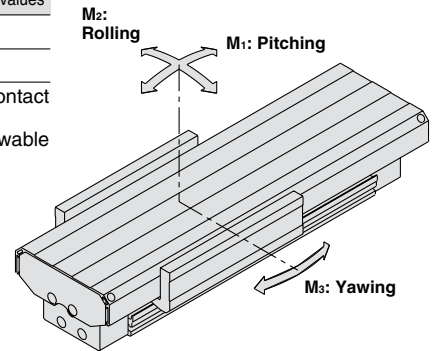

- MX□
- MTS
- MY□
- CY□
- MG□
- CX□
- D-
- X
- 20-
- Data

Selection Flow Chart

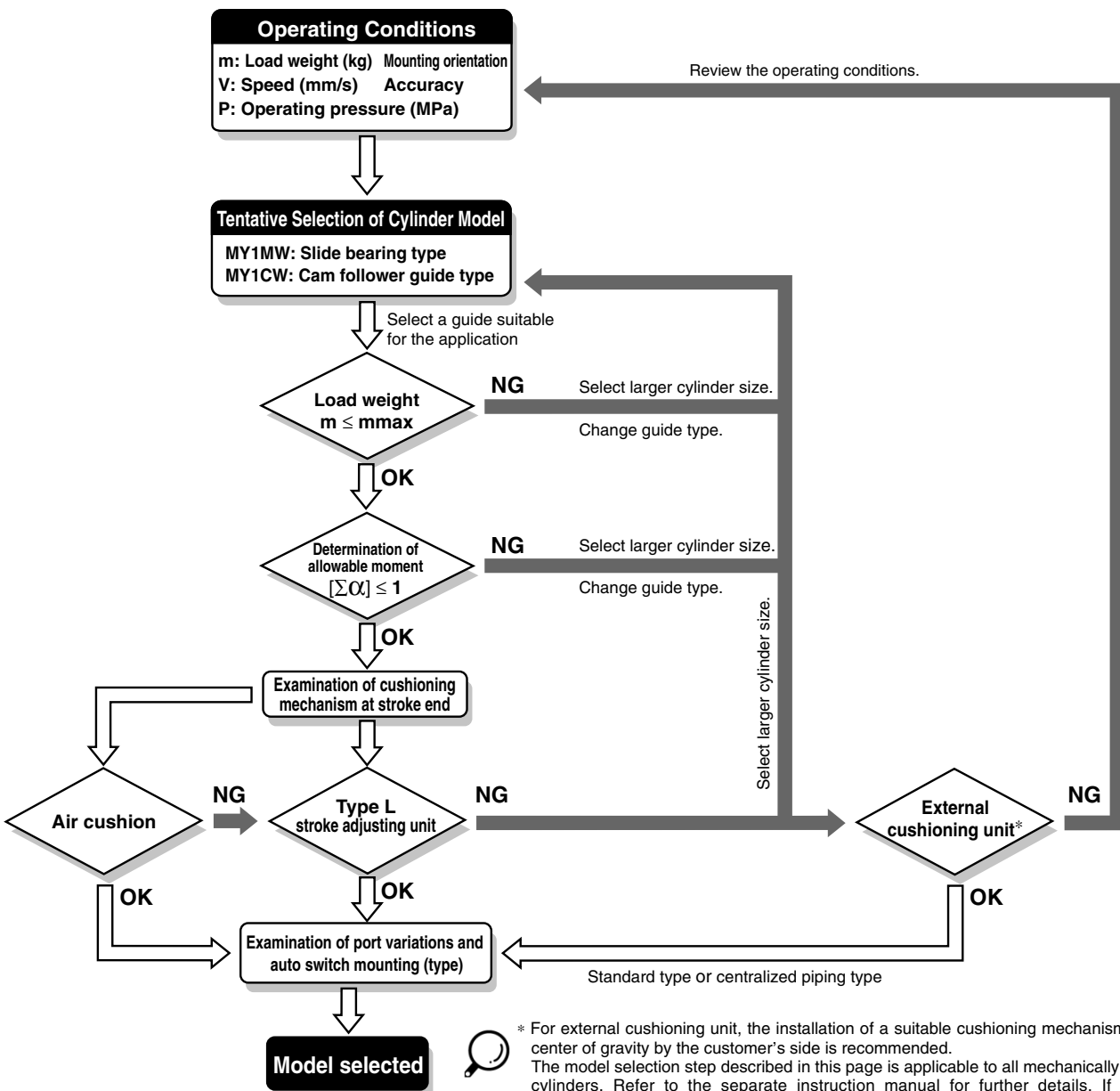

* For external cushioning unit, the installation of a suitable cushioning mechanism near the load center of gravity by the customer's side is recommended. The model selection step described in this page is applicable to all mechanically jointed rodless cylinders. Refer to the separate instruction manual for further details. If you have any questions, please contact SMC.

Types of Moment Applied to Rodless Cylinders

Multiple moments may be generated depending on the mounting orientation, load, and position of the center of gravity.

Coordinates and Moments

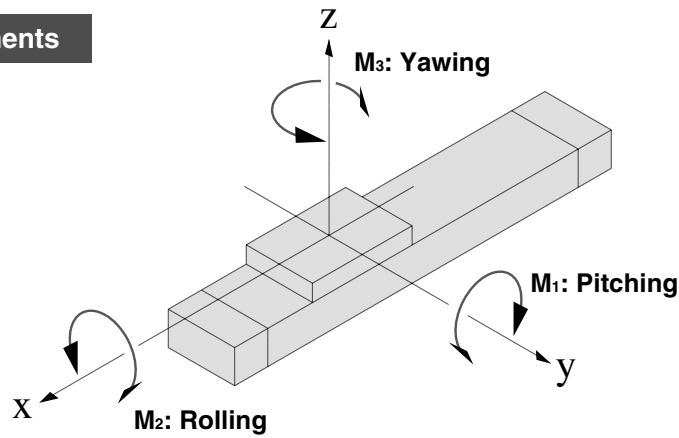

Static Moment

Horizontal mounting

Ceiling mounting

Wall mounting

Vertical mounting

g: Gravitational acceleration

Mounting orientation	Horizontal mounting	Ceiling mounting	Wall mounting	Vertical mounting
Static load (m)	m_1	m_2	m_3	m_4 <small>Note</small>
Static moment	M_1	M_2	M_3	
	$m_1 \times g \times X$	$m_2 \times g \times X$	—	$m_4 \times g \times Z$
	$m_1 \times g \times Y$	$m_2 \times g \times Y$	$m_3 \times g \times Z$	—
	—	—	$m_3 \times g \times X$	$m_4 \times g \times Y$

Note) "m" is a weight movable by thrust. Use 0.3 to 0.7 times the thrust (varies depending on the operating speed) as a guide for actual use.

Dynamic Moment

Mounting orientation	Horizontal mounting	Ceiling mounting	Wall mounting	Vertical mounting
Dynamic load F_E	$\frac{1.4}{100} \times v_a \times m_n \times g$			
Adjusting bolt	M_{1E}	$\frac{1}{3} \times F_E \times Z$		
	M_{2E}	Dynamic moment M_{2E} is not generated.		
	M_{3E}	$\frac{1}{3} \times F_E \times Y$		

Note) Regardless of the mounting orientation, dynamic moment is calculated using the formulas above.

g: Gravitational acceleration, v_a : Average speed

Maximum Allowable Moment/Maximum Load Weight

Model	Bore size (mm)	Maximum allowable moment (N·m)			Maximum load weight (kg)		
		M ₁	M ₂	M ₃	m ₁	m ₂	m ₃
MY1MW	16	6.0	3.0	1.0	18	7	2.1
	20	10	5.2	1.7	26	10.4	3
	25	15	9.0	2.4	38	15	4.5
	32	30	15	5.0	57	23	6.6
	40	59	24	8.0	84	33	10
	50	115	38	15	120	48	14
MY1CW	16	6.0	3.0	2.0	18	7	2.1
	20	10	5.0	3.0	25	10	3
	25	15	8.5	5.0	35	14	4.2
	32	30	14	10	49	21	6
	40	60	23	20	68	30	8.2
	50	115	35	35	93	42	11.5
	63	150	50	50	130	60	16

The above values are the maximum allowable values for moment and load. Refer to each graph regarding the maximum allowable moment and maximum allowable load for a particular piston speed.

Load weight (kg)

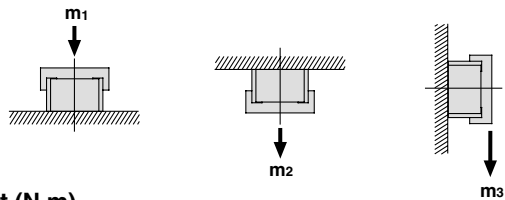

Caution

- The cylinder should be mounted in m1 orientation if maximum dustproofing is required.

Moment (N·m)

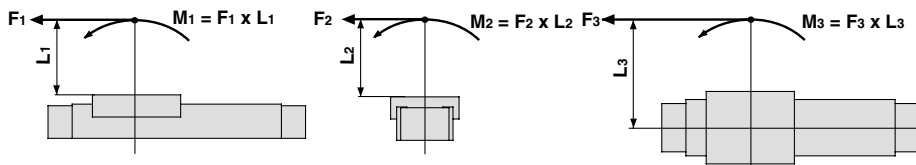

<Calculation of guide load factor>

- Three factors must be considered when computing calculations for selection: (1) Maximum load weight, (2) Static moment, (3) Dynamic moment (at the time of impact with stopper).
* To evaluate, use \bar{v}_a (average speed) for (1) and (2), and v (collision speed $v = 1.4 \bar{v}_a$) for (3). Calculate m_{max} for (1) from the maximum allowable load graph (m_1 , m_2 , and m_3), and M_{max} for (2) and (3) from the maximum allowable moment graph (M_1 , M_2 , and M_3).

$$\text{Sum of guide load factors } \sum \alpha = \frac{\text{Load weight [m]}}{\text{Maximum allowable load [m}_{max}\text{]}} + \frac{\text{Static moment [M] }^{Note\ 1}}{\text{Allowable static moment [M}_{max}\text{]}} + \frac{\text{Dynamic moment [ME] }^{Note\ 2}}{\text{Allowable dynamic moment [ME}_{max}\text{]}} \leq 1$$

Note 1) Moment caused by the load, etc., with cylinder in resting condition.

Note 2) Moment caused by the impact load equivalent at the stroke end (at the time of impact with stopper).

Note 3) Depending on the shape of the workpiece, multiple moments may occur. When this happens, the sum of the load factors ($\sum \alpha$) is the total of all such moments.

2. Reference formula [Dynamic moment at impact]

Use the following formulae to calculate dynamic moment when taking stopper impact into consideration.

- m: Load weight (kg)
- F: Load (N)
- F_E: Load equivalent to impact (at impact with stopper) (N)
- \bar{v}_a : Average speed (mm/s)
- M: Static moment (N·m)
- v: Collision speed (mm/s)
- L₁: Distance to the load's center of gravity (m)
- M_E: Dynamic moment (N·m)
- g: Gravitational acceleration (9.8 m/s²)

$$v = 1.4 \bar{v}_a \text{ (mm/s)} \quad F_E = \frac{1.4}{100} \bar{v}_a \cdot g \cdot m \text{ (Note 4)}$$

$$\therefore M_E = \frac{1}{3} F_E \cdot L_1 = 0.05 \bar{v}_a \cdot m \cdot L_1 \text{ (N·m)}$$

Note 4) $\frac{1.4}{100} \bar{v}_a$ is a dimensionless coefficient for calculating impact force.

Note 5) Average load coefficient ($= \frac{1}{3}$): This coefficient is for averaging the maximum load moment at the time of stopper impact according to service life calculations.

- For detailed selection procedures, refer to pages 8-11-12 to 8-11-13.

Maximum Allowable Moment

Select the moment from within the range of operating limits shown in the graphs. Note that the maximum allowable load value may sometimes be exceeded even within the operating limits shown in the graphs. Therefore, also check the allowable load for the selected conditions.

Maximum Load Weight

Select the load from within the range of limits shown in the graphs. Note that the maximum allowable moment value may sometimes be exceeded even within the operating limits shown in the graphs. Therefore, also check the allowable moment for the selected conditions.

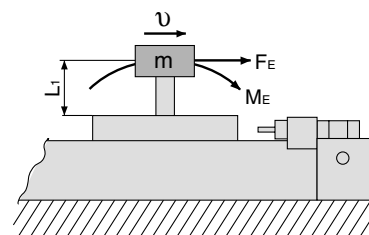

Series MY1□W

Maximum Allowable Moment/Maximum Load Weight

Maximum Allowable Moment: MY1MW

MY1MW/M₁

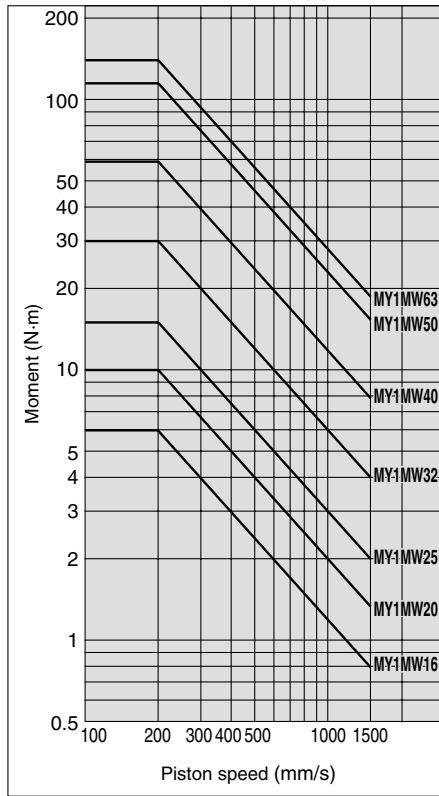

MY1MW/M₂

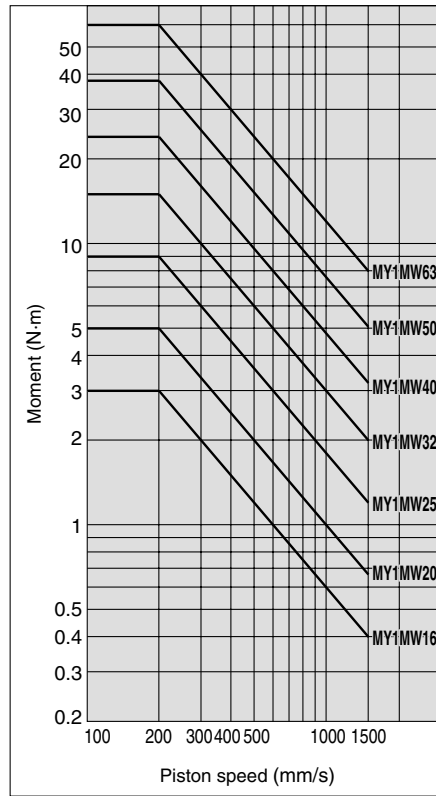

MY1MW/M₃

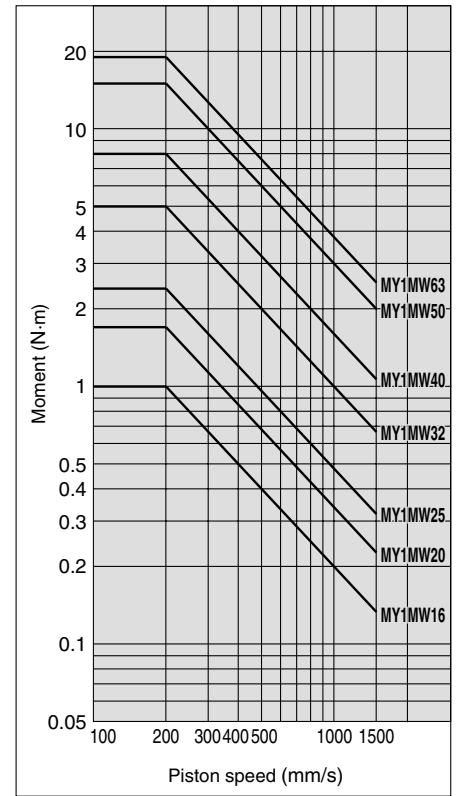

Maximum Load Weight: MY1MW

MY1MW/m₁

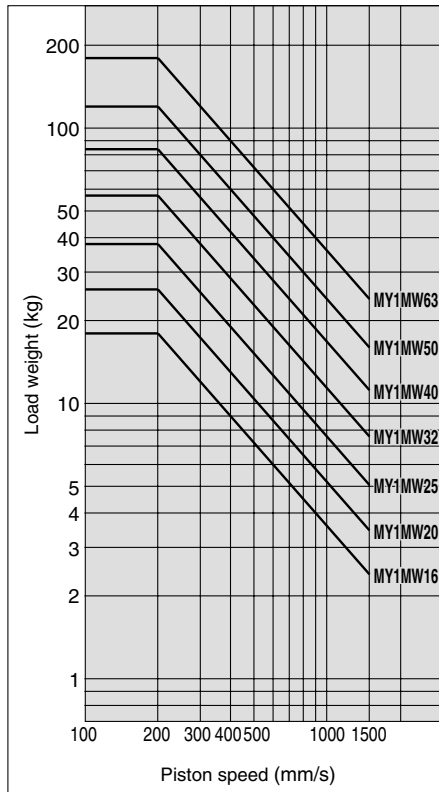

MY1MW/m₂

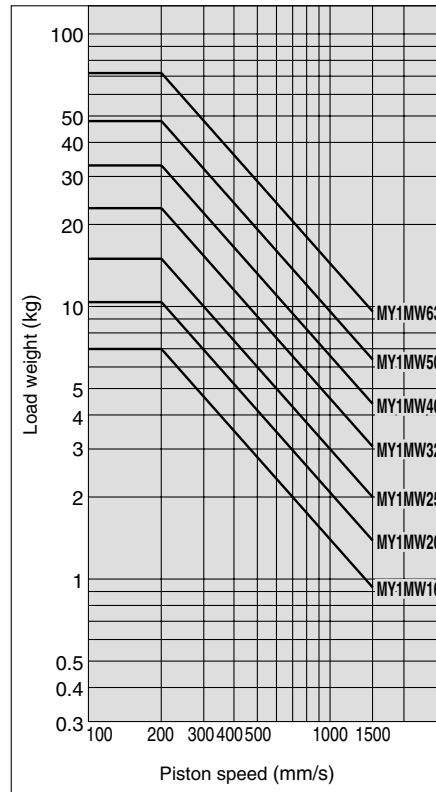

MY1MW/m₃

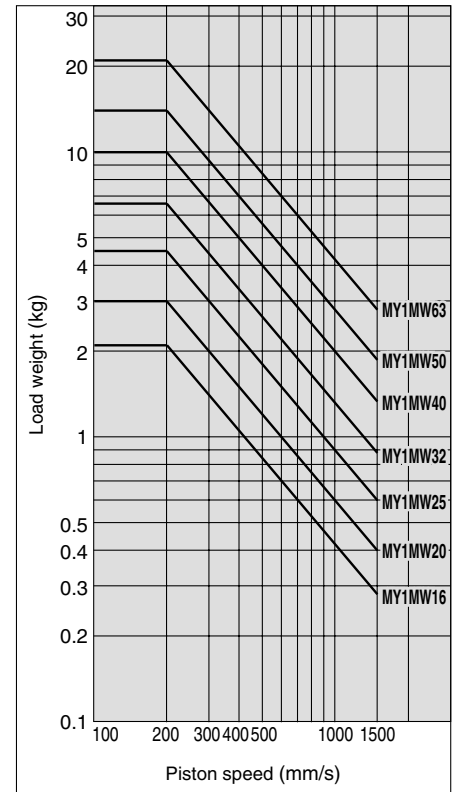

Maximum Allowable Moment/Maximum Load Weight

Maximum Allowable Moment: MY1CW

MY1CW/M₁

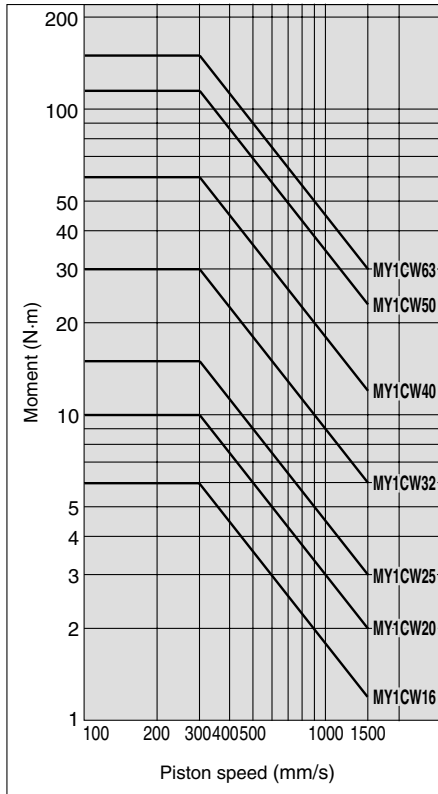

MY1CW/M₂

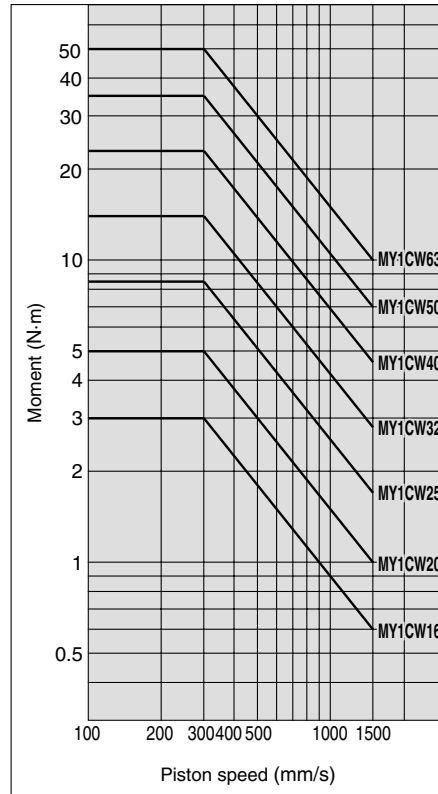

MY1CW/M₃

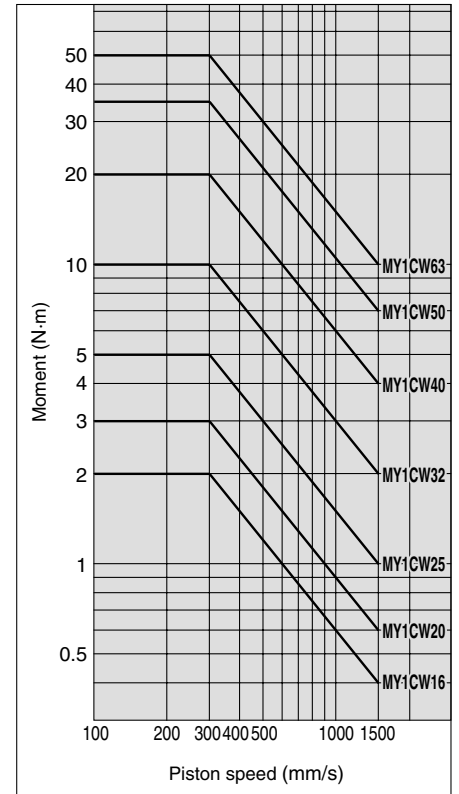

MX

MTS

MY

CY

MG

CX

D-

-X

20-

Data

Maximum Load Weight: MY1CW

MY1CW/m₁

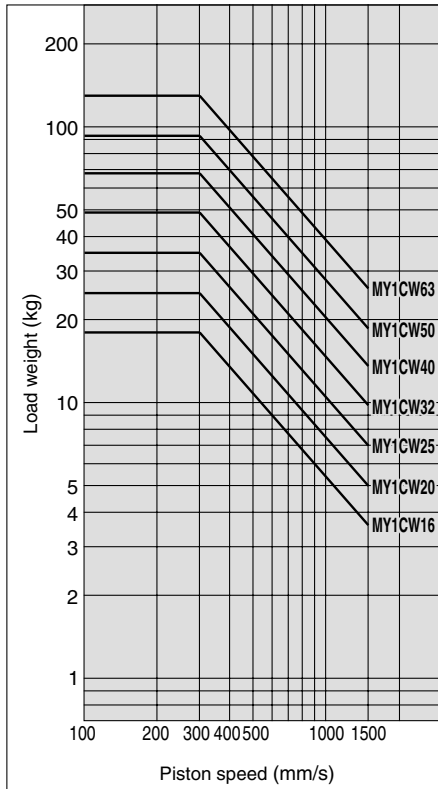

MY1CW/m₂

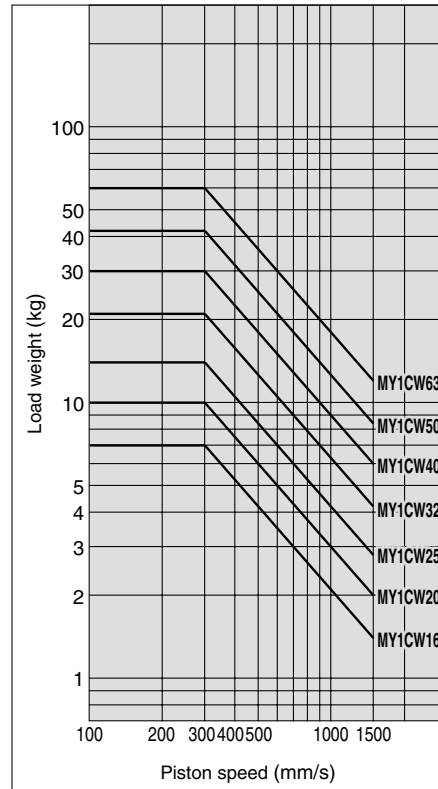

MY1CW/m₃

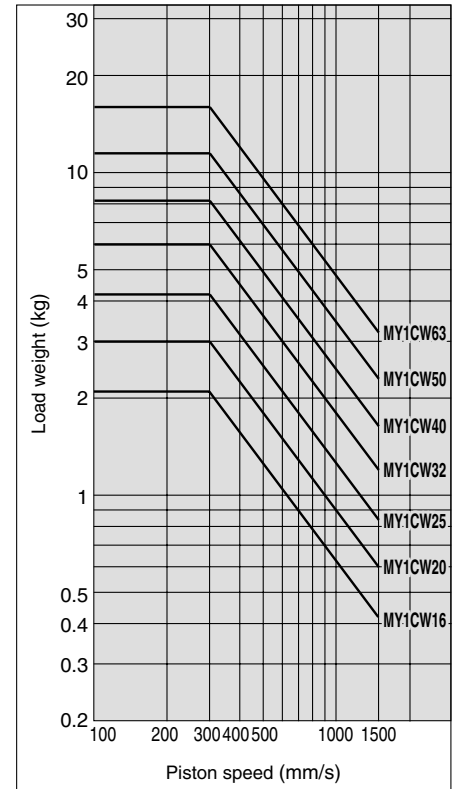

Cushion Capacity

Cushion Selection

<Air cushion>

Air cushions are a standard feature on mechanically jointed rodless cylinders.

The air cushion mechanism is incorporated to prevent excessive impact of the piston at the stroke end during high speed operation. The purpose of air cushion, thus, is not to decelerate the piston near the stroke end.

The ranges of load and speed that air cushions can absorb are within the air cushion limit lines shown in the graphs.

<Stroke adjusting unit with shock absorber>

Use this unit when operating with a load or speed exceeding the air cushion limit line, or when cushioning is required outside of the effective air cushion stroke range due to stroke adjustment.

L unit

Use this unit when the cylinder stroke is outside of the effective air cushion range even if the load and speed are within the air cushion limit line, or when the cylinder is operated in a load and speed range above the air cushion limit line or below the L unit limit line.

⚠ Caution

1. Refer to the figure below when using the adjusting bolt to perform stroke adjustment.

When the effective stroke of the shock absorber decreases as a result of stroke adjustment, the absorption capacity decreases dramatically. Secure the adjusting bolt at the position where it protrudes approximately 0.5 mm from the shock absorber.

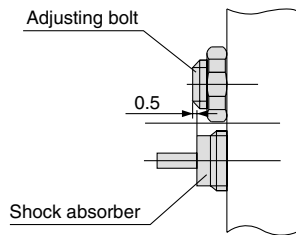

2. Do not use a shock absorber together with air cushion.

Air Cushion Stroke

Bore size (mm)	Cushion stroke
16	12
20	15
25	15
32	19
40	24
50	30
63	37

Absorption Capacity of Air Cushion and Stroke Adjusting Units

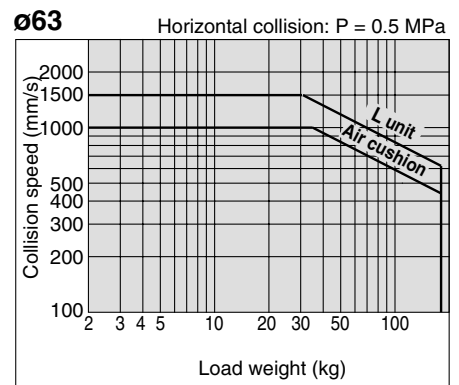
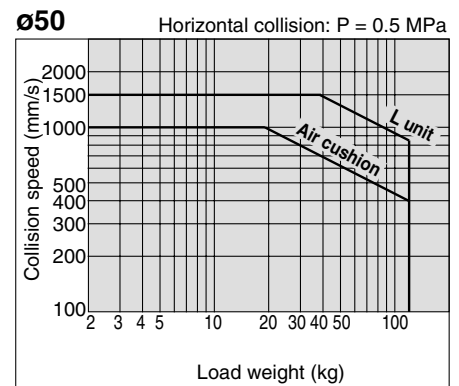
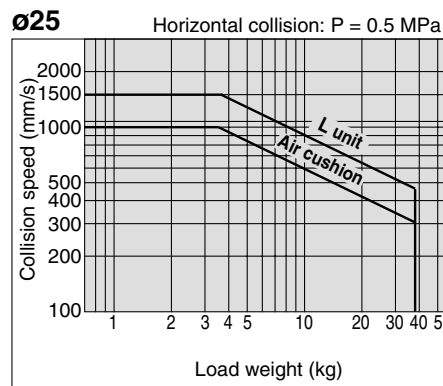
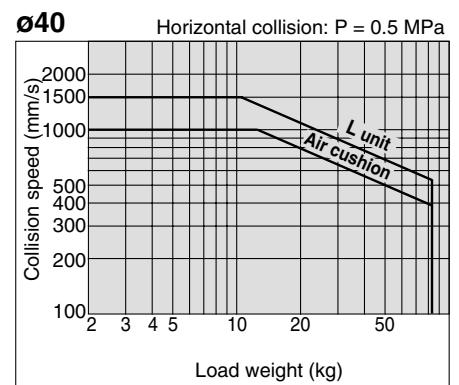
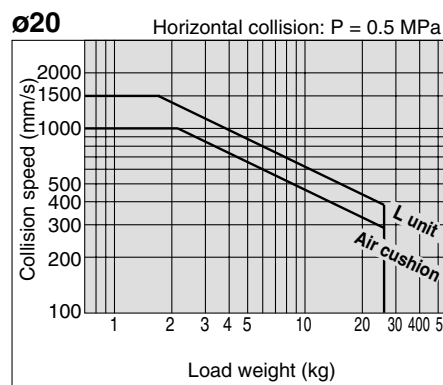
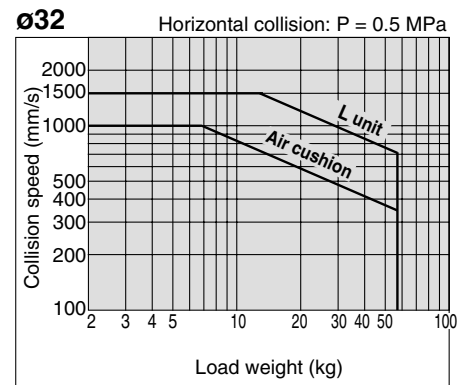
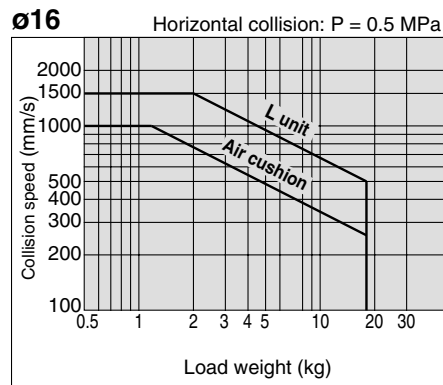

Cushion Capacity

Tightening Torque for Stroke Adjusting Unit Holding Bolts (N·m)

Bore size (mm)	Unit	Tightening torque
16	A	0.6
	L	
20	A	1.5
	L	
25	A	3.0
	L	
32	A	5.0
	L	
40	A	12
	L	
50	A	12
	L	
63	A	24
	L	

Tightening Torque for Stroke Adjusting Unit Lock Plate Holding Bolts (N·m)

Bore size (mm)	Unit	Tightening torque
25	L	1.2
32	L	3.3
40	L	3.3

Calculation of Absorbed Energy for Stroke Adjusting Unit with Shock Absorber (N·m)

Type of impact	Horizontal collision	Vertical (Downward)	Vertical (Upward)
Kinetic energy E ₁		$\frac{1}{2} m \cdot v^2$	
Thrust energy E ₂	Fs	Fs + m·g·s	Fs - m·g·s
Absorbed energy E		E ₁ + E ₂	

Symbol

- v: Speed of impact object (m/s)
- m: Weight of impact object (kg)
- F: Cylinder thrust (N)
- g: Gravitational acceleration (9.8 m/s²)
- s: Shock absorber stroke (m)

Note) The speed of the impact object is measured at the moment of impact with the shock absorber.

⚠ Precautions

Be sure to read before handling. For Safety Instructions and Actuator Precautions, refer to pages 8-34-3 to 8-34-6.

⚠ Caution

Use caution not to get your hands caught in the unit.

- When using a product with stroke adjusting unit, the space between the slide table (slider) and the stroke adjusting unit becomes narrow at the stroke end, causing a danger of hands getting caught. Install a protective cover to prevent direct contact with the human body.

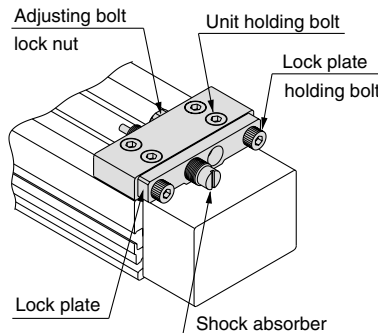

<Fastening of unit>

The unit can be secured by evenly tightening the four unit holding bolts.

⚠ Caution

Do not operate with the stroke adjusting unit fixed in an intermediate position.

When the stroke adjusting unit is fixed in an intermediate position, slippage can occur depending on the amount of energy released at the time of an impact. In such cases, the use of the adjusting bolt mounting brackets, available per made-to-order specifications -X416 and -X417, is recommended.

For other lengths, please consult with SMC (Refer to the "Tightening Torque for Stroke Adjusting Unit Holding Bolts" values in the chart at the upper left corner of this page.)

<Stroke adjustment with adjusting bolt>

Loosen the adjusting bolt lock nut, and adjust the stroke from the lock plate side using a hexagon wrench. Retighten the lock nut.

<Stroke adjustment with shock absorber>

Loosen the two lock plate holding bolts, turn the shock absorber and adjust the stroke. Then, uniformly tighten the lock plate holding bolts to secure the shock absorber.

Avoid excessive tightening of the holding bolts (except for ø16, ø20, ø50, and ø63). (Refer to "Tightening Torque for Stroke Adjusting Unit Lock Plate Holding Bolts" above left.)

Note)

Although the lock plate may slightly bend due to tightening of the lock plate holding bolt, this does not affect the shock absorber and locking function.

MX□

MTS

MY□

CY□

MG□

CX□

D-

-X

20-

Data

Model Selection 2

This section illustrates the standard model selection procedure using the actual operating conditions as one of the examples.

Calculation of Guide Load Factor

1. Operating Conditions

Cylinder **MY1MW40-500**

Average operating speed v_a **200 mm/s**

Mounting orientation **Horizontal mounting**

Wa: Connection plate $t = 10$ (880 g)

Wd: Workpiece (500 g)

Wc: MHL2-16D1(795 g)

MY1MW40-500

Wb: MGGLB25-200 (4.35 kg)

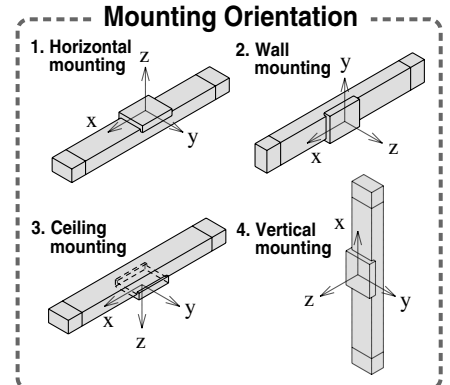
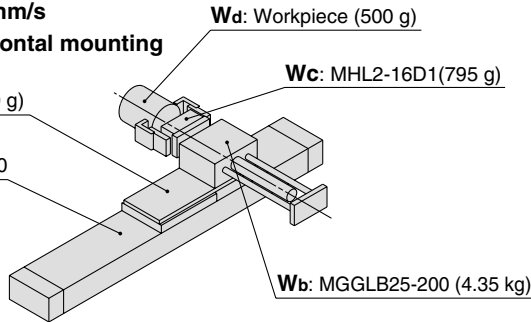

For actual examples of calculation for each orientation, refer to the pages above.

2. Load Blocking

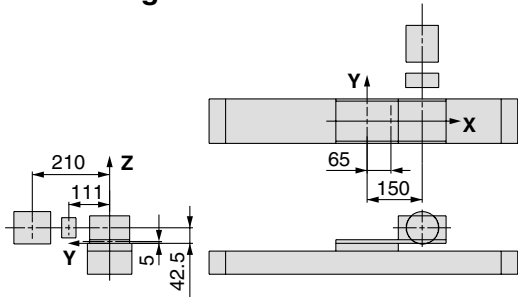

Weight and Center of Gravity for Each Workpiece

Workpiece no. W_n	Weight m_n	Center of gravity		
		X-axis X_n	Y-axis Y_n	Z-axis Z_n
Wa	0.88 kg	65 mm	0 mm	5 mm
Wb	4.35 kg	150 mm	0 mm	42.5 mm
Wc	0.795 kg	150 mm	111 mm	42.5 mm
Wd	0.5 kg	150 mm	210 mm	42.5 mm

$n = a, b, c, d$

3. Composite Center of Gravity Calculation

$$m_1 = \sum m_n$$

$$= 0.88 + 4.35 + 0.795 + 0.5 = \mathbf{6.525 \text{ kg}}$$

$$X = \frac{1}{m_1} \times \sum (m_n \times x_n)$$

$$= \frac{1}{6.525} (0.88 \times 65 + 4.35 \times 150 + 0.795 \times 150 + 0.5 \times 150) = \mathbf{138.5 \text{ mm}}$$

$$Y = \frac{1}{m_1} \times \sum (m_n \times y_n)$$

$$= \frac{1}{6.525} (0.88 \times 0 + 4.35 \times 0 + 0.795 \times 111 + 0.5 \times 210) = \mathbf{29.6 \text{ mm}}$$

$$Z = \frac{1}{m_1} \times \sum (m_n \times z_n)$$

$$= \frac{1}{6.525} (0.88 \times 5 + 4.35 \times 42.5 + 0.795 \times 42.5 + 0.5 \times 42.5) = \mathbf{37.4 \text{ mm}}$$

4. Calculation of Load Factor for Static Load

m_1 : Weight

$m_1 \text{ max}$ (from 1 of graph MY1MW/ m_1) = 84 (kg)

Load factor $\alpha_1 = m_1 / m_1 \text{ max} = 6.525 / 84 = \mathbf{0.08}$

M_1 : Moment

$M_1 \text{ max}$ (from (2) of graph MY1MW/ M_1) = 59 (N·m)

$M_1 = m_1 \times g \times X = 6.525 \times 9.8 \times 138.5 \times 10^{-3} = 8.86$ (N·m)

Load factor $\alpha_2 = M_1 / M_1 \text{ max} = 8.86 / 59 = \mathbf{0.15}$

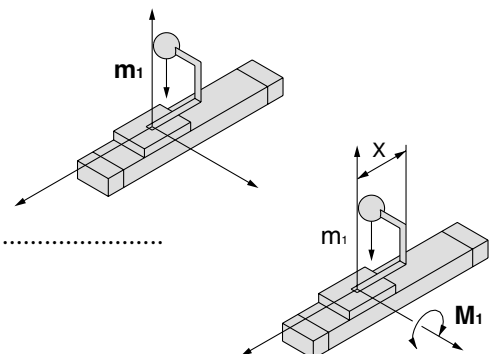

Calculation of Guide Load Factor

M₂: Moment

M_{2max} (from 3 of graph MY1MW: M_2) = 24 (N·m)

$M_3 = m_1 \times g \times Y = 6.525 \times 9.8 \times 29.6 \times 10^{-3} = 1.89$ (N·m)

Load factor $\alpha_3 = M_3/M_{2max} = 1.89/24 = \mathbf{0.08}$

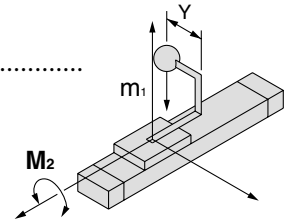

5. Calculation of Load Factor for Dynamic Moment

Equivalent load F_E at impact

$F_E = \frac{1.4}{100} \times 10a \times g \times m = \frac{1.4}{100} \times 200 \times 9.8 \times 6.525 = 179.1$ (N)

M_{1E}: Moment

M_{1Emax} (from 4 of graph MY1MW: M_1 where $1.410a = 280$ mm/s) = 42.1 (N·m)

$M_{1E} = \frac{1}{3} \times F_E \times Z = \frac{1}{3} \times 179.1 \times 37.4 \times 10^{-3} = 2.23$ (N·m)

Load factor $\alpha_4 = M_{1E}/M_{1Emax} = 2.23/42.1 = \mathbf{0.05}$

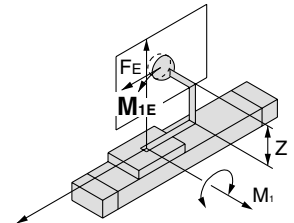

M_{3E}: Moment

M_{3Emax} (from 5 of graph MY1MW: M_3 where $1.410a = 280$ mm/s) = 5.7 (N·m)

$M_{3E} = \frac{1}{3} \times F_E \times Y = \frac{1}{3} \times 179.1 \times 29.6 \times 10^{-3} = 1.77$ (N·m)

Load factor $\alpha_5 = M_{3E}/M_{3Emax} = 1.77/5.7 = \mathbf{0.31}$

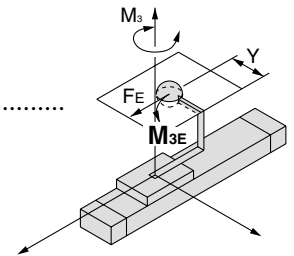

- MX
- MTS
- MY
- CY
- MG
- CX
- D-
- X
- 20-
- Data

6. Sum and Examination of Guide Load Factors

$\sum \alpha = \alpha_1 + \alpha_2 + \alpha_3 + \alpha_4 + \alpha_5 = \mathbf{0.67} \leq 1$

The above calculation is within the allowable value, and therefore the selected model can be used.

Select a shock absorber separately.

In an actual calculation, when the total sum of guide load factors $\sum \alpha$ in the formula above is more than 1, consider either decreasing the speed, increasing the bore size, or changing the product series. This calculation can be easily made using the "SMC Pneumatics CAD System".

Load Weight

MY1MW/m₁

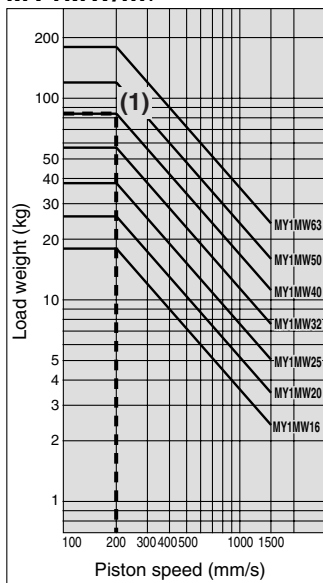

Allowable Moment

MY1MW/M₁

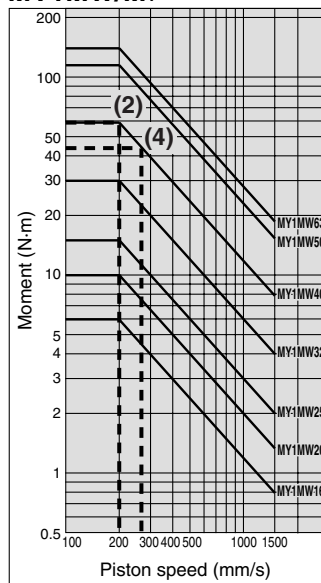

MY1MW/M₂

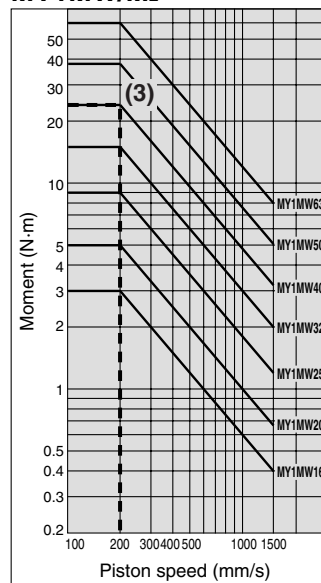

MY1MW/M₃

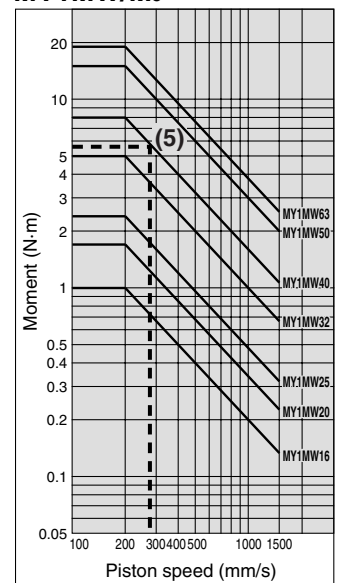

Mechanically Jointed Rodless Cylinder with Protective Cover Slide Bearing Guide Type/Cam Follower Guide Type

Series MY1□W

ø16, ø20, ø25, ø32, ø40, ø50, ø63

How to Order

MY1 **M** **W** **K** **25** **300** **Y7BW**

Guide type

M	Slide bearing type
C	Cam follower guide type

With protective cover

Side seal (Note)

Nil	None
K	With side seal

Note) Cylinders with side seal are available for ø16 to ø40.

Bore size (mm)

16	16 mm
20	20 mm
25	25 mm
32	32 mm
40	40 mm
50	50 mm
63	63 mm

Stroke

Refer to "Standard Stroke" on page 8-12-15.

Piping

Nil	Standard type
G	Centralized piping type

Auto switch type

Nil	Without auto switch
-----	---------------------

* For the applicable auto switch model, refer to the table below.

Number of auto switches

Nil	2 pcs
S	1 pcs
n	"n" pcs

Suffix for stroke adjusting unit (Note)

Nil	Both ends
S	One end

Note) "S" is available when stroke adjusting units are A and L.

Stroke adjusting unit

Nil	Without adjusting unit
A	With adjusting bolt
L	With low load shock absorber + Adjusting bolt
AL	With one A unit and one L unit

Shock Absorbers for L Unit

Unit no.	Bore size (mm)						
	16	20	25	32	40	50	63
L unit	RB0806	RB1007	RB1412			RB2015	

Applicable Auto Switch / Refer to page 8-30-1 for further information on auto switches.

For ø16, ø20

Type	Special function	Electrical entry	Indicator light	Wiring (Output)	Load voltage			Auto switch model		Lead wire length (m)*			Pre-wire connector	Applicable load	
					DC	AC		Perpendicular	In-line	0.5 (Nil)	3 (L)	5 (Z)			
Reed switch	—	Grommet	Yes	3-wire (NPN equivalent)	—	5 V	—	A96V	A96	●	●	—	—	IC circuit	—
				2-wire	24 V	12 V	100 V	A93V	A93	●	●	—	—	—	—
Solid state switch	—	Grommet	Yes	3-wire (NPN)	24 V	5 V, 12 V	—	M9NV	M9N	●	●	○	○	IC circuit	Relay PLC
				3-wire (PNP)				M9PV	M9P	●	●	○	○		
				2-wire				M9BV	M9B	●	●	○	○	—	
				3-wire (NPN)				F9NWV	F9NW	●	●	○	○	IC circuit	
				3-wire (PNP)				F9PWV	F9PW	●	●	○	○	—	
				2-wire				F9BWV	F9BW	●	●	○	○	—	
Solid state switch	Diagnostic indication (2-color indication)	Grommet	Yes	3-wire (NPN)	24 V	5 V, 12 V	—	Y69A	Y59A	●	●	○	○	IC circuit	Relay PLC
				3-wire (PNP)				Y7PV	Y7P	●	●	○	○		
				2-wire				Y69B	Y59B	●	●	○	○	—	
				3-wire (NPN)				Y7NWV	Y7NW	●	●	○	○	IC circuit	
				3-wire (PNP)				Y7PWV	Y7PW	●	●	○	○	—	
				2-wire				Y7BWV	Y7BW	●	●	○	○	—	
Solid state switch	Water resistant (2-color indication)	Grommet	Yes	2-wire	12 V	—	—	Y7BAL ⁽²⁾		●	●	○	○	—	—
				2-wire						●	●	○	○		

For ø25, ø32, ø40, ø50, ø63

Type	Special function	Electrical entry	Indicator light	Wiring (Output)	Load voltage			Auto switch model		Lead wire length (m)*			Pre-wire connector	Applicable load	
					DC	AC		Perpendicular (1)	In-line	0.5 (Nil)	3 (L)	5 (Z)			
Reed switch	—	Grommet	Yes	3-wire (NPN equivalent)	—	5 V	—	—	Z76	●	●	—	—	IC circuit	—
				2-wire	24 V	12 V	100 V	—	Z73	●	●	●	—	—	—
Solid state switch	—	Grommet	Yes	3-wire (NPN)	24 V	5 V, 12 V	—	Y69A	Y59A	●	●	○	○	IC circuit	Relay PLC
				3-wire (PNP)				Y7PV	Y7P	●	●	○	○		
				2-wire				Y69B	Y59B	●	●	○	○	—	
				3-wire (NPN)				Y7NWV	Y7NW	●	●	○	○	IC circuit	
				3-wire (PNP)				Y7PWV	Y7PW	●	●	○	○	—	
				2-wire				Y7BWV	Y7BW	●	●	○	○	—	
Solid state switch	Water resistant (2-color indication)	Grommet	Yes	2-wire	12 V	—	—	Y7BAL ⁽²⁾		●	●	○	○	—	—
				2-wire						●	●	○	○		

* Lead wire length symbols: 0.5 m.....Nil (Example) A93
3 m.....L (Example) Y59BL
5 m.....Z (Example) F9NWZ

* Solid state switches marked with "○" are produced upon receipt of order.
Note 1) Perpendicular electrical entry is not available for ø50 and ø63.
Note 2) Water resistant switches are not available for ø50 and ø63.

Refer to page 8-12-24 for details on other applicable auto switches than listed above.

• For details about auto switches with pre-wire connector, refer to page 8-30-52.

Mechanically Jointed Rodless Cylinder With Protective Cover Series MY1□W

Specifications

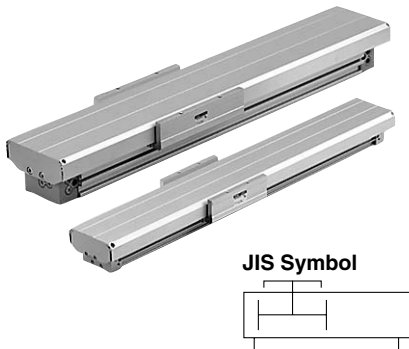

Bore size (mm)		16	20	25	32	40	50	63
Fluid	Air							
Action	Double acting							
Operating pressure range	MY1MW: 0.15 to 0.8 MPa; MY1CW: 0.1 to 0.8 MPa							
Proof pressure	1.2 MPa							
Ambient and fluid temperature	5 to 60°C							
Cushion	Air cushion							
Lubrication	Non-lube							
Stroke length tolerance	1000 or less ^{+1.8} ₀ 1001 to 3000 ^{+2.8} ₀		2700 or less ^{+1.8} ₀ ; 2701 to 5000 ^{+2.8} ₀					
Piping port size	Front/Side port	M5 x 0.8			Rc 1/8	Rc 1/4	Rc 3/8	
	Bottom port (Centralized piping type only)	ø4			ø5	ø6	ø8	ø10

Stroke Adjusting Unit Specifications

Bore size (mm)	16		20		25		32		40		50		63	
	A	L	A	L	A	L	A	L	A	L	A	L	A	L
Configuration	With adjusting bolt	RB 0806 with adjusting bolt	With adjusting bolt	RB 0806 with adjusting bolt	With adjusting bolt	RB 1007 with adjusting bolt	With adjusting bolt	RB 1412 with adjusting bolt	With adjusting bolt	RB 1412 with adjusting bolt	With adjusting bolt	RB 2015 with adjusting bolt	With adjusting bolt	RB 2015 with adjusting bolt
Shock absorber model														
Fine stroke adjustment range (mm)	0 to -5.6		0 to -6		0 to -11.5		0 to -12		0 to -16		0 to -20		0 to -25	
Stroke adjustment range	When exceeding the stroke fine adjustment range: Utilize a made-to-order specifications "-X416" and "-X417".													

Shock Absorber Specifications

Model	RB 0806	RB 1007	RB 1412	RB 2015	
	Max. energy absorption (J)	2.9	5.9	19.6	58.8
Stroke absorption (mm)	6	7	12	15	
Max. collision speed (mm/s)	1500				
Max. operating frequency (cycle/min)	80	70	45	25	
Spring force (N)	Extended	1.96	4.22	6.86	8.34
	Retracted	4.22	6.86	15.98	20.50
Operating temperature range (°C)	5 to 60				

Piston Speed

Bore size (mm)		16 to 63
Without stroke adjusting unit		100 to 1000 mm/s
Stroke adjusting unit	A unit	100 to 1000 mm/s ⁽¹⁾
	L unit	100 to 1500 mm/s ⁽²⁾

Note 1) The air cushion capacity will be reduced when the stroke adjustment range is increased by the adjusting bolt. When exceeding the air cushion stroke ranges on page 8-12-10, the piston speed should be 100 to 200 mm per second.

Note 2) The piston speed is 100 to 1000 mm/s for centralized piping.

Note 3) Use at a speed within the absorption capacity range. Refer to page 8-12-10.

Made to Order Specifications (For details, refer to page 8-31-1.)

Symbol	Specifications
-XB11	Long stroke
-XC67	NBR rubber lining in dust seal band
-X416	Holder mounting bracket I
-X417	Holder mounting bracket II

Standard Stroke

Bore size (mm)	Standard stroke (mm)*	Maximum manufacturable stroke (mm)
16	100, 200, 300, 400, 500, 600, 700, 800, 900, 1000, 1200, 1400, 1600, 1800, 2000	3000
20, 25, 32, 40, 50, 63		

* Strokes are manufacturable in 1 mm increments, up to the maximum stroke. However, when exceeding a 2000 mm stroke, specify "-XB11" at the end of the model number. For details, refer to the "Made to Order Specifications" on page 8-31-1.

Series MY1□W

Theoretical Output

Bore size (mm)	Piston area (mm ²)	Operating pressure (MPa)						
		0.2	0.3	0.4	0.5	0.6	0.7	0.8
16	200	40	60	80	100	120	140	160
20	314	62	94	125	157	188	219	251
25	490	98	147	196	245	294	343	392
32	804	161	241	322	402	483	563	643
40	1256	251	377	502	628	754	879	1005
50	1962	392	588	784	981	1177	1373	1569
63	3115	623	934	1246	1557	1869	2180	2492

(N)

Weight

Bore size (mm)	MY1MW		MY1CW		Side support weight (per set)	Stroke adjusting unit weight (per unit)	
	Basic weight	Additional weight per each 50mm of stroke	Basic weight	Additional weight per each 50mm of stroke	Type A and B	A unit weight	L unit weight
16	1.25	0.16	1.25	0.16	0.01	0.03	0.04
20	1.90	0.19	1.85	0.18	0.02	0.04	0.05
25	2.56	0.28	2.50	0.28	0.02	0.07	0.11
32	4.75	0.43	4.62	0.42	0.04	0.14	0.23
40	7.79	0.61	7.51	0.57	0.08	0.25	0.34
50	13.53	0.83	13.61	0.82	0.08	0.36	0.51
63	21.84	1.18	21.94	1.17	0.17	0.68	0.83

(kg)

Calculation: (Example) MY1MW25-300A

- Basic weight 2.56 kg
- Additional weight 0.28 kg per 50 st
- Weight of A unit 0.07 kg
- Cylinder stroke.....300 st
- $2.56 + 0.28 \times 300 \div 50 + 0.07 \times 2 \cong 4.38$ kg

Option

Stroke Adjusting Unit Part No.

Bore size (mm) Unit no.	16	20	25	32	40	50	63
A unit	MYM-A16A	MYM-A20A	MYM-A25A	MYM-A32A	MYM-A40A	MYM-A50A	MYM-A63A
L unit	MYM-A16L	MYM-A20L	MYM-A25L	MYM-A32L	MYM-A40L	MYM-A50L	MYM-A63L

Side Support Part No.

Bore size (mm) Type	16	20	25	32	40	50	63
Side support A	MY-S16A	MY-S20A	MY-S25A	MY-S32A	MY-S40A		MY-S63A
Side support B	MY-S16B	MY-S20B	MY-S25B	MY-S32B	MY-S40B		MY-S63B

For detailed dimensions, refer to page 8-12-22.

Construction

MY1□W

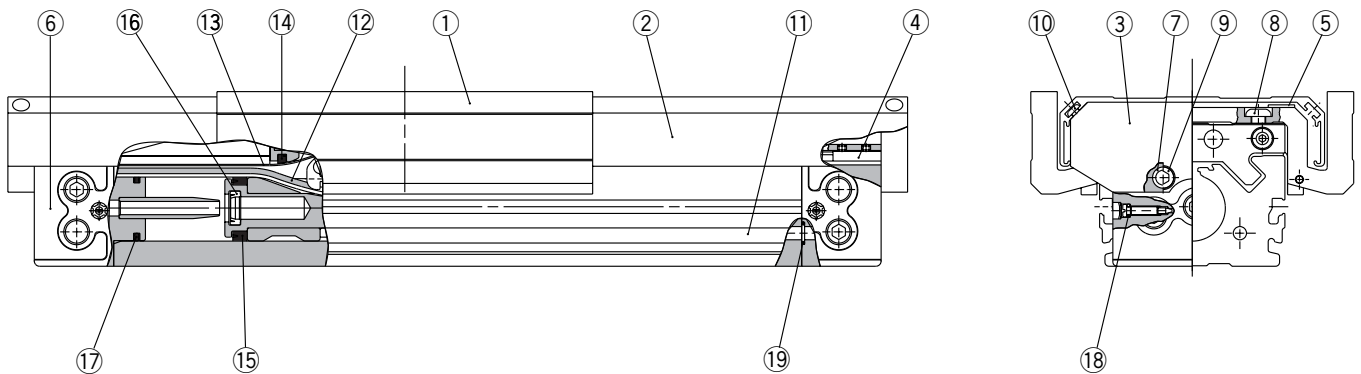

MY1□WK with side seal

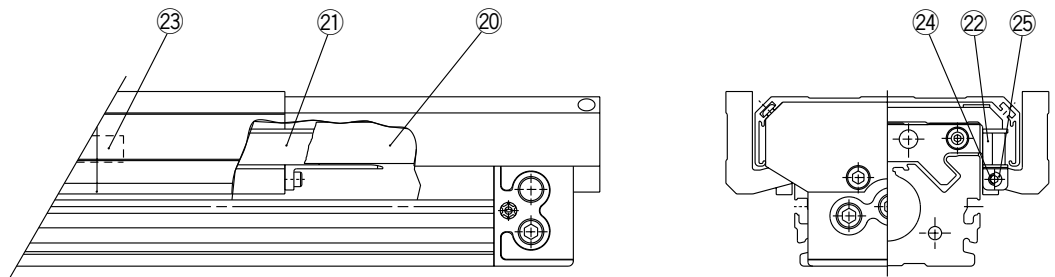

MX□

MTS

MY□

CY□

MG□

CX□

D-

-X

20-

Data

Component Parts

No.	Description	Material	Note	ø16	ø20	ø25	ø32	ø40	ø50	ø63
①	Slide table	Aluminum alloy	Hard anodized							
②	Cover	Aluminum alloy	Hard anodized							
③	End plate	Aluminum alloy	Hard anodized							
④	Belt clamp	Special resin								
⑤	Slide plate	Special resin								
⑥	Port cover	Special resin	(ø25 to ø40)							
⑦	Spacer	Stainless steel	(ø25 to ø40)							
⑧	Hexagon socket button head screw	Chromium molybdenum steel	Nickel plated							
⑨	Hexagon socket head cap screw	Chromium molybdenum steel	Nickel plated							
⑩	Hexagon socket button head screw	Chromium molybdenum steel	Nickel plated							
⑪	Rodless cylinder	—	MY1M/MY1C							
⑫	Seal guide A	Special resin								
⑬	Seal guide B	Special resin								
⑭	Slide plate	Special resin								
⑮	Spacer	Stainless steel								
⑯	Hexagon socket head cap screw	Chromium molybdenum steel	Nickel plated							

Seal List

No.	Description	Material	Qty.	ø16	ø20	ø25	ø32	ø40	ø50	ø63
⑫	Seal belt	Special resin	1	MY16-16A-Stroke	MY20-16A-Stroke	MY25-16A-Stroke	MY32-16A-Stroke	MY40-16A-Stroke	MY50-16A-Stroke	MY63-16A-Stroke
⑬	Dust seal band	Stainless steel	1	MY16-16B-Stroke	MY20-16B-Stroke	MY25-16B-Stroke	MY32-16B-Stroke	MY40-16B-Stroke	MY50-16B-Stroke	MY63-16B-Stroke
⑭	Scraper	NBR	2	MYM16-15AK0500	MYM20-15AK0501	MYM25-15AA5903	MYM32-15AA5904	MYM40-15AA5905	MYM50-15AK0502	MYM63-15AK0503
⑮	Piston seal	NBR	2	GMY16	GMY20	GMY25	GMY32	GMY40	GMY50	GMY63
⑯	Cushion seal	NBR	2	MYB16-15-A7163	MYB20-15-A7164	RCS-8	RCS-10	RCS-12	MC-16	MC-20
⑰	Tube gasket	NBR	2	P12	P16	TMY-25	TMY-32	TMY-40	P44	P53
⑱	O-ring	NBR	2	ø4 x ø1.8 x ø1.1	ø5.1 x ø3 x ø1.05	ø7.15 x ø3.75 x ø1.7	ø8.3 x ø4.5 x ø1.9	C-4	C-4	C-4
⑲	O-ring	NBR	4	ø7 x ø4 x ø1.5	ø7 x ø4 x ø1.5	C-6	C-7	C-9	C-11.2	C-14
⑳	Side seal assembly	Polyurethane	2	MYMK-16-Stroke	MYMK-20-Stroke	MYMK-25-Stroke	MYMK-32-Stroke	MYMK-40-Stroke	—	—

Note) Two types of dust seal bands are available. Verify the type to use, since the part number varies depending on the treatment of the hexagon socket head set screw.

A Black zinc chromated → MY□□-16B-Stroke B Nickel plated → MY□□-16BW-Stroke

Series MY1□W

Dimensions: $\phi 16, \phi 20$

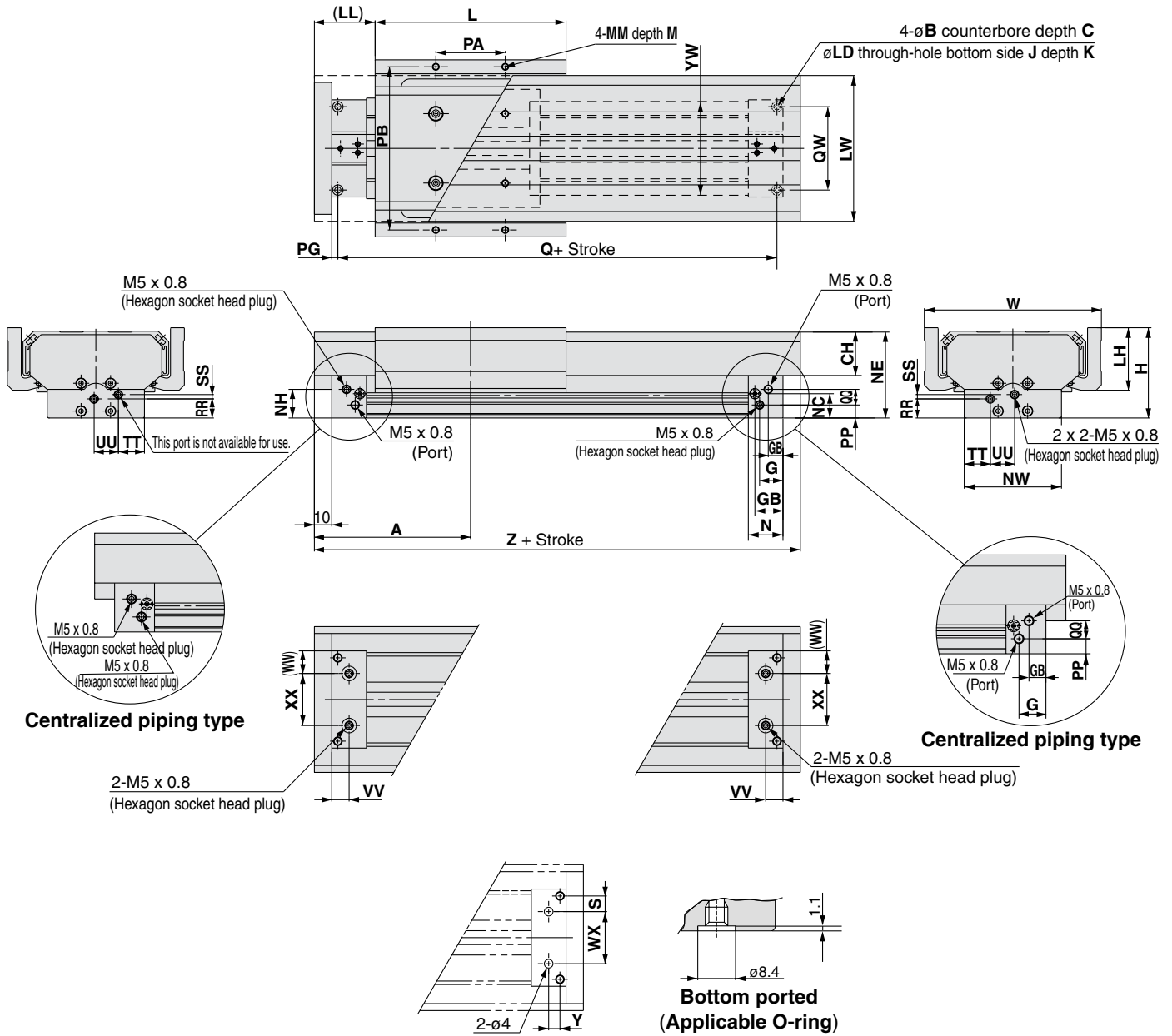

Bore size (mm)	A	B	C	CH	G	GA	GB	H	J	K	L	LD	LH	LL	LW	M	MM	N	NC	NE	NH	NW
16	90	6.0	3.5	25	13.5	8.5	16.2	52	M5 x 0.8	10	110	3.6	38	35	84	6.0	M4 x 0.7	20	14	49.5	16.5	56
20	110	7.5	4.5	26	12.5	—	20.0	58	M6 x 1	12	130	4.8	39	45	88	7.5	M5 x 0.8	25	17	55.5	21.7	60
Bore size (mm)	PA	PB	PG	PP	Q	QQ	QW	RR	SS	TT	UU	VV	W	WW	YW	Z						
16	40	94	3.5	7.5	153	9	48	11.0	2.5	15	14	10.0	102	13	54	180						
20	50	100	4.5	11.5	191	10	45	14.5	5.0	18	12	12.5	110	14	58	220						

Hole Size for Centralized Piping on the Bottom

(Mounting side should be machined to these dimensions.)

Bore size (mm)	S	WX	Y	Applicable O-ring
16	9	30	6.5	C6
20	6.5	32	8	C6

Mechanically Jointed Rodless Cylinder With Protective Cover Series MY1□W

Dimensions: $\phi 25$, $\phi 32$, $\phi 40$

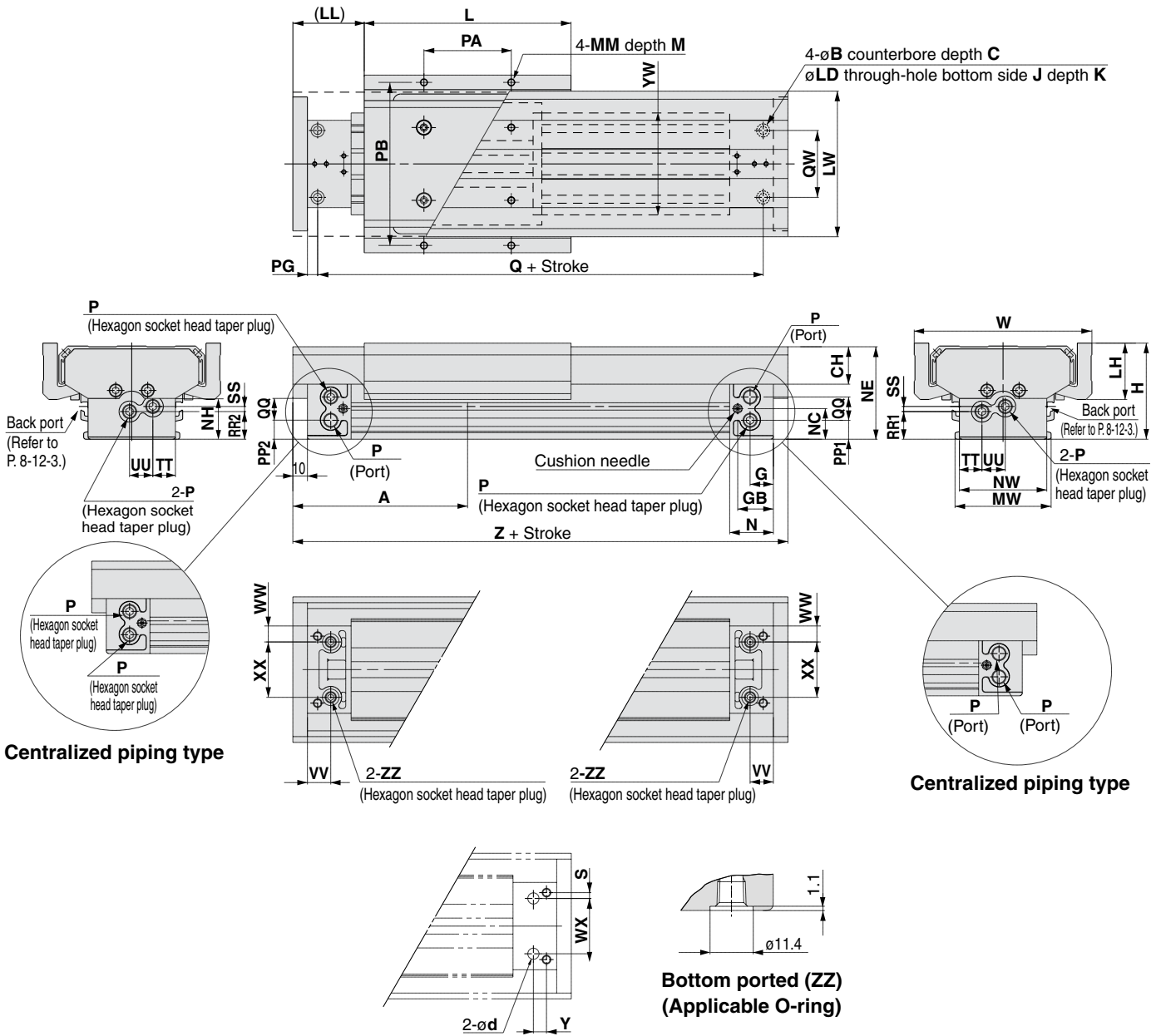

- MX□
- MTS
- MY□
- CY□
- MG□
- CX□
- D-
- X
- 20-
- Data

Bore size (mm)	A	B	C	CH	G	GB	H	J	K	L	LD	LH	LL	LW	M	MM	MW	N	NC	NE	NH	NW
25	120	9	5.5	25.7	17	24.5	66	M6 x 1	9.5	142	5.6	38.7	49	100	10	M5 x 0.8	66	30	21	64	28	60
32	150	11	6.5	31.5	19	30.0	82	M8 x 1.25	16.0	172	6.8	44.2	64	122	13	M6 x 1	80	37	26	80	37	74
40	180	14	8.5	34.8	23	36.5	98	M10 x 1.5	15.0	202	8.6	47.2	79	138	13	M6 x 1	96	45	32	96	48	94

Bore size (mm)	PA	PB	PG	PP1	PP2	Q	QQ	QW	RR1	RR2	SS	TT	UU	VV	W	WW	YW	Z
25	60	112	7	12.7	12.7	206	16	46	18.9	17.9	5.1	15.5	16	16	122	11	70	240
32	80	134	8	15.5	18.5	264	16	60	22.0	24.0	4.0	21.0	16	19	144	13	88	300
40	100	150	9	17.5	20.0	322	26	72	25.5	29.0	9.0	26.0	21	23	160	20	104	360

Hole Size for Centralized Piping on the Bottom

(Mounting side should be machined to these dimensions.)

Bore size (mm)	D	d	WX	Y	S	Applicable O-ring
25	11.4	6	38	9	4	C9
32	11.4	6	48	11	6	C9
40	13.4	8	54	14	9	C11.2

Series MY1□W

Dimensions: $\varnothing 50, \varnothing 63$

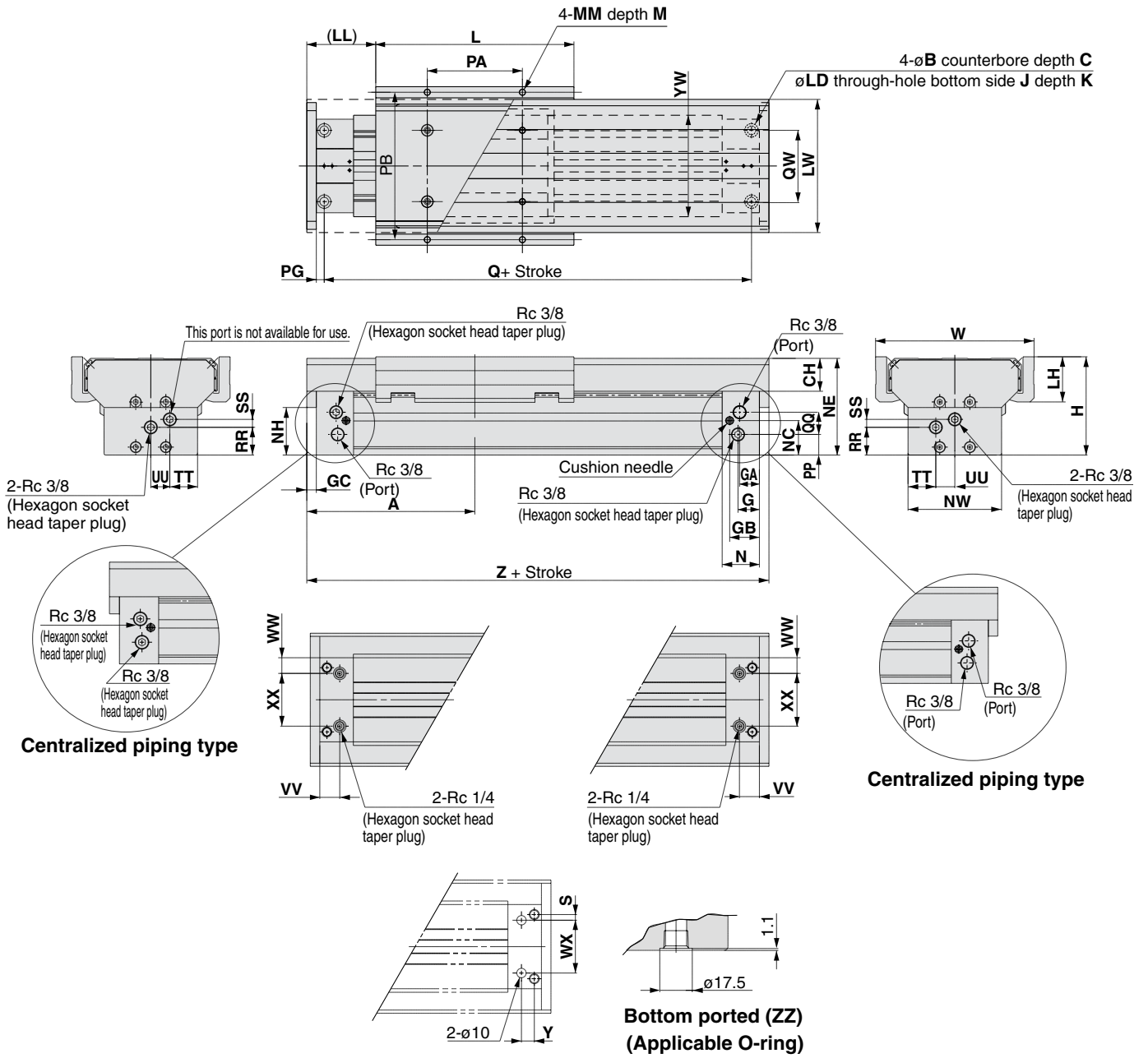

Bore size (mm)	A	B	C	CH	G	GA	GB	GC	H	J	K	L	LD	LH	LL	LW	M	MM	N	NC	NE	NH
50	212	17	10.5	41.5	27.0	25.0	37.5	12	124	M14 x 2	28	250	11	57	87	168	15	M8 x 1.25	47	44	122	60
63	245	19	12.5	47.0	29.5	27.5	39.5	15	149	M16 x 2	32	290	14	65	100	200	16	M10 x 1.25	50	60	147	70
Bore size (mm)	NW	PA	PB	PG	PP	Q	QQ	QW	RR	SS	TT	UU	VV	W	WW	YW	Z					
50	118	120	186	10	26	380	28	90	35	10	35	24	28	200	22	128	424					
63	142	140	220	12	42	436	30	110	49	13	43	28	30	236	25	152	490					

Hole Size for Centralized Piping on the Bottom

(Mounting side should be machined to these dimensions.)

Bore size (mm)	S	WX	Y	Applicable O-ring
50	8	74	18	C15
63	9	92	18	C15

Stroke Adjusting Unit

With adjusting bolt

MY1□W Bore size — Stroke **A**

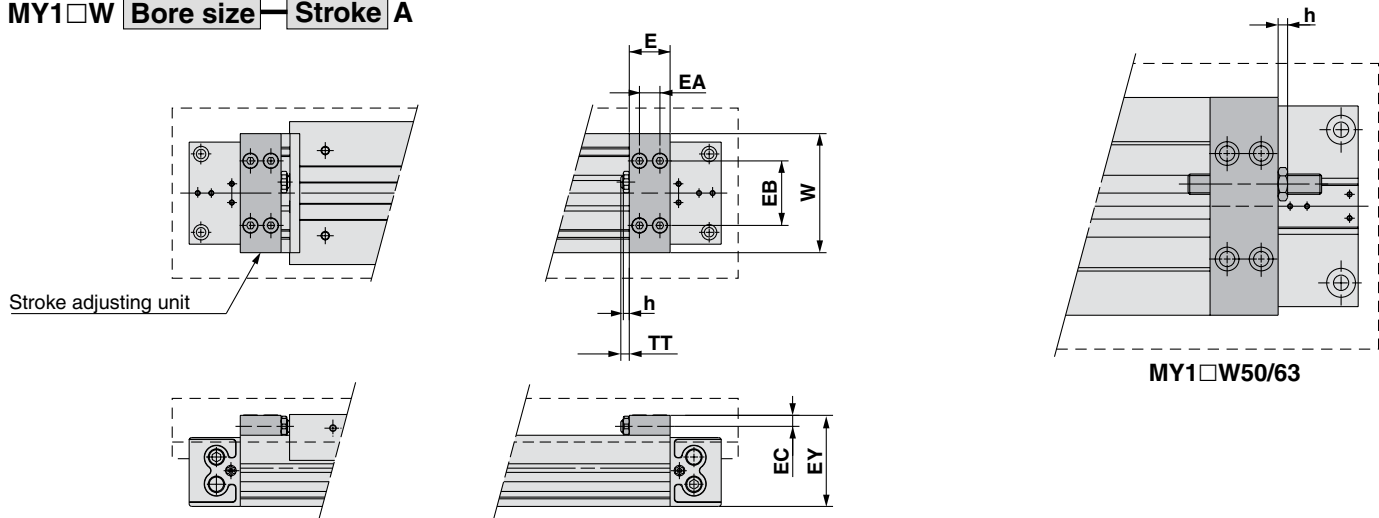

Model	E	EA	EB	EC	EY	FC	h	TT	W
MY1□W16	14.6	7	30	5.8	39.5	14	3.6	5.4 (Max. 11)	58
MY1□W20	20	10	32	5.8	45.5	14	3.6	5 (Max. 11)	58
MY1□W25	24	12	38	6.5	53.5	13	3.5	5 (Max. 16.5)	70
MY1□W32	29	14	50	8.5	67	17	4.5	8 (Max. 20)	88
MY1□W40	35	17	57	10	83	17	4.5	9 (Max. 25)	104
MY1□W50	40	20	66	14	106	26	5.5	13 (Max. 33)	128
MY1□W63	52	26	77	14	129	31	5.5	13 (Max. 38)	152

With low load shock absorber + Adjusting bolt

MY1□W Bore size — Stroke **L**

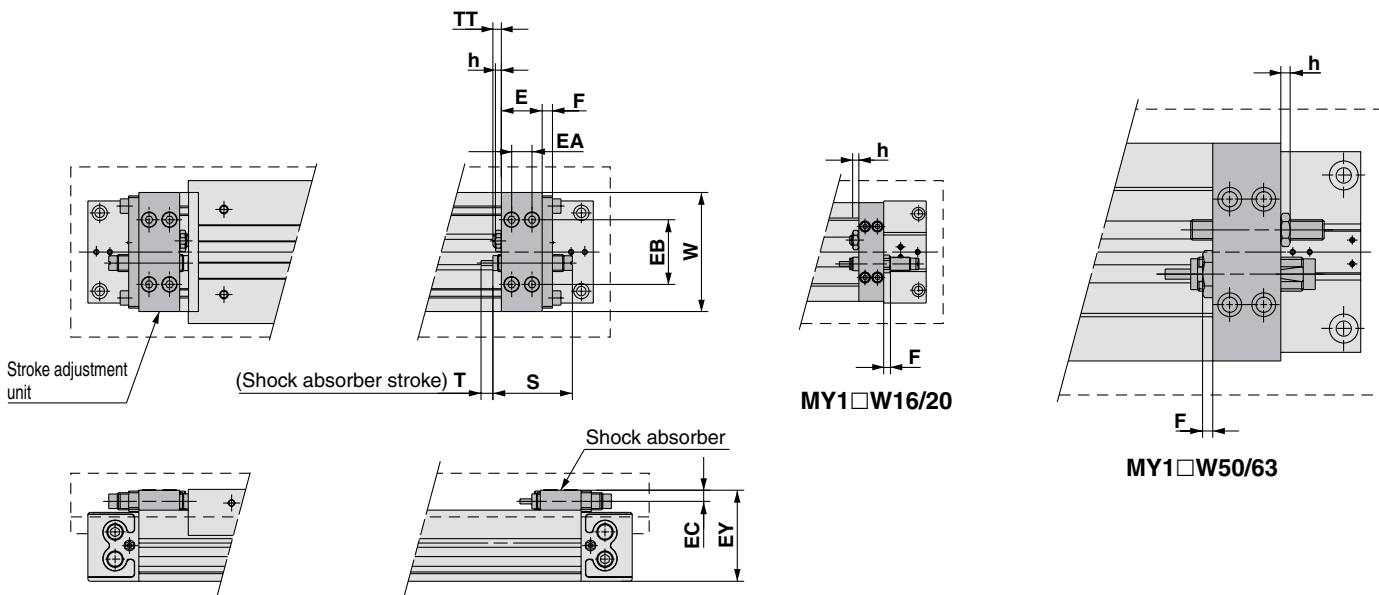

Model	E	EA	EB	EC	EY	F	FB	FC	FH	FW	h	S	T	TT	W	Shock absorber model
MY1□W16	14.6	7	30	5.8	39.5	4	—	14	—	—	3.6	40.8	6	5.4 (Max. 11)	58	RB0806
MY1□W20	20	10	32	5.8	45.5	4	—	14	—	—	3.6	40.8	6	5 (Max. 11)	58	RB0806
MY1□W25	24	12	38	6.5	53.5	6	54	13	13	66	3.5	46.7	7	5 (Max. 16.5)	70	RB1007
MY1□W32	29	14	50	8.5	67	6	67	17	16	80	4.5	67.3	12	8 (Max. 20)	88	RB1412
MY1□W40	35	17	57	10	83	6	78	17	17.5	91	4.5	67.3	12	9 (Max. 25)	104	RB1412
MY1□W50	40	20	66	14	106	6	—	26	—	—	5.5	73.2	15	13 (Max. 33)	128	RB2015
MY1□W63	52	26	77	14	129	6	—	31	—	—	5.5	73.2	15	13 (Max. 38)	152	RB2015

- MX□
- MTS
- MY□**
- CY□
- MG□
- CX□
- D-
- X
- 20-
- Data

Series MY1□W

Side Support

Side support A MY-S□A

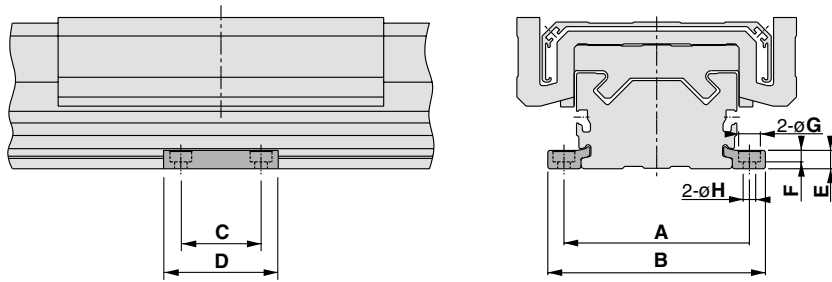

Side support B MY-S□B

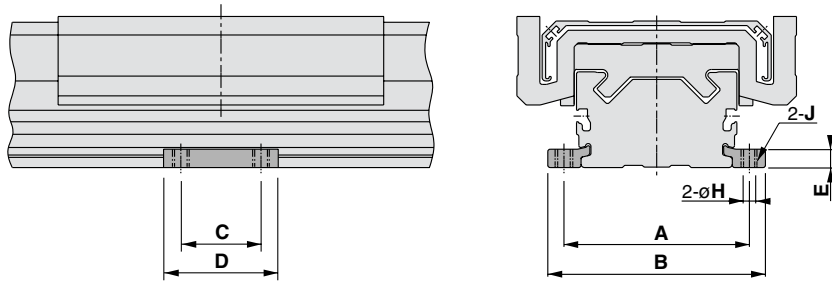

(mm)

Model	Applicable bore size	A	B	C	D	E	F	G	H	J
MY-S16 [△]	MY1□W16	61	71.6	15	26	4.9	3	6.5	3.4	M4 x 0.7
MY-S20 [△]	MY1□W20	67	79.6	25	38	6.4	4	8	4.5	M5 x 0.8
MY-S25 [△]	MY1□W25	81	95	35	50	8	5	9.5	5.5	M6 x 1
MY-S32 [△]	MY1□W32	100	118	45	64	11.7	6	11	6.6	M8 x 1.25
MY-S40 [△]	MY1□W40	120	142	55	80	14.8	8.5	14	9	M10 x 1.5
	MY1□W50	142	164							
MY-S63 [△]	MY1□W63	172	202	70	100	18.3	10.5	17.5	11.5	M12 x 1.75

Guide for Side Support Application

For long stroke operation, the cylinder tube may be deflected depending on its own weight and the load weight. In such a case, use a side support in the middle section. The spacing (ℓ) of the support must be no more than the values shown in the graph on the right.

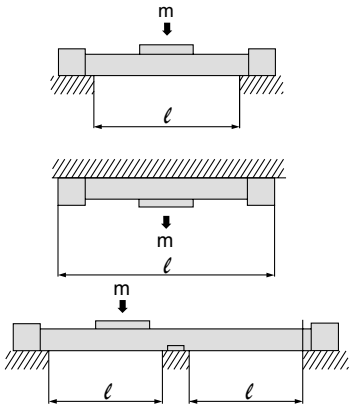

⚠ Caution

1. If the cylinder mounting surfaces are not measured accurately, using a side support may cause poor operation. Therefore, be sure to level the cylinder tube when mounting. Also, for long stroke operation involving vibration and impact, use of a side support is recommended even if the spacing value is within the allowable limits shown in the graph.
2. Support brackets are not for mounting; use them solely for providing support.

MY1MW

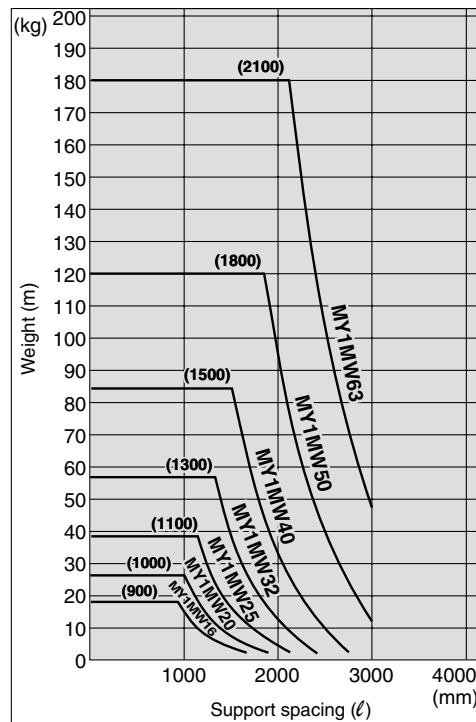

MY1CW

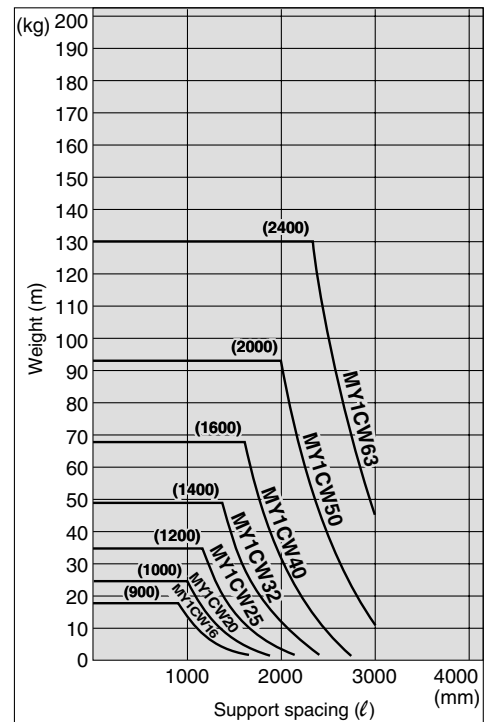

Proper Auto Switch Mounting Position (Detection at stroke end)

Note) The operating range is a guide including hysteresis, but is not guaranteed.
There may be varied substantially depending on the surrounding environment (Assuming approximately 30% dispersion).

MY1CW16/20
MY1MW16/20

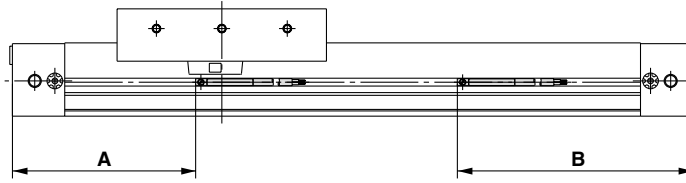

Reed Switch

D-A90(V), D-A93(V), D-A96(V) (mm)

Mounting position	ø16	ø20
A	70	90
B	90	110
Operating range ^{Note)}	11	7.5

Solid State Switch

D-M9N(V), D-M9P(V), D-M9B(V)

Mounting position	ø16	ø20
A	74	94
B	86	106
Operating range ^{Note)}	6.5	7

D-F9NW(V), D-F9PW(V), D-F9BW(V)

Mounting position	ø16	ø20
A	73	93
B	87	107
Operating range ^{Note)}	8.5	6.5

MY1MW25/32/40/50/63

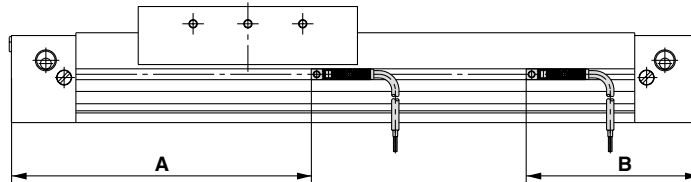

Reed Switch

D-Z73, D-Z76, D-Z80 (mm)

Mounting position	ø25	ø32	ø40	ø50	ø63
A	139.5	184.5	229.5	278.5	323.5
B	80.5	95.5	110.5	121.5	136.5
Operating range ^{Note)}	12	12	12	11.5	11.5

Solid State Switch

D-Y59^A_B, D-Y69^A_B, D-Y7P(V)
D-Y7NW(V), D-Y7PW(V), D-Y7BW(V)

Mounting position	ø25	ø32	ø40	ø50	ø63
A	139.5	184.5	229.5	278.5	323.5
B	180.5	95.5	110.5	121.5	136.5
Operating range ^{Note)}	5	5	5	5.5	5.5

D-Y7BAL (mm)

Mounting position	ø25	ø32	ø40
A	139.5	184.5	229.5
B	180.5	95.5	110.5
Operating range ^{Note)}	8	8	8

⦿ Perpendicular electrical entry is not available for ø50 and ø63.
(D-Y69A, D-Y69B, D-Y7PV
D-Y7NWV, D-Y7PWV, D-Y7BWV)

MY1CW25/32/40/50/63

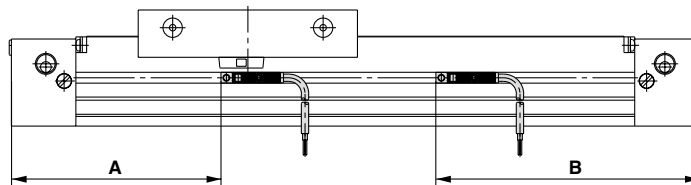

Reed Switch

D-Z73, D-Z76, D-Z80 (mm)

Mounting position	ø25	ø32	ø40	ø50	ø63
A	97.5	127.5	157.5	278.5	323.5
B	122.5	152.5	182.5	121.5	136.5
Operating range ^{Note)}	12	12	12	11.5	11.5

Solid State Switch

D-Y59^A_B, D-Y69^A_B, D-Y7P(V)
D-Y7NW(V), D-Y7PW(V), D-Y7BW(V)

Mounting position	ø25	ø32	ø40	ø50	ø63
A	97.5	127.5	157.5	278.5	323.5
B	122.5	152.5	182.5	121.5	136.5
Operating range ^{Note)}	5	5	5	5.5	5.5

D-Y7BAL (mm)

Mounting position	ø25	ø32	ø40
A	97.5	127.5	157.5
B	122.5	152.5	182.5
Operating range ^{Note)}	8	8	8

⦿ Perpendicular electrical entry is not available for ø50 and ø63.
(D-Y69A, D-Y69B, D-Y7PV
D-Y7NWV, D-Y7PWV, D-Y7BWV)

Mounting of Auto Switch & Installation of Lead Wire Cover (ø50, ø63)

Caution

Be sure to install a lead wire cover on the auto switches for size ø50 and ø63 cylinders.

Install a lead wire cover following the procedures provided below to prevent the lead wire from interfering with the slider.

Lead wire cover is packaged together with size ø50 and ø63 cylinders equipped with auto switches.

For ordering the lead wire cover separately, use the following part number:

MYM63GAR6386-1640 (Length: 2 m)

1. Auto switch mounting position

Up to 4 auto switches can be mounted on one side of the cylinder (total of 8 switches on both sides).

When multiple auto switches are used, be sure to use the lead wire groove and pull the lead wires out from the edge of the cylinder. (Bold lines in Fig. (1) indicate lead wires.)

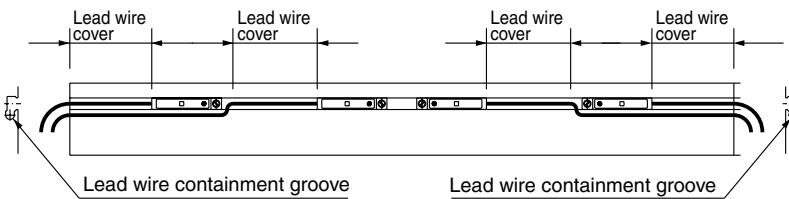

Fig. (1) Auto switch mounting position

2. How to mount auto switch/install lead wire cover

- 1) Insert and slide in the auto switch from the side of the cylinder and secure it with the screw provided. (Refer to Fig. (2).)
- 2) Cut the lead wire cover to the desired length using a cutter or tube cutter. (Refer to Fig. (1).)
- 3) First place the lead wires into the lead wire cover. Then, install a lead wire cover onto a cylinder body. (Refer to Fig. (3).)
- 4) Make sure that the lead wires do not interfere with the slide table at any stroke range.

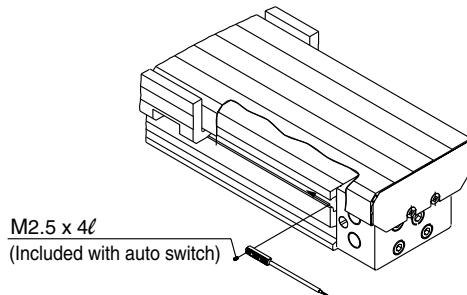

Fig. (2) Auto switch mounting

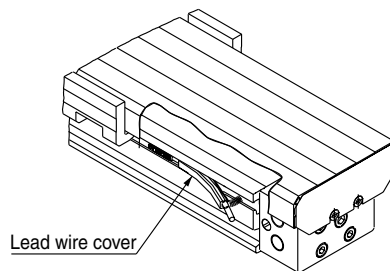

Fig. (3) Installation of lead wire cover

Other than the applicable auto switches listed in "How to Order", the following auto switches can be mounted. For detailed specifications, refer to page 8-30-1.

Type	Model	Electrical entry (Fetching direction)	Features
Reed switch	D-A90	Grommet (In-line)	Without indicator light
	D-Z80	Grommet (In-line)	

* Normally closed (NC = b contact), solid state switch (D-F9G/F9H/Y7G/Y7H type) are also available. For details, refer to page 8-30-31 to 8-30-32.

• D-A90 cannot be mounted on Series MY1HT.