

MODEL 3000R

**DESCRIPTION**

The Curtis enGage™ II is a dual function, microprocessor based instrument that can be factory or user defined to monitor various functions including fuel, temperature, pressure, voltage, battery state of charge and maintenance/status.

APPLICATION

Industrial and commercial vehicles including: material handling, outdoor power and construction equipment, engine driven stationary devices, commercial cleaning equipment, golf / light-on-road and other mobility aids. Also ideally suited for monitoring scheduled maintenance, warranty and leasing intervals.

QUALITY COMPLIANCE

Manufactured under ISO 9001 certified Quality Management system. UL recognized & CE certified.

FEATURES

- Multiple functions in one programmable unit:
 - Lower overall stocking requirements.
 - Reduced installation time and labor.
 - Reduced vehicle instrumentation count.
 - Ease of ordering.
 - Volume pricing/purchasing advantages.
- Field programmable maintenance monitor allows dealers and/or users to program maintenance intervals for their specific application.
- Optional settable hour meter allows replacement of a failed hour meter without loss of total elapsed time.
- Flexible output modes include flashing LCD segments, panel mounted LED and FET (0.5A) which allows the equipment designer to define critical parameters and to choose appropriate notification methods, such as alarms or buzzers.
- True Curtis battery monitoring technology means proven algorithm protection capabilities providing reliable state of charge information.
- Sealed front panel buttons allow easy:
 - Setting of maintenance interval.
 - Setting of battery monitoring profile.
 - Re-setting of maintenance hours.
 - Setting of total hour meter (optional).
- Clock function allows vehicle operator easy and safe access to time of day status.
- Mounting bracket and integrated connector lowers installation and production costs and eliminates traditional mounting hardware kits.
- EEPROM non-volatile memory retains usage data without battery back-up.
- Aesthetically attractive contemporary look enhances vehicle styling and maximizes readability. Overlays can easily be customized to create a specific brand/logo identity.
- Reliable, all solid state design means no moving parts minimizing warranty costs.
- Over 40 years of Curtis instrumentation design and manufacturing experience insures products are both innovative and extremely reliable.
- Curtis global network of sales and technical support provides timely and complete applications support.

CURTIS INSTRUMENTS, INC.

200 KISCO AVENUE
MT. KISCO, NY 10549 USA
TEL (914) 666-2971
FAX (914) 666-2188

CURTIS INSTRUMENTS, (UK) LTD.

5 UPPER PRIORY STREET
NORTHAMPTON NN1 2PT, ENGLAND
TEL 44 (0) 1604-629755
FAX 44 (0) 1604-629876

CURTIS INSTRUMENTS INDIA PRIVATE LTD.

1199, GHOLE ROAD
PUNE 411004, INDIA
TEL 91 (0) 20-5531288
FAX 91 (0) 20-5539192

MODEL 3000R

DIMENSIONS mm

12-48V Molex unit shown

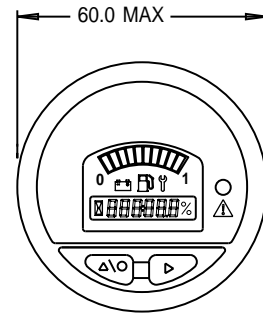
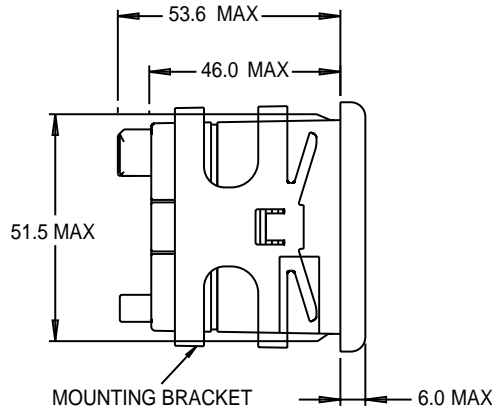
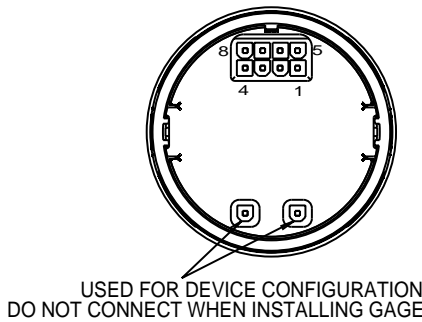

MOLEX CONNECTOR

PIN NO.	DESCRIPTION
1	Sense B
2	Keyswitch
3	FET Output
4	V-
5	Sense A
6	Setup Enable
7	Hourmeter Enable
8	V+

AMP CONNECTOR

PIN NO.	DESCRIPTION
1	Sense A
2	Setup Enable
3	Hourmeter Enable
4	V+
5	Sense B
6	Keyswitch
7	FET Output
8	V-

NOTES:

- 1.0 MATING CONNECTOR: 8-PIN MOLEX P/N 39-01-2085 WITH UL RATING 94V-0, PINS P/N 39-00-0039 FOR #18-24 AWG
- 2.0 MATING CONNECTOR; 8-PIN AMP P/N 794821-1 WITH UL RATING 94V-0, INTERFACE SEAL P/N 794772-0, WIRE SEAL 794758-1, PINS P/N 770904-X FOR #18-24 AWG
- 3.0 MATERIAL: CASE-POLYCARBONATE, LENS-CLEAR POLYMETHYLMETHACRYLATE (PMMA), COVER, OVERLAY & MOUNTING BRACKET-POLYCARBONATE.
- 4.0 THIS UNIT IS DESIGNED FOR A MOUNTING PANEL THICKNESS OF 0.8mm - 6.4mm.
- 5.0 52mm METERS ARE PROVIDED IN A STANDARD ROUND PACKAGE FOR MOUNTING IN A 52mm DIA DASH PANEL HOLE.

SPECIFICATIONS

- Operating voltages
12VDC nominal (9 to 15VDC)
12-48VDC nominal (9 to 60VDC)
- Operating temperature
-40°C to +85°C
- Storage temperature
-50°C to +90°C
- Humidity
95% RH (non-condensing) at +38°C
- Shock
SAE J 1378 March 83. Amplitude
44-55 g, half sine, 9-13 ms duration
- Vibration
SAE J 1378
Double amplitude of 1.53mm with
frequency sweep for 10-80-10 Hz
(20 g max) at 1 minute intervals

- Sealing

	FACE	REAR
Molex connector -	IP65	IP40
AMP connector -	IP65	IP65 (with connector installed)
- Output signal format (Power MOSFET)
N channel MOSFET (switches ground side only)
Programmable; capable of sinking up to 0.5A, maximum
- Adjustable BDI Discharge Profile Range
Full: 1.80 – 2.30 V/cell (Factory set at 2.04 V/cell)
Empty: 1.50 – 2.20 V/cell (Factory set at 1.73 V/cell)
100 mV/cell is minimum differential between full & empty
- BDI Open Circuit Reset Level factory set at 2.09 V/cell
- Maximum Current Ratings
12VDC Only Models: 35 mA @ 15VDC
12 – 48VDC Models: 35 mA @ 60VDC

NOTE - BDI, Maintenance Monitor, Settable Hour Meter and Time of Day functions require programming buttons on front display. Buttons NOT available on units rated 12VDC only.

OPTIONS & ACCESSORIES

17631800-01 – Amp Based Installation Kit

Includes a pre-assembled mating connector with over 5" of crimp-connect terminated wires and an installation booklet.

17631800-02 – Molex Based Installation Kit

Includes a pre-assembled mating connector with over 5" of crimp-connect terminated wires and an installation booklet.

WARRANTY Two year limited warranty from time of delivery.