

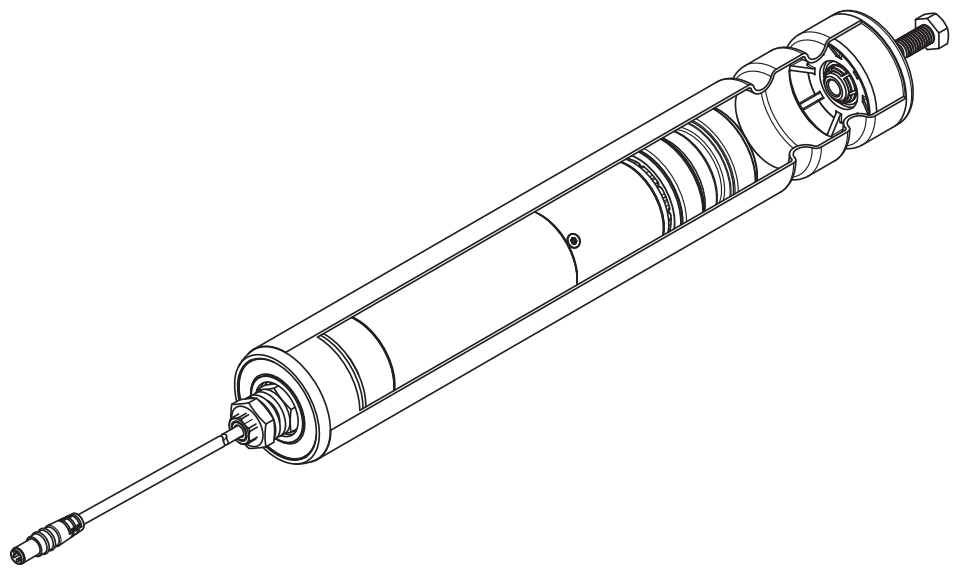

WE MAKE THE WORLD MOVE



# User manual

## Interroll RollerDrive EC310

**Manufacturer's address**

Interroll Engineering GmbH  
Hoeferhof 16  
D-42929 Wermelskirchen  
Tel. +49 2193 23 0  
Fax. +49 2190 2022  
[www.interroll.com](http://www.interroll.com)

**Copyright**

The copyright of this manual remains with Interroll Engineering GmbH. The operating instructions contain technical regulations and drawings which may not be reproduced partially or in full, transmitted by any means, utilized without permission for competitive purposes or disclosed to third parties.

## Table of contents

<b>Introduction</b>	
Information about the operating instructions . . . . .	2
Warnings in this manual . . . . .	2
Further symbols . . . . .	3
<b>Safety</b>	
General safety instructions . . . . .	4
Intended use . . . . .	4
Unintended use . . . . .	4
Qualified persons . . . . .	5
Dangers . . . . .	5
Interfaces . . . . .	6
Operating modes . . . . .	6
<b>Product information</b>	
Components . . . . .	7
Product Description . . . . .	8
RollerDrive Label . . . . .	9
Product Identification . . . . .	9
Technical Data . . . . .	10
Performance Data for RollerDrive EC310 . . . . .	10
DriveControls for the RollerDrive EC310 . . . . .	11
Speed Settings . . . . .	11
Motor Plug . . . . .	13
Dimensions of the Motor Shaft . . . . .	14
Dimensions of Bearing Seats on the Non-Drive Side . . . . .	14
Arrangement of Round Belt Grooves . . . . .	15
Conical RollerDrives . . . . .	15
<b>Transport and storage</b>	
Transport . . . . .	16
Storage . . . . .	16
<b>Assembly</b>	
Warning information for assembly . . . . .	17
Warning Notices for the Electrical Installation . . . . .	18
RollerDrive Installation . . . . .	19
Mounting tool . . . . .	21
Electrical Installation . . . . .	22
<b>Initial startup and operation</b>	
Commissioning . . . . .	23
Operation . . . . .	23
Procedure in case of accident or malfunction . . . . .	23
<b>Maintenance and cleaning</b>	
Warnings concerning maintenance and cleaning . . . . .	24
Maintenance . . . . .	24
Cleaning . . . . .	24
<b>Troubleshooting</b>	
Troubleshooting . . . . .	25
<b>Abandonment and disposal</b>	
Abandonment . . . . .	26
Disposal . . . . .	26
<b>Appendix</b>	
Accessories . . . . .	27
Installation Declaration . . . . .	28

## Introduction

### Information about the operating instructions

#### Contents

This manual contains important advice, notes and information about the RollerDrive EC310 in all phases of its lifecycle:

- Transport, assembly and start-up
- Safe operation, maintenance and troubleshooting, disposal
- Accessories

#### Validity of the manual

The manual describes the RollerDrive EC310 as it is delivered by Interroll.

In addition to this manual, special contractual agreements and technical documents apply to special versions.

#### The manual is part of the product

- For trouble-free, safe operation and warranty claims, read the manual and follow the instructions before handling the RollerDrive EC310.
- Keep the manual near to the RollerDrive EC310.
- Pass the manual on to any subsequent operator or occupant of the RollerDrive EC310.
- Interroll does not accept any liability for malfunctions or defects due to non-observance of this manual.
- If you have any questions after reading the operation manual, feel free to contact our customer service. See the last page for your local contact.

### Warnings in this manual

The warnings in this document refer to risks which may arise while using the RollerDrive EC310. For relevant warnings, see "Safety", page 4 and the warnings at the beginning of each chapter.

There are three categories of danger. The following signal words are used in the document as required:

- Danger
- Warning
- Caution

Signal word	Meaning
Danger	Indicates a hazardous situation which, if not avoided, will result in death or serious injury.
Warning	Indicates a hazardous situation which, if not avoided, could result in death or serious injury.
Caution	Indicates a hazardous situation which, if not avoided, may result in minor or moderate injury.

#### Structure of warnings



DANGER

**Nature and source of the hazard**  
Possible consequence of non-observance

- Information about how to avoid the hazard.

## Introduction

### Further symbols

#### **NOTICE**

**This symbol identifies possible material damage.**  
➤ Information about how to avoid damage.



This symbol displays safety instructions.



This symbol marks useful and important information.

➤ This symbol marks the steps that have to be carried out.

## Safety

### General safety instructions

The RollerDrive EC310 is designed according to the technical state of the art and is reliable in operation, once distributed. However, risks may still arise.

- Risks of physical injury to the user or bystanders.
- Adverse effects of the RollerDrive and other material.



Disregarding the warnings in this manual may lead to serious injury.

- Always read the entire operating and safety instructions before starting to work with the RollerDrive and follow the information contained herein in full.
- Only instructed and qualified persons may work with the RollerDrive.
- Always keep this user manual at hand when working on the RollerDrive so that you can consult it quickly if required.
- Always comply with relevant national safety regulations.
- If you have any questions after reading this user manual, feel free to contact our customer service. See the last page for contact information.

### Intended use

The RollerDrive EC310 may only be used for industrial applications and in an industrial environment to convey goods such as parts, cartons, totes or boxes. It must be integrated in a conveyor module or a conveying system. Any other use is not permitted.

Any changes that affect the safety of the product are not allowed.

The RollerDrive EC310 may only be used within the given operation limits.

### Unintended use

The RollerDrive EC310 may not be used to transport persons, bulk cargo or small parts.

The RollerDrive is not intended for use under impact or shock loads.

Applications not according to the intended use of the RollerDrive EC310 require approval from Interroll.

## Safety

### Qualified persons

Qualified persons are persons who read and understand the manual and, taking national regulations into account, can competently execute incidental work.

Only instructed and qualified persons may work with the RollerDrive, taking the following into account:

- the relevant manuals and diagrams,
- the warning and safety instructions in this manual,
- the system specific regulations and requirements,
- national or local regulations and requirements for safety and accident prevention.

### Dangers



The following list informs you about the various types of danger or damage that may occur while working with the RollerDrive EC310.

- |  |  |
|--|--|
| <b>Persons</b>                         | <ul style="list-style-type: none"><li>➤ Maintenance or repair work must only be executed by authorized and qualified persons in accordance with the applicable regulations.</li><li>➤ Before turning on the RollerDrive, ensure that no unauthorized persons are near the conveyor.</li></ul>  |
| <b>Electricity</b>                     | <ul style="list-style-type: none"><li>➤ Only perform installation and maintenance work after you have switched off the power. Ensure that the RollerDrive cannot be turned on accidentally.</li></ul>  |
| <b>Rotating parts</b>                  | <ul style="list-style-type: none"><li>➤ Keep your fingers and hair away from moving parts.</li><li>➤ If you have long hair, always wear a hair net.</li><li>➤ Never wear loose clothing.</li><li>➤ Never wear jewellery, such as necklaces or bracelets.</li><li>➤ Wear safety shoes.</li></ul>  |
| <b>Working environment</b>             | <ul style="list-style-type: none"><li>➤ Do not use the RollerDrive in explosive atmospheres.</li><li>➤ Always remove materials and objects which are not required from the work area.</li><li>➤ Wear safety shoes.</li><li>➤ Regulate and monitor careful placement of the goods on the conveyor.</li></ul>  |
| <b>Malfunctioning during operation</b> | <ul style="list-style-type: none"><li>➤ Regularly check the RollerDrive for visible damage.</li><li>➤ In case of fumes, unusual noise or blocked or damaged goods, stop the RollerDrive at once and ensure that the RollerDrive cannot be started accidentally.</li><li>➤ Contact qualified personnel immediately to find the source the malfunction.</li><li>➤ Do not step on the RollerDrive during operation.</li></ul> |
| <b>Maintenance</b>                     | <ul style="list-style-type: none"><li>➤ As the product is maintenance free, you only need to check regularly for visible damages, unusual noise and that the screws and nuts are still tightened.</li><li>➤ Do not open the RollerDrive.</li></ul>   |
| <b>Accidental start-up</b>             | <ul style="list-style-type: none"><li>➤ Make sure that the RollerDrive cannot start up accidentally, particularly during assembly, maintenance work and in the event of a fault.</li></ul>   |

## Safety

### Interfaces

By assembling the RollerDrive in a conveyor module, potential hazards may occur. These are not described in this manual and have to be analyzed during the design, installation, and startup of the conveyor module.

- After assembling the RollerDrive in a conveyor module, check the whole system for any new potential dangerous condition prior to turning on the conveyor.

### Operating modes

<b>Normal mode</b>	Operation of the installed device at the end customer's as a component in a conveyor in a complete system.
<b>Special mode</b>	All operating modes which are required to guarantee and maintain safe and normal operation.

Special operating mode	Explanation	Comment
<b>Transport/Storage</b>	Loading and unloading, transport and storage	-
<b>Assembly/Initial start-up</b>	Installation at the end customer's and performing the test run	When de-energized
<b>Cleaning</b>	External cleaning	When de-energized
<b>Maintenance/Repairs</b>	Maintenance and inspection tasks	When de-energized
<b>Troubleshooting</b>	Troubleshooting in the event of a fault	When de-energized
<b>Fault elimination</b>	Eliminating the fault	When de-energized
<b>Shut-down</b>	Dismantling from the conveyor	When de-energized
<b>Disposal</b>	Disposal of RollerDrive and packaging	-

## Product information

### Components

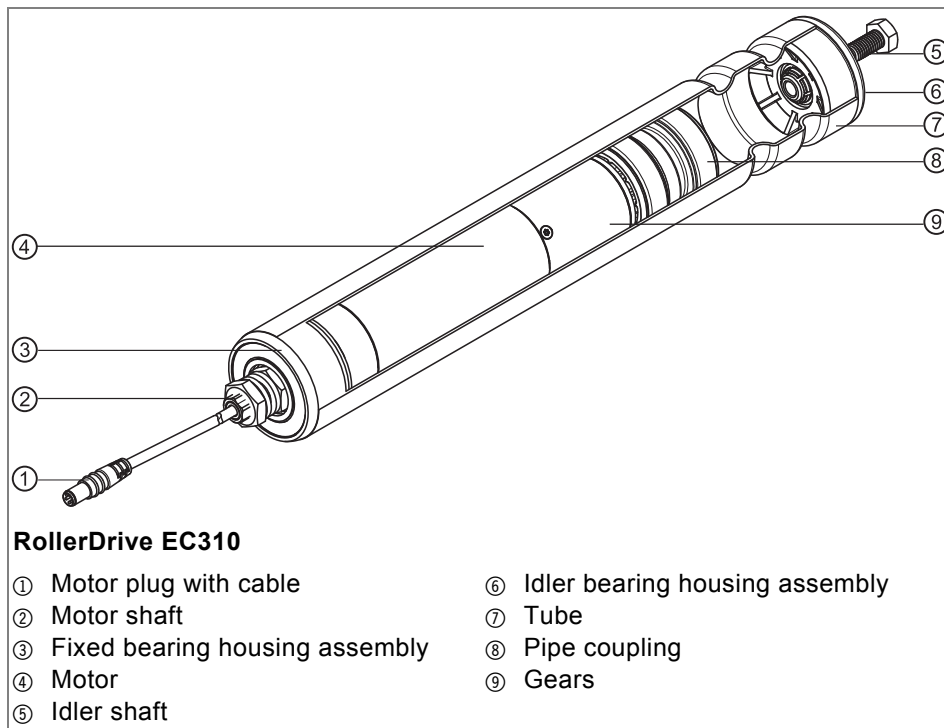

## Product information

### Product Description

The RollerDrive EC310 is an electronically commutated drive roller. The motor electronics, motors and gears are installed in the RollerDrive . It has nine gear stages and can be operated at a constant conveying speed.

#### Overload protection device

There are several overload protection systems.

- **Stall timing device:** If the RollerDrive is stalled while there is a run command, the motor tries to restart ten times every three seconds for one second. If the stall persists after these ten attempts, a failure signal is set and the RollerDrive tries to restart with a 60:1 cycle (restart for one second every 60 seconds) until the stall is eliminated. The RollerDrive will not be damaged if the system operates in a stall time device mode for a long period of time. If the RollerDrive is running at the selected speed again or the run command is withdrawn, the failure signal will be cancelled.
- **Slow running:** If there is a speed deviation of +/- 20% from the chosen value for more than 10 seconds, the motor will be switched off and the failure signal will be set. The RollerDrive will try to start again after 60 seconds. If the RollerDrive is running at the selected speed again or the run command is withdrawn, the failure signal will be cancelled.
- **Temperature monitoring:** The temperature of the motor and electronic assemblies is monitored.

If used appropriately, the roller can be installed in the conveyor with the required controls and then operated maintenance-free throughout the service life of the product.

#### Holding brake (Zero Motion Hold)

The RollerDrive EC310 is fitted with an electronic holding brake that allows it to be used on conveyors on a gradient or incline. The motor's rotor is held in position if no travel signal is pending. In the event of failure of the supply voltage, the holding brake becomes ineffective as it is not a mechanical brake.

#### Energy feedback

The RollerDrive EC310 feeds energy back when the goods being conveyed brake. This results in the motor heating up less in operation and improves the energy efficiency of the system. Interroll DriveControls are fitted with a switch that prevents the voltage rising above 28 V in the supply voltage. When installing the system, ensure that the power units are capable of feedback.

## Product information

### RollerDrive Label

The information on the RollerDrive label is used to identify the RollerDrive. This is necessary in order to use the RollerDrive as intended.

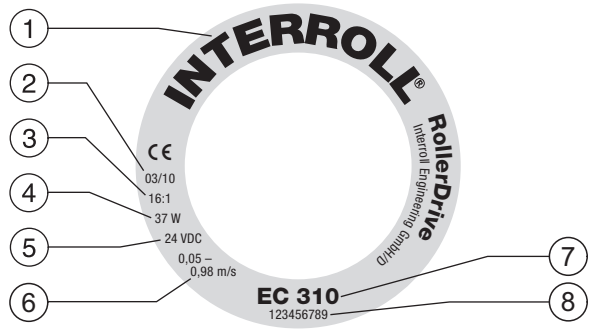

The diagram shows a circular label for the RollerDrive EC 310. The label contains the following information:
 

- 1: Manufacturer (INTERROLL)
- 2: Date of production (03/10)
- 3: Gear ratio (16:1)
- 4: Performance (37 W)
- 5: Rated voltage (24 VDC)
- 6: Speed range (0,05 – 0,98 m/s)
- 7: Type of RollerDrive (RollerDrive)
- 8: Serial number (123456789)

**Label**

① Manufacturer	⑤ Rated voltage
② Date of production	⑥ Speed range
③ Gear ratio	⑦ Type of RollerDrive
④ Performance	⑧ Serial number

### Product Identification

The following information is needed to identify a RollerDrive. You can enter the values of your RollerDrive in the last column.

Information	Possible value	Own value
RollerDrive label	Motor type Gear ratio Serial number	
Tube diameter	50 mm or 1.9 in	
Tube material	Zinc-plated, aluminium or stainless steel (with or without sleeves)	
Roller length	EL/BF	
Roller transmission	Torque transmission	
Idler shaft	Spring loaded or female threaded shaft pin (see "Dimensions of Bearing Seats on the Non-Drive Side", page 14)	

## Product information

### Technical Data

Rated voltage	24 VDC
Voltage range	18 to 28 VDC
Idle current	0.4 A
Rated current	2 A
Maximum peak current	5 A
Rated power	32 W
Power loss	12.5 W
Efficiency	70 %
Maximum ripple from power supply	3 %
Maximum number of starts/stops per minute	30
Maximum noise emission (mounted)	55 db(A) <sup>1)</sup>
Lifetime under nominal conditions	20000
Protection classification	IP54 and IP66
Ambient temperature in operation	0 °C to 40 °C (32 °F to 104 °F)
Ambient temperature during transport and storage	-30 °C to +75 °C (-22 °F to +167 °F)
Air humidity	5 to 85 %
Installation height above sea level	max. 1000 m (max. 3300 ft)



Mechanical performance, performance data and characteristic curves apply to an ambient temperature of 20 °C (68 °F).

<sup>1)</sup> Value can vary according to installation conditions, profile shapes and the resonance behaviour of the system.

### Performance Data for RollerDrive EC310

Gear ratio	Speed range m/s	Nominal torque Nm	Starting torque Nm	Holding torque Nm
4:1	0.20 to 3.93	0.20	0.49	0.16
9:1	0.09 to 1.75	0.45	1.10	0.36
12:1	0.07 to 1.31	0.61	1.46	0.48
16:1	0.05 to 0.98	0.81	1.95	0.64
24:1	0.03 to 0.65	1.21	2.92	0.96
36:1	0.02 to 0.44	1.82	4.38	1.44
48:1	0.02 to 0.33	2.42	5.85	1.92
64:1	0.01 to 0.25	3.23	7.80	2.56
96:1	0.01 to 0.16	4.84	11.69	3.84

## Product information

### DriveControls for the RollerDrive EC310

Interroll recommends using the RollerDrive EC310 in combination with the corresponding Interroll DriveControl 20 or 54.



For more detailed information on the DriveControl, please refer to the corresponding operating manual, relevant catalogues or publications at [www.interroll.com](http://www.interroll.com).

### Speed Settings

If you do not use the recommended DriveControl (see "DriveControls for the RollerDrive EC310", page 11), you may change the speed of the RollerDrive EC310 by altering the voltage on pin 5 of the motor plug.

#### Speed setting on the DriveControl

DIP switch setting on the DriveControl				Speed at gear ratio								
A	B	C	D	m/s								
				4:1	9:1	12:1	16:1	24:1	36:1	48:1	64:1	96:1
on	on	on	on	3.93	1.75	1.31	0.98	0.65	0.44	0.33	0.25	0.16
on	on	on	off	3.66	1.63	1.22	0.92	0.61	0.41	0.31	0.23	0.15
on	on	off	on	3.39	1.51	1.13	0.85	0.57	0.38	0.28	0.21	0.14
on	on	off	off	3.13	1.39	1.04	0.78	0.52	0.35	0.26	0.20	0.13
on	off	on	on	2.86	1.27	0.95	0.72	0.48	0.32	0.24	0.18	0.12
on	off	on	off	2.59	1.15	0.86	0.65	0.43	0.29	0.22	0.16	0.11
on	off	off	on	2.33	1.03	0.78	0.58	0.39	0.26	0.19	0.15	0.10
on	off	off	off	2.06	0.92	0.69	0.52	0.34	0.23	0.17	0.13	0.09
off	on	on	on	1.80	0.80	0.60	0.45	0.30	0.20	0.15	0.11	0.07
off	on	on	off	1.53	0.68	0.51	0.38	0.25	0.17	0.13	0.10	0.06
off	on	off	on	1.26	0.56	0.42	0.32	0.21	0.14	0.11	0.08	0.05
off	on	off	off	1.00	0.44	0.33	0.25	0.17	0.11	0.08	0.06	0.04
off	off	on	on	0.73	0.32	0.24	0.18	0.12	0.08	0.06	0.05	0.03
off	off	on	off	0.46	0.21	0.15	0.12	0.08	0.05	0.04	0.03	0.02
off	off	off	on	0.20	0.09	0.07	0.05	0.03	0.02	0.02	0.01	0.01
off	off	off	off	Stop or in accordance with the signals on the Speed A-C ports								

## Product information

### External speed setting via digital inputs

Speed input on the DriveControl *			Speed at gear ratio								
			m/s								
A	B	C	4:1	9:1	12:1	16:1	24:1	36:1	48:1	64:1	96:1
H	H	H	3.93	1.75	1.31	0.98	0.65	0.44	0.33	0.25	0.16
H	H	L	3.31	1.47	1.10	0.83	0.55	0.37	0.28	0.21	0.14
H	L	H	2.68	1.19	0.89	0.67	0.45	0.30	0.22	0.17	0.11
H	L	L	2.06	0.92	0.69	0.52	0.34	0.23	0.17	0.13	0.09
L	H	H	1.44	0.64	0.48	0.36	0.24	0.16	0.12	0.09	0.06
L	H	L	0.82	0.36	0.27	0.20	0.14	0.09	0.07	0.05	0.03
L	L	H	0.20	0.09	0.07	0.05	0.03	0.02	0.02	0.01	0.01
L	L	L	0	0	0	0	0	0	0	0	0

\* H = logically active; L = logically inactive

## Product information

### Motor Plug

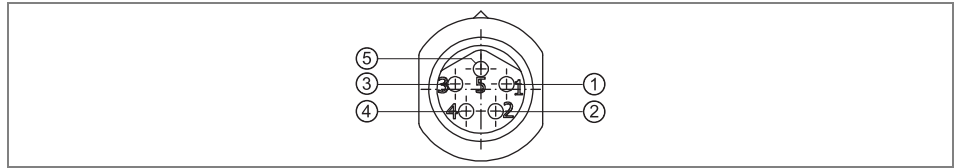

Pin	Colour	Function	Value
1	brown	Power supply input (+)	Rated voltage: 24 VDC Voltage range: 18 to 28 VDC
2	white	Direction of rotation, seen from the cable end of the RollerDrive	Low U < 0.8 V = counter clockwise High U > 2.4 V = clockwise
3	blue	Earth for power supply and signal (-)	Earth
4	black	Fault output	Open Collector $U_{cesat} = 0.5 \text{ V}$ for $I_c = 5 \text{ mA}$ $U_{max} = 30 \text{ V}$ $I_{cmax} = 5 \text{ mA}$
5	gray	Analogue speed/start signal	see table below

#### Analogue speed/start signal (Pin 5)

Voltage range	0 to 24 VDC
Stop (braked state)	0 to 2.3 VDC
Speed	2,3 VDC to 10 VDC (Incline rate above 2.3 VDC: 740 rpm (motor revolutions) linear between 2.3 and 10 VDC)
Max. speed	10 VDC to 24 VDC

The conveyor speed is calculated from the gear ratio and the nominal value.  
(also see "Speed Settings", page 11)



In case the RollerDrive is not directly connected to the corresponding DriveControl or the Interroll extension cable, connect the motor plug using a Conec M8 snap-in coupling.

### NOTICE

**Pins 1 and 3 are not protected against incorrect polarity connection.**

Damage to the motor.

➤ Ensure the correct polarity.

## Product information

### Dimensions of the Motor Shaft

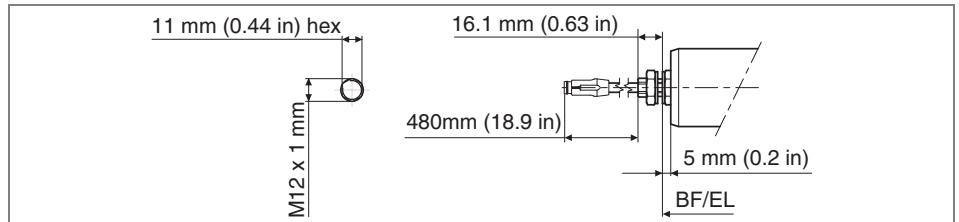

### Dimensions of Bearing Seats on the Non-Drive Side

**11 mm (0.44 in) hex,  
Spring-loaded shaft**

**Female threaded M8 (FTM8) shaft pin,**

Straight

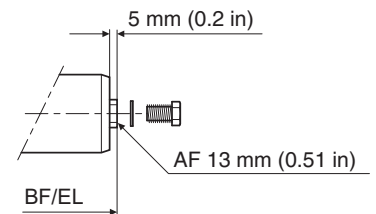
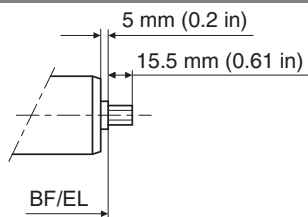

Round belt head

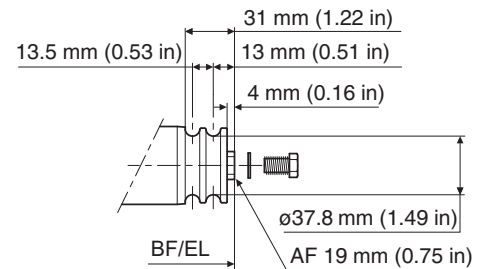
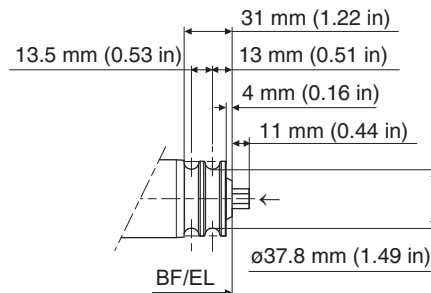

PolyVee head

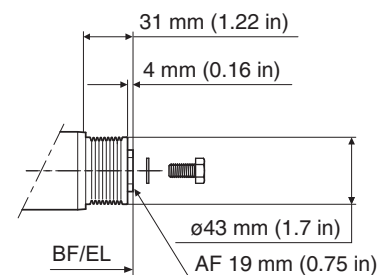
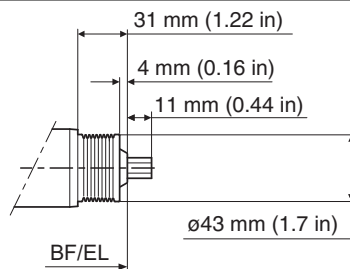

Toothed belt head

**Poly-Chain GT; 8 mm pitch; 18 teeth**

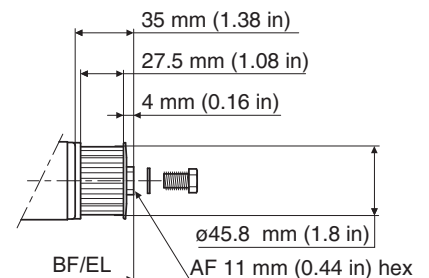

## Product information

	<b>11 mm (0.44 in) hex, Spring-loaded shaft</b>	<b>Female threaded M8 (FTM8) shaft pin,</b>
Sprocket head		11 mm (0.44 in) hex shaft; 3/8 in pitch; 20 teeth

BF/EL = Between Frames / Installation Length

### Arrangement of Round Belt Grooves

**IGM8 female thread shaft pin,  
single bearing**

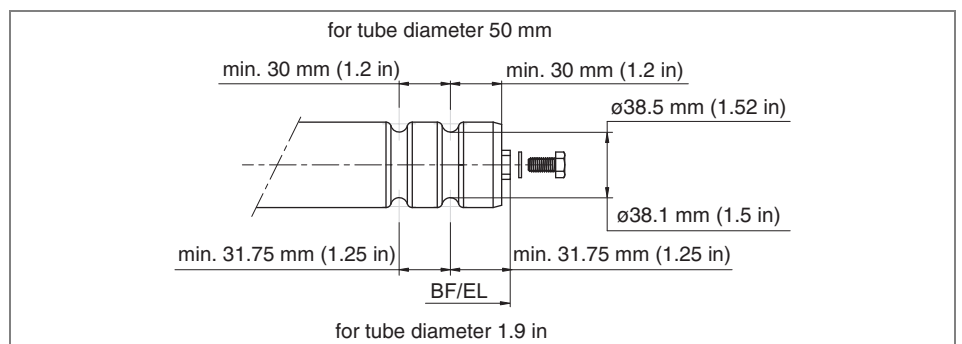

**Spring-loaded hex, double  
bearing**

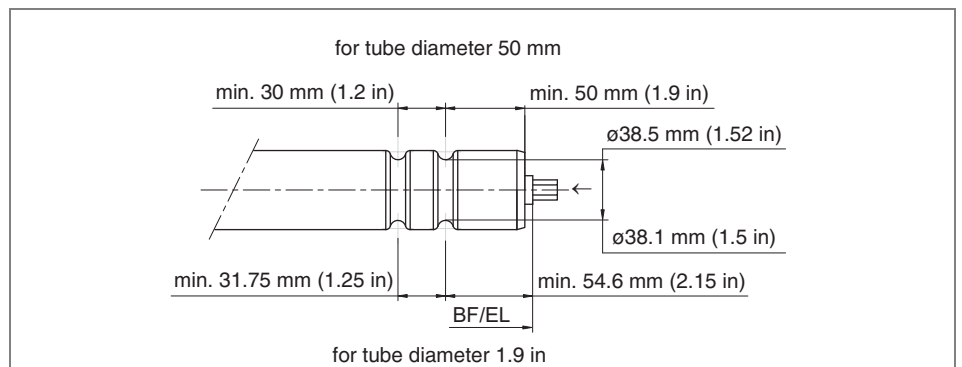

Other tube groove arrangements are possible.

### Conical RollerDrives

For conical RollerDrives there must be an 1.8° angle compensation on the motor end to avoid bending forces on the RollerDrive.

## Transport and storage

### Transport

- Every RollerDrive has end-protectors to cover its ends.

	<p><b>CAUTION</b></p> <p><b>There is a risk of injury if transported incorrectly</b></p> <ul style="list-style-type: none"> <li>➤ Only qualified and authorized persons should transport the product.</li> <li>➤ Follow the instructions below.</li> </ul>
---	--

- Do not stack pallets.
- Do not stack more than four cardboard boxes on top of each other.
- Check that the RollerDrives are correctly fixed prior to transport.
- Avoid serious impacts during transport.
- Check every RollerDrive for visible damage after transport.
- In the event of damage, take photos of the damaged parts.
- Report any damage caused by transport immediately to the transport company and Interroll to retain the right to claim for compensation.
- Do not expose the RollerDrives to serious fluctuations in temperature as this could lead to condensation.

### Storage

	<p><b>CAUTION</b></p> <p><b>Risk of injury due to improper storage</b></p> <ul style="list-style-type: none"> <li>➤ Do not stack pallets.</li> <li>➤ Do not stack more than four cardboard boxes on top of each other.</li> </ul>
---	---

- Check each RollerDrive for damage after storage.

## Assembly

### Warning information for assembly



#### **CAUTION**

##### **Rotating parts**

Risk of pinched fingers

- Do not insert fingers between the RollerDrive and the round belt, PolyVee belt or roller chain.
- Install a protection device (such as a guard plate) to prevent fingers from getting trapped in the round belt, PolyVee belt or roller chain.
- Install an appropriate warning on the conveyor.

#### **NOTICE**

**Risk of damage leading to failure or shortened life expectancy of the RollerDrive**

- Follow the instructions below.

- Do not drop or mishandle the RollerDrive to avoid internal damage.
- Check each RollerDrive visually for damage before assembly.
- In order to prevent damage to the internal connections, do not hold, carry or secure the RollerDrive by the motor cable.
- Do not force the RollerDrive when inserting it into the conveyor frame. It should fit easily into the holes in the frame.
- Ensure that the proper tightening torque is applied to the RollerDrive hex nut to prevent the shaft spinning in the frame and the wires twisting (see "*Securing the RollerDrive in the conveyor frame*", page 21).
- Do not twist the motor cable.

### Warning Notices for the Electrical Installation

#### **NOTICE**

##### **Risk of damage to the motor and/or RollerDrive cables**

➤ Observe the following safety information.

- All electrical work should only be performed by qualified and authorized persons.
- Disconnect the power before installing, removing or rewiring the RollerDrive.
- Do not apply AC current to the RollerDrive or DriveControl device at any time, as this will cause irreparable damage.
- Do not apply too much tension or pressure stress to the motor connector. Bending the cable and forcing the star washer over the cable can cause damage to the cable's insulation, which could result in failure of the RollerDrive.
- Ensure that the RollerDrive, the DriveControl and the 24 VDC power source are properly earthed through the conveyor frame or supporting structure in which the RollerDrive and the DriveControl are installed. Incorrect earthing can result in the build-up of static charge, causing the motor or DriveControl to malfunction or fail prematurely.
- Do not bend the motor cable at the motor shaft. Leave a minimum of 12 mm (0.5 in) of excess cable for stress relief.

## Assembly

### RollerDrive Installation

#### Inserting the motor shaft



- Remove the shipping tube from the RollerDrive.

Use caution when cutting the tie-wrap from the harness. Do not cut the sleeves or cables on the unit.

- Place the first star washer on the motor shaft.

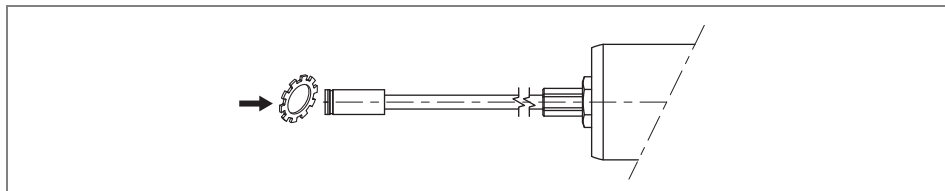

- Pass the motor cable through the 11 mm (0.44 in) hex hole in the conveyor frame and insert the motor shaft into the hex hole.

### NOTICE

#### Internal damage to the RollerDrive due to improper handling

- Do not yet fit the retaining nut.
- Do not bend the motor cable at the motor shaft. Leave a minimum of 12 mm (0.5 in) of excess cable for stress relief.

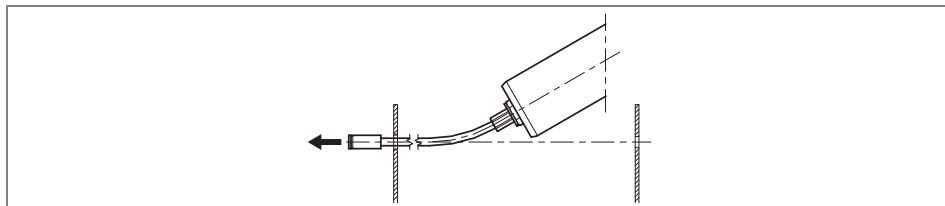

- Fit one or two round belts, size 4 mm, max. 5 mm (3/16 in) or RollerDrive belts (if used) on the non-driven end of the RollerDrive.

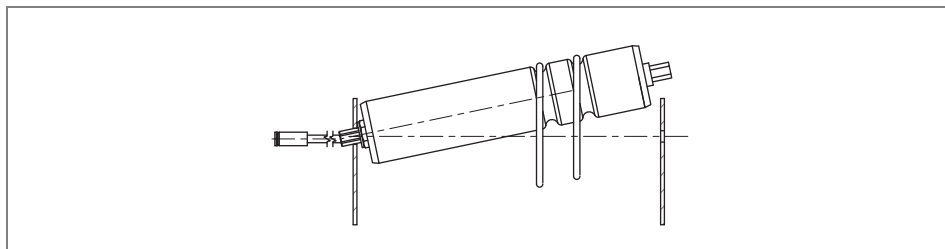

## Assembly

### Inserting the idler shaft

The type of axis dictates how the idler shaft is inserted in the conveyor frame. The spring-loaded shaft is simplest to install.

#### Inserting the spring-loaded hexagonal shaft

- Push the spring-loaded shaft inwards and align the shaft with the hole in the conveyor frame.

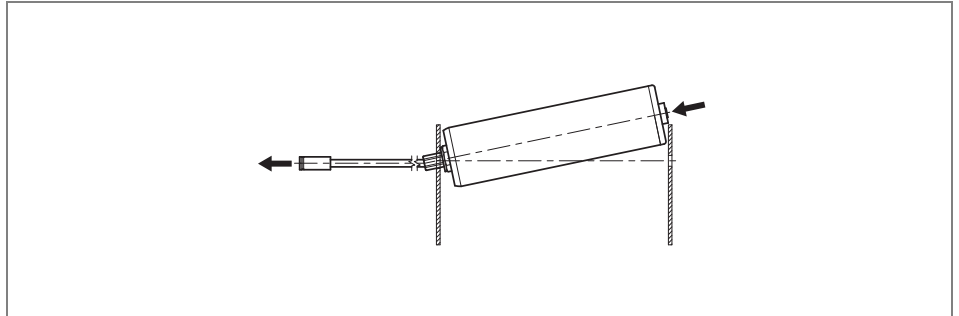

- Release the spring-loaded hexagonal shaft and allow it to pop into the hole in the frame.

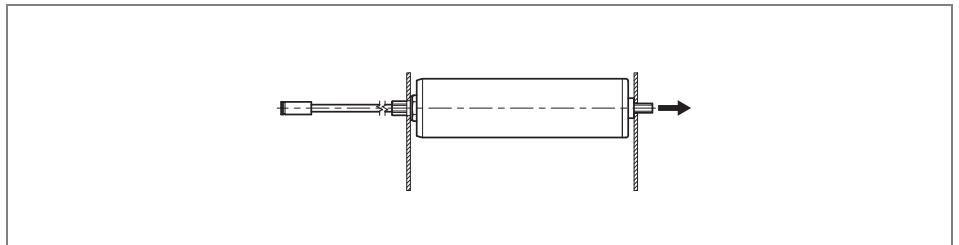

#### Inserting the FTM8 female thread shaft pin

- Place a split washer onto a M8 x 20 bolt.
- Align the RollerDrive with the hole in the conveyor frame and insert the M8 bolt and split washer into the shaft. Use a wrench to prevent the shaft pin from turning (width across flats AF 13 mm or AF 19 mm, depending on the shaft pin type, see "Arrangement of Round Belt Grooves", page 15).

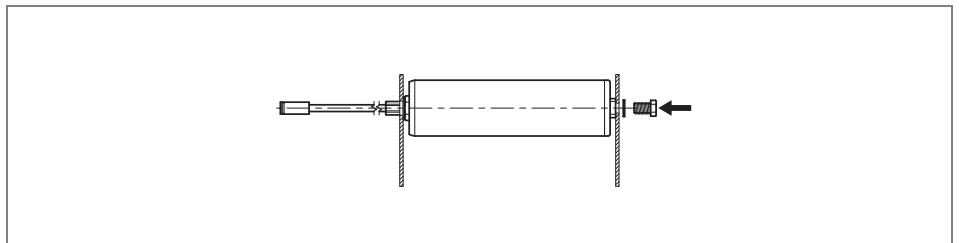

- Use a torque wrench to tighten the bolt with 20 Nm (177 in/lbf) until the split washer is completely compressed.

## Assembly

### Securing the RollerDrive in the conveyor frame

There is a nut and a retaining washer on the shaft next to the tube. This inner nut has been preassembled and secured in the correct position.



Do not adjust the inner nut and retaining washer.

- Use a flat wrench AF 19 mm to prevent the inner nut from turning. Use a flat wrench AF 36 mm with the IP66 configuration.
- Slip a second washer and a hex nut over the motor cable and screw it onto the threaded motor shaft. Ensure that washers are fitted on both sides of the profile.

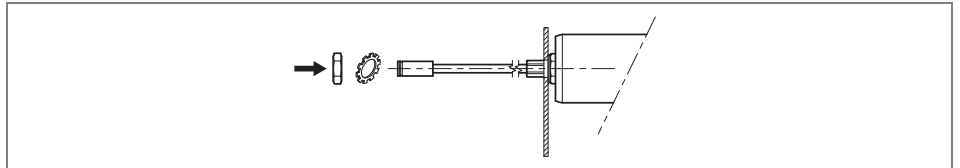

- Use a torque wrench to tighten this outer nut with 35 Nm (308 in/lbf) while ensuring that the inner nut is not rotating.



An angular compensation on the motor end is needed to prevent bending forces on conical RollerDrives.

### Mounting tool

For mounting the PolyVee belt, you may want to build a mounting tool as shown in the figure below.

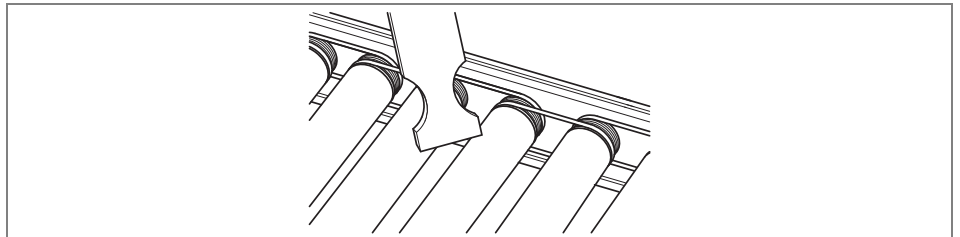

- Place the mounting tool between two rollers to reduce the gap between the adjacent rollers.

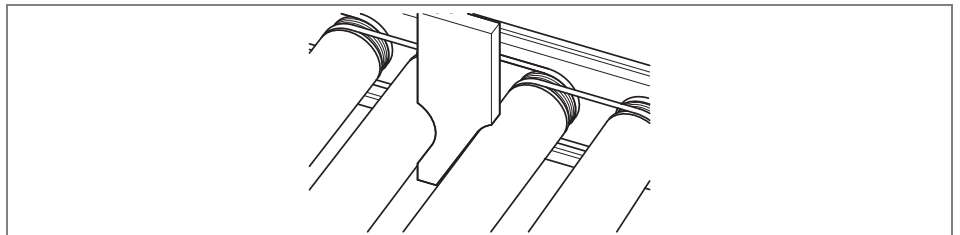

Dimensions of the mounting tool depend on the roller pitch and the roller tube diameter.

## Assembly

### Electrical Installation

- If the recommended DriveControl (see "*DriveControls for the RollerDrive EC310*", page 11) is used, connect the motor plug to the DriveControl.
- If the DriveControl is not used, connect your control to the motor plug (refer to see "*Motor Plug*", page 13 for the pin assignment)

## Initial startup and operation

### Commissioning



#### Pre-commissioning checks

- Ensure that no objects are in contact with rotating or moving parts.
- Ensure that all bolts are tightened according to the specifications.
- Ensure that there are no additional areas of danger caused by interfaces to other components.
- Ensure that the wiring is in accordance with the specification and legal directives.
- Check all protection devices.
- Ensure that no personnel stand in hazardous areas near the conveyor.



For information on commissioning, refer to the DriveControl manual or the manual for your motor control.

### Operation

	<div style="border: 1px solid black; padding: 5px; margin-bottom: 10px;">  <b>CAUTION</b> </div> <p><b>Rotating parts and accidental start-up</b> Risk of crushed fingers</p> <ul style="list-style-type: none"> <li>➤ Do not insert fingers between the RollerDrive and the round belt, PolyVee belt or roller chain.</li> <li>➤ Do not remove the protection device.</li> <li>➤ Keep fingers, hair and loose clothing away from the RollerDrive.</li> </ul>
---	--

	<b>NOTICE</b>
<p><b>Damage to the motor or the control due to induction</b></p> <ul style="list-style-type: none"> <li>➤ Do not push items along the roller conveyor by hand.</li> <li>➤ Do not spin the RollerDrive manually.</li> </ul>	

#### Pre-commissioning checks

- Check the RollerDrive for visible damage.
- Check all protection devices.
- Ensure that no personnel stand in hazardous areas near the conveyor.
- Clearly specify and monitor the way goods are placed on the conveyor.
- Ensure that the RollerDrive is not blocked.



Ambient conditions during operation see *"Technical Data"*, page 10

### Procedure in case of accident or malfunction

- Stop the conveyor at once and ensure that it cannot be started accidentally.
- In case of an accident: Provide first aid and call for emergency assistance.
- Inform responsible persons.
- Have the malfunction repaired by qualified persons.
- Start the conveyor only after this has been approved by qualified persons.

## Maintenance and cleaning

### Warnings concerning maintenance and cleaning



#### CAUTION

##### Risk of injury due to improper handling or accidental motor starts

- Maintenance work and cleaning may only be executed by qualified and authorized persons.
- Only perform maintenance work after switching off the power. Ensure that the RollerDrive cannot be turned on accidentally.
- Set up signs indicating maintenance work.

### Maintenance

#### Checking the RollerDrive

If the RollerDrive is not secured as specified in the installation instructions (see "Assembly", page 17), it may rotate in the hole in the conveyor frame. This will result in the roller leads becoming twisted and eventually severed.

- Monthly check the RollerDrive for visible damage.
- Annually ensure that the roller shaft is secured properly in the conveyor frame.

#### Replacing a RollerDrive

If a RollerDrive is damaged or broken down, it has to be replaced.

- Install a new RollerDrive (see "Abandonment", page 26 and see "RollerDrive Installation", page 19).

### Cleaning

Increased surface friction reduces the roller speed since more power is used to overcome the resistance. Therefore, in a dirty environment, periodic cleaning will ensure good contact with the goods and reduce friction.

- Remove foreign materials and dirt with a simple cleaning brush (not a wire brush) by brushing gently.
- Remove smaller amounts of dirt with a damp cloth. When doing this, make sure that wetting of the RollerDrive is no more than slightly damp.
- Do not use sharp-edged tools to clean the roller.

## Troubleshooting

### Troubleshooting



### CAUTION

#### Risk of injuries due to incorrect handling

- Troubleshooting may only be done by qualified and authorized persons.
- Only perform troubleshooting after switching off the power.
- Ensure that the RollerDrive cannot be turned on accidentally.

Symptom	Possible cause	Help
RollerDrive does not run	No power supply	Check 24 VDC power supply.
	Plug not connected properly	Check cable connection.
RollerDrive is rotating in the wrong direction or at the wrong speed	Wrong DriveControl settings on the speed and rotational direction Dip switches	Change setting on DriveControl.
	Wrong voltage at speed setting pin (if the RollerDrive is not operated with the recommended Interroll DriveControl)	Check the voltage of the speed setting pins on the motor plug.
Abnormal noise coming from the RollerDrive	Motor or gearbox is damaged	Replace the RollerDrive.
Interrupted RollerDrive operation	Damaged motor cable	Check motor cable for damage. If the motor cable is damaged, replace the RollerDrive.
	RollerDrive overloaded	<i>see "Overload protection device", page 8</i>

## Abandonment and disposal

### Abandonment



### CAUTION

#### Risk of injury due to improper handling

- Abandonment may only be executed by qualified and authorized persons.
- Only abandon the RollerDrive after switching off the power. Ensure that the RollerDrive cannot be turned on accidentally.

- Disconnect the motor cable from the control.
- Unscrew the outer nut at the threaded motor shaft.
- If the RollerDrive has a spring-loaded idler shaft, push the idler shaft inwards.
- If the RollerDrive has a FTM8 idler shaft, unscrew the bolt at the idler shaft.
- Extract the RollerDrive from the conveyor frame.

### Disposal

The operator is responsible for the proper disposal of the RollerDrive. In doing so, industry-specific and local provisions must be observed for the disposal of the RollerDrive and its packaging.

## Appendix

### Accessories

#### Belt

Part	Properties
Toothed belt	<ul style="list-style-type: none"> <li>• Gates Poly-Chain GT or similar: pitch 8 mm (0.31 in)</li> <li>• Toothed belt width: 11.2 mm (0.44 in)</li> <li>• Hub with 18 teeth</li> </ul>
Round belt	<ul style="list-style-type: none"> <li>• Belts with 4 mm (0.16 in) and max. 5 mm (0.20 in) diameter</li> </ul>
PolyVee belt	<ul style="list-style-type: none"> <li>• Drive head with 9 grooves for flexible V-ribbed belts</li> <li>• PJ form, ISO 9981, DIN 7867</li> <li>• Pitch 2.34 mm (0.09 mm)</li> <li>• Belts with a max. of 4 ribs</li> </ul>

#### DriveControls

Part	Part no.
DriveControl 20	89RA
DriveControl 54	89RB

#### Connection accessories

Part	Properties	Part no.
Connecting cable RollerDrive EC310 on DriveControl	Length: 2000 mm	89VN

## Appendix

### Installation Declaration

in accordance with the EC Machinery Directive 2006/42/EC, Appendix II B

#### The manufacturer:

Interroll Engineering GmbH  
Hoeferhof 16  
D - 42929 Wermelskirchen  
Germany

hereby declares with sole responsibility that the product range

- RollerDrive EC310

**is not a ready-to-use machine as defined by the EC Machinery Directive and, therefore, does not fully comply with the requirements of this directive. The commissioning of these conveyor modules is not permitted until conformity of the entire machine/system in which they are installed has been declared in compliance with the EC Machinery Directive.**

The health and safety requirements as stated in Appendix I have been applied. The special technical documents as stated in Appendix VII B have been compiled and will be sent to the responsible authority if necessary.

Person authorized to compile the technical documents: Georg Malina, Interroll Engineering GmbH, Hoeferhof 16, D - 42929 Wermelskirchen

#### Applied EC directives:

- Machinery Directive 2006/42/EC
- EMC Directive 2004/108/EC
- RoHS Directive 2002/95/EC

#### Applied harmonized standards:

- EN ISO 12100 Parts 1 and 2 "Safety of machinery - Basic concepts, general principles for design" - Part 1: "Basic terminology, methodology" - Part 2: "Technical principles"

Wermelskirchen, 31st March 2010

Armin Lindholm  
(Managing Director)

(This declaration can be obtained at [www.interroll.com](http://www.interroll.com), if needed.)





## Northern Europe

### Denmark

Interroll Nordic A/S  
Hammerholmen 2-6  
DK-2650 Hvidovre/Denmark  
Tel. +45 36 88 33 33  
Fax +45 36 88 33 72  
dk.sales@interroll.com

Interroll Service  
Tel. +45 36 88 33 88

### Iceland

IBH ehf  
Dugguvogur 10  
104 Reykjavik  
Iceland  
Tel. +354 562 6858  
Fax +354 562 6862  
is.sales@interroll.com

### Finland

Tel. +358 9 54 94 94 00  
Fax +358 9 54 94 94 16  
fi.sales@interroll.com

### Norway

Tel. +47 32 88 26 00  
Fax +47 32 88 26 10  
no.sales@interroll.com

### Sweden

Tel. +46 35 227077  
Fax +46 35 227078  
se.sales@interroll.com

## Western/Southern Europe

### France

Interroll S.A.S.  
ZI de Kerannou  
B.P. 34  
F-29250 Saint Pol de Léon  
Tel. +33 298 24 41 00  
Fax +33 298 24 41 02  
fr.sales@interroll.com

### Italy

Rulli Rulmeca S.p.A.  
Via A. Toscanini, 1  
I-24011 Almè (Bg)  
Tel. +39 035 4300111  
Fax +39 035 545523  
vendita@rulmeca.it

### Portugal

Rulmeca Interroll de Portugal Lda  
Apartado 69, Centro Civico  
P-6201-909 Covilhã  
Tel. +351 275 330 780  
Fax +351 275 990 789  
rulmeca@rulmeca-interroll.pt

### Spain

Interroll España S.A.  
Parc Tecnològic del Vallès  
C/Dels Argenters, 5  
Edificio 1, módulos Bp y Cp  
E-08290 Cerdanyola del Vallès  
Tel. +34 90 211 0860  
Fax +34 93 586 4895  
es.sales@interroll.com

### United Kingdom

Interroll Ltd.  
Brunel Road  
Earlshires Industrial Estate  
GB-Corby, Northants NN17 4UX  
Tel. +44 1536 200 322  
Fax +44 1536 748 515  
gb.sales@interroll.com

## Central Europe

### Germany

Interroll Fördertechnik GmbH  
Höferhof 16  
D-42929 Wermelskirchen  
Tel. +49 2193 23 0  
Fax +49 2193 20 22  
de.sales@interroll.com

### Austria

Tel. +49 2193 23 187  
Fax +49 2193 23 164

### Belgium

Tel. +49 2193 23 131  
Fax +49 2193 23 164  
be.sales@interroll.com

### Luxembourg

Tel. +49 2193 23 190  
Fax +49 2193 23 164

### Netherlands

Tel. +49 2193 23 151  
Fax +49 2193 23 164

### Switzerland

Tel. +49 2193 23 190  
Fax +49 2193 23 164  
ch.sales@interroll.com

## Eastern Europe

### Czech Republic

Interroll CZ, s.r.o.  
Na Rádku 7/3172  
CZ-69002 Břeclav  
Tel. +420 519 330 210  
Fax +420 519 330 211  
cz.sales@interroll.com

### Hungary

Tel. +36 23 337 891  
Fax +36 23 337 892  
hu.sales@interroll.com

### Poland

Interroll Polska Sp. z o.o.  
ul. Płochocińska 85  
PL-03-044 Warszawa  
Tel. +48 22 741 741 0  
Fax +48 22 741 741 1  
pl.sales@interroll.com

### Slovakia

Tel. +421 2 4363 8102  
Fax +421 2 4342 7294  
sk.sales@interroll.com

### Slovenia

Tel. +386 1 56 56 370  
Fax +386 1 56 56 372

### Turkey

Rol-er Makina San. Ve. Tic. Ltd. Sti.  
Pembegul Sok., Dostlar Apt.  
No. 12 D. 10 Suadiye  
347 40 Istanbul  
Turkiye  
Tel. +90 216 386 37 75  
Fax +90 216 386 38 22  
tr.sales@interroll.com

## Middle East

### Israel

ComTrans-Tech Ltd.  
P.O.B. 17433  
Tel-Aviv 61174  
Israel  
Tel. +972 54 4 27 27 47  
Fax +972 3 7 44 08 64  
il.sales@interroll.com

## Africa

### South Africa

Interroll SA Pty. Ltd.  
P.O. Box 327  
Isando 1600  
37 Director Road, Spartan Ext 2  
1619  
South Africa  
Tel. +27 11 281 9900  
Fax +27 11 252 9083  
za.sales@interroll.com

## North & South America

### USA

Interroll Corporation  
3000 Corporate Drive  
USA-Wilmington, NC 28405  
Tel. +1 910 799 11 00  
Fax +1 910 392 38 22  
us.sales@interroll.com

### Canada

Interroll Components Canada Ltd.  
8900 Keele Street  
Unit 2 & 3  
Concord, Ontario L4K 2N2  
Canada  
Tel. +1 905 660 4426  
Fax +1 905 660 4159  
ca.sales@interroll.com

### Interroll Canada Ltd.

Drives & Rollers Canada  
1201 Gorham Street  
Newmarket Ontario L3Y 8Y2  
Canada  
Tel. +1 905 727 3399  
Fax +1 905 727 3299  
ca.sales@interroll.com

### Brasil

Interroll Logística Ltda.  
Rua Dom João VI, 555  
Parque Industrial S/A  
Pindamonhangaba-SP  
CEP 12412 - 805  
Brasil  
Tel. +55 12 3648 8021  
br.sales@interroll.com

## For other countries in

### South America, please contact:

Interroll España S.A.  
Parc Tecnològic del Vallès  
C/Dels Argenters, 5  
Edificio 1, módulos Bp y Cp  
E-08290 Cerdanyola del Vallès  
Tel. +34 90 211 0860  
Fax +34 93 586 4895  
es.sales@interroll.com

## Asia

### China

Interroll (Suzhou) Co. Ltd.  
Unit 10B, Modern Industrial Square  
No. 333 Xing Pu Road  
Suzhou Industrial Park  
Suzhou, Jiangsu Province  
People's Republic of China  
Postal Code: 215126  
Tel. +86 512 6256 0383  
Fax +86 512 6256 0385  
cn.sales@interroll.com

### Japan

Interroll Japan Co. Ltd.  
302-1 Shimokuzawa  
Sagamihara-shi  
Kanagawa 229-1134  
Japan  
Tel. +81 42 764 2677  
Fax +81 42 764 2678  
jp.sales@interroll.com

### Korea

Interroll Korea Corporation  
Room 301, Dongsan Bldg, 333-60  
Shindang-Dong, Choong-ku  
Seoul  
Korea  
Tel. +822 2 231 1900  
Fax +822 2 254 36 83  
kr.sales@interroll.com

### Singapore

Interroll (Asia) Pte. Ltd.  
386 Jalan Ibrahim  
629156 Singapore  
Republic of Singapore  
Tel. +65 6266 6322  
Fax +65 6266 6849  
sg.sales@interroll.com

### Thailand

Interroll (Thailand) Co. Ltd.  
41/6 Moo 6, Bangchalong,  
Bangplee  
Samutprakarn 10540  
Thailand  
Tel. +66 2 337 0188 91  
Fax +66 2 337 01 92  
th.sales@interroll.com

### India

Interroll Drives and Rollers India Pvt Ltd.  
SF 12, KSSIDC Building, 10<sup>th</sup> Main, III Stage  
Peenya Indl. Estate  
Bangalore - 560058  
India  
Tel. +91 80 2836 4996  
Fax +91 80 4117 0559  
in.sales@interroll.com

## Australia & New Zealand

### Australia

Conveyor Solutions Australia Pty. Ltd.  
70 Keon Parade  
Thomastown  
VIC 3073  
Australia  
Tel. +61 3 9460 2155  
Fax +61 3 9460 2029  
au.sales2@interroll.com

### New Zealand

Automation Equipment (NZ) Ltd.  
45 Colombo Street  
Frankton  
Hamilton  
New Zealand  
Tel. +64 7847 2082  
Fax +64 7847 7160  
nz.sales@interroll.com

## For other countries please see contacts at

www.interroll.com