

Type: 45 PUVR & 45 POVVR

Three Phase, Voltage Relay

The unit is designed to monitor a three phase, 3 wire supply for an under voltage condition (45PUVR) or an over voltage condition (45POVR). The 45PUVR relay de-energises when the monitored supply drops below the adjustable trip point. The relay re-energises when the supply rises above the trip point plus the hysteresis. The 45POVR functions by energising the relay when the voltage rises above the trip point. The relay de-energises when the supply drops below the trip point minus the hysteresis. A green LED indicates the supply is present whilst a red LED indicates the relay is energised. Note: During phase loss, the relay will de-energise on both units.



TIMING DIAGRAM

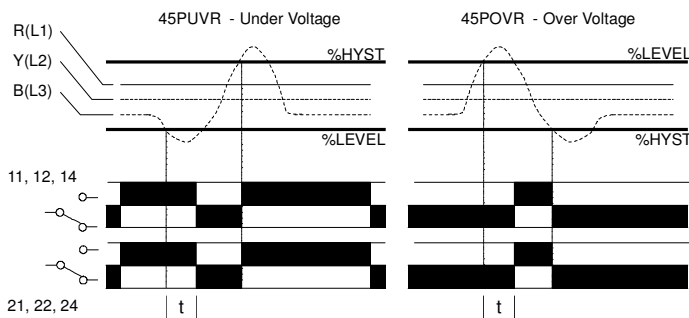

INSTALLATION AND SETTING

BEFORE INSTALLATION, ISOLATE THE SUPPLY. Connect the supply as shown in diagram below. Apply power and the green 'supply on' LED should illuminate.

45PUVR: The red 'relay' LED should illuminate and the relay energise if the supply voltage is above the set '% level'

45POVR: The red 'relay' LED should remain extinguished and the relay de-energised if the supply voltage is below the set '% level'

If on either unit the green LED illuminates but the red LED and relay indicate a fault, then check all connections and voltages present.

Set the '% level' and the '% hyst' adjustments as required. If large phase variations are anticipated and acceptable, the '% level' and the '% hyst' settings should be adjusted further to avoid false tripping.

Note: During phase loss, both LED's may be extinguished. Where monitoring a supply for correct phase sequence is important, the 45PSR Phase Sequence Relay should be used.

CONNECTION DIAGRAM

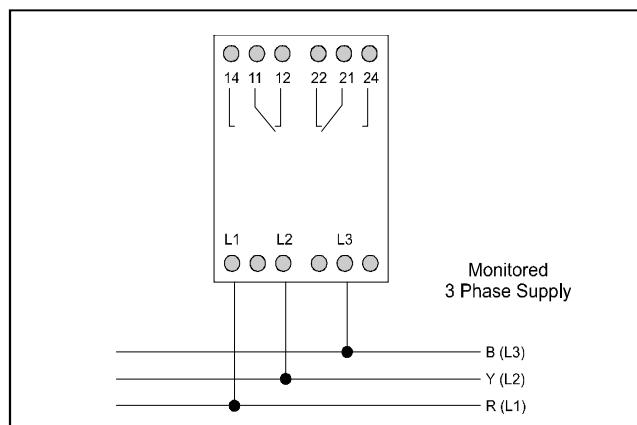

TECHNICAL SPECIFICATION

Supply/Monitored

Voltage Un: 380, 400V AC 45 - 65Hz
(phase to phase) (Galvanic isolation by transformer)

Supply Variation: 75 - 125% of Un

Isolation: Over voltage cat. III (IEC 664)

Overload: 1.5 x Un continuous
2 x Un for 3 seconds

Power

Consumption: 0.2VA @ Un (blue phase only)
3VA @ Un (red and yellow phases)

Trip Level: 75 - 100% Under voltage (45PUVR)
100 - 125% Over voltage (45POVR)

Hysteresis: 1 to 15% (user adjustable)

Repeat Accuracy: ± 0.5% at constant conditions

Reaction Time (t): ≈ 200mS (see Options 1 & 2)

Ambient

Temperature: -20 to +60°C

Relative Humidity: +95%

Contact Rating:

DPDT

AC I 250V AC 8A (2000VA)

AC 15 250V AC 3A

DC I 25V DC 8A (200W)

Electrical Life: Minimum 150,000 ops at rated load

Housing: Orange flame retardant UL94 VO

Weight: 300g approx.

Mounting Option: Onto 35mm symmetric DIN rail
to BS5584:1978
(EN50 002, DIN 46277-3)

Terminal

Conductor Size: Max 2 x 1.5mm² stranded (terminated)
Max 2 x 2.5mm² solid

Approvals:

Conforms to: UL, CUL, CSA, IEC.

CE Compliant

OPTIONS

- The above units can be supplied with an internally set time delay which prevents the relay from changing state immediately the supply voltage passes the trip point. The delay (ranging from 1 to 10 seconds) should be specified, prior to ordering.
- Where it is necessary for the user to set the time delay, the unit can be supplied with the hysteresis adjustment replaced with a time delay adjustment. On these units, the delay is adjustable from 0.2 to 10 seconds. The hysteresis is then factory set to 1%.

Broyce Control Ltd., Pool Street, Wolverhampton, West Midlands WV2 4HN. England

Telephone: +44 (0) 1902 773746 Facsimile: +44 (0) 1902 420639 Email: sales@broycecontrol.com

45P_VR-2-A.DOCX
1904

The information provided in this literature is believed to be accurate (subject to change without prior notice); however, use of such information shall be entirely at the user's own risk.