

Basic Switches

Double-pole Double-throw



FEATURES

- Two independent single-pole double-throw circuits on one housing
- Design permitting several wiring combinations
- Savings in space and weight
- Mounting interchangeability with type Z switches
- Temperature tolerance to +180°F (82°C)
- UL recognized, CSA certified

AVAILABLE TERMINALS

B6
6-32 UNC x .188"
(No. 5 pan head screws)

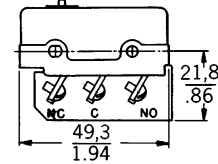

A7
4-40 UNC x .125"
Screws with lockwashers.
Fiberglass insulator isolates terminals and prevents accidental shorting.

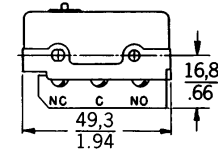

ELECTRICAL RATING

Circuitry	Electrical Data and UL Codes
Double-pole double-throw 	J 10 amps, 125 or 250 vac; 0.3 amp, 125 vdc; 0.15 amp, 250 vdc. UL Code L59

Characteristics: O.F. — Operating Force; R.F. — Release Force; P.T. — Pretravel; O.T. — Overtravel; D.T. — Differential Travel; O.P. — Operating Position.

DOUBLE-POLE DOUBLE-THROW



Dim. Dwg. Fig. 1

ORDER GUIDE

Catalog Listing	Description	Electrical Data and UL Code	O.F. max. newtons ounces	R.F. min. newtons ounces	P.T. max. mm inches	O.T. mm inches	D.T. max. min. mm inches	O.P.* mm inches
DT-2R-A7	Pin plunger	10 Amps J	3,34-5,56 12-20	0,56 2	1,91 .075	0,13 .005	1,02-1,52 .040-.060	15,6 .615±.015



Dim. Dwg. Fig. 9

DT-2RS1-A7	Straight plunger	10 Amps J	3,34-5,56 12-20	0,28 1	1,91 .075	0,51 .020	1,02-1,52 .040-.060	28,2±0,38 1.11±.015
-------------------	------------------	---------------------	---------------------------	------------------	---------------------	---------------------	-------------------------------	-------------------------------



Dim. Dwg. Fig. 3

DT-2RV3-A7	Straight lever Reversed lever position	10 Amps J	1,11-1,95 4-7	0,14 0.5	6,86 .270	0,25 .010	2,92-4,83 .115-.190	18,3 .719
-------------------	--	---------------------	-------------------------	--------------------	---------------------	---------------------	-------------------------------	---------------------



Dim. Dwg. Fig. 2

DT-2RV-A7	Straight lever	10 Amps J	0,97-1,67 3.5-6	0,28 1	25,4 1	1,57 .062	12,4-19,2 .490-.755	21,8 .859
------------------	----------------	---------------------	---------------------------	------------------	------------------	---------------------	-------------------------------	---------------------

Except where stated * ±0.76 mm ±.030 in.

Basic Switches

Double-pole Double-throw

ORDER GUIDE



Dim. Dwg. Fig. 8

Catalog Listing	Recommended For	Electrical Data and UL Codes	O.F. max. newtons ounces	R.F. min. newtons ounces	P.T. max. mm inches	O.T. min. mm inches	D.T. max. mm inches	O.P.* mm inches
DT-2RV216-A7	Roller lever (centered steel roller)	10 Amps J	11,1 2.5 lbs.	1,11 4	1,02 .040	0,13 .005	0,51-0,76 .020-.030	31 1.219



Dim. Dwg. Fig. 5

DT-2RV22-A7	1.03 inch (26,2mm) roller lever (steel roller)	10 Amps J	2,5-4,17 9-14	0,83 3	-	0,79 .031	4,95-7,75 .195-.305	30,2±0,38 1.188±.015
-------------	--	--------------	------------------	-----------	---	--------------	------------------------	-------------------------



Dim. Dwg. Fig. 7

DT-2RV212-A7	Roller lever Reversed lever position	10 Amps J	2,5-4,17 9-15	0,42 1.5	3,3 .130	0,13 .005	1,27-2,16 .050-.085	29,4 1.156
--------------	--------------------------------------	--------------	------------------	-------------	-------------	--------------	------------------------	---------------



Dim. Dwg. Fig. 6

DT-2RV23-A7	Roller lever Reversed lever position	10 Amps J	1,53-2,64 5.5-9.5	0,21 .75	4,45 .175	0,25 .010	2,16-3,43 .085-.135	29,4 1.156
-------------	--------------------------------------	--------------	----------------------	-------------	--------------	--------------	------------------------	---------------

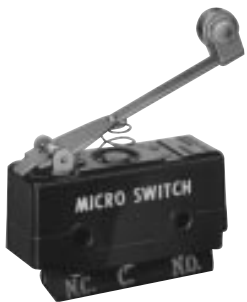

Dim. Dwg. Fig. 4

DT-2RV2-A7	1.90 inch (48,3 mm) roller lever (steel roller)	10 Amps J	1,25-2,09 4.5-7.5	0,42 1.5	— —	1,19 .047	9,27-14,4 .365-.565	31,8 1.250
------------	---	--------------	----------------------	-------------	--------	--------------	------------------------	---------------

Except where stated * ±0,76 mm ±.030 in.

Auxiliary actuators see page 68-69.

Standard Basic Switches

Basic Switches

DT Series

Double-pole Double-throw

MOUNTING DIMENSIONS (For reference only)

PIN PLUNGER

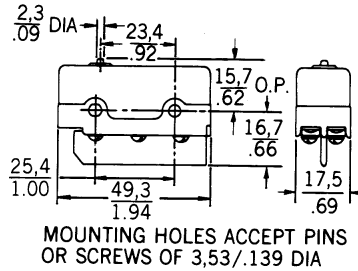

Fig. 1

STRAIGHT LEVER

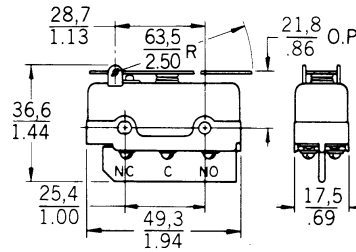

Fig. 2

STRAIGHT LEVER

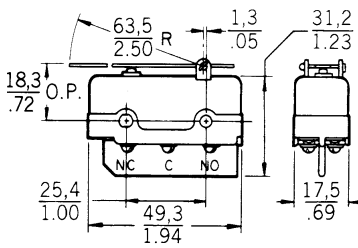

Fig. 3

ROLLER LEVER

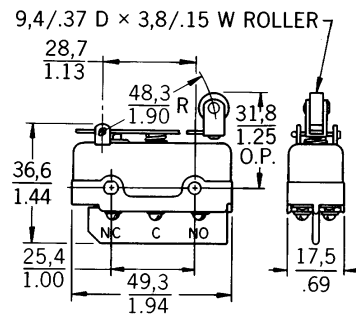

Fig. 4

Key: $\frac{0,0}{0.00} = \frac{\text{mm}}{\text{inches}}$

Basic Switches

DT Series

Double-pole Double-throw

MOUNTING DIMENSIONS (For reference only)

ROLLER LEVER

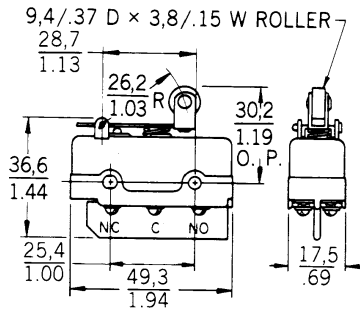

Fig. 5

ROLLER LEVER

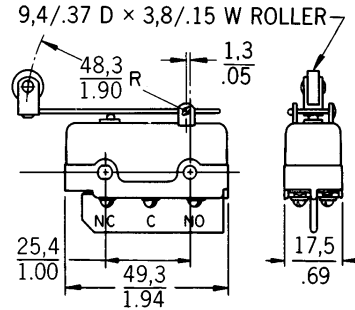

Fig. 6

ROLLER LEVER

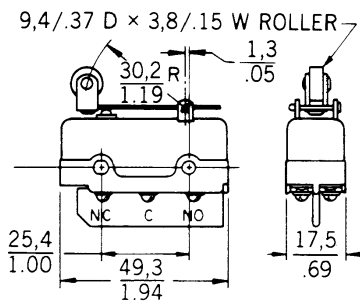

Fig. 7

ROLLER LEVER

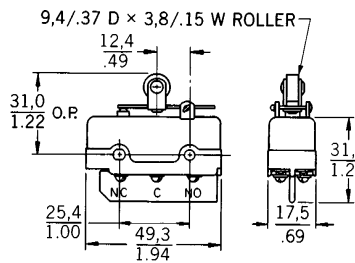

Fig. 8

STRAIGHT PLUNGER

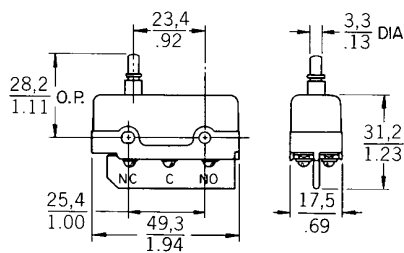

Fig. 9

Standard
Basic Switches