

# Studio White LED Emitter

## LZC-00SW00

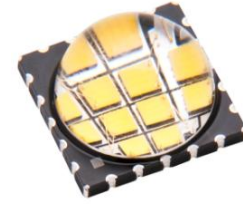

### Key Features

- 12-die Studio White (5300K) LED
- CCT and color rendering matched to HID arc lamp
- CRI85 minimum / R9 50 typical
- Up to 42 Watt power dissipation on compact 9.0mm x 9.0mm footprint
- Industry lowest thermal resistance per package size (0.7°C/W)
- Engineered ceramic package with integrated glass lens
- JEDEC Level 1 for Moisture Sensitivity Level
- Lead (Pb) free and RoHS compliant
- Reflow solderable (up to 6 cycles)
- Emitter available with several MCPCB options
- Full suite of TIR secondary optics family available

### Typical Applications

- Studio Lighting
- Photography Lighting
- High-end retail Lighting
- Showrooms Lighting

### Description

The LZC-00SW00 Studio White LED emitter features CCT and color rendering matched to HID arc lamps used in studio lighting. It delivers a daylight color temperature of 5300K, CRI greater than 85 and R9 red content of 50, resulting in a natural color rendering of skin tones and other colors, which cannot be obtained by standard daylight white LED emitters. The emitter, based on LED Engin's LuxiGen technology platform, may be driven up to 42W of power in a compact 9.0mmx9.0mm footprint. It has the industry lowest thermal resistance per package size, which allows users to drive the emitter with higher current, while keeping the junction temperature low to ensure long operating life.

## Part number options

### Base part number

Part number	Description
LZC-00SW00-xxxx	LZC Studio White emitter
LZC-70SW00-xxxx	LZC Studio White emitter on 1 channel 1x12 Star MCPCB
LZC-C0SW00-xxxx	LZC Studio White emitter on 2 channel 2x6 Star MCPCB
LZC-E0SWT1-xxxx	LZC Studio White emitter on 1 channel 1x12 Connectorized MCPCB
LZC-F0SWT1-xxxx	LZC Studio White emitter on 1 channel 2x6 Connectorized MCPCB

### Bin kit option codes

SW, Studio-White (5300K)			
Kit number suffix	Min flux Bin	Color Bin Ranges	Description
0000	Y	2D, 2C, 3A, 3B	full distribution flux; full distribution CCT

## Studio White Chromaticity Groups

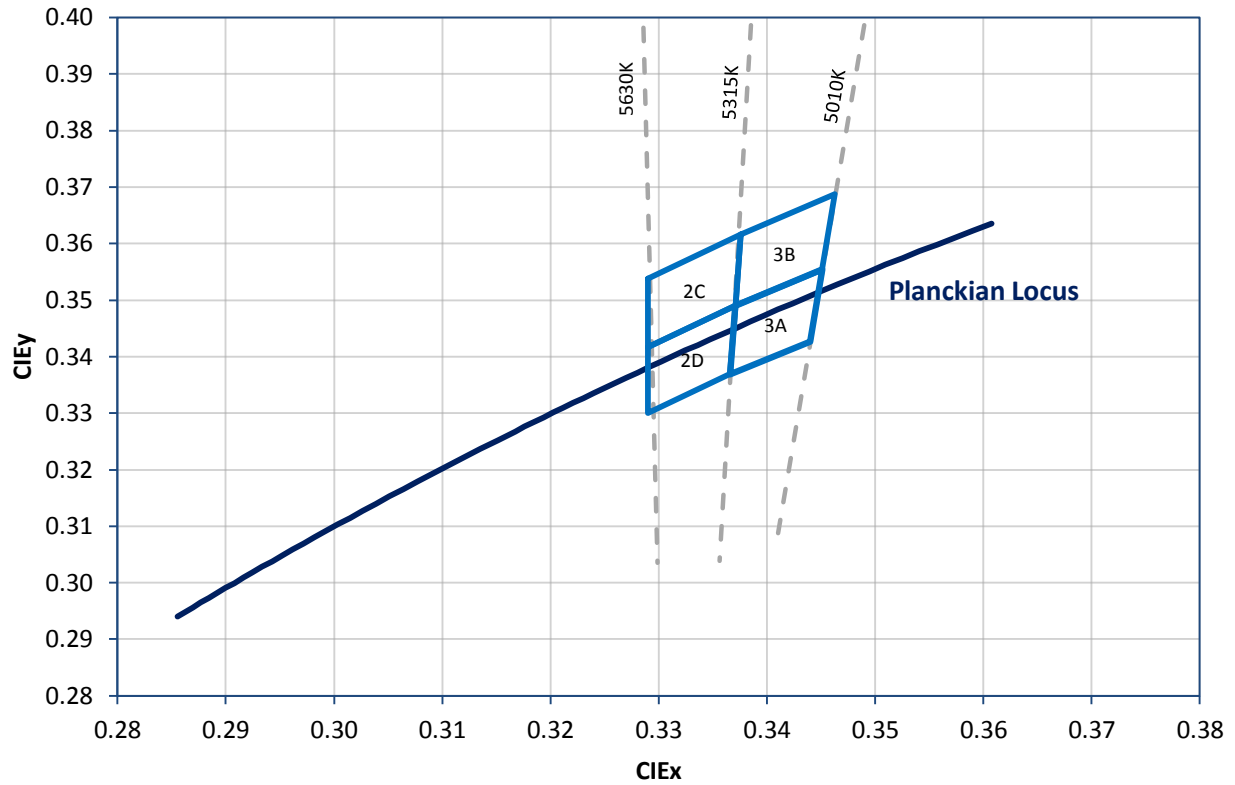

Standard Chromaticity Groups plotted on excerpt from the CIE 1931 (2°) x-y Chromaticity Diagram. Coordinates are listed below in the table.

## Studio White Bin Coordinates

Bin code	CIE <sub>x</sub>	CIE <sub>y</sub>	Bin code	CIE <sub>x</sub>	CIE <sub>y</sub>
2D	0.329	0.3417	2C	0.329	0.3538
	0.3371	0.349		0.3376	0.3616
	0.3366	0.3369		0.3371	0.349
	0.329	0.33		0.329	0.3417
3A	0.329	0.3417	0.329	0.3538	
	0.3371	0.349	0.3376	0.3616	
	0.3451	0.3554	0.3463	0.3687	
	0.344	0.3427	0.3451	0.3554	
	0.3366	0.3369	0.3371	0.349	
	0.3371	0.349	0.3376	0.3616	

## Luminous Flux Bins

Table 1:

<b>Bin Code</b>	<b>Minimum Luminous Flux (<math>\Phi_V</math>) @ <math>I_F = 700\text{mA}</math><sup>[1,2]</sup> (lm)</b>	<b>Maximum Luminous Flux (<math>\Phi_V</math>) @ <math>I_F = 700\text{mA}</math><sup>[1,2]</sup> (lm)</b>
Y	1,357	1,696
Z	1,696	2,120

Notes for Table 1:

1. Luminous flux performance guaranteed within published operating conditions. LED Engin maintains a tolerance of  $\pm 10\%$  on flux measurements.
2. Luminous Flux typical value is for all 12 LED dice operating concurrently at rated current.

## Forward Voltage Bins

Table 2:

<b>Bin Code</b>	<b>Minimum Forward Voltage (<math>V_F</math>) @ <math>I_F = 700\text{mA}</math><sup>[1,2]</sup> (V)</b>	<b>Maximum Forward Voltage (<math>V_F</math>) @ <math>I_F = 700\text{mA}</math><sup>[1,2]</sup> (V)</b>
0	36.0	43.2

Notes for Table 2:

1. LED Engin maintains a tolerance of  $\pm 0.48\text{V}$  for forward voltage measurements.
2. Forward Voltage is binned with 12 LED dice connected in series. The actual LED is configured with two strings of 6 dice in series.

## Absolute Maximum Ratings

Table 3:

Parameter	Symbol	Value	Unit
DC Forward Current at $T_{jmax}=130C^{[1]}$	$I_F$	1200	mA
DC Forward Current at $T_{jmax}=150C^{[1]}$	$I_F$	1000	mA
Peak Pulsed Forward Current <sup>[2]</sup>	$I_{FP}$	1500	mA
Reverse Voltage	$V_R$	See Note 3	V
Storage Temperature	$T_{stg}$	-40 ~ +150	°C
Junction Temperature	$T_J$	150	°C
Soldering Temperature <sup>[4]</sup>	$T_{sol}$	260	°C
Allowable Reflow Cycles		6	
ESD Sensitivity <sup>[5]</sup>		> 8,000 V HBM Class 3B JESD22-A114-D	

Notes for Table 3:

- Maximum DC forward current (per die) is determined by the overall thermal resistance and ambient temperature. Follow the curves in Figure 10 for current derating.
- Pulse forward current conditions: Pulse Width  $\leq 10\text{msec}$  and Duty cycle  $\leq 10\%$ .
- LEDs are not designed to be reverse biased.
- Solder conditions per JEDEC 020D. See Reflow Soldering Profile Figure 5.
- LED Engin recommends taking reasonable precautions towards possible ESD damages and handling the LZ4-00SW00 in an electrostatic protected area (EPA). An EPA may be adequately protected by ESD controls as outlined in ANSI/ESD S6.1.

## Optical Characteristics @ $T_C = 25^\circ\text{C}$

Table 4:

Parameter	Symbol	Typical	Unit
Luminous Flux (@ $I_F = 700\text{mA}$ ) <sup>[1]</sup>	$\Phi_V$	1900	lm
Luminous Flux (@ $I_F = 1000\text{mA}$ ) <sup>[1]</sup>	$\Phi_V$	2450	lm
Luminous Efficacy (@ $I_F = 350\text{mA}$ )		89	lm/W
Correlated Color Temperature	CCT	5300	K
Color Rendering Index (CRI)	$R_a$	88	
Viewing Angle <sup>[2]</sup>	$2\theta_{1/2}$	110	Degrees

Notes for Table 4:

- Luminous flux typical value is for all 12 LED dice operating concurrently at rated current.
- Viewing Angle is the off-axis angle from emitter centerline where the luminous intensity is  $\frac{1}{2}$  of the peak value.

## Electrical Characteristics @ $T_C = 25^\circ\text{C}$

Table 5:

Parameter	Symbol	Typical	Unit
Forward Voltage (@ $I_F = 700\text{mA}$ ) <sup>[1]</sup>	$V_F$	38.8	V
Forward Voltage (@ $I_F = 1000\text{mA}$ ) <sup>[1]</sup>	$V_F$	40.0	V
Temperature Coefficient of Forward Voltage <sup>[1]</sup>	$\Delta V_F/\Delta T_J$	-24.0	mV/°C
Thermal Resistance (Junction to Case)	$R\theta_{J-C}$	0.7	°C/W

Notes for Table 5:

- Forward Voltage is binned with 12 LED dice connected in series. The actual LED is configured with two strings of 6 dice in series.

## IPC/JEDEC Moisture Sensitivity Level

Table 6 - IPC/JEDEC J-STD-20.1 MSL Classification:

Level	Soak Requirements					
	Floor Life		Standard		Accelerated	
	Time	Conditions	Time (hrs)	Conditions	Time (hrs)	Conditions
1	unlimited	≤ 30°C/ 85% RH	168 +5/-0	85°C/ 85% RH	n/a	n/a

Notes for Table 6:

- The standard soak time includes a default value of 24 hours for semiconductor manufacturer's exposure time (MET) between bake and bag and includes the maximum time allowed out of the bag at the distributor's facility.

## Average Lumen Maintenance Projections

Lumen maintenance generally describes the ability of a lamp to retain its output over time. The useful lifetime for solid state lighting devices (Power LEDs) is also defined as Lumen Maintenance, with the percentage of the original light output remaining at a defined time period.

Based on long-term WHTOL testing, LED Engin projects that the LZC Series will deliver, on average, 70% Lumen Maintenance at 70,000 hours of operation at a forward current of 700 mA per die. This projection is based on constant current operation with junction temperature maintained at or below 110°C.

## Mechanical Dimensions (mm)

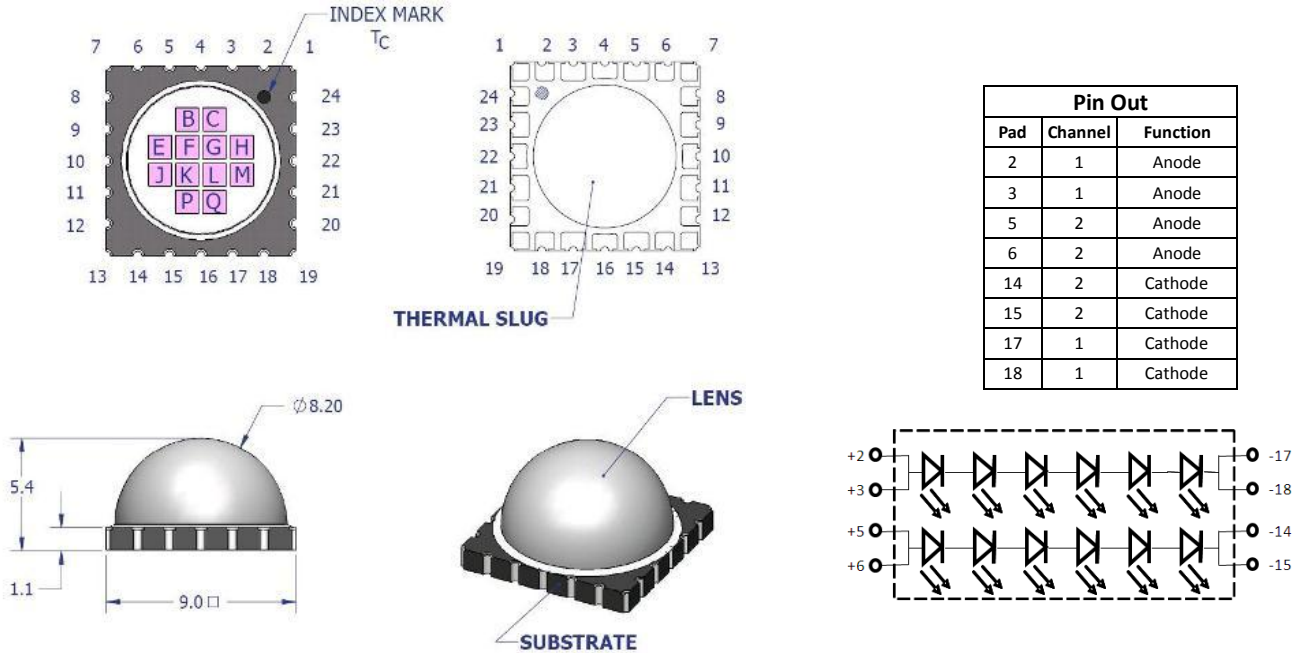

Figure 1: Package outline drawing.

### Notes for Figure 1:

- LZC-00SW00 is compatible with MCPCB designed for other LZC White emitters (i.e. LZC-00xW00) when emitter is rotated 180 degree with respect to the LZC-xW00 position on the MCPCB.
- Index mark, Tc indicates case temperature measurement point.
- Unless otherwise noted, the tolerance =  $\pm 0.20$  mm.
- Thermal contact pad is electrically neutral.

## Recommended Solder Pad Layout (mm)

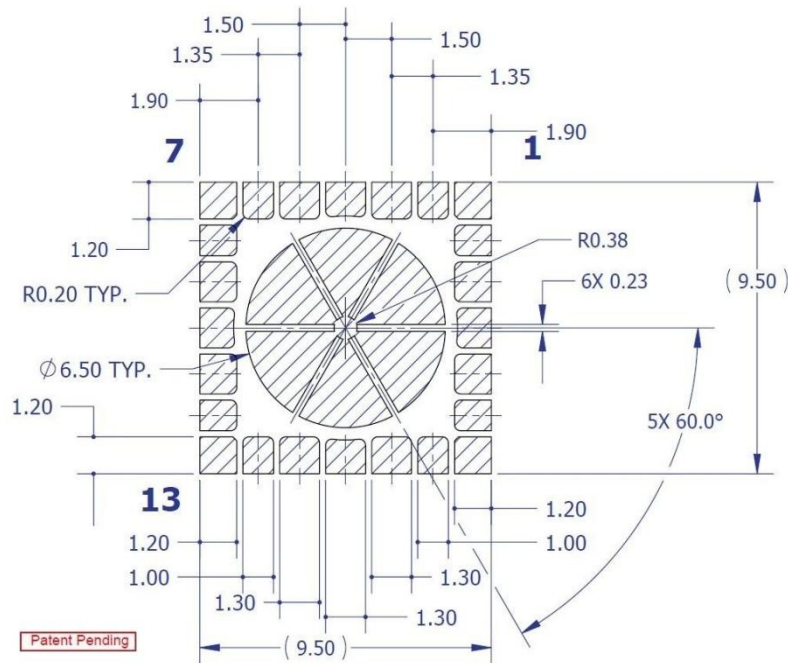

Figure 2a: Recommended solder pad layout for anode, cathode, and thermal pad.

### Note for Figure 2a:

- Unless otherwise noted, the tolerance =  $\pm 0.20$  mm.



### Typical Radiation Pattern

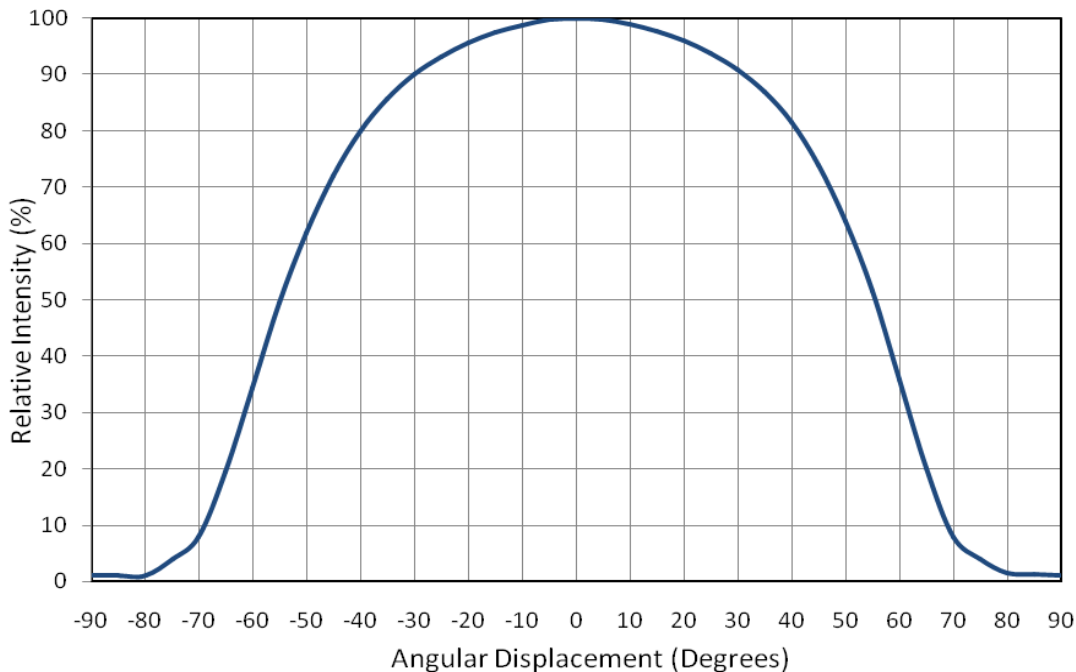

Figure 4: Typical representative spatial radiation pattern.

### Typical Relative Spectral Power Distribution

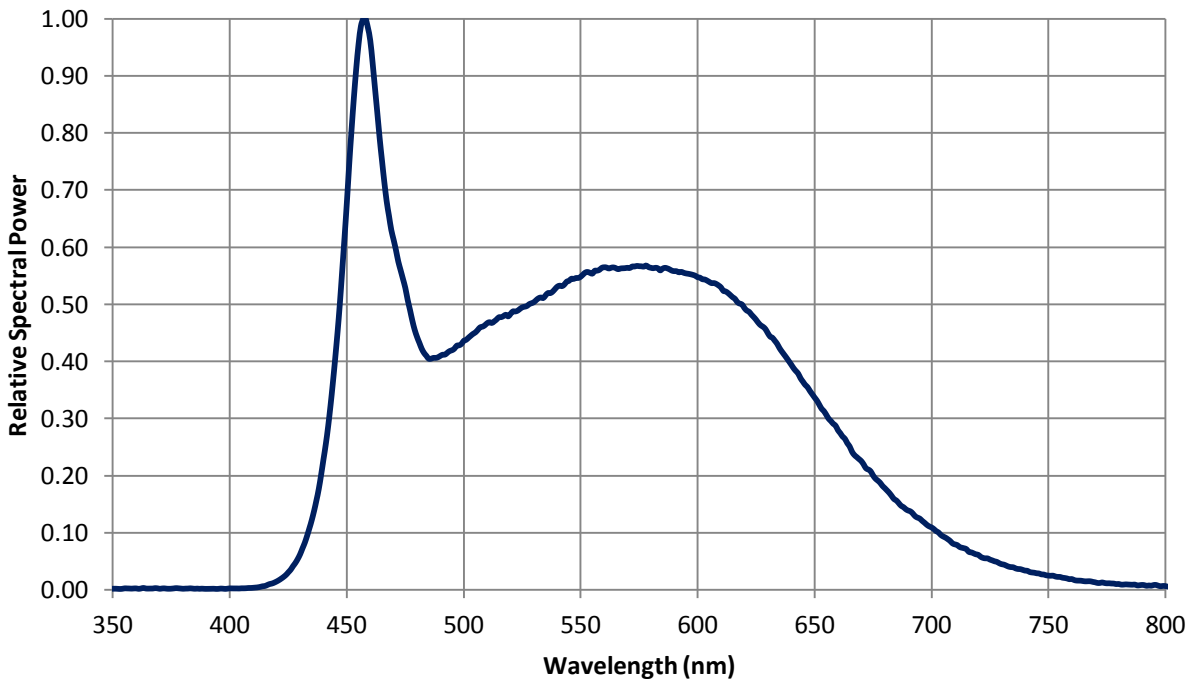

Figure 5: Typical relative spectral power vs. wavelength @ T<sub>c</sub> = 25°C.

### Typical Chromaticity Coordinate Shift over Temperature

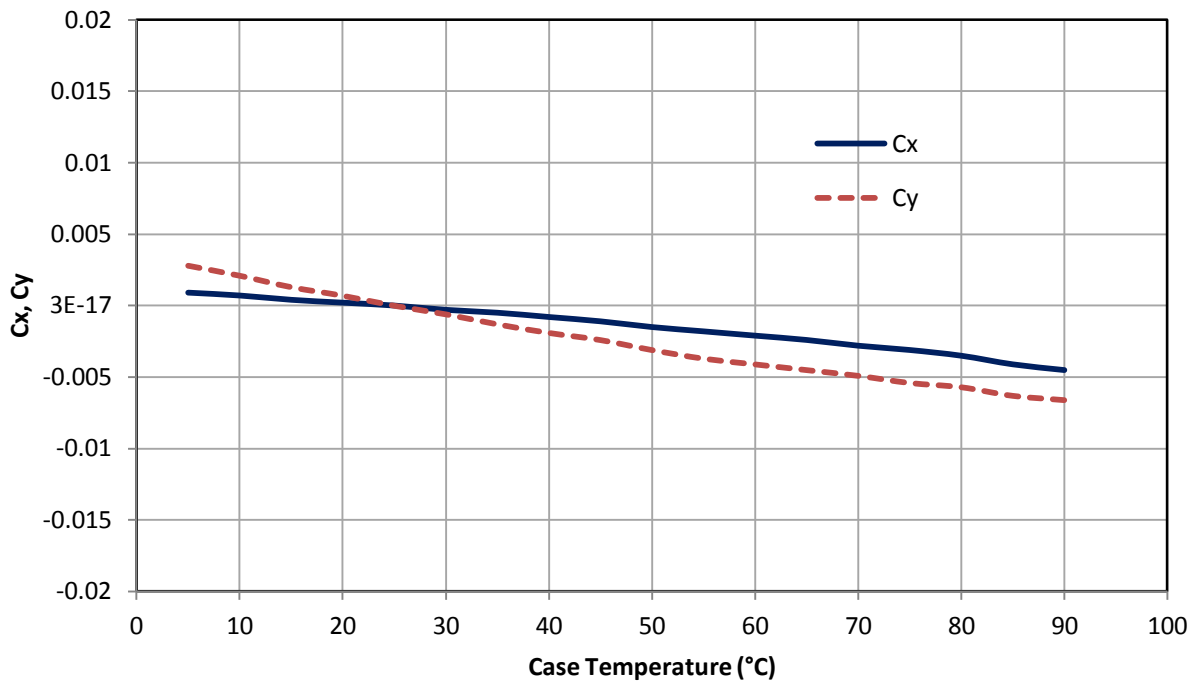

Figure 6: Typical chromaticity coordinate shift vs. Case temperature.

### Typical Relative Light Output

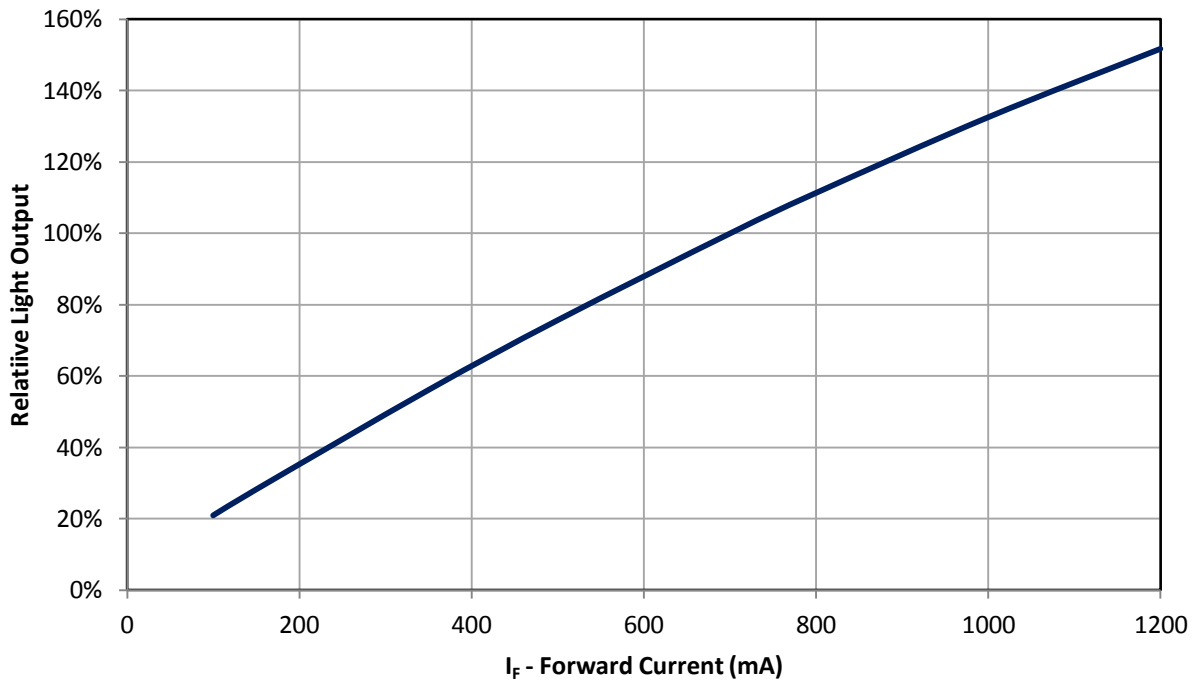

Figure 7: Typical relative light output vs. forward current @ T<sub>c</sub> = 25°C.

Notes for Figure 7:

1. Luminous Flux typical value is for all 12 LED dice operating concurrently at rated current.

### Typical Relative Light Output over Temperature

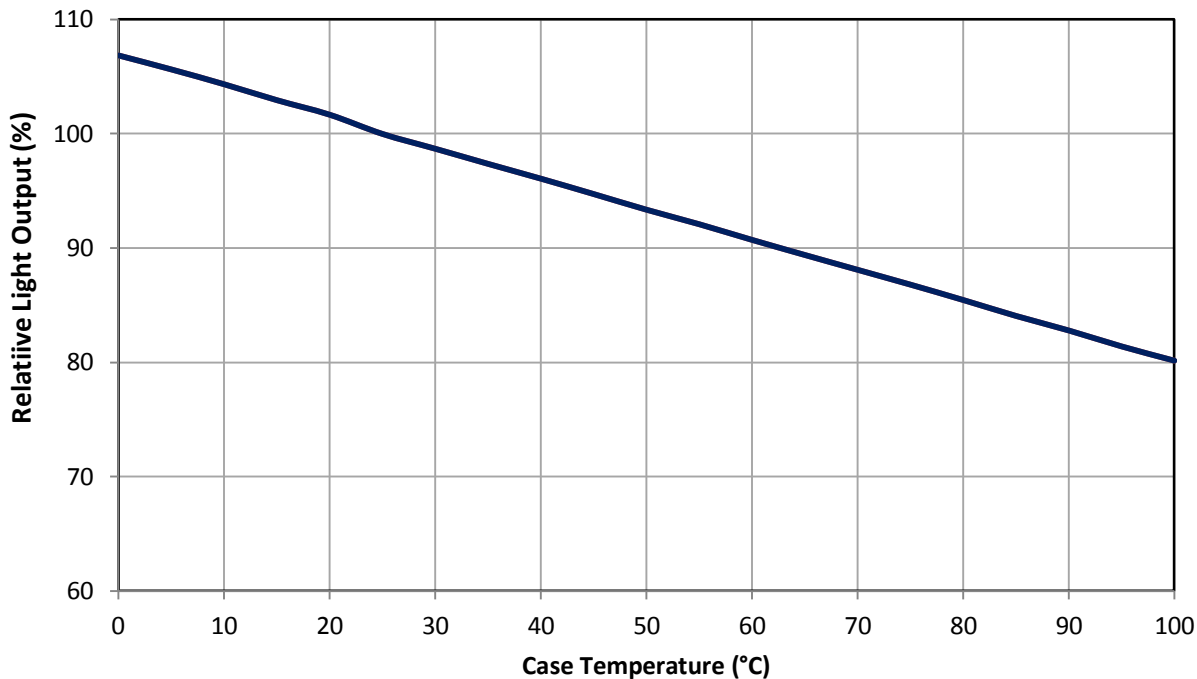

Figure 8: Typical relative light output vs. case temperature.

Notes for Figure 8:

1. Luminous Flux typical value is for all 12 LED dice operating concurrently at rated current.

### Typical Forward Current Characteristics

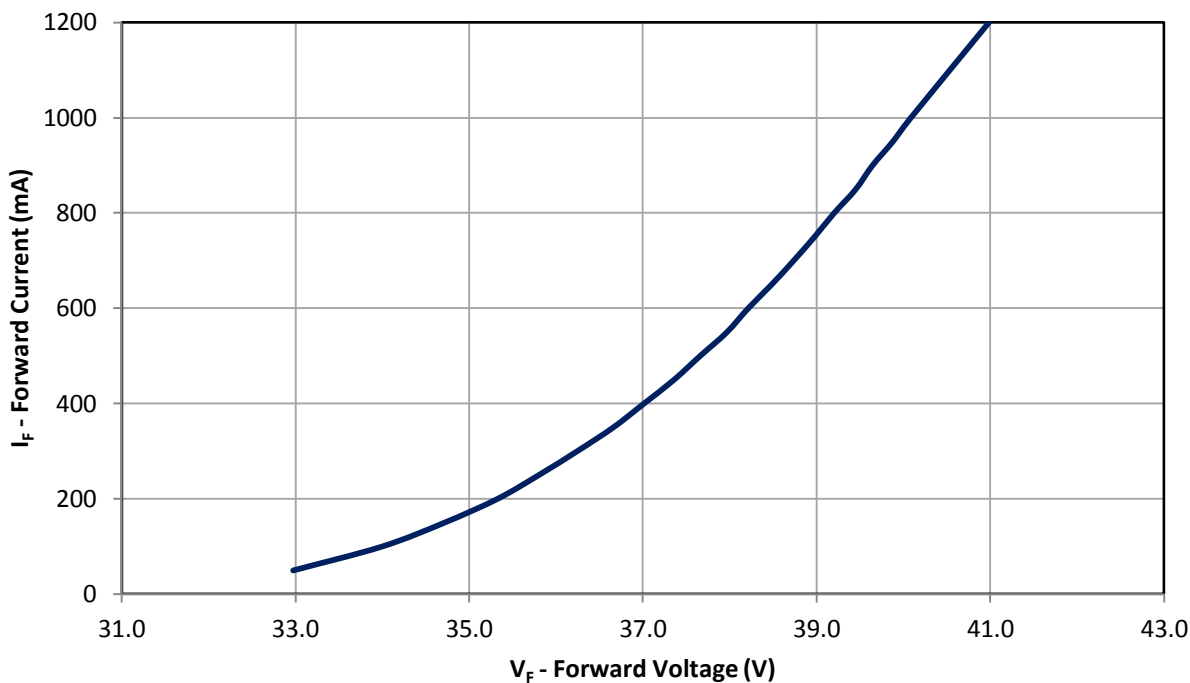

Figure 9: Typical forward current vs. forward voltage @ T<sub>C</sub> = at 25°C.

Note for Figure 9:

1. Forward Voltage assumes 12 LED dice connected in series. The actual LED is configured with two strings of 6 dice in series.

## Current De-rating

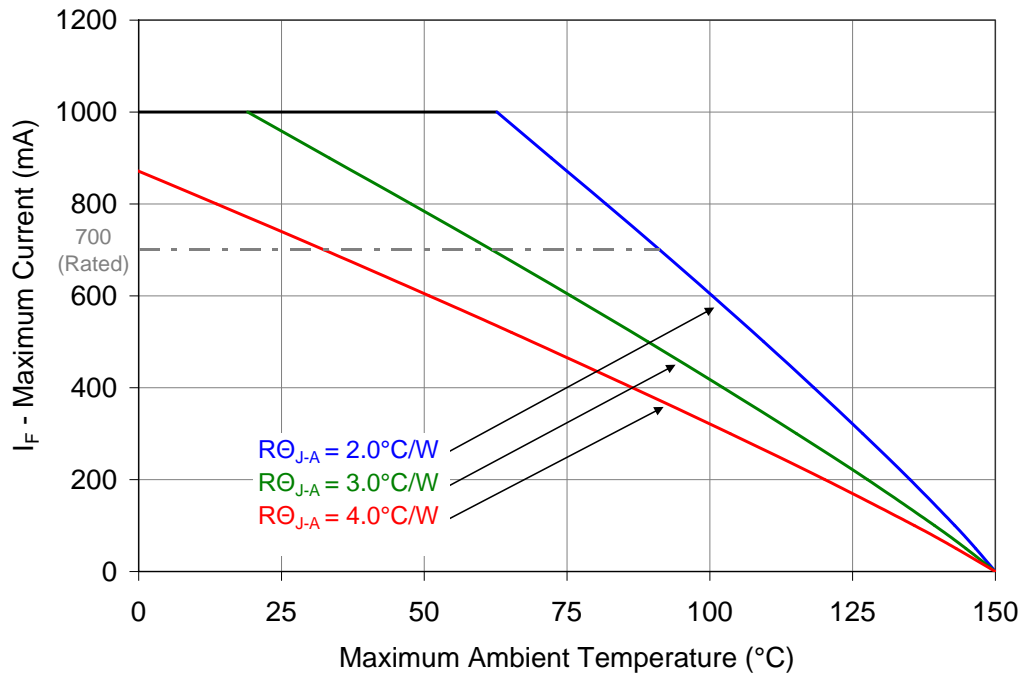

Figure 10: Maximum forward current vs. ambient temperature based on  $T_{J(\text{MAX})} = 150^{\circ}\text{C}$ .

### Notes for Figure 10:

1. Maximum current assumes that all LED dice are operating concurrently at the same current.
2.  $R_{\theta_{J-C}}$  [Junction to Case Thermal Resistance] for the LZC-00xx00 is typically  $0.7^{\circ}\text{C/W}$ .
3.  $R_{\theta_{J-A}}$  [Junction to Ambient Thermal Resistance] =  $R_{\theta_{J-C}} + R_{\theta_{C-A}}$  [Case to Ambient Thermal Resistance].

### Emitter Tape and Reel Specifications (mm)

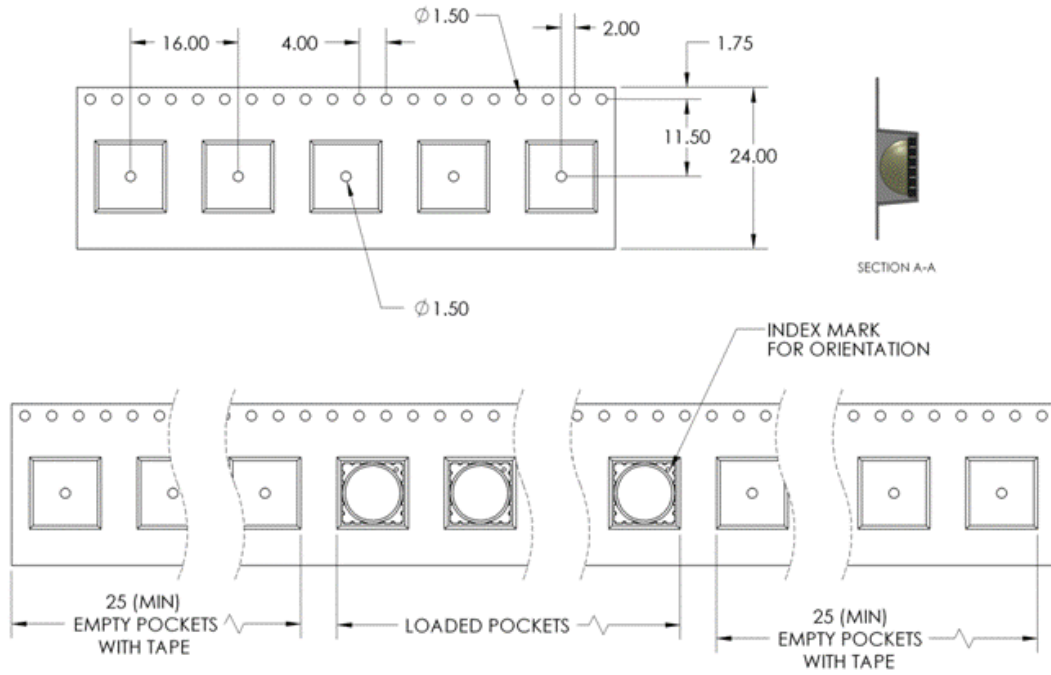

Figure 11: Emitter carrier tape specifications (mm).

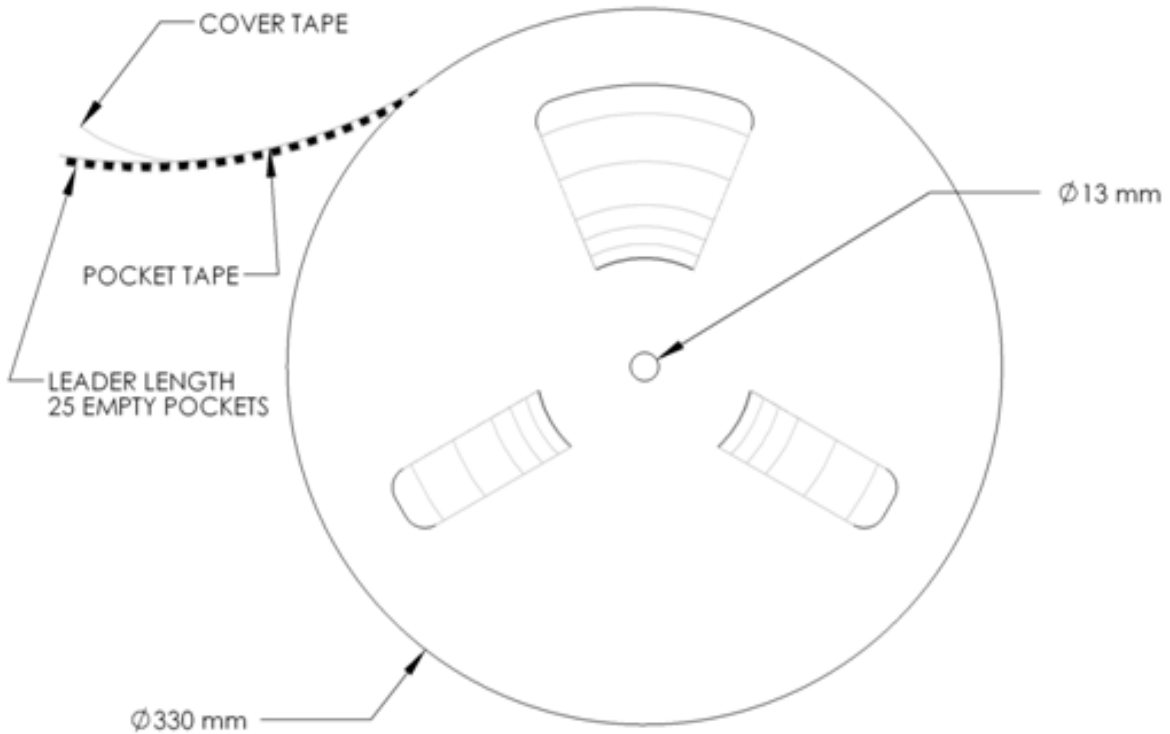

Figure 12: Emitter Reel specifications (mm).

# LZC MCPCB Family

Part number	Type of MCPCB	Diameter (mm)	Emitter + MCPCB Thermal Resistance (°C/W)	Typical $V_f$ (V)	Typical $I_f$ (mA)
LZC-7xxxxx	1-channel	28.3	$0.7 + 0.6 = 1.3$	38.8	700
LZC-Cxxxxx	2-channel	28.3	$0.7 + 0.6 = 1.3$	19.4	2 x 700
LZC-ExxxT1	1-channel (1 x 12 string)	49.5	$0.7 + 0.6 = 1.3$	38.8	700
LZC-FxxxT1	1-channel (2 x 6 strings)	49.5	$0.7 + 0.6 = 1.3$	19.4	1400

## Mechanical Mounting of MCPCB

- MCPCB bending should be avoided as it will cause mechanical stress on the emitter, which could lead to substrate cracking and subsequently LED dies cracking.
- To avoid MCPCB bending:
  - Special attention needs to be paid to the flatness of the heat sink surface and the torque on the screws.
  - Care must be taken when securing the board to the heat sink. This can be done by tightening three M3 screws (or #4-40) in steps and not all the way through at once. Using fewer than three screws will increase the likelihood of board bending.
  - It is recommended to always use plastics washers in combinations with the three screws.
  - If non-taped holes are used with self-tapping screws, it is advised to back out the screws slightly after tightening (with controlled torque) and then re-tighten the screws again.

## Thermal interface material

- To properly transfer heat from LED emitter to heat sink, a thermally conductive material is required when mounting the MCPCB on to the heat sink.
- There are several varieties of such material: thermal paste, thermal pads, phase change materials and thermal epoxies. An example of such material is Electrolube EHTC.
- It is critical to verify the material's thermal resistance to be sufficient for the selected emitter and its operating conditions.

## Wire soldering

- To ease soldering wire to MCPCB process, it is advised to preheat the MCPCB on a hot plate of 125-150°C. Subsequently, apply the solder and additional heat from the solder iron will initiate a good solder reflow. It is recommended to use a solder iron of more than 60W.
- It is advised to use lead-free, no-clean solder. For example: SN-96.5 AG-3.0 CU 0.5 #58/275 from Kester (pn: 24-7068-7601)

# LZC-7xxxxx

## 1-Channel MCPCB Mechanical Dimensions (mm)

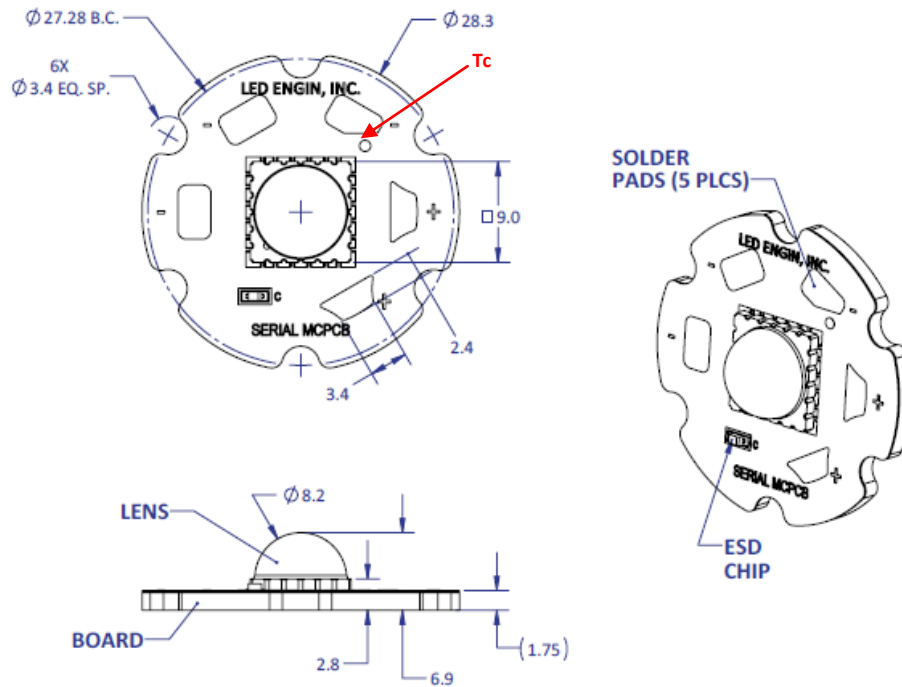

**Notes:**

- Unless otherwise noted, the tolerance =  $\pm 0.2$  mm.
- Slots in MCPCB are for M3 or #4-40 mounting screws.
- LED Engin recommends plastic washers to electrically insulate screws from solder pads and electrical traces.
- Electrical connection pads on MCPCB are labeled “+” for Anode and “-” for Cathode.
- LED Engin recommends using thermal interface material when attaching the MCPCB to a heatsink.
- The thermal resistance of the MCPCB is:  $R_{\theta C-B}$  0.6°C/W

## Components used

MCPCB: HT04503 (Bergquist)  
 ESD chips: BZX585-C51 (NPX, for 12 LED dies in series)

Pad layout			
Ch.	MCPCB Pad	String/die	Function
1	+	1/BCEFGHJ	Anode +
	-	KLMPQ	Cathode -

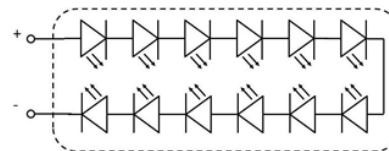

# LZC-Cxxxxx

## 2 channel, Star MCPCB (2x6) Dimensions (mm)

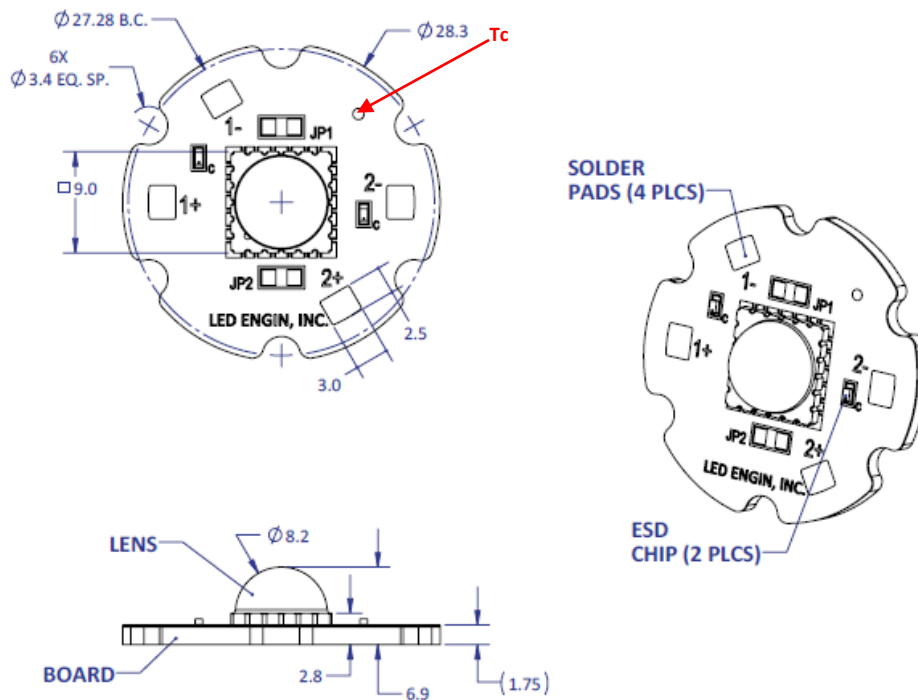

### Notes:

- Unless otherwise noted, the tolerance =  $\pm 0.2$  mm.
- Slots in MCPCB are for M3 or #4-40 mounting screws.
- LED Engin recommends plastic washers to electrically insulate screws from solder pads and electrical traces.
- Electrical connection pads on MCPCB are labeled "+" for Anode and "-" for Cathode.
- LED Engin recommends thermal interface material when attaching the MCPCB to a heatsink.
- The thermal resistance of the MCPCB is: R $\theta$ C-B 0.6°C/W

## Components used

MCPCB: HT04503 (Bergquist)  
 ESD chips: BZT52C36LP (NPX, for 6 LED dies in series)

Pad layout			
Ch.	MCPCB Pad	String/die	Function
1	1+	1/JKLMPQ	Anode +
	1-		Cathode -
2	2+	2/BCEFGH	Anode +
	2-		Cathode -

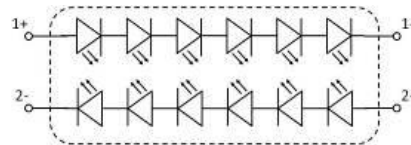

# LZC-ExxxT1

## 1-Channel (1x12 string) Connectorized MCPCB with Thermistor Mechanical Dimensions (mm)

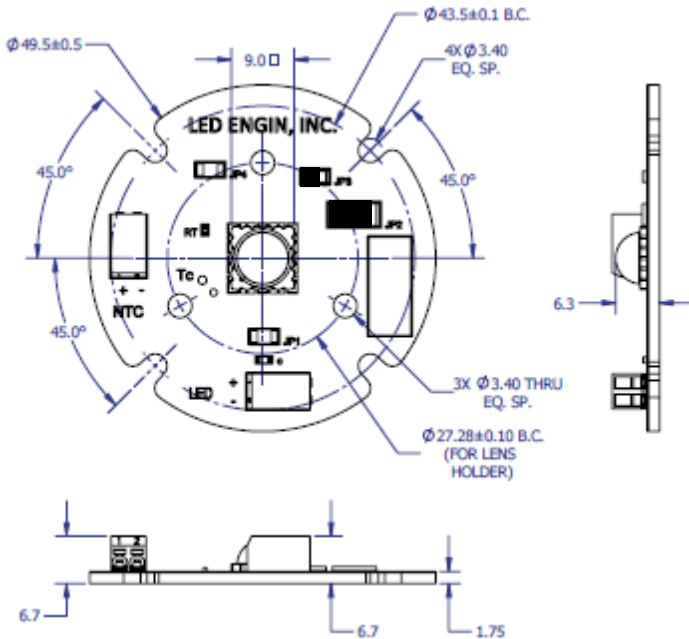

Note for Figure 1:

- Unless otherwise noted, the tolerance =  $\pm 0.2$  mm, angle =  $\pm 1^\circ$
- Slots in MCPCB are for M3 or #4-40 mounting screws. Maximum torque should not exceed 1N-m ( 8.9 lbf-in)
- LED Engin recommends plastic washers to electrically insulate screws from solder pads and electrical traces.
- LED Engin recommends using thermally interface material when attaching the MCPCB to a heatsink
- For the connectors it is recommended to use solid wires with gauge size, 18, 20 or 22 AWG. It is recommended to strip the insulation of the wires to a length of 4-5mm. When stranded wires are used it is recommended to twist the strands at the end of the wire and use wire extraction toll to insert the wires.
- The thermal resistance of the MCPCB is:  $R_{\theta C-B} 0.6^\circ\text{C/W}$

## Components used

MCPCB:	HT04503	(Bergquist)
ESD chips:	BZX585-C51	(NXP, for 12 LED dies in series)
Thermistor:	NCP15WF104F03RC	(Murata, 100kOhm for the LZx-xxxxT1, please see <a href="http://www.murata.com">www.murata.com</a> for details on calculating the thermistor temperature)
Connectors:	00-9276-002-0-21-1-06	(AVX, poke-home)

Ch.	Pad	Emitter pin	Function
1	LED1+	14, 15	Anode
	LED1-	2, 3	Cathode
T	NTC	N/A	N/A
	NTC	N/A	N/A

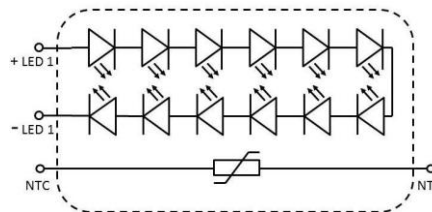

# LZC-FxxxT1

## 1-Channel (2x6 strings) Connectorized MCPCB with Thermistor Mechanical Dimensions (mm)

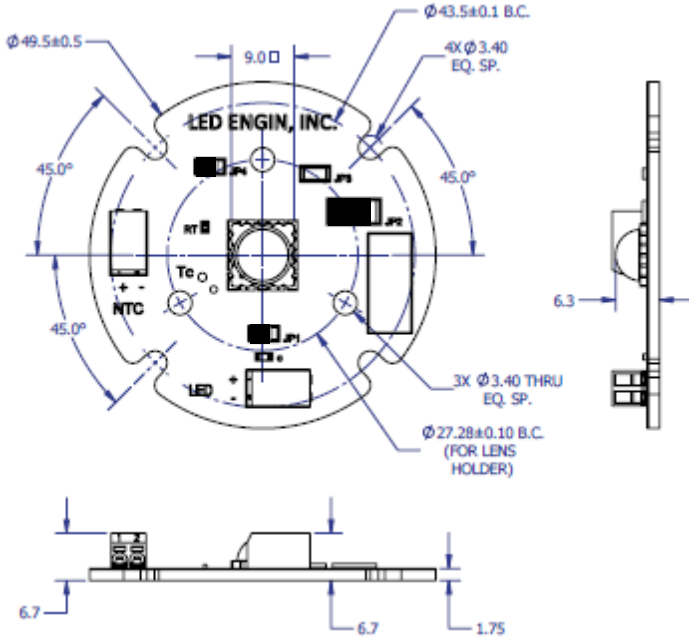

Note for Figure 1:

- Unless otherwise noted, the tolerance =  $\pm 0.2 \text{ mm}$ , angle =  $\pm 1^\circ$
- Slots in MCPCB are for M3 or #4-40 mounting screws. Maximum torque should not exceed 1N-m ( 8.9 lbf-in)
- LED Engin recommends plastic washers to electrically insulate screws from solder pads and electrical traces.
- LED Engin recommends using thermally interface material when attaching the MCPCB to a heatsink
- For the connectors it is recommended to use solid wires with gauge size, 18, 20 or 22 AWG. It is recommended to strip the insulation of the wires to a length of 4-5mm. When stranded wires are used it is recommended to twist the strands at the end of the wire and use wire extraction toll to insert the wires.
- The thermal resistance of the MCPCB is:  $\theta_{\text{JC-B}} 0.6^\circ\text{C/W}$

## Components used

MCPCB:	HT04503	(Bergquist)
ESD chips:	BZT52C36LP	(NXP, for 6 LED dies in series)
Thermistor:	NCP15WF104F03RC	(Murata, 100kOhm for the LZx-xxxxT1, please see <a href="http://www.murata.com">www.murata.com</a> for details on calculating the thermistor temperature)
Connectors:	00-9276-002-0-21-1-06	(AVX, poke-home)

Ch.	Pad	Emitter pin	Function
1	LED1+	14, 15, 17, 18	Anode
	LED1-	2, 3, 5, 6	Cathode
T	NTC	N/A	N/A
	NTC	N/A	N/A

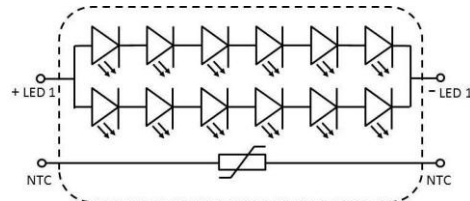

## Appendix: Wire Insertion and Extraction Instructions AVX poke-home

For the AVX poke-home it is recommended to use solid wires with gauge size, 18, 20 or 22 AWG, but stranded wire can be used as well. Push the wire in and then give slight tug on the wire to confirm that it is properly engaged.

### Wire Insertion Solid conductor

- Strip insulation length 4-5mm
- Insert into appropriate hole to a stop
- Inserted wire will be retained by contact

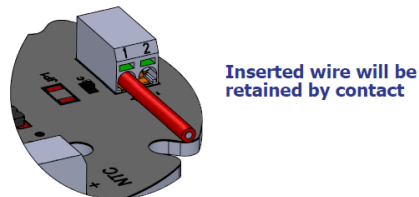
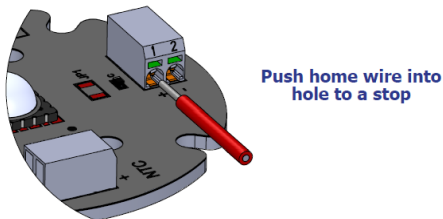

### Wire Insertion Stranded wire conductor

- Twist strands together
- Insert tool into contact operation slot
- Insert wire
- Remove tool

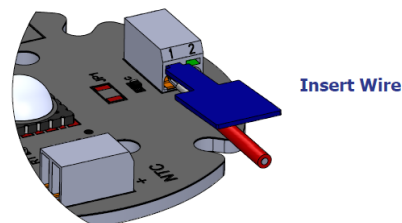
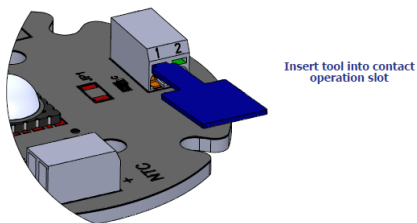
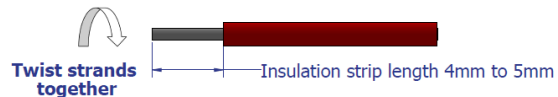

### Wire extraction

- Insert tool into contact
- Extract wire
- Remove tool

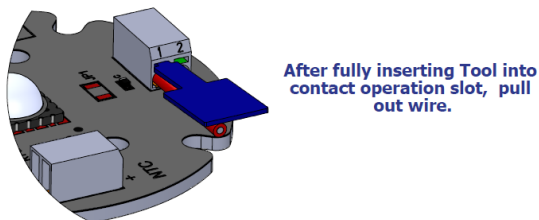

### Extraction Tool References:

Thin Blade Wire Extraction Tool: AVX P/N - 0692-7670-0101-000  
 Miniature Precision Screw Driver, 0.047" Tip Width

## Company Information

LED Engin, based in California's Silicon Valley, develops, manufactures, and sells advanced LED emitters, optics and light engines to create uncompromised lighting experiences for a wide range of entertainment, architectural, general lighting and specialty applications. LuxiGen™ multi-die emitter and secondary lens combinations reliably deliver industry-leading flux density, upwards of 5000 quality lumens to a target, in a wide spectrum of colors including whites, tunable whites, multi-color and UV LEDs in a unique patented compact ceramic package. Our LuxiTune™ series of tunable white lighting modules leverage our LuxiGen emitters and lenses to deliver quality, control, freedom and high density tunable white light solutions for a broad range of new recessed and downlighting applications. The small size, yet remarkably powerful beam output and superior in-source color mixing, allows for a previously unobtainable freedom of design wherever high-flux density, directional light is required.

LED Engin is committed to providing products that conserve natural resources and reduce greenhouse emissions.

LED Engin reserves the right to make changes to improve performance without notice.

Please contact [sales@ledengin.com](mailto:sales@ledengin.com) or (408) 922-7200 for more information.