

# DATA SHEET

Part No.	AN26025A
Package Code No.	ALGA005-W-0609ANA

---

**Contents**

■ Overview .....	3
■ Features .....	3
■ Applications .....	3
■ Package .....	3
■ Type .....	3
■ Application Circuit Example (Block Diagram) .....	4
■ Pin Descriptions .....	5
■ Absolute Maximum Ratings .....	6
■ Operating Supply Voltage Range .....	6
■ Allowable Voltage Range .....	7
■ Electrical Characteristics .....	8
■ Electrical Characteristics (Reference values for design) .....	10
■ Control Pin Mode Table .....	12
■ Truth Table .....	12
■ Technical Data .....	13
• I/O block circuit diagrams and pin function descriptions .....	13
• $P_D - T_a$ diagram .....	14
■ Usage Note .....	15

# AN26025A

## Single Band LNA-IC for 5 GHz Band Applications

### ■ Overview

- AN26025A is a single band LNA (Low Noise Amplifier)-IC for 5 GHz Band applications.
- Realizing high performance by using 0.18  $\mu\text{m}$  SiGeC Bi-CMOS process ( $f_T = 90 \text{ GHz}$ ,  $f_{\text{max}} = 140 \text{ GHz}$ ).
- High/Low Gain-mode is changeable, controlled by integrated CMOS logic circuit.
- Achieving miniaturization by using small size Wafer Level Chip Size Package (WLCSP).

### ■ Features

- |                           |                        |                  |
|---------------------------|------------------------|------------------|
| • Low voltage operation   | +3.3 V typ.            |                  |
| • Low current consumption | 7.5 mA typ.            | (High-Gain mode) |
|                           | 7.5 $\mu\text{A}$ typ. | (Low-Gain mode)  |
| • High gain               | 14 dB typ.             | (High-Gain mode) |
| • Low noise figure        | 1.65 dB typ.           | (High-Gain mode) |
| • Low distortion          | +5 dBm typ.            | (High-Gain mode) |
| • Small package (WLCSP)   |                        |                  |

### ■ Applications

- 5 GHz Single Band LNA

### ■ Package

- 5 pin Wafer level chip size package (WLCSP)  
Size : 0.86 mm  $\times$  0.56 mm (0.3 mm pitch)

### ■ Type

- Bi-CMOS IC

■ Application Circuit Example (Block Diagram)

(Top View)

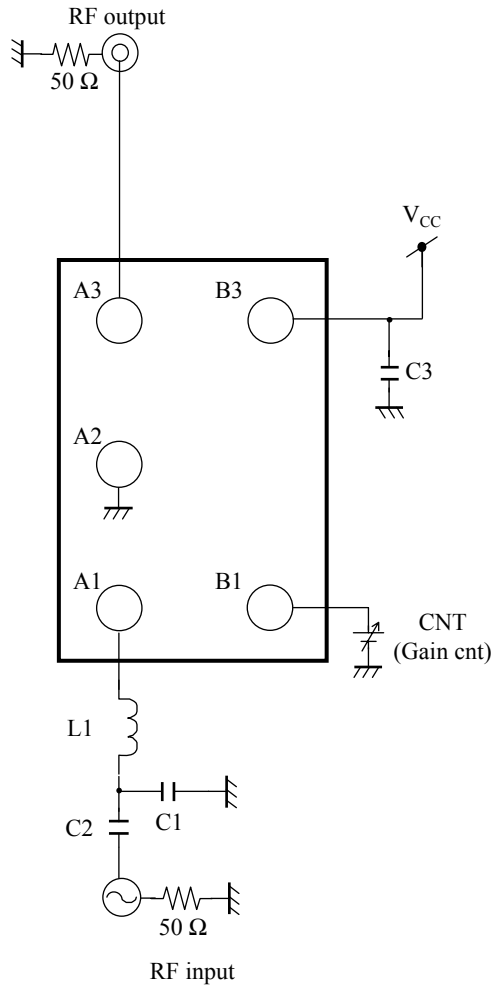

• External Components

Components	Size	Value	Part Number	Vendor
L1	0603	1.0 nH	LQP03TN1N0B02	Murata
C1	0603	0.5 pF	GRM0334C1HR50WD01D	Murata
C2	0603	1 000 pF	GRM033B11C102KD01	Murata
C3	0603	100 000 pF	GRM33B30J104KE18	Murata

- Notes)
- This application circuit is an example. The operation of mass production set is not guaranteed. You should perform enough evaluation and verification on the design of mass production set. You are fully responsible for the incorporation of the above application circuit and information in the design of your equipment.
  - This block diagram is for explaining functions. The part of the block diagram may be omitted, or it may be simplified.

## ■ Pin Descriptions

Pin No.	Pin name	Type	Description
A1	IN	Input	RF input
A2	GND	Ground	GND
A3	OUT	Output	RF output
B1	CNT	Input	High-Gain/Low-Gain switch
B3	VCC	Power Supply	V <sub>CC</sub>

### ■ Absolute Maximum Ratings

Note) Absolute maximum ratings are limit values which do not result in damages to this IC, and IC operation is not guaranteed at these limit values.

A No.	Parameter	Symbol	Rating	Unit	Notes
1	Supply voltage	$V_{CC}$	3.7	V	*1
2	Supply current	$I_{CC}$	18	mA	—
3	Power dissipation	$P_D$	46.7	mW	*2
4	Operating ambient temperature	$T_{opr}$	−40 to +85	°C	*3
5	Storage temperature	$T_{stg}$	−55 to +150	°C	*3

Notes) \*1 : The values under the condition not exceeding the above absolute maximum ratings and the power dissipation.

\*2 : The power dissipation shown is the value at  $T_a = 85^\circ\text{C}$  for the independent (unmounted) IC package with a heat sink.

When using this IC, refer to •  $P_D - T_a$  diagram in the ■ Technical Data and design the heat radiation with sufficient margin so that the allowable value might not be exceeded based on the conditions of power supply voltage, load, and ambient temperature.

\*3 : Except for the power dissipation, operating ambient temperature, and storage temperature, all ratings are for  $T_a = 25^\circ\text{C}$ .

### ■ Operating supply voltage range

Parameter	Symbol	Range	Unit	Notes
Supply voltage range	$V_{CC}$	2.7 to 3.6	V	*

Note) \* : The values under the condition not exceeding the above absolute maximum ratings and the power dissipation.

**■ Allowable Voltage Range**

- Notes)
- Allowable current and voltage ranges are limit ranges which do not result in damages to this IC, and IC operation is not guaranteed within these limit ranges.
  - Voltage values, unless otherwise specified, are with respect to GND.
  - Do not apply external currents or voltages to any pin not specifically mentioned.
  - For the circuit currents, "+" denotes current flowing into the IC, and "-" denotes current flowing out of the IC.

Pin No.	Pin name	Rating	Unit	Note
A1	IN	—	V	*1
A3	OUT	- 0.3 to $V_{CC}$	V	—
B1	CNT	- 0.3 to $V_{CC}$	V	—

Note) \*1 : RF signal input pin. Do not apply DC current. Do not apply more than 0 dBm to RF input.

### ■ Electrical Characteristics at $V_{CC} = 3.3\text{ V}$

Note)  $T_a = 25^\circ\text{C} \pm 2^\circ\text{C}$  unless otherwise specified.

$T_a = 25^\circ\text{C} \pm 2^\circ\text{C}$ ,  $f_{RX} = 5.50\text{GHz}$ ,  $PRX = -30\text{ dBm}$ , CW unless otherwise specified.

B No.	Parameter	Symbol	Conditions	Limits			Unit	Note
				Min	Typ	Max		
DC electrical characteristics								
DC-1	Supply current HG	$I_{CCH}$	$V_{CC}$ current at High-Gain mode No input signal	—	7.5	10	mA	—
DC-2	Supply current LG	$I_{CCL}$	$V_{CC}$ current at Low-Gain mode No input signal	—	7.5	15	$\mu\text{A}$	—
DC-3	Input voltage (High-Gain mode)	$V_{IH}$	—	1.48	—	3.6	V	—
DC-4	Input voltage (Low-Gain mode)	$V_{IL}$	—	0	—	0.6	V	—
DC-5	SW current (High)	$I_{IH}$	Current at CNT pin $V_{IH} = V_{CC}$	—	19	30	$\mu\text{A}$	—

■ Electrical Characteristics (continued) at  $V_{CC} = 3.3\text{ V}$

Note)  $T_a = 25^\circ\text{C} \pm 2^\circ\text{C}$ ,  $f_{RX} = 5.50\text{ GHz}$ ,  $PRX = -30\text{ dBm}$ , CW unless otherwise specified.

B No.	Parameter	Symbol	Conditions	Limits			Unit	Note
				Min	Typ	Max		
AC electrical characteristics								
A-1	Power Gain HG	GHS	High-Gain mode	12.0	14.0	16.0	dB	—
A-2	Power Gain LG	GLS	Low-Gain mode	-12.6	-10.5	-8.4	dB	—

### ■ Electrical Characteristics (Reference values for design) at $V_{CC} = 3.3\text{ V}$

Notes)  $T_a = 25^\circ\text{C} \pm 2^\circ\text{C}$ ,  $f_{RX} = 5.15\text{ GHz}, 5.5\text{ GHz}, 5.85\text{ GHz}$ ,  $PRX = -30\text{ dBm}$ , CW unless otherwise specified.

The characteristics listed below are reference values derived from the design of the IC and are not guaranteed by inspection.

If a problem does occur related to these characteristics, we will respond in good faith to user concerns.

B No.	Parameter	Symbol	Conditions	Reference values			Unit	Note
				Min	Typ	Max		
AC electrical characteristics								
C-1	Power Gain HG	GHa	High-Gain mode	11.5	14	16.5	dB	—
C-2	Power Gain LG	GLa	Low-Gain mode	-13	-10.5	-8	dB	—
C-3	Noise Figure HG	NFHa	High-Gain mode	—	1.9	2.25	dB	*1
C-4	Noise Figure LG	NFLa	Low-Gain mode	—	10.5	13.5	dB	*1
C-5	IIP3 -10 MHz offset HG	IIP3H1a	High-Gain mode $f1 = f_{RXa} - 10\text{ MHz}$ $f2 = f_{RXa} - 20\text{ MHz}$ Input 2 signals ( $f1, f2$ )	-1	5	—	dBm	—
C-6	IIP3 +10 MHz offset HG	IIP3H2a	High-Gain mode $f1 = f_{RXa} + 10\text{ MHz}$ $f2 = f_{RXa} + 20\text{ MHz}$ Input 2 signals ( $f1, f2$ )	-1	4	—	dBm	—
C-7	Input P1dB HG	IP1dBHa	High-Gain mode	-13.5	-9	—	dBm	—
C-8	IIP3 +100 kHz offset LG	IIP3La	Low-Gain mode $f1 = f_{RXa}$ $f2 = f_{RXa} + 100\text{ kHz}$ Input 2 signals ( $f1, f2$ )	10	25	—	dBm	—
C-9	Input P1dB LG	IP1dBLa	Low-Gain mode	0	9	—	dBm	—
C-10	Reverse Isolation HG	ISOHa	High-Gain mode	21	26	—	dB	—
C-11	Reverse Isolation LG	ISOLa	Low-Gain mode	8	10.5	—	dB	—

Note) \*1 : RF input connector & substrate loss (0.26 dB) included.

■ Electrical Characteristics (Reference values for design) (continued) at  $V_{CC} = 3.3\text{ V}$

Notes)  $T_a = 25^\circ\text{C} \pm 2^\circ\text{C}$ ,  $f_{RX} = 5.15\text{ GHz}, 5.5\text{ GHz}, 5.85\text{ GHz}$ ,  $PRX = -30\text{ dBm}$ , CW unless otherwise specified.

The characteristics listed below are reference values derived from the design of the IC and are not guaranteed by inspection.

If a problem does occur related to these characteristics, we will respond in good faith to user concerns.

B No.	Parameter	Symbol	Conditions	Reference values			Unit	Note
				Min	Typ	Max		
AC electrical characteristics								
C-12	Input Return Loss HG	S11Ha	High-Gain mode	6.5	12	—	dB	—
C-13	Input Return Loss LG	S11La	Low-Gain mode	3.5	5	—	dB	—
C-14	Output Return Loss HG	S22Ha	High-Gain mode	9	16	—	dB	—
C-15	Output Return Loss LG	S22La	Low-Gain mode	5	6.5	—	dB	—

### ■ Control Pin Mode Table

Note) See parameters B No. DC-3 / B No. DC-4 in the Electrical Characteristics for control voltage retention ranges.

Pin No.	Description	Pin voltage		Remarks
		Low	High	
B1	High-Gain/Low-Gain Switching (Gain Control)	Low-Gain	High-Gain	—

### ■ Truth Table

Note) See parameters B No. DC-3 / B No. DC-4 in the Electrical Characteristics for control voltage retention ranges.

CNT	LNA	Mode
High	High-Gain	High-Gain
Low	Low-Gain	Low-Gain

### ■ Technical Data

- I/O block circuit diagram and pin function descriptions

Note) The characteristics listed below are reference values derived from the design of the IC and are not guaranteed.

Pin No.	Waveform and voltage	Internal circuit	Impedance	Description
A1	0.8 V		—	LNA input
A2	0.0 V	—	—	GND
A3	—		—	LNA output
B1	—		170 kΩ	High-Gain/Low-Gain SW input Less than 0.60 V : Low-Gain mode More than 1.48 V : High-Gain mode
B3	3.3 V		—	Voltage supply

- Technical Data (continued)
- $P_D - T_a$  diagram

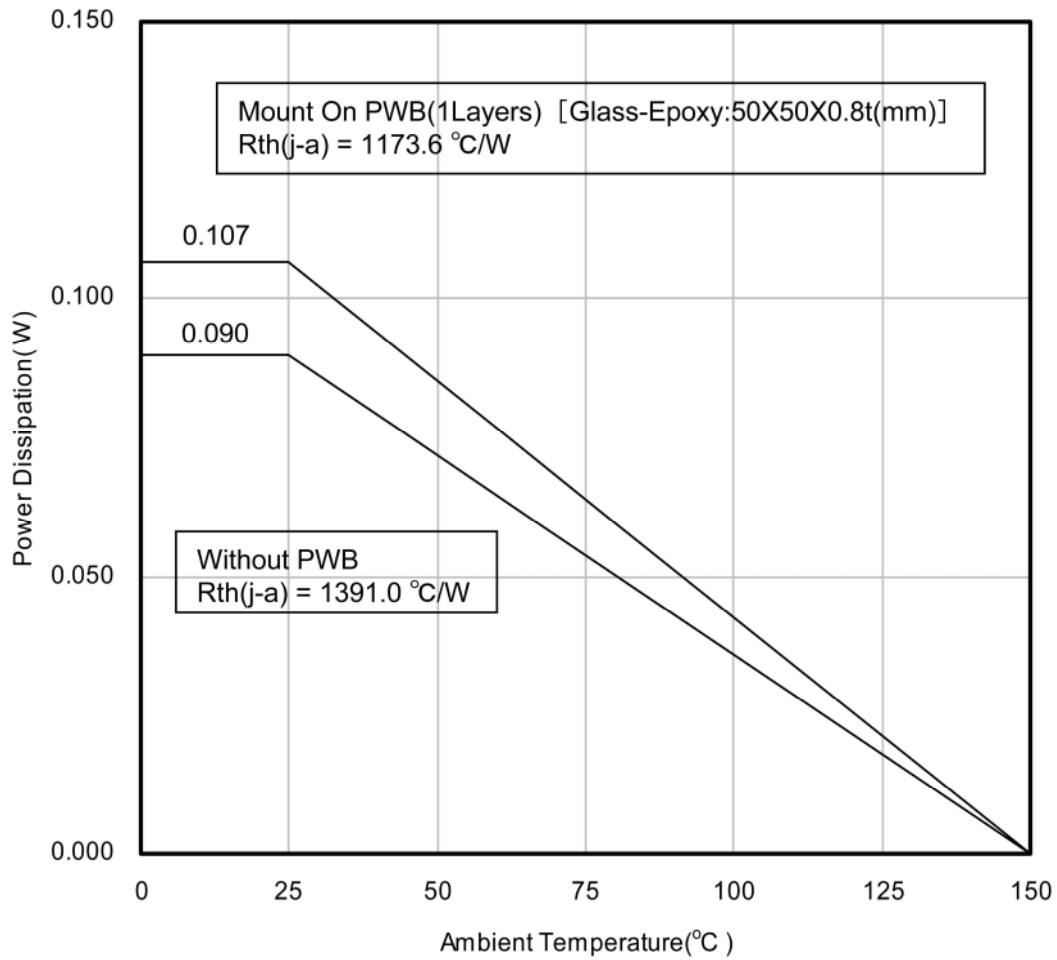

**■ Usage Notes****• Special attention and precaution in using**

1. This IC is intended to be used for general electronic equipment [5 GHz Band Applications].  
Consult our sales staff in advance for information on the following applications:
  - Special applications in which exceptional quality and reliability are required, or if the failure or malfunction of this IC may directly jeopardize life or harm the human body.
  - Any applications other than the standard applications intended.
    - (1) Space appliance (such as artificial satellite, and rocket)
    - (2) Traffic control equipment (such as for automobile, airplane, train, and ship)
    - (3) Medical equipment for life support
    - (4) Submarine transponder
    - (5) Control equipment for power plant
    - (6) Disaster prevention and security device
    - (7) Weapon
    - (8) Others : Applications of which reliability equivalent to (1) to (7) is required
2. Pay attention to the direction of LSI. When mounting it in the wrong direction onto the PCB (printed-circuit-board), it might smoke or ignite.
3. Pay attention in the PCB (printed-circuit-board) pattern layout in order to prevent damage due to short circuit between pins. In addition, refer to the Pin Description for the pin configuration.
4. Perform a visual inspection on the PCB before applying power, otherwise damage might happen due to problems such as a solder-bridge between the pins of the semiconductor device. Also, perform a full technical verification on the assembly quality, because the same damage possibly can happen due to conductive substances, such as solder ball, that adhere to the LSI during transportation.
5. Take notice in the use of this product that it might break or occasionally smoke when an abnormal state occurs such as output pin-VCC short (Power supply fault), output pin-GND short (Ground fault), or output-to-output-pin short (load short) .  
And, safety measures such as an installation of fuses are recommended because the extent of the above-mentioned damage and smoke emission will depend on the current capability of the power supply.
6. When designing your equipment, comply with the range of absolute maximum rating and the guaranteed operating conditions (operating power supply voltage and operating environment etc.). Especially, please be careful not to exceed the range of absolute maximum rating on the transient state, such as power-on, power-off and mode-switching. Otherwise, we will not be liable for any defect which may arise later in your equipment.  
Even when the products are used within the guaranteed values, take into the consideration of incidence of break down and failure mode, possible to occur to semiconductor products. Measures on the systems such as redundant design, arresting the spread of fire or preventing glitch are recommended in order to prevent physical injury, fire, social damages, for example, by using the products.
7. When using the LSI for new models, verify the safety including the long-term reliability for each product.
8. When the application system is designed by using this LSI, be sure to confirm notes in this book.  
Be sure to read the notes to descriptions and the usage notes in the book.
9. Due to unshielded structure of this IC, under exposure of light, function and characteristic of the product cannot be guaranteed.  
During normal operation or even under testing condition, please ensure that IC is not exposed to light.
10. Basically, chip surface is ground potential. Please design to ensure no contact between chip surface and metal shielding.

## Request for your special attention and precautions in using the technical information and semiconductors described in this book

- (1) If any of the products or technical information described in this book is to be exported or provided to non-residents, the laws and regulations of the exporting country, especially, those with regard to security export control, must be observed.
- (2) The technical information described in this book is intended only to show the main characteristics and application circuit examples of the products. No license is granted in and to any intellectual property right or other right owned by Panasonic Corporation or any other company. Therefore, no responsibility is assumed by our company as to the infringement upon any such right owned by any other company which may arise as a result of the use of technical information described in this book.
- (3) The products described in this book are intended to be used for general applications (such as office equipment, communications equipment, measuring instruments and household appliances), or for specific applications as expressly stated in this book.  
Consult our sales staff in advance for information on the following applications:
  - Special applications (such as for airplanes, aerospace, automotive equipment, traffic signaling equipment, combustion equipment, life support systems and safety devices) in which exceptional quality and reliability are required, or if the failure or malfunction of the products may directly jeopardize life or harm the human body.It is to be understood that our company shall not be held responsible for any damage incurred as a result of or in connection with your using the products described in this book for any special application, unless our company agrees to your using the products in this book for any special application.
- (4) The products and product specifications described in this book are subject to change without notice for modification and/or improvement. At the final stage of your design, purchasing, or use of the products, therefore, ask for the most up-to-date Product Standards in advance to make sure that the latest specifications satisfy your requirements.
- (5) When designing your equipment, comply with the range of absolute maximum rating and the guaranteed operating conditions (operating power supply voltage and operating environment etc.). Especially, please be careful not to exceed the range of absolute maximum rating on the transient state, such as power-on, power-off and mode-switching. Otherwise, we will not be liable for any defect which may arise later in your equipment.  
Even when the products are used within the guaranteed values, take into the consideration of incidence of break down and failure mode, possible to occur to semiconductor products. Measures on the systems such as redundant design, arresting the spread of fire or preventing glitch are recommended in order to prevent physical injury, fire, social damages, for example, by using the products.
- (6) Comply with the instructions for use in order to prevent breakdown and characteristics change due to external factors (ESD, EOS, thermal stress and mechanical stress) at the time of handling, mounting or at customer's process. When using products for which damp-proof packing is required, satisfy the conditions, such as shelf life and the elapsed time since first opening the packages.
- (7) This book may be not reprinted or reproduced whether wholly or partially, without the prior written permission of our company.