

DATA SHEET

Part No.	AN32150B
Package Code No.	ULGA055-W-3940AKL

Contents

■ Overview	3
■ Features	3
■ Applications	3
■ Package	3
■ Type	3
■ Application Circuit Example (Block Diagram)	4
■ Pin Descriptions	6
■ Absolute Maximum Ratings	10
■ Operating Supply Voltage Range	10
■ Allowable Voltage Range	11
■ Electrical Characteristics	12
■ Technical Data	23
• $P_D - T_a$ diagram	23
■ Usage Notes	24

AN32150B

LED driver IC with step-up charge pump control circuit

■ Overview

AN32150B is equipped with LED drivers for LCD backlights, drivers for LED matrix, drivers for RGB, and light intensity controller. Voltage is supplied by a step-up charge pump DC-DC converter.

■ Features

- LED matrix driver 7×7
- Step-up charge pump DC/DC converter : 300 mA
- LDO : 2-ch.
- GPIO : 3-ch.
- GPO : 6-ch. (They are in common with LED driver terminals.)
- SPI interface / I²C interface selectable
- LED drivers (for backlights : 7-ch., for RGB : 3-ch., matrix LED driver : 7×7 -ch.)
- LED brightness control function with an external illumination sensor

■ Applications

- LED driver IC

■ Package

- 55pin Wafer Level Chip Size Package (WLCSP) (Size : 3.96 mm \times 3.86 mm, 0.5 mm Pitch)

■ Type

- Bi-CMOS IC

■ Application Circuit Example (Block Diagram)

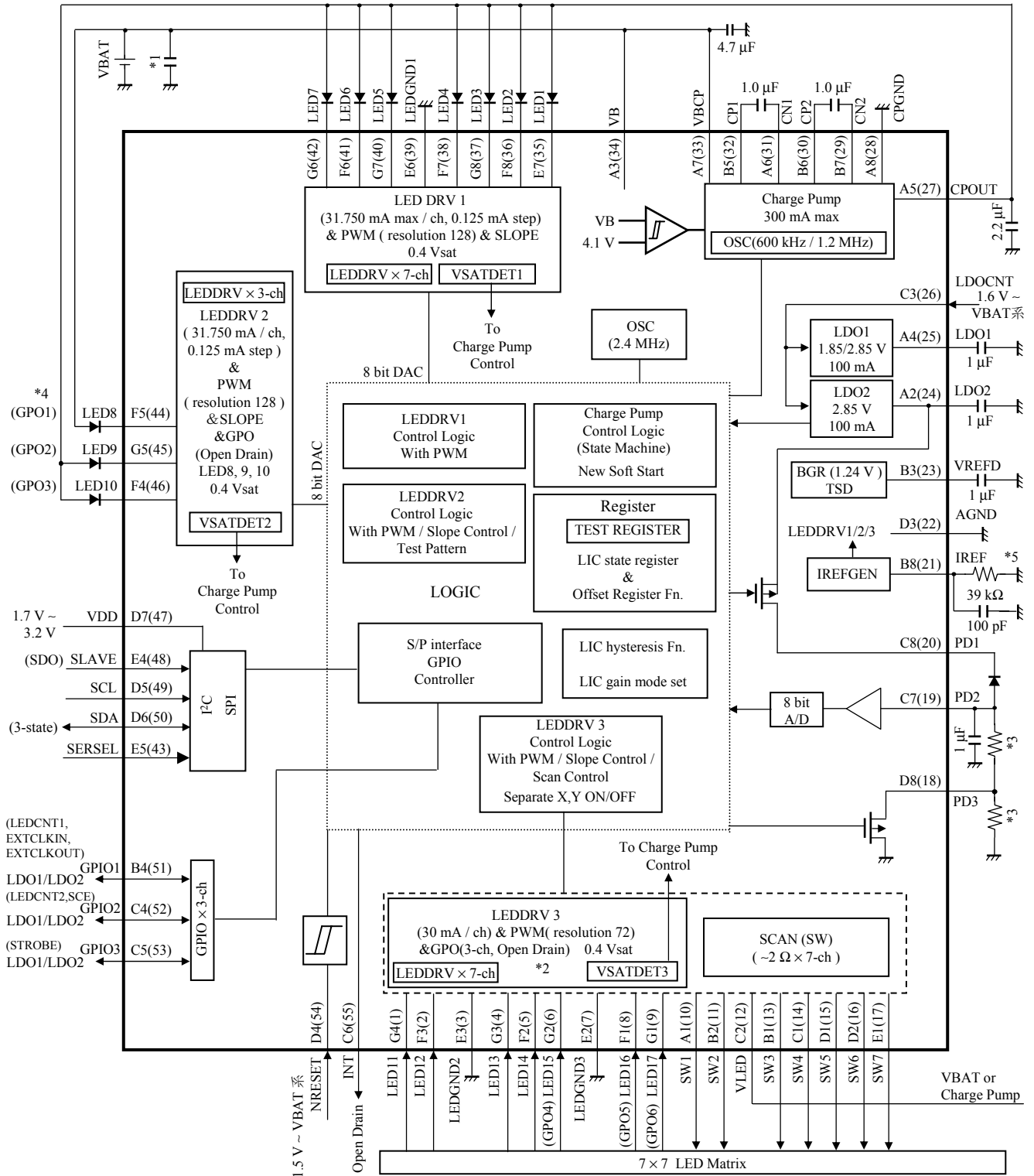

■ Application Circuit Example (Block Diagram) (continued)

- Notes)
- This application circuit is shown as an example but does not guarantee the design for mass production set.
 - This block diagram is for explaining functions. The part of the block diagram may be omitted, or it may be simplified.
- *1 : Capacitor of VBAT line is used for reducing noise. Choose the capacitance value according to the PCB pattern.
- *2 : Steps about LEDDRV3 current value setting are 1 mA, 2 mA, 3 mA, 4 mA, 5 mA, 8 mA, 11 mA, 15 mA, 17 mA, 19 mA, 21 mA, 24 mA, 26 mA, 28 mA, 30 mA.
- *3 : Adjust the value of an external resistor and capacitor for modulated LED light according to the photo diode characteristics to use.
- *4 : When voltage is supplied to VLED pin from external power supply, 3.1 V or more should be applied.
(If it is not applied, LED1 to 17 terminals (the current source) do not operate.)
- *5 : It is recommended to use ERJ2RHD393X ($\pm 0.5\%$) (Panasonic) to connect resistors to keep the accuracy of constant current in each LED.

■ Pin Descriptions

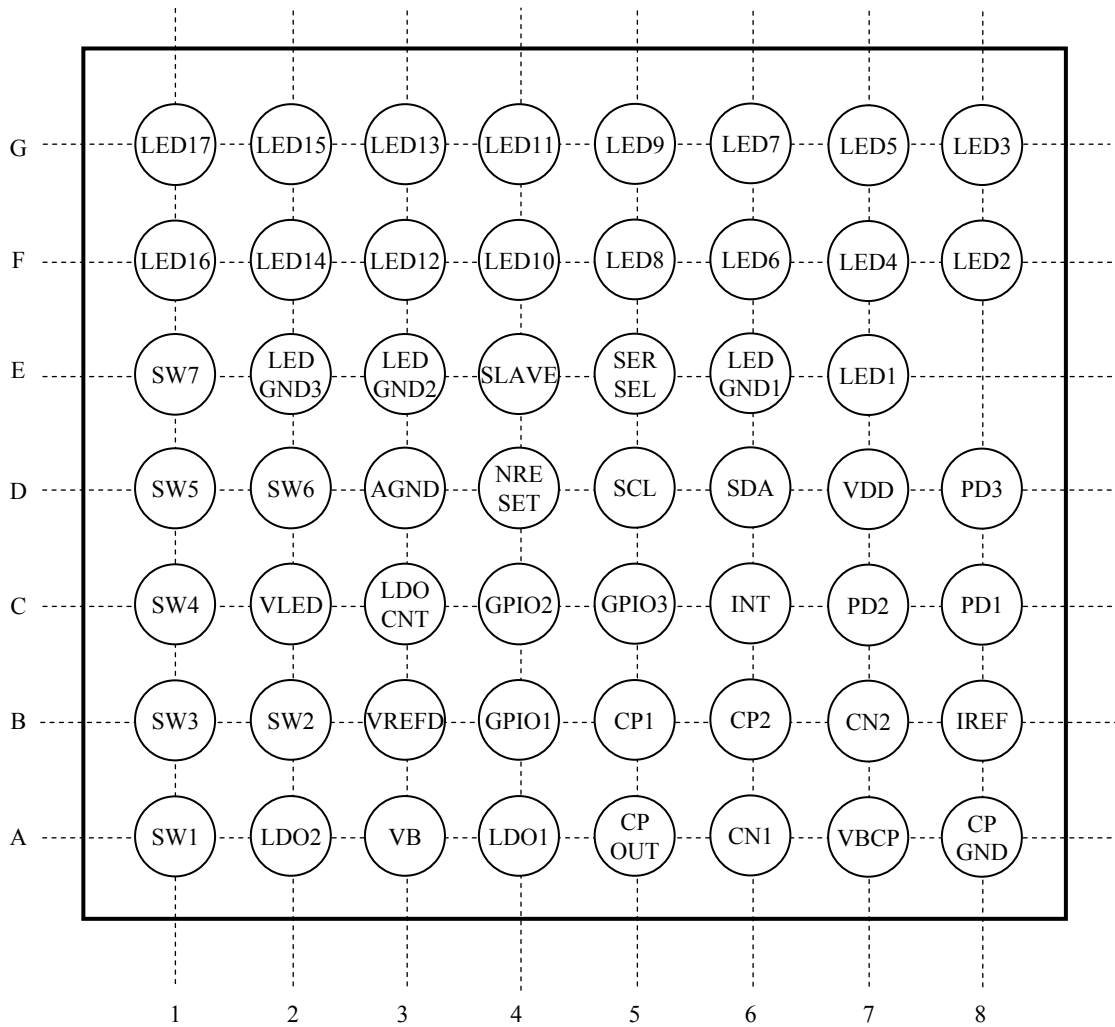

Bottom View

■ Pin Descriptions (continued)

Pin No. (Pad No.)	Pin name	Type	Description	Pin processing at unused
A1(10)	SW1	Output	Control switch pin for matrix driver Connected to A column of matrix LED.	Open
A2(24)	LDO2	Output	LDO2 (2.85 V) output pin	(Required pin)
A3(34)	VB	Power supply	Power supply connection pin for BGR and LDO circuits	(Required pin)
A4(25)	LDO1	Output	LDO1 (1.85 V / 2.85 V) output pin (Default : 1.85 V output)	(Required pin)
A5(27)	CPOUT	Output	Charge pump output pin (Output pin for VB through SW)	Open
A6(31)	CN1	Output	Capacitor connection pin for charge pump DC-DC converter	Open
A7(33)	VBCP	Power supply	Power supply connection pin for charge pump DC-DC converter and for through switch	(Required pin)
A8(28)	CPGND	Ground	GND for charge pump DC-DC converter	Connect to GND
B1(13)	SW3	Output	Control switch pin for matrix driver Connected to C column of matrix LED.	Open
B2(11)	SW2	Output	Control switch pin for matrix driver Connected to B column of matrix LED.	Open
B3(23)	VREFD	Output	Capacitor connection pin for BGR circuit	(Required pin)
B4(51)	GPIO1	Input / Output	GPIO input / output port pin (Default input mode with pull-down)	Recommended to connect to GND
B5(32)	CP1	Output	Capacitor connection pin for charge pump DC-DC converter	Open
B6(30)	CP2	Output	Capacitor connection pin for charge pump DC-DC converter	Open
B7(29)	CN2	Output	Capacitor connection pin for charge pump DC-DC converter	Open
B8(21)	IREF	Output	Resistor connection pin for constant current setup	(Required pin)
C1(14)	SW4	Output	Control switch pin for matrix driver Connected to D column of matrix LED.	Open
C2(12)	VLED	Power supply	Power supply for matrix driver Connected to the output of battery or step-up charge pump DC/DC converter.	Connect to VBAT or CPOUT (Open disabled)
C3(26)	LDOCNT	Input	BGR circuit, ON/OFF control pin of LDO1 and LDO2	(Required pin)
C4(52)	GPIO2	Input / Output	GPIO input / output port pin (Default input mode with pull-down) At SERSEL pin = High (SPI mode) : SCE pin	Recommended to connect to GND
C5(53)	GPIO3	Input / Output	GPIO input / output port pin (Default input mode with pull-down)	Recommended to connect to GND
C6(55)	INT	Output	Interrupt output pin	Open
C7(19)	PD2	Input	Photo diode connection pin	Connect to GND
C8(20)	PD1	Output	Photo diode connection pin	Open
D1(15)	SW5	Output	Control switch pin for matrix driver Connected to E column of matrix LED.	Open
D2(16)	SW6	Output	Control switch pin for matrix driver Connected to F column of matrix LED.	Open
D3(22)	AGND	Ground	GND for analog block	Connect to GND

■ Pin Descriptions (continued)

Pin No. (Pad No.)	Pin name	Type	Description	Pin processing at unused
D4(54)	NRESET	Input	Reset input pin	(Required pin)
D5(49)	SCL	Input	SPI / I ² C interface common clock input pin	(Required pin)
D6(50)	SDA	Input / Output	Data input / output pin for I ² C interface At SERSEL pin = High (SPI mode) : Data input pin	(Required pin)
D7(47)	VDD	Power supply	Power supply for I ² C interface	(Required pin)
D8(18)	PD3	Input	Detection resistor connection pin for photo diode adjustment	Open
E1(17)	SW7	Output	Control switch pin for matrix driver Connected to G column of matrix LED.	Open
E2(7)	LEDGND3	Ground	GND for matrix LED	Connect to GND
E3(3)	LEDGND2	Ground	GND for matrix LED	Connect to GND
E4(48)	SLAVE	Input / Output	Slave address selection pin for I ² C interface At SERSEL pin = High (SPI mode) : SDO pin	(Required pin)
E5(43)	SERSEL	Input	I ² C / SPI interface selection pin	Connect to GND or VDD
E6(39)	LEDGND1	Ground	GND for BL pin	Connect to GND
E7(35)	LED1	Output	Constant current output pin for LED driver	Open
F1(8)	LED16	Output	Constant current circuit, PWM control output pin Connected to the 6th row of matrix LED. And GPO (open drain) output pin	Open
F2(5)	LED14	Output	Constant current circuit, PWM control output pin Connected to the 4th row of matrix LED.	Open
F3(2)	LED12	Output	Constant current circuit, PWM control output pin Connected to the 2nd row of matrix LED.	Open
F4(46)	LED10	Output	Constant current output pin for LED driver, and GPO (open drain) output pin	Open
F5(44)	LED8	Output	Constant current output pin for LED driver, and GPO (open drain) output pin	Open
F6(41)	LED6	Output	Constant current output pin for LED driver	Open
F7(38)	LED4	Output	Constant current output pin for LED driver	Open
F8(36)	LED2	Output	Constant current output pin for LED driver	Open
G1(9)	LED17	Output	Constant current circuit, PWM control output pin Connected to the 7th row of matrix LED. And GPO (open drain) output pin	Open
G2(6)	LED15	Output	Constant current circuit, PWM control output pin Connected to the 5th row of matrix LED. And GPO (open drain) output pin	Open
G3(4)	LED13	Output	Constant current circuit, PWM control output pin Connected to the 3rd row of matrix LED.	Open
G4(1)	LED11	Output	Constant current circuit, PWM control output pin Connected to the 1st row of matrix LED.	Open

■ Pin Descriptions (continued)

Pin No. (Pad No.)	Pin name	Type	Description	Pin processing at unused
G5(45)	LED9	Output	Constant current output pin for LED driver, and GPO (open drain) output pin	Open
G6(42)	LED7	Output	Constant current output pin for LED driver	Open
G7(40)	LED5	Output	Constant current output pin for LED driver	Open
G8(37)	LED3	Output	Constant current output pin for LED driver	Open

■ Absolute Maximum Ratings

Note) Absolute maximum ratings are limit values which do not result in damages to this IC, and IC operation is not guaranteed at these limit values.

A* No.	Parameter	Symbol	Rating	Unit	Notes
1	Supply voltage	$V_{B_{MAX}}$	6.0	V	*1
		$V_{LED_{MAX}}$	6.5	V	*1
		$V_{DD_{MAX}}$	4.3	V	*1
2	Supply current	I_{CC}	—	A	—
3	Power dissipation	P_D	76	mW	*2
4	Operating ambient temperature	T_{opr}	−30 to + 85	°C	*3
5	Storage temperature	T_{stg}	−55 to + 125	°C	*3

Notes) * : "A" is a management number for this page in our company.

*1 : $V_{B_{MAX}} = V_{BCP} = V_B$, $V_{DD_{MAX}} = V_{DD}$

The values under the condition not exceeding the above absolute maximum ratings and the power dissipation.

*2 : The power dissipation shown is the value at $T_a = 85^\circ\text{C}$ for the independent (unmounted) IC package without a heat sink.

When using this IC, refer to the $P_D - T_a$ diagram in the ■ Technical Data and design the heat radiation with sufficient margin so that the allowable value might not be exceeded based on the conditions of power supply voltage, load, and ambient temperature.

*3 : Except for the power dissipation, operating ambient temperature, and storage temperature, all ratings are for $T_a = 25^\circ\text{C}$.

■ Operating Supply Voltage Range

Parameter	Symbol	Range	Unit	Notes
Supply voltage range	V_{BCP} V_B	3.1 to 4.6	V	*1
	V_{LED}	3.1 to 5.8	V	*1
	V_{DD}	1.7 to 3.2	V	*1, 2

Note) * 1 : The values under the condition not exceeding the above absolute maximum ratings and the power dissipation.

*2 : V_{DD} voltage must be applied in the range which does not exceeds V_B and V_{BCP} voltage.

■ Allowable Voltage Range

- Notes) • Allowable voltage ranges are limit ranges which do not result in damages to this IC, and IC operation is not guaranteed within these limit ranges.
- Voltage values, unless otherwise specified, are with respect to GND.
GND is voltage for AGND, LEDGND1, LEDGND2, LEDGND3, and CPGND.
AGND = LEDGND1 = LEDGND2 = LEDGND3 = CPGND
 - VCC1 is voltage for VB and VBCP.
 - Do not apply external currents or voltages to any pin not specifically mentioned.

Pin No. (Pad No.)	Pin name	Rating	Unit	Note
B4(51)	GPIO1	(At IOVSEL1 = [0]) – 0.3 to (LDO2 + 0.3) (At IOVSEL1 = [1]) – 0.3 to (LDO1 + 0.3)	V	*1
C3(26)	LDOCNT	– 0.3 to (VCC1 + 0.3)	V	*2
C4(52)	GPIO2	(At SERSEL = GND, IOVSEL2 = [0]) – 0.3 to (LDO2 + 0.3) (At SERSEL = GND, IOVSEL2 = [1]) – 0.3 to (LDO1 + 0.3) (At SERSEL = VDD) – 0.3 to (VDD + 0.5)	V	*1 *2
C5(53)	GPIO3	(At IOVSEL3 = [0]) – 0.3 to (LDO2 + 0.3) (At IOVSEL3 = [1]) – 0.3 to (LDO1 + 0.3)	V	*1

Pin No. (Pad No.)	Pin name	Rating	Unit	Note
C7(19)	PD2	– 0.3 to (LDO2 + 0.3)	V	—
D4(54)	NRESET	– 0.3 to (VCC1 + 0.3)	V	*2
D5(49)	SCL	– 0.5 to (VDD + 0.5)	V	*2
D6(50)	SDA	– 0.5 to (VDD + 0.5)	V	*1 *2
D8(18)	PD3	– 0.3 to (LDO2 + 0.3)	V	—
E4(48)	SLAVE	– 0.3 to (VDD + 0.5)	V	*1 *2
E5(43)	SERSEL	– 0.3 to (VDD + 0.5)	V	*2

- Notes) *1 : Rating when used for input. External voltage or current must not be applied when used for output.
*2 : (VCC1 + 0.3) V must not be exceeded 6 V, and (VDD + 0.5) V must not be exceeded 4.3 V.

B* No.	Parameter	Symbol	Conditions	Limits			Unit	Notes
				Min	Typ	Max		
Current consumption								
1	Current consumption (1) at OFF mode	ICC1	VB = 4.6 V LDOCNT = Low ICC1 = IP33 + IP34	—	0	1	μA	—
2	Current consumption (2) at LDO1 and LDO2 normal mode	ICC2	LDO1 to 2PS = [0] (LDO1, 2 normal mode) LDO1ON = [1] (LDO1 ON) VB = 4.6 V LDOCNT = High ICC2 = IP33 + IP34	—	130	300	μA	—
3	Current consumption (3) at LDO1 OFF mode, LDO2 power save mode	ICC3	LDO2 PS = [1] (LDO2 power save mode) LDO1ON = [0] (LDO1 OFF) VB = 4.6 V LDOCNT = High ICC3 = IP33 + IP34	—	10	25	μA	—
4	Current consumption (4) at VB through mode, LDO1 OFF mode, LDO2 power save mode	ICC4	LDO2 PS = [1] (LDO2 power save mode) LDO1ON = [0] (LDO1 OFF) VB = 4.6 V LDOCNT = High VB through mode IP27 = 0 mA LED10ON = [1] (Current 0) ICC4 = IP33 + IP34	—	1.0	3.0	mA	—
5	Current consumption (5) at charge pump 1.5× (600 kHz operating) mode, LDO1 OFF mode, LDO2 power save mode	ICC5	LDO2 PS = [1] (LDO2 power save mode) LDO1ON = [0] (LDO1 OFF) VB = 3.1 V LDOCNT = High LED10ON = [1] (current 0) Charge Pump ON, 1.5×, 600 kHz operating mode IP27 = 0 mA ICC5 = IP33 + IP34	—	2.0	5.0	mA	—
6	Current consumption (6) at charge pump 1.5× (1.2 MHz operating) mode, LDO1 OFF mode, LDO2 power save mode	ICC6	LDO2 PS = [1] (LDO2 power save mode) LDO1ON = [0] (LDO1 OFF) VB = 3.1 V LDOCNT = High LED10ON = [1] (current 0) Charge Pump ON, 1.5×, 1.2 MHz operating mode IP27 = 0 mA ICC6 = IP33 + IP34	—	5.0	9.0	mA	—

■ Electrical Characteristics (continued) at $V_B = V_{BCP} = 3.6\text{ V}$, $V_{LED} = 4.5\text{ V}$, $V_{DD} = 1.85\text{ V}$

Note) $T_a = 25^\circ\text{C} \pm 2^\circ\text{C}$ unless otherwise specified.

B No.	Parameter	Symbol	Conditions	Limits			Unit	Notes
				Min	Typ	Max		
Reference voltage								
7	Output voltage	VREF	$V_B = 3.1\text{ V to }4.6\text{ V}$ $V_{REF} = V_{P23}$	1.21	1.24	1.27	V	—
Voltage regulator (LDO1) normal mode $I_{outmax} = -100\text{ mA}$								
8	Output voltage (1) 1.85 V mode	VL11	$V_B = 3.1\text{ V to }4.6\text{ V}$ $I_{P25} = -10\text{ }\mu\text{A to }-100\text{ mA}$ $V_{L11} = V_{P25}$	1.79	1.85	1.91	V	—
9	Output voltage (2) 2.85 V mode	VL12	$V_B = 3.1\text{ V to }4.6\text{ V}$ $I_{P25} = -10\text{ }\mu\text{A to }-100\text{ mA}$ $V_{L12} = V_{P25}$	2.76	2.85	2.94	V	—
10	Short circuit protection current (1) 1.85 V mode	IPT11	LDOCNT = High $V_{P25} = 0\text{ V}$ $I_{PT11} = I_{P25}$	20	50	150	mA	—
11	Short circuit protection current (2) 2.85 V mode	IPT12	LDOCNT = High $V_{P25} = 0\text{ V}$ $I_{PT12} = I_{P25}$	20	50	150	mA	—
12	Ripple rejection (1) 1.85 V mode	PSL11	$V_B = 3.6\text{ V} + 0.2\text{ V[p-p]}$ $f = 1\text{ kHz}$ $I_{P25} = -50\text{ mA}$ $PSL11 = 20\text{ log(acVP25 / 0.2)}$	—	-70	-60	dB	—
13	Ripple rejection (2) 1.85 V mode	PSL12	$V_B = 3.6\text{ V} + 0.2\text{ V[p-p]}$ $f = 10\text{ kHz}$ $I_{P25} = -50\text{ mA}$ $PSL12 = 20\text{ log(acVP25 / 0.2)}$	—	-60	-50	dB	—
14	Ripple rejection (3) 2.85 V mode	PSL13	$V_B = 3.6\text{ V} + 0.2\text{ V[p-p]}$ $f = 1\text{ kHz}$ $I_{P25} = -50\text{ mA}$ $PSL13 = 20\text{ log(acVP25 / 0.2)}$	—	-70	-60	dB	—
15	Ripple rejection (4) 2.85 V mode	PSL14	$V_B = 3.6\text{ V} + 0.2\text{ V[p-p]}$ $f = 10\text{ kHz}$ $I_{P25} = -50\text{ mA}$ $PSL14 = 20\text{ log(acVP25 / 0.2)}$	—	-60	-50	dB	—

■ Electrical Characteristics (continued) at $V_B = V_{BCP} = 3.6\text{ V}$, $V_{LED} = 4.5\text{ V}$, $V_{DD} = 1.85\text{ V}$

Note) $T_a = 25^\circ\text{C} \pm 2^\circ\text{C}$ unless otherwise specified.

B No.	Parameter	Symbol	Conditions	Limits			Unit	Notes
				Min	Typ	Max		
Voltage regulator (LDO1) power save mode : $I_{outmax} = -15\text{ mA}$ ($I_{outmax} = -5\text{ mA}$ at 2.85 V setting)								
16	Output voltage (1)	VLPS11	$V_B = 3.1\text{ V to }4.6\text{ V}$ $I_{P25} = -10\ \mu\text{A to }-15\text{ mA}$ $VLPS11 = VP25$	1.79	1.85	1.91	V	—
17	Output voltage (2)	VLPS12	$V_B = 3.1\text{ V to }4.6\text{ V}$ $I_{P25} = -10\ \mu\text{A to }-5\text{ mA}$ $VLPS12 = VP25$	2.76	2.85	2.94	V	—

■ Electrical Characteristics (continued) at $V_B = V_{BCP} = 3.6\text{ V}$, $V_{LED} = 4.5\text{ V}$, $V_{DD} = 1.85\text{ V}$

Note) $T_a = 25^\circ\text{C} \pm 2^\circ\text{C}$ unless otherwise specified.

B No.	Parameter	Symbol	Conditions	Limits			Unit	Notes
				Min	Typ	Max		
Voltage regulator (LDO2) normal mode $I_{outmax} = -100\text{ mA}$								
18	Output voltage	VL2	$V_B = 3.1\text{ V to }4.6\text{ V}$ $I_{P24} = -10\ \mu\text{A to }-100\text{ mA}$ $V_{L2} = V_{P24}$	2.76	2.85	2.94	V	—
19	Short circuit protection current	IPT2	LDOCNT = High $V_{P24} = 0\text{ V}$ $I_{PT2} = I_{P24}$	20	50	150	mA	—
20	Ripple rejection (1)	PSL21	$V_B = 3.6\text{ V} + 0.2\text{ V[p-p]}$ $f = 1\text{ kHz}$ $I_{P24} = -50\text{ mA}$ $PSL21 = 20\ \log(acVP24 / 0.2)$	—	-70	-60	dB	—
21	Ripple rejection (2)	PSL22	$V_B = 3.6\text{ V} + 0.2\text{ V[p-p]}$ $f = 10\text{ kHz}$ $I_{P24} = -50\text{ mA}$ $PSL22 = 20\ \log(acVP24 / 0.2)$	—	-60	-50	dB	—
Voltage regulator (LDO2) power save mode $I_{outmax} = -5\text{ mA}$								
22	Output voltage	VLPS2	$V_B = 3.1\text{ V to }4.6\text{ V}$ $I_{P24} = -10\ \mu\text{A to }-5\text{ mA}$ $V_{L2} = V_{P24}$	2.76	2.85	2.94	V	—

■ Electrical Characteristics (continued) at $V_B = V_{BCP} = 3.6\text{ V}$, $V_{LED} = 4.5\text{ V}$, $V_{DD} = 1.85\text{ V}$

Note) $T_a = 25^\circ\text{C} \pm 2^\circ\text{C}$ unless otherwise specified.

B No.	Parameter	Symbol	Conditions	Limits			Unit	Notes
				Min	Typ	Max		
Charge pump DC-DC converter								
23	Oscillator frequency	FDC1	$V_B = 3.1\text{ V to }4.6\text{ V}$	1.92	2.40	2.88	MHz	—
VB through switch								
24	Resistance at switch ON	RVBS	$V_B = 4.5\text{ V}$ IP27 = -30 mA $RVBS = (VP33 - VP27) / 30\text{ mA}$	—	0.6	1	Ω	—
SCAN switch								
25	Resistance at switch ON	RSCAN	$V_{LED} = 4.5\text{ V}$ IP10, 11, 13 to 17 = 20 mA RSCAN = VP10, 11 13 to 18 / 20 mA	—	1	2	Ω	—

■ Electrical Characteristics (continued) at $V_B = V_{BCP} = 3.6\text{ V}$, $V_{LED} = 4.5\text{ V}$, $V_{DD} = 1.85\text{ V}$

Note) $T_a = 25^\circ\text{C} \pm 2^\circ\text{C}$ unless otherwise specified.

B No.	Parameter	Symbol	Conditions	Limits			Unit	Notes
				Min	Typ	Max		
Current regulator (LED1 to 7)								
26	Output current (1)	IBL1	At 31.750 mA setting VP35 to 38, 40 to 42 = 1 V IBL1 = IP35 to 38, 40 to 42	30.132	31.718	33.304	mA	*1
27	Output current (2)	IBL2	At 1 mA setting VP35 to 38, 40 to 42 = 1 V IBL2 = IP35 to 38, 40 to 42	0.948	0.998	1.048	mA	*1
28	Current step	IBSTEP	Minimum current step	0	125	250	μA	—
29	Off leak current	IBLOFF	OFF setting VP35 to 38, 40 to 42 = 4.5 V IBLOFF = IP35 to 38, 40 to 42	—	—	1	μA	—
30	Error between channels	IBLCH	At 16 mA setting Current error between each channel and the median of LED1 to 7	-5	—	5	%	—

■ Electrical Characteristics (continued) at $V_B = V_{BCP} = 3.6\text{ V}$, $V_{LED} = 4.5\text{ V}$, $V_{DD} = 1.85\text{ V}$

Note) $T_a = 25^\circ\text{C} \pm 2^\circ\text{C}$ unless otherwise specified.

B No.	Parameter	Symbol	Conditions	Limits			Unit	Notes
				Min	Typ	Max		
Current regulator (LED8 to 10)								
31	Output current (1)	IRGB1	At 31.750 mA setting VP44 to 46 = 1 V IRGB1 = IP44 to 46	30.087	31.671	33.254	mA	*1
32	Output current (2)	IRGB2	At 1 mA setting VP 44 to 46 = 1 V IRGB2 = IP44 to 46	0.946	0.996	1.046	mA	*1
33	Current step	IRGBSTEP	Minimum current step	0	125	250	μA	—
34	Off leak current	IRGBOFF	OFF setting VP 44 to 46 = 4.5 V IRGBOFF = IP44 to 46	—	—	1	μA	—
35	Error between channels	IRGBCH	At 16 mA setting Current error between each channel and the median of LED8 to 10	-5	—	5	%	—
Current regulator (LED11 to 17)								
36	Output current (1)	IMX1	At 1 mA setting VP1, 2, 4 to 6, 8, 9 = 1 V IMX1 = IP1, 2, 4 to 6, 8, 9	0.943	0.993	1.043	mA	*1, 2
37	Output current (2)	IMX2	At 2 mA setting VP1, 2, 4 to 6, 8, 9 = 1 V IMX2 = IP1, 2, 4 to 6, 8, 9	1.891	1.990	2.090	mA	*1, 2
38	Output current (3)	IMX3	At 4 mA setting VP1, 2, 4 to 6, 8, 9 = 1 V IMX2 = IP1, 2, 4 to 6, 8, 9	3.768	3.966	4.164	mA	*1, 2
39	Output current (4)	IMX4	At 8 mA setting VP1, 2, 4 to 6, 8, 9 = 1 V IMX2 = IP1, 2, 4 to 6, 8, 9	7.558	7.956	8.354	mA	*1, 2
40	Output current (5)	IMX5	At 15 mA setting VP1, 2, 4 to 6, 8, 9 = 1 V IMX2 = IP1, 2, 4 to 6, 8, 9	14.172	14.918	15.663	mA	*1, 2
41	Off leak current	IMXOFF	OFF setting VP1, 2, 4 to 6, 8, 9 = 4.5 V IMXOFF = IP1, 2, 4 to 6, 8, 9	—	—	1	μA	—
42	Error between channels	IMXCH	At 15 mA setting Current error between each channel and the median of LED11 to 17	-5	—	5	%	—

■ Electrical Characteristics (continued) at $V_B = V_{BCP} = 3.6\text{ V}$, $V_{LED} = 4.5\text{ V}$, $V_{DD} = 1.85\text{ V}$

Note) $T_a = 25^\circ\text{C} \pm 2^\circ\text{C}$ unless otherwise specified.

B No.	Parameter	Symbol	Conditions	Limits			Unit	Notes
				Min	Typ	Max		
Overvoltage detection								
43	Detection voltage	VOV	Charge pump DC-DC overvoltage detection	5.3	5.5	5.7	V	—
Step-up mode switch of charge pump								
44	Detection voltage (1)	VLD1	LED1 to 7 pin voltage at the time when the step-up mode switch of charge pump changes	—	0.35	0.40	V	—
45	Detection voltage (2)	VLD2	LED8, 9 and 10 pin voltage at the time when the step-up mode switch of charge pump changes	—	0.35	0.40	V	—
Minimum voltage at which LED driver can keep constant current value								
46	Minimum voltage at which LED driver can keep constant current value	VLD3	95% LED current value at the time when LED1 to 17 pin voltage is set to 1 V. Minimum value of LED1 to 17 pin voltage	—	0.20	0.35	V	—

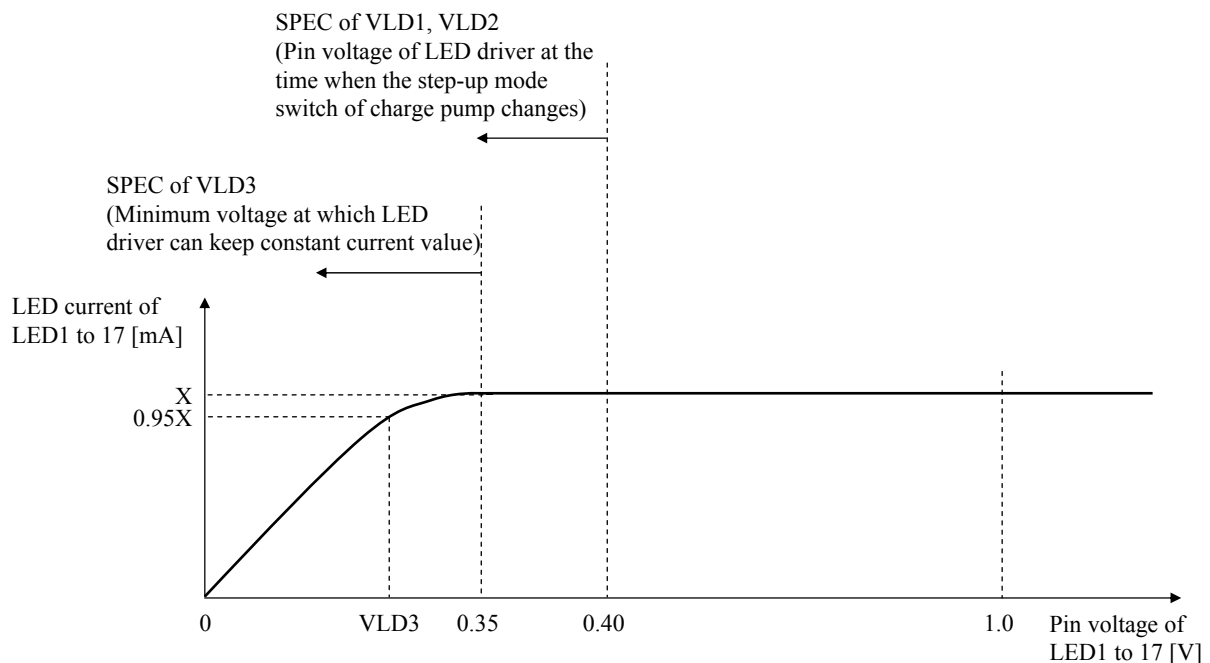

■ Electrical Characteristics (continued) at $V_B = V_{BCP} = 3.6\text{ V}$, $V_{LED} = 4.5\text{ V}$, $V_{DD} = 1.85\text{ V}$

Note) $T_a = 25^\circ\text{C} \pm 2^\circ\text{C}$ unless otherwise specified.

B No.	Parameter	Symbol	Conditions	Limits			Unit	Notes
				Min	Typ	Max		
GPIO I/F								
47	High-level input voltage range (1) at 1.85 V mode operation	VIH1	High-level recognition voltage of GPIO1 to 3. IOVSEL1 to 3 = [1] (Output voltage LDO1 level setting) LDO1VSEL = [0]	1.5	—	LDO1 + 0.3	V	—
48	Low-level input voltage range (1) at 1.85 V mode operation	VIL1	Low-level recognition voltage of GPIO1 to 3. IOVSEL1 to 3 = [1] (Output voltage LDO1 level setting) LDO1VSEL = [0]	-0.3	—	0.4	V	—
49	High-level input voltage range (2) at 2.85 V mode operation	VIH2	High-level recognition voltage of GPIO1 to 3. LDO1VSEL = [1]	2.3	—	LDO1 + 0.3	V	—
50	Low-level input voltage range (2) at 2.85 V mode operation	VIL2	Low-level recognition voltage of GPIO1 to 3. LDO1VSEL = [1]	-0.3	—	0.6	V	—
51	High-level input current	IIH1	VP51 to 53 = 2.85 V IIH1 = IP51 to 53	—	0	1	μA	—
52	Low-level input current	IIL1	VP51 to 53 = 0 V IIL1 = IP51 to 53	—	0	1	μA	—
53	High-level output voltage (1)	VOH1	IP51 to 53 = -2 mA IOVSEL1 to 3 = [0] (Output voltage LDO2 level setting)	LDO2 \times 0.8	—	—	V	—
54	Low-level output voltage (1)	VOL1	IP51 to 53 = 2 mA IOVSEL1 to 3 = [0] (Output voltage LDO2 level setting)	—	—	LDO2 \times 0.2	V	—
55	High-level output voltage (2)	VOH2	IP51 to 53 = -2 mA IOVSEL1 to 3 = [1] (Output voltage LDO1 level setting)	LDO1 \times 0.8	—	—	V	—
56	Low-level output voltage (2)	VOL2	IP51 ~ 53 = 2 mA IOVSEL1 to 3 = [1] (Output voltage LDO1 level setting)	—	—	LDO1 \times 0.2	V	—
57	Pull-down resistance	RPD	IP51 to 53 = 5 μA RPD = VP51 to 53 / 5 μA	60	110	210	k Ω	—

■ Electrical Characteristics (continued) at $V_B = V_{BCP} = 3.6\text{ V}$, $V_{LED} = 4.5\text{ V}$, $V_{DD} = 1.85\text{ V}$

Note) $T_a = 25^\circ\text{C} \pm 2^\circ\text{C}$ unless otherwise specified.

B No.	Parameter	Symbol	Conditions	Limits			Unit	Notes
				Min	Typ	Max		
LDOCNT								
58	High-level input voltage range	V_{IH3}	High-level recognition voltage of LDOCNT	1.6	—	$V_B + 0.3$	V	—
59	Low-level input voltage range	V_{IL3}	Low-level recognition voltage of LDOCNT	-0.3	—	0.4	V	—
60	High-level input current	I_{IH2}	$V_{P26} = 3.6\text{ V}$ $I_{IH2} = I_{P26}$	—	0	1	μA	—
61	Low-level input current	I_{IL2}	$V_{P26} = 0\text{ V}$ $I_{IL2} = I_{P26}$	—	0	1	μA	—
NRESET								
62	High-level input voltage range	V_{IH4}	High-level recognition voltage of NRESET	1.5	—	$V_B + 0.3$	V	—
63	Low-level input voltage range	V_{IL4}	Low-level recognition voltage of NRESET	-0.3	—	0.6	V	—
64	High-level input current	I_{IH3}	$V_{P54} = 3.6\text{ V}$ $I_{IH3} = I_{P54}$	—	0	1	μA	—
65	Low-level input current	I_{IL3}	$V_{P54} = 0\text{ V}$ $I_{IL3} = I_{P54}$	—	0	1	μA	—
INT								
66	ON resistance	RINTON	$I_{P55} = 5\text{ mA}$ $R_{INTON} = V_{P55} / 5\text{ mA}$	—	—	50	Ω	—

■ Electrical Characteristics (continued) at $V_B = V_{BCP} = 3.6\text{ V}$, $V_{LED} = 4.5\text{ V}$, $V_{DD} = 1.85\text{ V}$

Note) $T_a = 25^\circ\text{C} \pm 2^\circ\text{C}$ unless otherwise specified.

B No.	Parameter	Symbol	Conditions	Limits			Unit	Notes
				Min	Typ	Max		
I ² C I/F								
67	High-level input voltage	V _{IH5}	High-level recognition voltage of SDA, SCL	$0.7 \times V_{DD}$	—	$V_{DD} + 0.5, 3.2$	V	—
68	Low-level input voltage	V _{IL5}	Low-level recognition voltage of SDA, SCL	-0.5	—	$0.3 \times V_{DD}$	V	—
69	Low-level output voltage 1	V _{OL3}	$V_{DD} > 2\text{ V}$ IP50 = 3 mA	0	—	0.4	V	—
70	Low-level output voltage 2	V _{OL4}	$V_{DD} < 2\text{ V}$ IP50 = 3 mA	0	—	$0.2 \times V_{DD}$	V	—
71	Input current each I/O pin	i _i	VP49, 50 = 0.1 V to 2.88 V	-10	0	10	μA	—
72	SCL clock frequency	f _{SCL}	—	0	—	400	kHz	—
Light Intensity Control								
73	PD1 pin ON resistance	RPD1ON	—	—	—	100	Ω	—
74	PD3 pin ON resistance	RPD3ON	—	—	—	50	Ω	—
75	A/D converted value (1)	AD1	VP19 = VLPS2 / 256 Read value of the register, ADC_DATA[9:2]	—	1	5	LSB	—
76	A/D converted value (2)	AD2	VP19 = VLPS2 × 128 / 256 Read value of the register, ADC_DATA[9:2]	124	128	132	LSB	—
77	A/D converted value (3)	AD3	VP19 = VLPS2 × 255 / 256 Read value of the register, ADC_DATA[9:2]	251	255	—	LSB	—

- Technical Data
- $P_D - T_a$ diagram

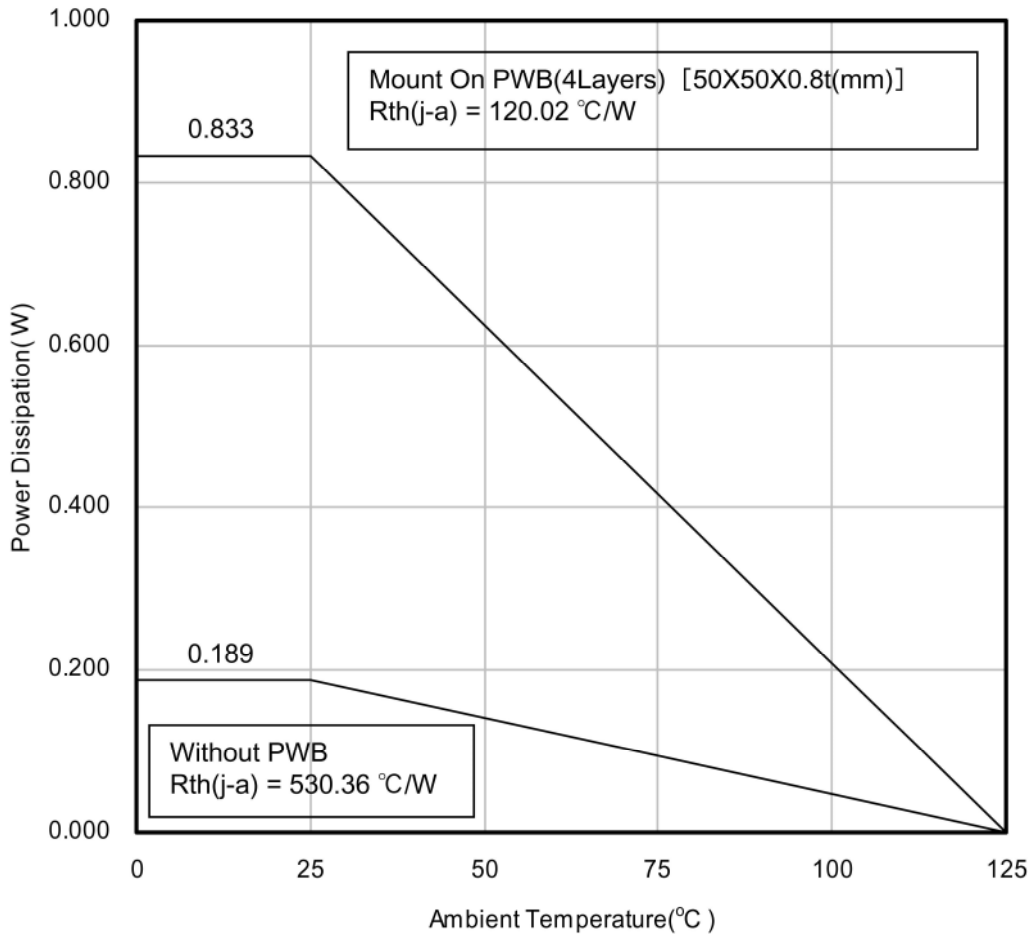

■ Usage Notes**• Special attention and precaution in using**

1. This IC is intended to be used for general electronic equipment.
Consult our sales staff in advance for information on the following applications:
 - Special applications in which exceptional quality and reliability are required, or if the failure or malfunction of this IC may directly jeopardize life or harm the human body.
 - Any applications other than the standard applications intended.
 - (1) Space appliance (such as artificial satellite, and rocket)
 - (2) Traffic control equipment (such as for automobile, airplane, train, and ship)
 - (3) Medical equipment for life support
 - (4) Submarine transponder
 - (5) Control equipment for power plant
 - (6) Disaster prevention and security device
 - (7) Weapon
 - (8) Others : Applications of which reliability equivalent to (1) to (7) is required
2. Pay attention to the direction of LSI. When mounting it in the wrong direction onto the PCB (printed-circuit-board), it might smoke or ignite.
3. Pay attention in the PCB (printed-circuit-board) pattern layout in order to prevent damage due to short circuit between pins. In addition, refer to the Pin Description for the pin configuration.
4. Perform a visual inspection on the PCB before applying power, otherwise damage might happen due to problems such as a solder-bridge between the pins of the semiconductor device. Also, perform a full technical verification on the assembly quality, because the same damage possibly can happen due to conductive substances, such as solder ball, that adhere to the LSI during transportation.
5. Take notice in the use of this product that it might break or occasionally smoke when an abnormal state occurs such as output pin- V_{CC} short (Power supply fault), output pin-GND short (Ground fault), or output-to-output-pin short (load short) .
And, safety measures such as an installation of fuses are recommended because the extent of the above-mentioned damage and smoke emission will depend on the current capability of the power supply.
6. When designing your equipment, comply with the range of absolute maximum rating and the guaranteed operating conditions (operating power supply voltage and operating environment etc.). Especially, please be careful not to exceed the range of absolute maximum rating on the transient state, such as power-on, power-off and mode-switching. Otherwise, we will not be liable for any defect which may arise later in your equipment.
Even when the products are used within the guaranteed values, take into the consideration of incidence of break down and failure mode, possible to occur to semiconductor products. Measures on the systems such as redundant design, arresting the spread of fire or preventing glitch are recommended in order to prevent physical injury, fire, social damages, for example, by using the products.
7. When using the LSI for new models, verify the safety including the long-term reliability for each product.
8. When the application system is designed by using this LSI, be sure to confirm notes in this book.
Be sure to read the notes to descriptions and the usage notes in the book.
9. Due to unshielded structure of this IC, under exposure of light, function and characteristic of the product cannot be guaranteed.
During normal operation or even under testing condition, please ensure that IC is not exposed to light.
10. Basically, chip surface is ground potential. Please design to ensure no contact between chip surface and metal shielding.

Request for your special attention and precautions in using the technical information and semiconductors described in this book

- (1) If any of the products or technical information described in this book is to be exported or provided to non-residents, the laws and regulations of the exporting country, especially, those with regard to security export control, must be observed.
- (2) The technical information described in this book is intended only to show the main characteristics and application circuit examples of the products. No license is granted in and to any intellectual property right or other right owned by Panasonic Corporation or any other company. Therefore, no responsibility is assumed by our company as to the infringement upon any such right owned by any other company which may arise as a result of the use of technical information described in this book.
- (3) The products described in this book are intended to be used for general applications (such as office equipment, communications equipment, measuring instruments and household appliances), or for specific applications as expressly stated in this book.
Consult our sales staff in advance for information on the following applications:
 - Special applications (such as for airplanes, aerospace, automotive equipment, traffic signaling equipment, combustion equipment, life support systems and safety devices) in which exceptional quality and reliability are required, or if the failure or malfunction of the products may directly jeopardize life or harm the human body.It is to be understood that our company shall not be held responsible for any damage incurred as a result of or in connection with your using the products described in this book for any special application, unless our company agrees to your using the products in this book for any special application.
- (4) The products and product specifications described in this book are subject to change without notice for modification and/or improvement. At the final stage of your design, purchasing, or use of the products, therefore, ask for the most up-to-date Product Standards in advance to make sure that the latest specifications satisfy your requirements.
- (5) When designing your equipment, comply with the range of absolute maximum rating and the guaranteed operating conditions (operating power supply voltage and operating environment etc.). Especially, please be careful not to exceed the range of absolute maximum rating on the transient state, such as power-on, power-off and mode-switching. Otherwise, we will not be liable for any defect which may arise later in your equipment.
Even when the products are used within the guaranteed values, take into the consideration of incidence of break down and failure mode, possible to occur to semiconductor products. Measures on the systems such as redundant design, arresting the spread of fire or preventing glitch are recommended in order to prevent physical injury, fire, social damages, for example, by using the products.
- (6) Comply with the instructions for use in order to prevent breakdown and characteristics change due to external factors (ESD, EOS, thermal stress and mechanical stress) at the time of handling, mounting or at customer's process. When using products for which damp-proof packing is required, satisfy the conditions, such as shelf life and the elapsed time since first opening the packages.
- (7) This book may be not reprinted or reproduced whether wholly or partially, without the prior written permission of our company.