

Grooving and Parting-off - Toolholders

Tool Block 150.10-...-20/25 and HSS-blade 150.10-20/25 for Parting-off

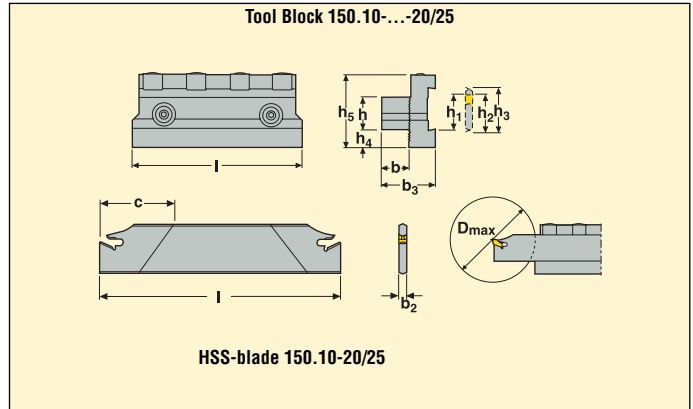

• Inserts, please see pages 244-245



Part No.	Dimensions in mm												KG	
	h	b	h ₁	h ₂	h ₃	h ₄	h ₅	l	b ₂	b ₃	D _{max}	c		
150.10 -1616-20	16	16	20	21,4	26	12	42,1	100	-	35,75	-	-	0,7	-
	20	20	20	21,4	26	8	42,1	100	-	39,75	-	-	0,8	-
150.10 -2520-25	25	20	25	25	32	12,5	54	125	-	39,75	-	-	1,2	-
	25	25	25	25	32	12,5	54	125	-	44,75	-	-	1,4	-
	32	32	25	25	32	5,5	54	125	-	51,75	-	-	1,7	-
150.10 -20-2	-	-	-	-	-	-	-	120	1,80	-	35	25	0,1	150.10-2..
	-	-	-	-	-	-	-	120	2,00	-	35	25	0,1	150.10-2.5..
	-	-	-	-	-	-	-	120	2,40	-	90	-	0,1	150.10-3..
	-	-	-	-	-	-	-	120	3,40	-	100	-	0,1	150.10-4..
	-	-	-	-	-	-	-	120	4,40	-	120	-	0,1	150.10-5..
	-	-	-	-	-	-	-	120	5,65	-	120	-	0,1	150.10-6..
150.10 -25-3	-	-	-	-	-	-	-	150	2,40	-	120	-	0,1	150.10-3..
	-	-	-	-	-	-	-	150	3,40	-	140	-	0,1	150.10-4..
	-	-	-	-	-	-	-	150	4,40	-	160	-	0,1	150.10-5..
	-	-	-	-	-	-	-	150	5,65	-	160	-	0,2	150.10-6..

Spare Parts, Parts included in delivery

Toolholder/ Insert dimension	Wedge	Wedge screw	Screw/ Key	Key for change of insert*
-1616-20	150.10-646	150.10-650	MF6S 6x20	150.10-159
-2020-20	150.10-646	150.10-650	MF6S 6x25	150.10-159
-25	150.10-646	150.10-650	MF6S 6x25	150.10-159