



Technical Data Sheet

Alpha 50



Alpha 50 is a compact multifunction instrument with touch screen LCD utility which measures important electrical parameters in 3 phase and single phase Network & replaces the multiple analog panel meters.

Special Features

- True RMS Measurement
- Onsite Programmable
- Low Back Depth
- Phase Reversal Indication
- Touch screen graphics LCD
- RS-485, Limit or Pulse Output, analog output

Application

Alpha 50 measures important electrical parameters in 3 phase and single phase Network & replaces the multiple analog panel meters. It measures electrical parameters like AC current, Voltage, frequency, active energy import & active energy export, Current Demand, kW Demand, kVA Demand and Max Current Demand, Max kW Demand and Max kVA Demand. The instrument has optional output as one pulse output or two pulse output for energy measurement.

Product Features

Touch screen graphics LCD	Alpha 50 has touch sensible color graphics LCD display with resolution of 320 x 240.	Phaser Diagram	Pictorial representation of all 3 Phases (Voltage & Current) in terms of vectors.
On site programmable PT/CT ratios	It is possible to program primary of external potential Transformer (PT), primary of external Current Transformer (CT) on site locally by entering into Programming mode or remotely via MODBUS (RS-485)	Wave Form	Pictorial representation of all 3 phases Current & voltage in terms of sinusoidal waveform.
User selectable CT Secondary A/1A	The secondary of external Current Transformer (CT) can be programmed on site to either 5A or 1A locally by entering into Programming mode or remotely via MODBUS (RS-485)	Total Harmonic Distortion (THD)	The instrument can measure per phase (%) THD of voltage and (%) THD of current.
User selectable PT Secondary	The secondary of external potential Transformer (PT) can be programmed on site locally by entering into Programming mode or remotely via MODBUS (RS-485)	Energy Count storage	In case of power failure, the instrument memorizes the last energy count. Every 40 sec, the instrument updates the energy counter in the nonvolatile memory.
User selectable 3 phase 3W or 4W unbalanced network	User can program on site the network connection as either 3 Phase 3 Wire or 4 Wire locally by entering into Programming mode or remotely via MODBUS (RS-485). For single phase applications, single phase version is available.	Programmable Energy format & Energy rollover count	Customer can assign the format for energy display on MODBUS (RS-485) in terms of W, kW or MW. Additional to this, customer can also set a rollover count from 7 to 14 digits depending on the energy format.
Low back depth	The instrument has very low back depth (behind the panel) of less than 80 mm in spite of optional features like pulse output	Hour Run, ON Hour, Number of Interruptions	Hour run records the number of hours load is connected. ON Hour is the period for which the auxiliary supply is ON. Number of Interruptions indicates the number of times the Auxiliary Supply was interrupted.
Onsite selection of Auto scroll / Fixed Screen	User can set the display in auto scrolling mode or fixed screen mode can be programmed locally by entering into Programming mode or remotely via MODBUS (RS485).	Optional MODBUS (RS485) Output	The optional ModBus output enables the instrument to transmit all the measured parameters over standard MODBUS (RS-485).
Phase reversal indication	The instrument can detect wrong phase sequence or failure of one of the input voltages and displays "phase" error message.	User Assignable Registers for MODBUS	Customer can assign MODBUS register address as per his need for faster response time.
Energy measurement (Import and Export)	Active energy (kWh), Reactive energy (kVAh), Apparent energy (kVAh) & Ampere Hour (kAh). Any of the parameters can be freely assigned to 2 optional pulse outputs.	Optional Pulse Output (1 or 2 Relay output) / Limit switch	The instrument can be programmed as Pulse output or Limit Switch.
True RMS measurement	The instrument measures distorted waveform up to 15th Harmonic.	Pulse Output	The optional pulse output is a potential free, very fast acting relay contact which can be used to drive an external mechanical counter for energy measurement.
User selectable Low Current suppression (below 30 mA)	User can suppress the readings below 30 mA in the current measurement by onsite programming if required.	Configuration of the Instrument via MODBUS	The instrument settings can be configured locally by entering into Programming mode or remotely via MODBUS (RS485) Note: The MODBUS communication parameters can only be set locally by entering into the Programming mode.

Product Features

Min Max storage of parameters possible	The instrument stores minimum and maximum values for System Voltage and System Current. Every 40 sec minimum and maximum readings are updated.
Number of parameters measured : more than 46	The instrument measures more than 46 electrical parameters of 3 Phase network.
Parameter Screen recall	In case of power failure, the instrument memorizes the last displayed screen. The displayed screen will get memorized only if user keeps this screen for minimum 40 sec duration before power failure for fixed screen mode.

Limit switch	The instrument will trip the one or two relays if the programmed parameter exceeds the programmed High & Low Limits.
Optional Analog Outputs (1 or 2 Outputs)	1 or 2 Analog outputs can be programmed from a list of input parameters.
Enclosure Protection for dust and water	conforms to IP 54 (front face) as per IEC60529
Compliance to International Safety standards	Compliance to International Safety standard IEC 61010-1- 2001
EMC Compatibility	Compliance to International standard IEC 61326

Technical Specifications

Reference conditions for Accuracy	
Reference temperature	23°C +/- 2°C
Input waveform	Sinusoidal (distortion factor 0.005)
Input frequency	50 or 60 Hz ±2%
Auxiliary supply voltage	Rated Value ±1%
Auxiliary supply frequency	Rated Value ±1%
Voltage Range	50... 100% of Nominal Value. 60... 100% of Nominal Value for THD.
Current Range	10... 100% of Nominal Value. 20... 100% of Nominal Value for THD.
Power	Cos phi / sin phi = 1 for Active / Reactive Power & Energy. 10... 100% of Nominal Current & 50... 100% of Nominal Voltage.
Power Factor / Phase Angle	40... 100% of Nominal Current & 50... 100% of Nominal Voltage.

Accuracy	
Voltage	± 0.5% of range
Current	± 0.5% of range
Frequency	± 0.15% of mid frequency
Active Power	± 0.5% of range
Re-Active Power	± 0.5% of range
Apparent Power	± 0.5% of range
Active energy (kWh)	± 0.5% of range
Re Active energy (kVArh)	± 0.5% of range
Apparent energy (kVAh)	± 0.5% of range
Accuracy of Analog Output	1 % of Output end value
Power Factor	±1% of Unity
Angle	±1% of range
Total Harmonic Distortion	±1%

Electrical Connections

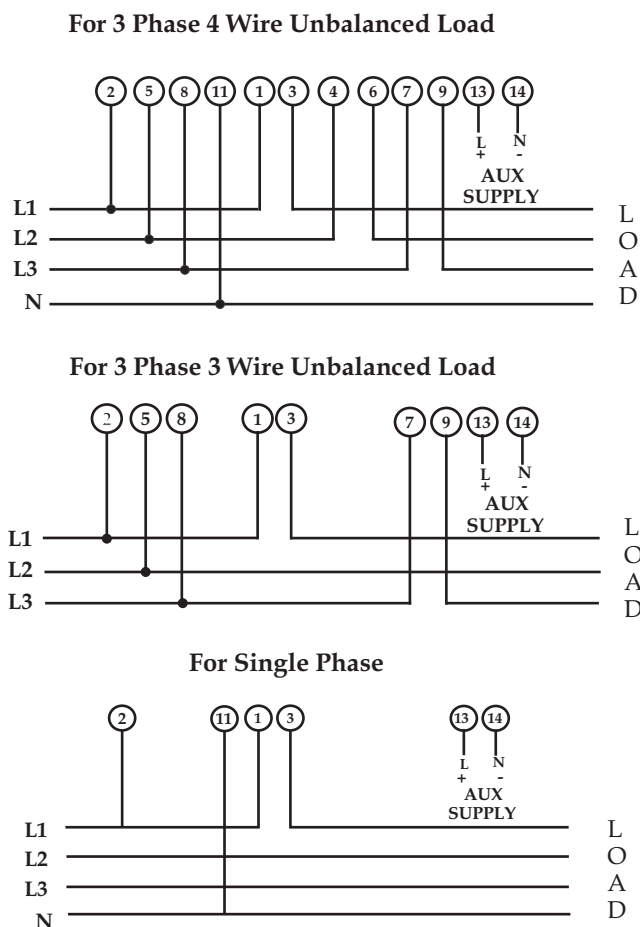

It is recommended that the wires used for connections to the instrument should have lugs soldered at the end. That is, the connections should be made with Lugged wires for secure connections. The Maximum diameter of the lug should be 7.0 mm and maximum thickness 3.5 mm. Permissible cross section of the connection wires: $\leq 4.0 \text{ mm}^2$ single wire or $2 \times 2.5 \text{ mm}^2$ fine wire.

Technical Specifications

Input Voltage	
Nominal input voltage (AC RMS)	Phase -Neutral 63.5 / 133 / 239.6 / 254 VL-N Line-Line 110/230/415/ 440 VL-L
System PT primary values	100VLL to 692kVLL programmable on site.
Max continuous input voltage	120% of rated value

Input Current	
Nominal input current	5A AC RMS.
System CT secondary values	1A & 5A programmable on site.
System CT primary values	From 1A up to 9999A (for 1 or 5 Amp)
Max continuous input current	120% of rated value

Auxiliary Supply	
ACDC Auxiliary Supply	100V... 250 VAC DC +/- 10%
DC Auxiliary Supply	12.....48 VDC +/- 10%
AC Auxiliary supply frequency range	45 to 66 Hz

Overload Withstand	
Voltage	2 x rated value for 1 second, repeated 10 times at 10 second intervals
Current	20x rated value for 1 second, repeated 5 times at 5 min

Operating Measuring Ranges	
Voltage	5... 120% of rated value
Current	5 ... 120% of rated value
Frequency	40...70 Hz
Power Factor	0.5 Lag ... 1... 0.8 Lead

Influence of Variations	
Temperature coefficient	0.025%/°C for Voltage (50... 120% of rated value) and 0.05%/°C for Current (10... 120% of rated value)

Environmental	
Operating temperature	-20 to +70°C
Storage temperature	-30 to +80°C
Relative humidity	0... 95% non condensing
Warm up time	Minimum 3 minute
Shock	15g in 3 planes
Vibration	10... 55 Hz, 0.15mm amplitude

Dimensions

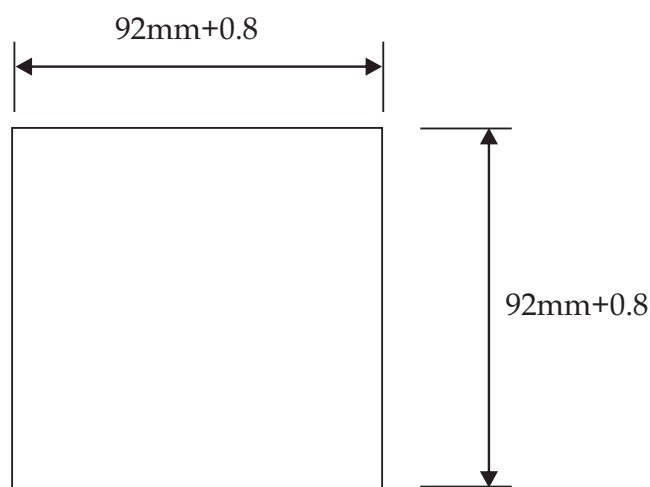
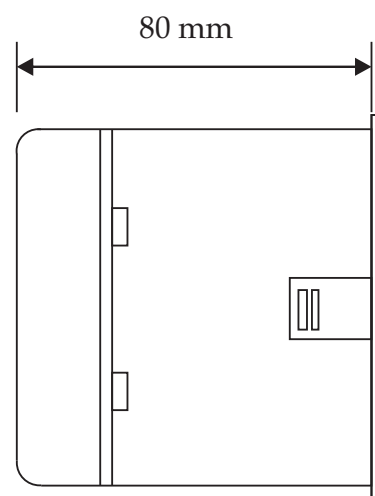
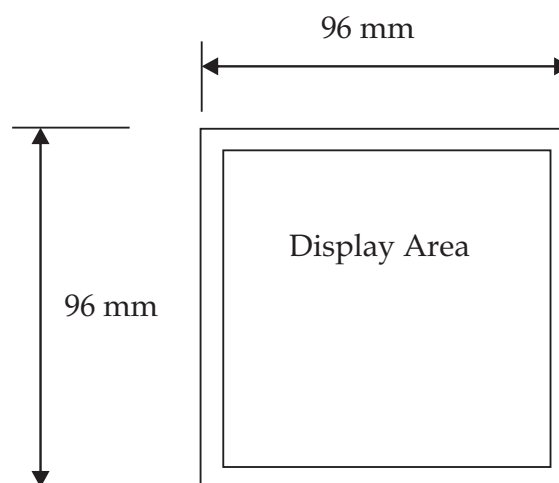

Panel Cutout

Technical Specifications

Display update rate	
Response time to step input	1 sec approx.
Applicable Standards	
EMC	IEC 61326
Immunity	IEC 61000-4-3. 10V/m min - Level 3 industrial low level
Safety	IEC 61010-1-2001 , Permanently connected use
IP for water & dust	IEC60529
Pollution degree	2
Installation category	III
High Voltage Test	2.2 kV AC, 50Hz for 1 minute between all electrical circuits
VA Burden	
Nominal input voltage burden	< 0.2 VA approx. per phase
Nominal input current burden	< 0.6 VA approx. per phase
Auxillary Supply burden	
For VAC Aux.	< 6.5 VA approx.
For DC Aux.	< 3 W approx.

Ampere Hour

Default pulse rate divisor	CT secondary = 1A Max pulse rate 3600 pulses/Ah * CT secondary = 5A Max pulse rate 720 pulses/Ah
Other Pulse rate Divisors (applicable only when Energy on MODBUS (RS-485) is in W)	
10	CT secondary = 1A Max pulse rate 3600 pulses/10Ah * CT secondary = 5A Max pulse rate 720 pulses/10Ah
100	CT secondary = 1A Max pulse rate 3600 pulses/100Ah * CT secondary = 5A Max pulse rate 720 pulses/100Ah
1000	CT secondary = 1A Max pulse rate 3600 pulses/1000Ah * CT secondary = 5A Max pulse rate 720 pulses/1000Ah
Pulse duration	60 ms, 100 ms or 200 ms
*No. of Pulses = $\frac{\text{Maximum Pulses}}{\text{CT Ratio}}$ Where, CT Ratio = (CT primary/ CT Secondary)	

Energy (can be programmed for different energy parameters simultaneously)

Energy (can be programmed for different energy parameters simultaneously)			
Relay contact	(1NO+1NC)		
Switching Voltage & current for Relay	240 VDC ,5 A		
Default pulse rate divisor			
1 per Wh (up to 3600W)	1 per kWh (up to 3600kWh)	1 per MWh (above 3600kW)	
Other Pulse rate divisors (applicable only when Energy on RS-485 is in W)			
10	1 per 10 Wh (up to 3600W)	1 per 10 kWh (up to 3600kWh)	1 per 10 MWh (above 3600kW)
100	1 per 100 Wh (up to 3600W)	1 per 100 kWh (up to 3600kWh)	1 per 100 MWh (above 3600kW)
1000	1 per 1000 Wh (up to 3600W)	1 per 1000 kWh (up to 3600kWh)	1 per 1000 MWh (above 3600kW)
Pulse Duration 60 ms, 100 ms, 200 ms Above options are also applicable to Apparent and Reactive Energy.			

Limit Output Option

Limit can be assigned to different measured parameters. It can be configured in one of the four modes given below.	
1)	Hi alarm & Energized Relay
2)	Hi alarm & De-energized Relay
3)	Lo alarm & Energized Relay
4)	Lo alarm & De-energized Relay
With user selectable Trip point, Hysteresis, Energizing delay and De-energizing delay.	

PT Secondary Ranges for Various Input Voltage

Input Voltage	PT Secondary Settable Range
110V L-L (63.5V L-N)	100V - 120V L-L (57V - 69V L-N)
230V L-L (133V L-N)	121V - 239V L-L (70V - 139V L-N)
415V L-L (239.6V L-N)	240V - 480V L-L (140V - 277V L-N)

Electrical Parameters

Sr No	Displayed Parameters	3 Phase 4Wire	3Phase 3Wire	Single Phase 2W
1.	System Volts	✓	✓	✓
2.	System Current	✓	✓	✓
3.	Volts L1 - N	✓	✗	✗
4.	Volts L2 - N	✓	✗	✗
5.	Volts L3 - N	✓	✗	✗
6.	Volts L1 - L2	✓	✓	✗
7.	Volts L2 - L3	✓	✓	✗
8.	Volts L3 - L1	✓	✓	✗
9.	Current L1	✓	✓	✗
10.	Current L2	✓	✓	✗
11.	Current L3	✓	✓	✗
12.	Neutral Current	✓	✗	✗
13.	Frequency	✓	✓	✓
14.	System Active Power (kW)	✓	✓	✓
15.	Active Power L1 (kW)	✓	✗	✗
16.	Active Power L2 (kW)	✓	✗	✗
17.	Active Power L3 (kW)	✓	✗	✗
18.	System Re-active Power (kVAR)	✓	✓	✓
19.	Re-active Power L1 (kVAR)	✓	✗	✗
20.	Re-active Power L2 (kVAR)	✓	✗	✗
21.	Re-active Power L3 (kVAR)	✓	✗	✗
22.	System Apparent Power (kVA)	✓	✓	✓
23.	Apparent Power L1 (kVA)	✓	✗	✗
24.	Apparent Power L2 (kVA)	✓	✗	✗
25.	Apparent Power L3 (kVA)	✓	✗	✗
26.	System Power Factor	✓	✓	✓
27.	Power Factor L1	✓	✗	✗
28.	Power Factor L2	✓	✗	✗
29.	Power Factor L3	✓	✗	✗
30.	Phase Angle L1	✓	✗	✓
31.	Phase Angle L2	✓	✗	✗
32.	Phase Angle L3	✓	✗	✗
33.	Import kWh (8 digit resolution)	✓	✓	✓
34.	Export kWh (8 digit resolution)	✓	✓	✓
35.	Import kVARh (8 digit resolution)	✓	✓	✓
36.	Export kVARh (8 digit resolution)	✓	✓	✓
37.	kVAh (8 digit resolution)	✓	✓	✓
38.	KAh (8 digit resolution)	✓	✓	✓
39.	Current Demand	✓	✓	✓
40.	KVA Demand	✓	✓	✓
41.	KW Import Demand	✓	✓	✓
42.	KW Export Demand	✓	✓	✓
43.	Max Current Demand	✓	✓	✓
44.	Max KVA Demand	✓	✓	✓
45.	Max KW Import Demand	✓	✓	✓
46.	Max KW Export Demand	✓	✓	✓
47.	Run Hour	✓	✓	✓
48.	On Hour	✓	✓	✓
49.	Number of Interruptions	✓	✓	✓
50.	Phase Reversal Indication	✓	✗	✗
51.	Phaser Diagram (Pictorial Representation)	✓	✗	✓
52.	VA waveform (Pictorial Representation)	✓	✗	✓
53.	THD Volts L1-N	✓	✗	✗

✓ : Available ✗ : Not Available

Electrical Parameters

Sr No	Displayed Parameters	3 Phase 4Wire	3Phase 3Wire	Single Phase 2W
54.	THD Volts L2-N	✓	✗	✗
55.	THD Volts L3-N	✓	✗	✗
56.	THD Volts L1-L2	✗	✓	✗
57.	THD Volts L2-L3	✗	✓	✗
58.	THD Volts L3-L1	✗	✓	✗
59.	THD Current L1	✓	✓	✗
60.	THD Current L2	✓	✓	✗
61.	THD Current L3	✓	✓	✗
62.	THD Voltage Mean	✓	✓	✓
63.	THD Current Mean	✓	✓	✓

✓ : Available ✗ : Not Available

Ordering Information

Product Code	AP50-	X	X	X	X	X	X	000000
System Type	3 Ph. (PR. 3W or 4W)	3						
	1 Ph.	1						
Input Voltage / Current	110V L-N 1/5A		1					
	230V L-N 1/5A		3					
	110V L-L 1/5A		6					
	220V L-L 1/5A		9					
	230V L-L 1/5A		A					
	380V L-L 1/5A		C					
	400V L-L 1/5A		D					
	415V L-L 1/5A		E					
	440V L-L 1/5A		F					
Power Supply	100-250V AC/DC +/- 10%				U			
	12V-48V DC +/- 10%				D			
RS 485	With RS 485					R		
	Without RS 485					Z		
Pulse Output	1 Pulse output						S	
	2 Pulse output						D	
	Pulse O/P not used						Z	
Analog Output	2 outputs (0 - 1mA)							1
	2 outputs (4 - 20 mA)							2
	Analog Outputs option not used							Z



sifam tinsley
PRECISION INSTRUMENTATION

Sifam Tinsley Instrumentation Inc.
3105, Creekside Village Drive,
Suite No. 801, Kennesaw,
Georgia 30144 (USA)
E-mail Id : psk@sifamtinsley.com
Web : www.sifamtinsley.com
Contact No. : +1 404 736 4903

Sifam Tinsley Instrumentation Ltd
Unit 1 Warner Drive,
Springwood Industrial Estate
Braintree, Essex, UK, CM72YW
E-mail: sales@sifamtinsley.com
Web: www.sifamtinsley.com/uk
Contact: +44(0)1803615139