

REV.	MODIFICATION.	DATE	DRN
01	Production release	04/09/09	MT
02	CO2010839	19/10/09	MT

UL94 V-2 NYLON 6/6, RMS-01 COLOUR: NATURAL	UL94 V-0 NYLON 6/6, RMS-19 COLOUR: NATURAL	"A" REF	"B" REF	"C" REF	"D" REF	FIGURE	
OFNS-13-187-01	OFNS-13-187-19	26.8[1.06]	21.2[.83]	19[.75]	28.2[1.11]	1	
OFNS-13-312-01	OFNS-13-312-19					2	
OFNS-13-250-01	OFNS-13-250-19					4	
OFNS-13-S9.5M-01	OFNS-13-S9.5M-19					5	
OFNSB-13-01A2-RT	OFNSB-13-19A2-RT					32.7[1.29]	6
OFNS-16-187-01	OFNS-16-187-19	34.3[1.35]	28.7[1.13]	25.1[.99]	34.4[1.35]	1	
OFNS-16-312-01	OFNS-16-312-19					2	
OFNS-16-S307-01	OFNS-16-S307-19					3	
OFNS-16-S9.5M-01	OFNS-16-S9.5M-19					5	
OFNSB-16-01A2-RT	OFNSB-16-19A2-RT					38.9[1.53]	6
OFNS-28-S9.5M-01	OFNS-28-S9.5M-19					43[1.69]	35[1.38]

AVAILABLE IN BLACK COLOUR BY SPECIAL ORDER. TO ORDER, ADD "BK" TO THE END OF THE PART NUMBER

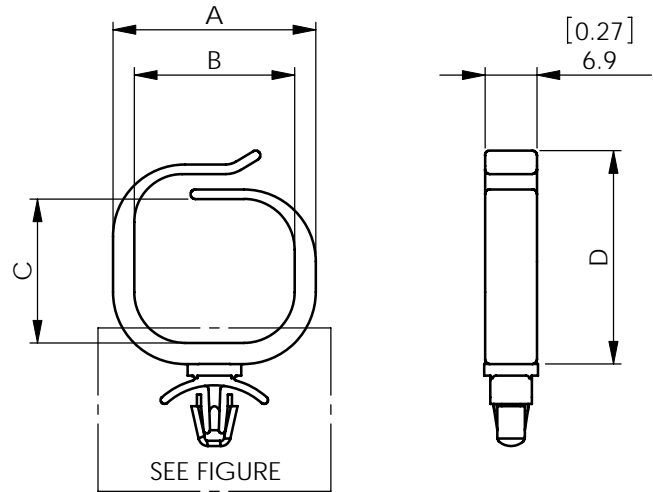

ALTERNATE UNITS FOR REFERENCE ONLY

INFORMATION CONTAINED IN THIS DOCUMENT IS CONFIDENTIAL TO RICHCO INTERNATIONAL Co. Ltd. AND MAY NOT BE DISCLOSED OR REPRODUCED IN WHOLE OR PART WITHOUT THEIR WRITTEN CONSENT.

<b>RICHCO, INC.</b> WWW.RICHCO-INC.COM	ALL DIMENSIONS IN mm GENERAL TOLERANCES ±0.25 UNLESS OTHERWISE STATED 1 DECIMAL PLACE ± 2 DECIMAL PLACES ± ANGULAR ±1°	THIRD ANGLE 
	MATERIAL: SEE TABLE COLOUR: SEE TABLE	

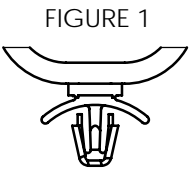

FIGURE 1  
TO SNAP LOCK INTO A  
Ø4.75±0.08[.187±.003] HOLE  
IN A 0.8-2.0[.031-.079]  
THICK PANEL

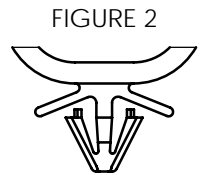

FIGURE 2  
TO SNAP LOCK INTO A  
Ø7.92±0.08[.312±.003] HOLE  
IN A 0.8-1.6[.031-.063]  
THICK PANEL

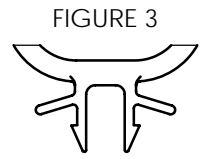

FIGURE 3  
TO SNAP LOCK INTO A  
Ø7.80±0.08[.307±.003] HOLE  
IN A 0.8-2.0[.031-.079]  
THICK PANEL

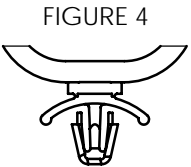

FIGURE 4  
TO SNAP LOCK INTO A  
Ø6.35±0.08[.250±.003] HOLE  
IN A 0.8-2.0[.031-.079]  
THICK PANEL

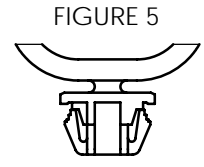

FIGURE 5  
TO SNAP LOCK INTO A  
Ø9.50±0.08[.374±.003] HOLE  
IN A 0.8-2.0[.031-.079]  
THICK PANEL

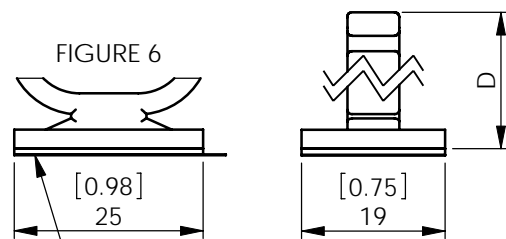

FIGURE 6  
0.8[.03] THICK DOUBLE SIDED  
ADHESIVE TAPE WITH RELEASE  
TAB, RMS-24

DESCRIPTION: OPTICAL FIBER NETWORK SADDLE  
PART No: SEE TABLE

DRG No: 09-089  
PROJECT NUMBER:  
SHEET SIZE A4

DRN MT	DATE 04/09/09	CHKD TC	DATE 04/09/09	SCALE NTS	SHEET No. 1 OF 1
-----------	------------------	------------	------------------	--------------	---------------------