

Product Data Sheet 4600 Z-881

ebmpapst

The engineer's choice



4600 Z-881

INDEX

1 General 3

2 Mechanics 3

2.1 GENERAL..... 3

2.2 CONNECTIONS 4

3 Operating Data 5

3.1 ELECTRICAL OPERATING DATA 5

3.2 OPERATING DATA - ELECTRICAL INTERFACE - OUTPUT..... 6

3.3 ELECTRICAL FEATURES 6

3.4 AERODYNAMICS 6

3.5 SOUND DATA 7

4 Environment..... 7

4.1 GENERAL..... 7

4.2 CLIMATIC REQUIREMENTS*)..... 7

5 Safety 8

5.1 ELECTRICAL SAFETY 8

5.2 APPROVAL TESTS 8

6 Reliability..... 8

6.1 GENERAL..... 8

1 General

| | |
|-------------------------------------|------------------------|
| Fan type | Fan |
| Rotating direction looking at rotor | Clockwise |
| Airflow direction | Air outlet over struts |
| Bearing system | Sleeve bearing |
| Mounting position - shaft | Any |
| Balancing grade | 2,5 |

2 Mechanics**2.1 General**

| | | |
|---|---|--|
| Width | 119,0 mm | |
| Height | 119,0 mm | |
| Depth | 38,0 mm | |
| Diameter | 0,0 mm | |
| Mass | 0,540 kg | |
| Housing material | Metal | |
| Impeller material | Metal | |
| Max. torque when mounted across both mounting flanges | wire outlet corner: 120 Ncm remaining corners: 350 Ncm | |
| Screw size | ISO 4762 - M4 degreased, without an additional brace and without washer | |

2.2 Connections

| | | |
|-----------------------|-------------|--|
| Electrical connection | Plug | |
| Lead wire length | See drawing | |
| Tolerance | | |
| Tube length | See drawing | |
| Tolerance | | |
| Wire size (AWG) | | |
| Insulation diameter | | |
| Plug | See drawing | |
| Contact | See drawing | |

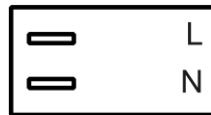

3 Operating Data

3.1 Electrical Operating Data

Measurement conditions: Normal air density = 1,2 kg/m³; Temperature 23°C +/- 3°C; Motor axis horizontal; warm-up time before measuring 5 minutes (unless otherwise specified).
In the intake and outlet area should not be any solid obstruction within 0,5 m.

$\Delta p = 0$: corresp. to free air flow (see section 3.4)

I: corresp. to RMS line current

| Features | Condition | Symbol | Values | |
|--------------------------------|----------------|--------|-----------------------|-----------------------|
| Frequency | $\Delta p = 0$ | f | 50 Hz | 60 Hz |
| Nominal voltage Tolerance | $\Delta p = 0$ | U_N | 115 V +- 10 % | 115 V +- 10 % |
| Power consumption Tolerance | $\Delta p = 0$ | P | 19 W +- 10 % | 18 W +- 10 % |
| Speed Tolerance | $\Delta p = 0$ | n | 2.650 1/min +- 3 % | 3.100 1/min +- 3 % |

3.2 Operating Data - Electrical Interface - Output

| | |
|------------|------|
| Tacho type | None |
|------------|------|

3.3 Electrical Features

| | |
|-------------------------|-----------|
| Locked rotor protection | Impedance |
| Locked rotor current at | |

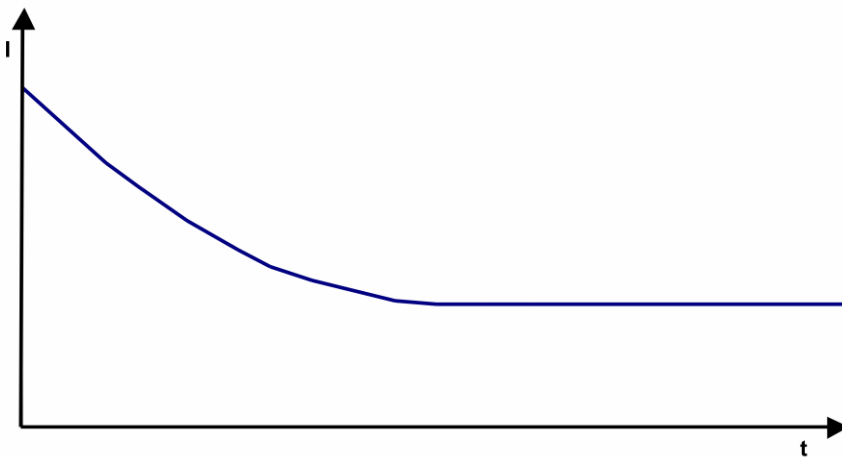

3.4 Aerodynamics

Measurement conditions: Measured with a double chamber intake rig acc. to DIN EN ISO 5801. Normal air density = 1,2 kg/m³; Temperature 23°C +/- 3°C; In the intake and outlet area should not be any solid obstruction within 0,5 m. The information is only valid under the specified test conditions and may be changed by the installation conditions. If there are deviations from the standard test conditions, the characteristic values must be checked under the installed conditions.

a.) Operation condition:
2.650 1/min at free air flow Frequency: 50 Hz

| | |
|---|-------------------------|
| Max. free-air flow ($\Delta p = 0 / \dot{V} = \text{max.}$) | 152,0 m ³ /h |
| Max. static pressure ($\Delta p = \text{max.} / \dot{V} = 0$) | 70 Pa |

b.) Operation condition:
3.100 1/min at free air flow Frequency: 60 Hz

| | |
|---|-------------------------|
| Max. free-air flow ($\Delta p = 0 / \dot{V} = \text{max.}$) | 180,0 m ³ /h |
| Max. static pressure ($\Delta p = \text{max.} / \dot{V} = 0$) | 80 Pa |

3.5 Sound Data

Measurement conditions: Sound pressure level: 1 Meter distance between microphone and the air intake.
 Sound power level: Acc. to DIN 45635 part 38 (ISO 10302)
 Measured in a semianchoic chamber with a background noise level of $L_p(A) < 5 \text{ dB(A)}$
 For further measurement conditions see section 3.4

a.) Operation condition:
 2.650 1/min at free air flow Frequency: 50 Hz

| | | |
|---|--------------------|--|
| Optimal operating point | 136,0 m3/h @ 11 Pa | |
| Sound power level at the optimal operating point | 4,9 bel(A) | |
| Sound pressure level at free air flow, measured in rubber bands | 37,0 dB(A) | |

b.) Operation condition:
 3.100 1/min at free air flow Frequency: 60 Hz

| | | |
|---|--------------------|--|
| Optimal operating point | 154,0 m3/h @ 16 Pa | |
| Sound power level at the optimal operating point | 5,5 bel(A) | |
| Sound pressure level at free air flow, measured in rubber bands | 42,0 dB(A) | |

4 Environment

4.1 General

| | | |
|--|----------------------------------|--|
| Min. permitted ambient temperature TU min. | -10 °C / 50 Hz -10 °C / 60 Hz | |
| Max. permitted ambient temperature TU max. | 50 °C / 50 Hz 60 °C / 60 Hz | |
| Min. permitted storage temperature TL min. | -40 °C | |
| Max. permitted storage temperature TL max. | 80 °C | |

4.2 Climatic Requirements *)

| | | |
|-----------------------|---|--|
| Humidity requirements | humid heat, constant; according to DIN EN 60068-2-78, 14 days | |
| Water exposure | None | |
| Dust requirements | None | |
| Salt fog requirements | None | |

*) Permitted application area:
 The product is intended for use in sheltered rooms with controlled temperature and controlled humidity. Directly exposure to water must be avoided.

Pollution degree 1 (according DIN EN 60664-1)
 There is either no pollution or it occurs only dry, non-conductive pollution. The pollution has no negative impact.

5 Safety

5.1 Electrical Safety

| | |
|--|-------------------|
| Dielectric strength DIN EN 60950 (VDE 0805) and DIN EN 60335 (VDE 0700) A.) Type test Measuring conditions: After 48h of storage at 95% R.H. and 25°C. No arcing or breakdown is allowed! All connections together to ground. | 1000 VAC / 1 Min. |
| B.) Routine test Measuring conditions: At indoor climate. No arcing or breakdown is allowed! All connections together to ground. | 1500 VAC / 1 Sec. |
| Isolation resistance Measuring conditions: After 48h of storage at 95% R.H. and 25°C measured with U=500 VDC for 1 min. | RI > 50 MOhm |
| clearance / creepage distance | 2,0 mm / 1,1 mm |
| Protection class | I |

5.2 Approval Tests

| | | |
|-----|---|---|
| CE | EC Declaration of Conformity | Yes |
| EAC | Eurasian Conformity | Yes |
| UL | Underwriters Laboratories | Yes / UL507, Electric Fans |
| VDE | Association for Electrical, Electronic and Information Technologies | Yes / Approval acc. to EN 60950 (VDE 0805) - Information technology equipment |
| CSA | Canadian Standards Association | Yes / C22.2 No. 113 Fans and Ventilators |
| CCC | China Compulsory Certification | Yes / GB 12350 Safety Requirements for small Power Motors |

The approval tests are observed to:

U approval max.: 115 V / f: 60 Hz @ TU approval max.: 60 °C

6 Reliability

6.1 General

| | | |
|-----------------------------------|--------------------------------------|--|
| Life expectancy L10 at TU = 40 °C | 37.500 h / 50 Hz 40.000 h / 60 Hz | |
| Life expectancy L10 at TU max. | 30.000 h / 50 Hz 25.000 h / 60 Hz | |

Copying of this document and giving it to others and the use or communication of the contents thereof are prohibited. In the event of the report of a patent or the exploitation of a utility model or design.

Schutzzeichen nach DIN ISO 16756 beachten!
 Refer to protection notice DIN ISO 16756

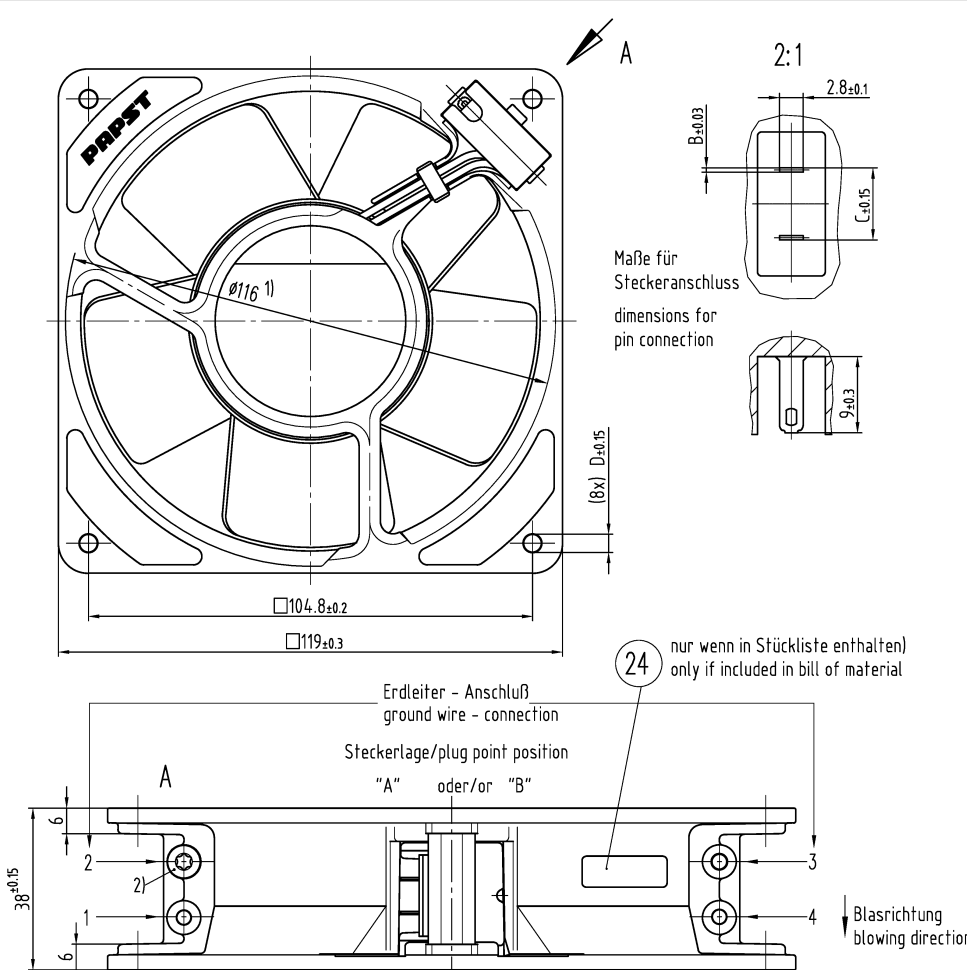

- 1) Maße für Montagewand
 2) Schraube: Duo-Taptite nach DIN 7500, CM 4x8, Torx

Flanschseite
 flangeside

- 1) dimensions for assembly wall
 2) Screw: Duo-Taptite to DIN 7500, CM 4x8, Torx
- axial clearance by
 - ball bearing (K): 0 (with spring compensation)
 - sleeve bearing (G): 0.1 - 0.6
 - sleeve bearing (GF): 0 (with spring compensation)

- Axialspiel bei
 - Kugellagerung (K): 0 (mit Federausgleich)
 - Gleitlagerung (G): 0.1 - 0.6
 - Gleitlagerung (GF): 0 (mit Federausgleich)

| Erzeugnis-Nr. product number | Typ | Logersystem bearing system | Befestigungs- bohrung - ϕ D mounting holes ϕ D | Steckermaße plug dimensions B/C | Steckerlage plug position | Lage des Erdleiter- Anschlusses position the ground wire - connection |
|---------------------------------|-------------|-------------------------------|---|---------------------------------------|------------------------------|---|
| 924 4014 800 | 4656 Z | K | 4.3 | 0.5/8.5 | "A" | 2 |
| 924 4014 801 | 4650 Z | G | 4.3 | 0.5/8.5 | "A" | 2 |
| 924 4014 802 | 4606 Z | K | 4.3 | 0.5/8.5 | "A" | 2 |
| 924 4014 803 | 4600 Z | G | 4.3 | 0.5/8.5 | "A" | 2 |
| 924 4014 828 | 4856 Z | K | 4.3 | 0.5/8.5 | "A" | 2 |
| 924 4014 829 | 4850 Z | G | 4.3 | 0.5/8.5 | "A" | 2 |
| 924 4014 832 | 4806 Z | K | 4.3 | 0.5/8.5 | "A" | 2 |
| 924 4014 833 | 4800 Z | G | 4.3 | 0.5/8.5 | "A" | 2 |
| 924 4014 836 | 4536 Z | K | 4.3 | 0.5/8.5 | "A" | 2 |
| 924 4014 837 | 4530 Z | G | 4.3 | 0.5/8.5 | "A" | 2 |
| 924 4014 840 | 4586 Z | K | 4.3 | 0.5/8.5 | "A" | 2 |
| 924 4014 841 | 4580 Z | G | 4.3 | 0.5/8.5 | "A" | 2 |
| 924 4014 853 | 4656 Z-853 | K | 4.3 | 0.8/8.8 | "A" | 2 |
| 924 4014 854 | 4650 Z-854 | G | 4.3 | 0.8/8.8 | "A" | 2 |
| 924 4014 855 | 4606 Z-855 | K | 4.3 | 0.8/8.8 | "A" | 2 |
| 924 4014 856 | 4600 Z-856 | G | 4.3 | 0.8/8.8 | "A" | 2 |
| 924 4014 857 | 4856 Z-857 | K | 4.3 | 0.8/8.8 | "A" | 2 |
| 924 4014 858 | 4850 Z-858 | G | 4.3 | 0.8/8.8 | "A" | 2 |
| 924 4014 859 | 4806 Z-859 | K | 4.3 | 0.8/8.8 | "A" | 2 |
| 924 4014 860 | 4800 Z-860 | G | 4.3 | 0.8/8.8 | "A" | 2 |
| 924 4014 861 | 4536 Z-861 | K | 4.3 | 0.8/8.8 | "A" | 2 |
| 924 4014 862 | 4530 Z-862 | G | 4.3 | 0.8/8.8 | "A" | 2 |
| 924 4014 863 | 4586 Z-863 | K | 4.3 | 0.8/8.8 | "A" | 2 |
| 924 4014 864 | 4580 Z-864 | G | 4.3 | 0.8/8.8 | "A" | 2 |
| 924 4014 873 | 4656 ZR-873 | K | 4.3 | 0.5/8.5 | "A" | 2 |
| 924 4014 875 | 4656 Z-875 | K | 4.3 | 0.5/8.5 | "A" | 2 |
| 924 4014 876 | 4650 Z-876 | G | 4.3 | 0.8/8.8 | "A" | 2 |
| 924 4014 877 | 4656 Z-877 | K | 4.3 | 0.5/8.5 | "A" | 2 |
| 924 4014 880 | 4606 Z-880 | K | 4.3 | 0.5/8.5 | "A" | 2 |
| 924 4014 881 | 4600 Z-881 | G | 4.3 | 0.8/8.8 | "A" | 2 |
| 924 4014 884 | 4856 ZR-884 | K | 4.3 | 0.5/8.5 | "A" | 2 |
| 924 4014 886 | 4586 ZR-886 | K | 4.3 | 0.5/8.5 | "A" | 2 |
| 924 4014 899 | 4656 Z-899 | K | 4.3 | 0.5/8.5 | "A" | 2+3 |
| 924 4014 901 | 4656 ZR-901 | K | 4.3 | 0.8/8.8 | "A" | 2 |
| 924 4014 905 | 4656 Z-905 | K | 4.3 | 0.8/8.8 | "A" | 2+3 |
| 924 4014 906 | 4606 ZR-906 | K | 4.3 | 0.8/8.8 | "A" | 2 |
| 924 4014 913 | 4536 ZR-913 | K | 4.3 | 0.5/8.5 | "A" | 2 |
| 924 4014 964 | 4626 Z | K | 4.3 | 0.5/8.5 | "A" | 2 |
| 924 4014 967 | 4536 Z-967 | K | 4.3 | 0.5/8.5 | "A" | 2 |
| 924 4014 990 | 4624 ZR | G | 4.3 | 0.5/8.5 | "A" | 2 |
| 924 4014 005 | 4650 Z-005 | G | 4.3 | 0.5/8.5 | "A" | 2 |
| 924 4014 011 | 4606 ZR-011 | K | 4.3 | 0.5/8.5 | "A" | 2 |
| 924 4014 012 | 4586 ZR-012 | K | 4.3 | 0.5/8.5 | "A" | 2 |
| 924 4014 024 | 4586 ZU-024 | K | 4.3 | 0.5/8.5 | "A" | 2 |
| 924 4014 025 | 4656 ZU-025 | K | 4.3 | 0.5/8.5 | "A" | 2 |
| 924 4014 018 | 4856 ZU | K | 4.3 | 0.5/8.5 | "A" | 2 |

| | | | | | | | | | | | |
|--------------------------------------|--|---------------------|--|------------------------|--|----------------------------------|--|-------------------------------------|--|------------------------------------|--|
| SAP-Status/State | | Änd.-Nr./Change-No. | | Aut/CAD-System-Version | | CAD-Umgebung/ CAD-Environment | | Werkstoff/Material: | | Volumen/Volume (mm ³): | |
| | | | | Datum/Date | | Name/Name | | | | Gewicht/Mass (g): | |
| | | Bearb./ Drawn | | Gepr./ Checked | | Freig./ Released | | Artikel/Title | | | |
| Tolerierung/Tolerances: | | | | | | | | | | | |
| Allgemeintoleranzen/Gen. tolerances: | | | | | | | | Zchg.-Nr. / Drawing-No.: | | Ers.f.Zchg. / Replaces: | |
| | | | | | | | | | | | |
| | | | | | | | | | | | |
| | | | | | | | | Dokumenttyp/Type of Document | | Teilnummer (Blatt/Pagel) | |
| | | | | | | | | Index/Index | | Format/Size: | |
| | | | | | | | | ebm-papst St. Georgen GmbH & Co. KG | | Maßstab/Scale | |