

Time control technique

Multifunction relay MK 7850N/200 multitimer

Now with selectable
Plug-in technology



- According to IEC/EN 61 812-1
- 8 functions settable via rotational switch:
 - Delay on energisation (AV)
 - Fleeting on make (EW)
 - Delayed pulse (IE)
 - Flasher, start with pulse (BI)
 - Delay on de-energisation (RV)
 - Pulse forming function (IF)
 - Fleeting on break (AW)
 - Delay on energisation and de-energisation (AV / RV)
- 8 time ranges from 0,02 s to 300 h selectable via rotational switches
- Voltage range AC/DC 12 ... 240 V
- With time interruption / time adding input for all functions
- Adjustment aid for quick setting of long time values
- Suitable for 2-wire proximity sensor control
- 2 changeover contacts, one programmable as instantaneous contact
- LED indicators for operation, contact position and time delay
- Wire connection: also 2 x 1.5 mm² stranded ferruled, or 2 x 2.5 mm² solid DIN 46 228-1/-2/-3/-4
- as option with pluggable terminal blocks for easy exchange of devices
 - with screw terminals
 - or with cage clamp terminals
- 22,5 mm width

Options with pluggable terminal blocks

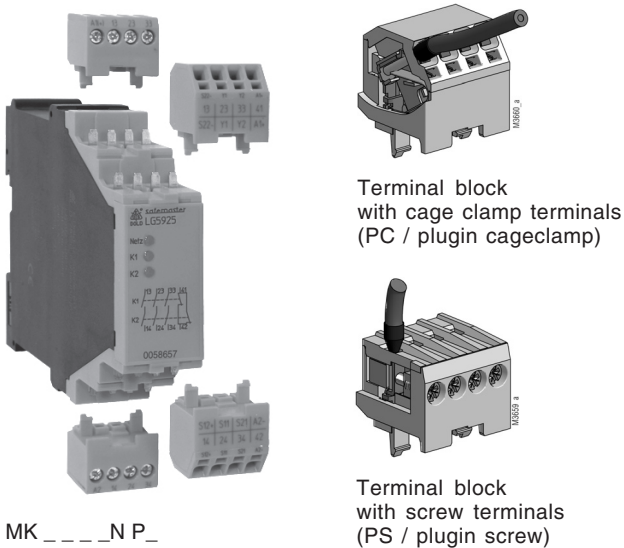

- MK 7850N/500: as MK 7850N/200 but with
- 2 additional functions:
 - Cyclic timer, start with break (TP)
 - Fleeting on make and break (EW / AW)
 - second time setting t_2 for functions
 - Cyclic timer, start with pulse (TI) or break (TP), based on the separate setting of pulse and break time the flasher function can be used as cyclic timer
 - Fleeting on make and break (EW/AW)
 - Delay on energisation and de-energisation (AV / RV)
 - Delay pulse (IE) and setting of pulse length
 - Connection facility for 2 external potentiometers

Approvals and marking



* see variants

Notes

Removing the terminal blocks with cage clamp terminals

1. The unit has to be disconnected.
2. Insert a screwdriver in the side recess of the front plate.
3. Turn the screwdriver to the right and left.
4. Please note that the terminal blocks have to be mounted on the belonging plug in terminations.

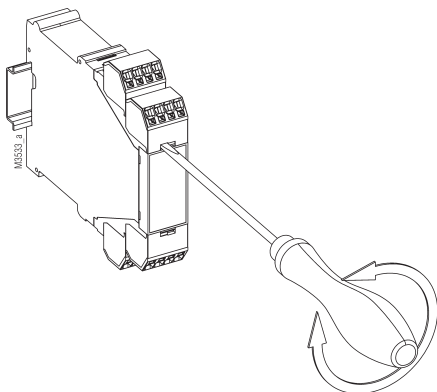

Application

Time-dependent controllers

Indicators

green LED:	on when voltage connected
yellow LED "R/t":	shows status of output relay and time delay:
-Continuously off:	output relay not active;
	no time delay
-Continuously on:	output relay active;
	no time delay
-Flashing (short on, long off)	output relay not active;
	time delay
-Flashing (long on, short off)	output relay active;
	time delay

Function diagram

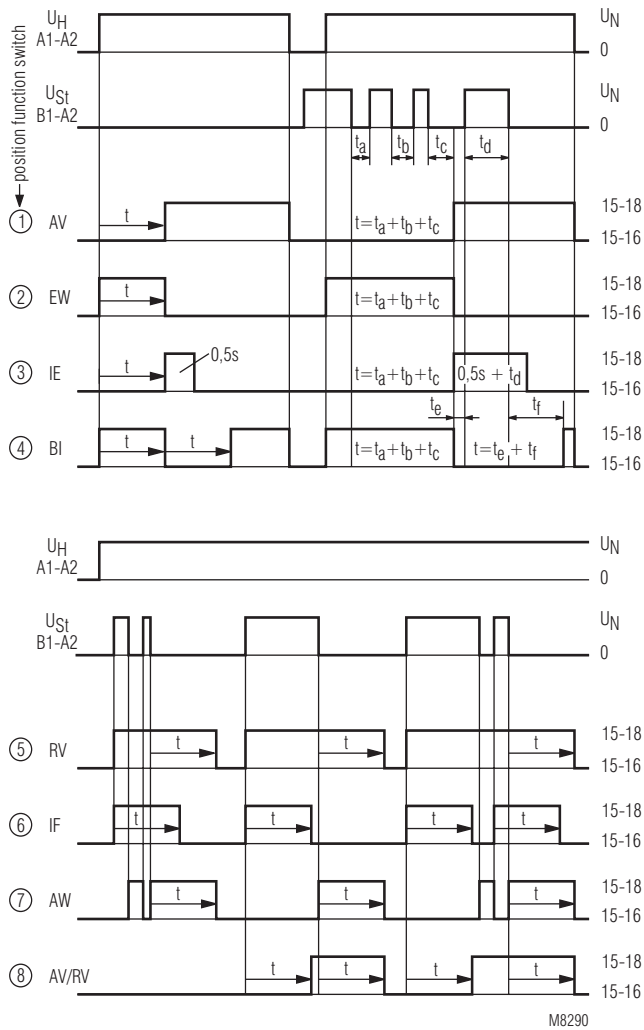

MK 7850N/200

① ... ⑧ = position of function switch

- | | |
|----------------------------------|---|
| ① AV = Delay on energisation | ⑤ RV = Delay on de-energisation |
| ② EW = Fleeting on make | ⑥ IF = Pulse forming function |
| ③ IE = Delayed pulse | ⑦ AW = Fleeting on break |
| ④ BI = Flasher, start with pulse | ⑧ AV/RV = Delay on energisation and de-energisation |

Function diagram

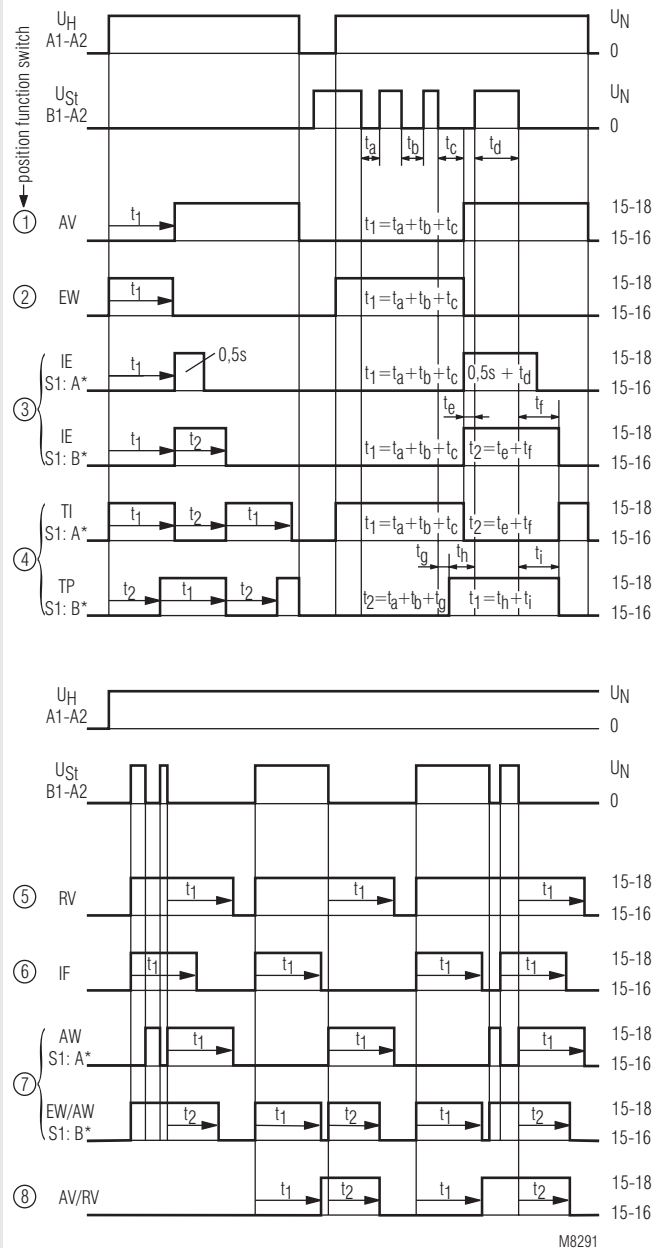

*) A and B indicate the position of function slide switch S1

MK 7850N/500

① ... ⑧ = position of function switch

- | | |
|---|---|
| ① AV = Delay on energisation | ⑤ RV = Delay on de-energisation |
| ② EW = Fleeting on make | ⑥ IF = Pulse forming function |
| ③ IE = Delayed pulse | ⑦ AW = Fleeting on break |
| S1 in position A:
t1: adjustable, t2=0,5s fixed | EW/AW = Fleeting on make and break |
| S1 in position B:
t1 and t2 adjustable | S1 in position B |
| ④ TI = Cyclic timer, start with pulse
S1 in position A | ⑧ AV/RV = Delay on energisation and de-energisation |
| TP = Cyclic timer, start with break
S1 in position B | |

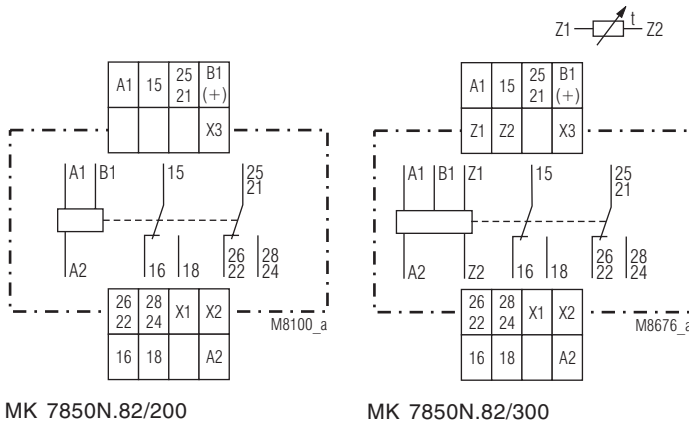

MK 7850N.82/200

MK 7850N.82/300

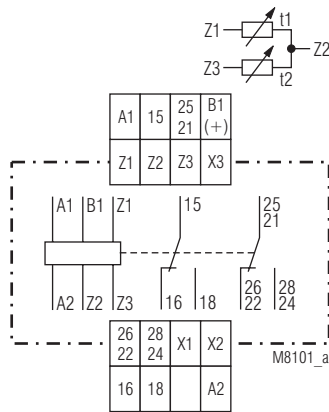

MK 7850N.82/500

Notes

Control of A1-A2 with proximity sensors

The input can be controlled by DC 3 wire or AC/DC 2 wire proximity sensors. For operating voltage > 24 V and usage of sensors without built-in short circuit protection a protection resistor on A1 is recommended to reduce the inrush current. The dimension is as follows:

$$R_v \approx \text{operating voltage} / \text{max. switching current of sensor}$$

The series resistor must not be selected higher than necessary.

Max. values are:

Operating voltage: 48 V 60 V 110 V 230 V

Series resistor R_v max: 270 Ω 390 Ω 680 Ω 1,8 k Ω (1 W)

Instantaneous contact

By external wire links the output function of the device can be altered from 2 delayed contacts to 1 delayed and 1 instantaneous contact. The instantaneous contact switches when the operating voltage is connected. To terminals X1 and X2 no other voltage potentials must be connected, as the unit might be damaged.

Adjustment assistance

The flashing period of the yellow LED is 1 s \pm 4 % and can be used to adjust the time. Especially on the lower end of scale and for long times it is suitable as the multiplication factors between the different time ranges are exact without tolerance.

Example:

The required time is 40 min. It has to be adjusted within range 3 ... 300 min. The time check takes too long as several timing cycles would be necessary for a precise value. For faster adjustment the setting is made to 0.03 ... 3 min. On this range the potentiometer should be set to 0.4 min (= 24 sec.). With the right potentiometer setting the LED must show 24 flashing cycles. After that the time range is switched over to 3 ... 300 min. and the setting is complete.

Time interruption / time adding with B1

With the functions AV, EW, IE and BI the time delay can be interrupted by controlling input B1 (+) with control voltage. Removing the control signal will continue the timing cycle (time addition).

Control input B1

The functions RV, IF, AW, AV / RV have to be controlled via input B1 (+) with voltage against A2. The control signal could be the same as the auxiliary/control voltage of A1 or any other voltage between 12 and 240 V AC or DC. Operating a parallel load between B1 and A2 is also possible.

If with function IF the inputs A1 and B1 are controlled simultaneously a pulse with the adjusted length is started. With the variant MK7850N/500 the output pulse can be disabled by setting the slide switch in Position "B".

Time interruption and time addition with X3

On all functions, also with RV, IF, AW (EW/AW) and AB/RV the time delay can be interrupted during timing by bridging the terminals X2 - X3. By opening the bridge the time continues (time addition). While X2 and X3 are bridged the control input is disabled and the yellow LED remains in the state it had at stop. No external voltage must be connected to X2 and X3 as the unit may be damaged.

Remote potentiometers

Both settings on variant MK 7850N/500 can also be made by remote potentiometers of 10 kOhms:

- terminals Z1 - Z2: potentiometer for time t1

- terminals Z2 - Z3: potentiometer for time t2

When connecting a remote potentiometer the corresponding potentiometer has to be set to min. If no remote potentiometers are required the terminals Z1-Z2 resp. Z2-Z3 have to be linked.

The wires to the remote potentiometers should be installed separately from the lines with mains voltage. If this is not possible, a screened cable is recommended where the shield is connected to Z2.

To terminals Z1, Z2 and Z3 no external voltage must be connected, as the unit might be damaged.

Additional function

With the variant MK7850N/500 additional features can be selected for the functions position 3, 4 and 7 using the slide switch S1 on the relay front in position "B". At the same time a second time setting t2 is available on the lower potentiometer (see function diagram) the time range is the same as for t1.

Setting

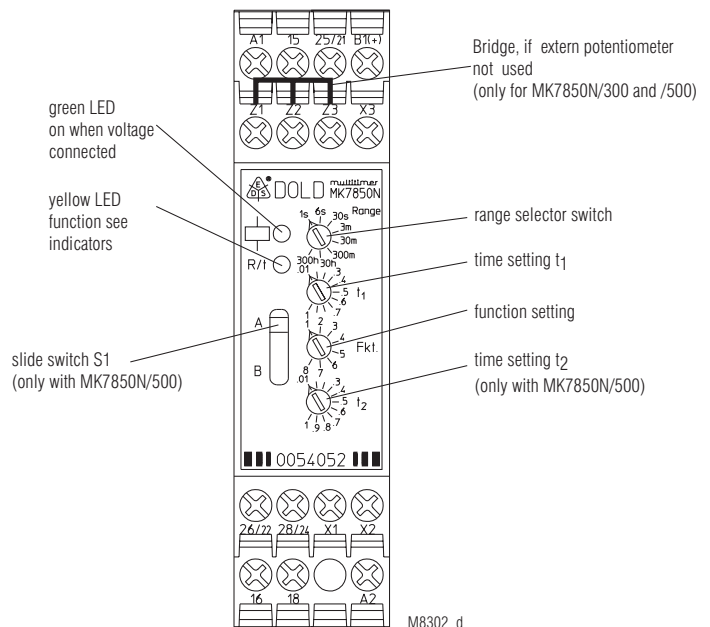

Attention

If no remote potentiometers at MK 7850N/500 are required the terminals Z1-Z2 resp. Z2-Z3 have to be linked.

Technical data

Time circuit

Time ranges:	8 time ranges in one unit, settable via rotational switch
	0.02 ... 1 s 0.3 ... 30 min
	0.06 ... 6 s 3 ... 300 min
	0.3 ... 30 s 0.3 ... 30 h
	0.03 ... 3 min 3 ... 300 h
Time setting t1, t2:	continuous, 1:100 on relative scale (t2 only at MK 7850N/500)

Recovery time:	
at DC 24 V:	approx. 15 ms
at DC 240 V:	approx. 50 ms
at AC 230 V:	approx. 80 ms
Repeat accuracy:	± 0.5 % of selected end of scale value + 20 ms

Voltage and temperature influence:	< 1 % with the complete operating range
---	---

Input

Nominal voltage U_N:	AC/DC 12 ... 240 V
Voltage range:	0.8 ... 1.1 U _N
Release voltage (A1/A2)	
AC 50 Hz:	Delayed contact approx. 7,5 V
DC:	approx. 7 V
	Instantaneous contact
AC 50 Hz:	approx. 3 V
DC:	approx. 3.3 V
Max. permitted residual current with 2-wire proximity sensor control (A1-A2)	
up to AC/DC 150 V:	AC resp. DC 5 mA
up to AC/DC 264 V:	AC resp. DC 3 mA
Control current B1:	approx. 1 mA, over complete voltage range
Min. on/off time of control input B1(+):	
AC 50 Hz:	approx. 15 ms / ca. 60 ms
DC:	approx. 5 ms / ca. 60 ms
Release voltage (B1/A2)	
AC 50 Hz:	approx. 3.5 V
DC:	approx. 3 V
Nominal power consumption	
AC 12 V:	approx. 1.5 VA
AC 24 V:	approx. 2 VA
AC 240 V:	approx. 3 VA
DC 12 V:	approx. 1 W
DC 24 V:	approx. 1 W
DC 240 V:	approx. 1 W
Nominal frequency:	45 ... 400 Hz

Output

Contacts	
MK 7850N.82:	2 changeover contacts, one programmable as instantaneous contact:
without bridge X1-X2:	25-26-28 delayed changeover contact
with bridge X1-X2:	21-22-24 instantaneous contact at U _N on A1-A2
	2 x 4 A
Thermal current I_{th}:	
Switching capacity	
to AC 15	
NO contact:	3 A / AC 230 V IEC/EN 60 947-5-1
NC contact:	1 A / AC 230 V IEC/EN 60 947-5-1
to DC 13:	1 A / DC 24 V IEC/EN 60 947-5-1
Electrical life	IEC/EN 60 947-5-1
to AC 15 at 1 A, AC 230 V:	1,5 x 10 ⁵ switching cycles
Short circuit strength	
max. fuse rating:	4 A gL IEC/EN 60 947-5-1
Mechanical life:	≥ 30 x 10 ⁶ switching cycles

General data

Operating mode:	Continuous operation
Temperature range:	- 40 ... + 60 °C

Technical data

Clearance and creepage distances

overvoltage category / pollution degree:	4 kV / 3 IEC 60 664-1 (4 kV / 2 at MK 7850N.82/61)
--	--

EMC

Electrostatic discharge:	8 kV (air) IEC/EN 61 000-4-2
HF-irradiation:	30 V / m IEC/EN 61 000-4-3
Fast transients:	2 kV IEC/EN 61 000-4-4
Surge voltages between wires for power supply:	2 kV IEC/EN 61 000-4-5
between wire and ground:	4 kV IEC/EN 61 000-4-5
HF-wire guided:	10 V IEC/EN 61 000-4-6
Interference suppression:	Limit value class B EN 55 011

Degree of protection

Housing:	IP 40 IEC/EN 60 529
Terminals:	IP 20 IEC/EN 60 529

Housing:

Thermoplastic with V0 behaviour according to UL subject 94
Amplitude 0,35 mm, frequency 10 ... 55 Hz, IEC/EN 60 068-2-6
40 / 060 / 04 IEC/EN 60 068-1
EN 50 005

Climate resistance:

Terminal designation:

Wire connection

Screw terminals

(integrated):

1 x 4 mm ² solid or
1 x 2.5 mm ² stranded ferruled or
2 x 1.5 mm ² stranded ferruled or
2 x 2.5 mm ² solid

Insulation of wires or sleeve length:	8 mm
---------------------------------------	------

Plugin with screw terminals

max. cross section for connection:	1 x 2.5 mm ² solid or 1 x 2.5 mm ² stranded ferruled
------------------------------------	--

Insulation of wires or sleeve length:	8 mm
---------------------------------------	------

Plugin with cage clamp terminals

max. cross section for connection:	1 x 4 mm ² solid or 1 x 2.5 mm ² stranded ferruled
------------------------------------	--

min. cross section for connection:	0.5 mm ²
------------------------------------	---------------------

Insulation of wires or sleeve length:	12 ±0.5 mm
---------------------------------------	------------

Wire fixing:

Plus-minus terminal screws M 3.5 box terminals with wire protection or cage clamp terminals

Box terminals with wire protection

DIN rail IEC/EN 60 715

Weight:	approx. 150 g
----------------	---------------

Dimensions

Width x height x depth

MK 7850N/200:	22.5 x 90 x 97 mm
MK 7850N/200 PC:	22.5 x 111 x 97 mm
MK 7850N/200 PS:	22.5 x 104 x 97 mm

Standardtype

MK 7850N.82/200 AC/DC 12 ... 240 V
 Article number: 0054050
 • Output: 2 changeover contacts, one programmable as instantaneous contact
 • Nominal voltage U_N : AC/DC 12 ... 240 V
 • Time ranges: from 0.02 s ... 300 h
 • Width: 22.5 mm

Variants

MK 7850N.82/61: With UL-approval (Canada/USA)
 MK 7850N.82/500: With 2 additional functions selectable via slide switch S1:
 - Cyclic timer, start with break (TP)
 - Fleeting on make and break (EW/AW)
 second time setting t2, connection facility for 2 remote potentiometers 10 k Ω to adjust t1 and t2
 MK7850.82/300: connection facility for 1 remote potentiometer 10 k Ω

Ordering example for variant

MK 7850N .82 PS / _ _ _ AC/DC 12 ... 240 V

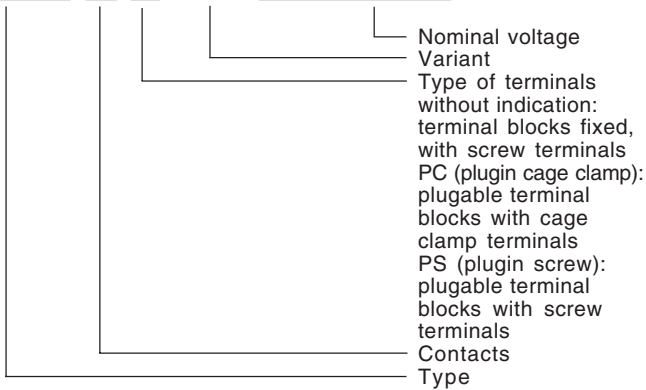

Accessories

AD 3: External potentiometer 10 k Ω
 The external potentiometer is used for remote setting of the time delay. The internal potentiometer of the timer must be set to min. time delay.

Degree of protection front side:

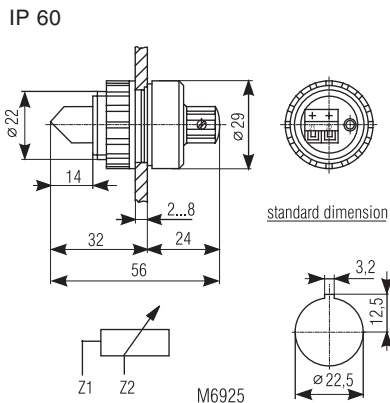

Connection examples

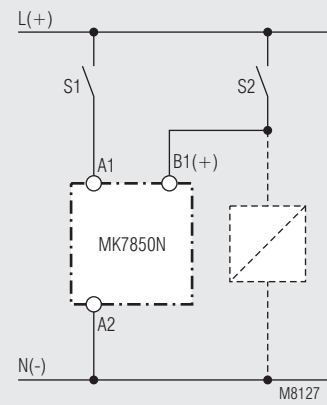
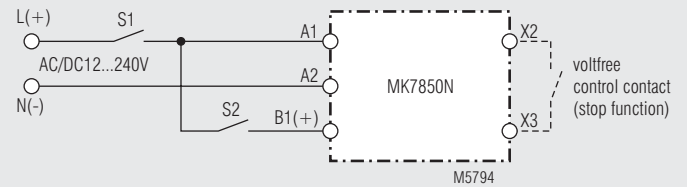

Control with parallel connected load

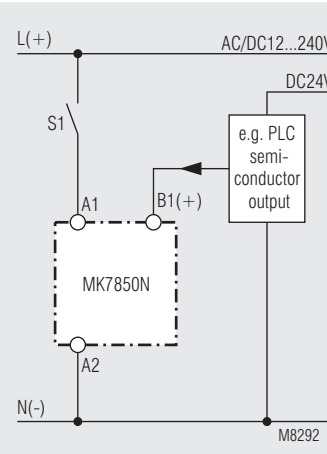

Connection with 2 different control voltages.

