

1.0 Features

- Primary-side feedback eliminates opto-isolators and simplifies design
- Quasi-resonant operation for highest overall efficiency
- **EZ-EMI**® design to easily meet global EMI standards
- Up to 130 kHz switching frequency enables small adapter size
- Very tight LED constant current regulation
- No external compensation components required
- Built-in output constant-current control with primary-side feedback for LED driver.
- Low start-up current (10 μ A typical)
- Built-in soft start
- Built-in short circuit protection and output overvoltage protection
- Current sense resistor short protection
- Overtemperature Protection
- Open circuit protection
- Universal input range from 85 V_{ac} to 264 V_{ac}
- Single-fault protection
- Small input bulk capacitor
- Long MTBF
- High efficiency

2.0 Description

The iW3620 is a high performance AC/DC offline LED driver which uses digital control technology to build peak current mode PWM flyback power supplies. The device operates in quasi-resonant mode at heavy load to provide high efficiency along with a number of key built-in protection features while minimizing the external component count, simplifying EMI design and lowering the total bill of material cost. The iW3620 removes the need for secondary feedback circuitry while achieving excellent line and load regulation. It also eliminates the need for loop compensation components while maintaining stability over all operating conditions. Pulse-by-pulse waveform analysis allows for a loop response that is much faster than traditional solutions, resulting in improved dynamic load response. The built-in current limit function enables optimized transformer design in universal off-line applications over a wide input voltage range.

3.0 Applications

- LED lighting

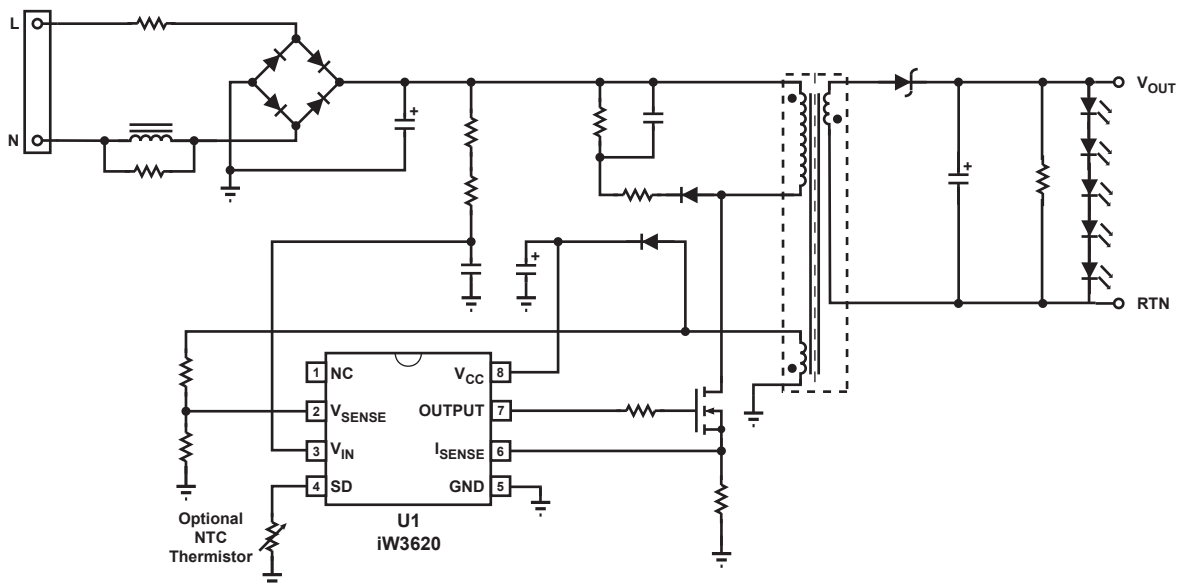
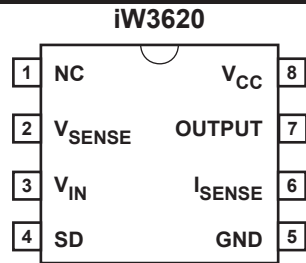

Figure 3.1 : Typical Application Circuit

4.0 Pinout Description



Pin #	Name	Type	Pin Description
1	NC	-	No connection.
2	V _{SENSE}	Analog Input	Auxiliary voltage sense (used for primary side regulation).
3	V _{IN}	Analog Input	Rectified AC line average voltage sense.
4	SD	Analog Input	External shutdown control. Connect to ground through a resistor if not used. (see Section 10.16)
5	GND	Ground	Ground.
6	I _{SENSE}	Analog Input	Primary current sense (used for cycle-by-cycle peak current control and limit).
7	OUTPUT	Output	Gate drive for external MOSFET switch.
8	V _{CC}	Power Input	Power supply for control logic and voltage sense for power-on reset circuitry.

5.0 Absolute Maximum Ratings

Absolute maximum ratings are the parameter values or ranges which can cause permanent damage if exceeded. For maximum safe operating conditions, refer to Electrical Characteristics in Section 6.0.

Parameter	Symbol	Value	Units
DC supply voltage range (pin 8, $I_{CC} = 20\text{mA max}$)	V_{CC}	-0.3 to 18	V
DC supply current at V_{CC} pin	I_{CC}	20	mA
Output (pin 7)		-0.3 to 18	V
V_{SENSE} input (pin 2, $I_{V_{sense}} \leq 10\text{ mA}$)		-0.7 to 4.0	V
V_{IN} input (pin 3)		-0.3 to 18	V
I_{SENSE} input (pin 6)		-0.3 to 4.0	V
SD input (pin 4)		-0.3 to 18	V
Power dissipation at $T_A \leq 25^\circ\text{C}$	P_D	526	mW
Maximum junction temperature	$T_{J\text{ MAX}}$	125	$^\circ\text{C}$
Storage temperature	T_{STG}	-65 to 150	$^\circ\text{C}$
Lead temperature during IR reflow for ≤ 15 seconds	T_{LEAD}	260	$^\circ\text{C}$
Thermal Resistance Junction-to-PCB Board Surface Temperature	ψ_{JB} (Note 1)	70	$^\circ\text{C/W}$
ESD rating per JEDEC JESD22-A114		2,000	V
Latch-Up test per JEDEC 78		± 100	mA

Notes:

Note 1. ψ_{JB} [Psi Junction to Board] provides an estimation of the die junction temperature relative to the PCB [Board] surface temperature. This data is measured at the ground pin (pin 5) without using any thermal adhesives. See Section 9.14 for more information.

6.0 Electrical Characteristics

$V_{CC} = 12\text{ V}$, $-40^\circ\text{C} \leq T_A \leq 85^\circ\text{C}$, unless otherwise specified (Note 1)

Parameter	Symbol	Test Conditions	Min	Typ	Max	Unit
V_{IN} SECTION (Pin 3)						
Start-up low voltage threshold ($V_{IN(A)}$) at internal ADC input (see Figure 8.1) (Note 2)	$V_{IN(A)(STLOW)}$	$T_A = 25^\circ\text{C}$, positive edge	335	369	406	mV
Start-up low voltage threshold (V_{IN})	$V_{IN(STLOW)}$		363	413	477	mV
Start-up current	I_{INST}	$V_{IN} = 10\text{ V}$, $C_{VCC} = 10\ \mu\text{F}$		10	15	μA
Input impedance	Z_{IN}	After start-up		5		k Ω
V_{SENSE} SECTION (Pin 2)						
Input leakage current	I_{BVS}	$V_{SENSE} = 2\text{ V}$			1	μA
Nominal voltage threshold	$V_{SENSE(NOM)}$	$T_A = 25^\circ\text{C}$, negative edge	1.523	1.538	1.553	V
Output OVP threshold (Note 2)	$V_{SENSE(MAX)}$	$T_A = 25^\circ\text{C}$, negative edge	1.790	1.846	1.900	V
OUTPUT SECTION (Pin 7)						
Output low level ON-resistance	$R_{DS(ON)LO}$	$I_{SINK} = 5\text{ mA}$		40		Ω
Output high level ON-resistance	$R_{DS(ON)HP}$	$I_{SOURCE} = 5\text{ mA}$		75		Ω
Rise time (Note 2)	t_R	$T_A = 25^\circ\text{C}$, $C_L = 330\text{ pF}$ 10% to 90%		200	300	ns
Fall time (Note 2)	t_F	$T_A = 25^\circ\text{C}$, $C_L = 330\text{ pF}$ 90% to 10%		40	60	ns
Maximum switching frequency	$f_{SW(MAX)}$	Any combination of line and load		130	140	kHz
V_{CC} SECTION (Pin 8)						
Maximum operating voltage (Note 2)	$V_{CC(MAX)}$				16	V
Start-up threshold	$V_{CC(ST)}$	V_{CC} rising	10.8	12	13.2	V
Undervoltage lockout threshold	$V_{CC(UVL)}$	V_{CC} falling	5.5	6.0	6.6	V
Operating current	I_{CCQ}	$C_L = 330\text{ pF}$, $V_{SENSE} = 1.5\text{ V}$		3.5	5	mA

6.0 Electrical Characteristics (cont.)

$V_{CC} = 12\text{ V}$, $-40^{\circ}\text{C} \leq T_A \leq 85^{\circ}\text{C}$, unless otherwise specified (Note 1)

Parameter	Symbol	Test Conditions	Min	Typ	Max	Unit
I_{SENSE} SECTION (Pin 6)						
Peak limit threshold	V_{PEAK}		1.045	1.1	1.155	V
Isense short protection reference	V_{RSNS}		0.127	0.15	0.173	V
CC regulation threshold limit (Note 2)	V_{REG-TH}			1.0		V
SD SECTION (Pin 4)						
Shutdown threshold	V_{SD-TH}	$T_A = 25^{\circ}\text{C}$	0.95	1.0	1.05	V
Shutdown threshold in Startup (Note 2)	$V_{SD-TH(ST)}$			1.2		V
Input leakage current	I_{BVSD}	$V_{SD} = 1.0\text{ V}$			1	μA
Pull down resistance	R_{SD}	$T_A = 25^{\circ}\text{C}$	7916	8333	8750	Ω
Pull up current source	I_{SD}	$T_A = 25^{\circ}\text{C}$	96	107	118	μA

Notes:

Note 1. Adjust V_{CC} above the start-up threshold before setting at 12 V.

Note 2. These parameters are not 100% tested, guaranteed by design and characterization.

Note 3. Operating frequency varies based on the line and load conditions, see Theory of Operation for more details.

7.0 Typical Performance Characteristics

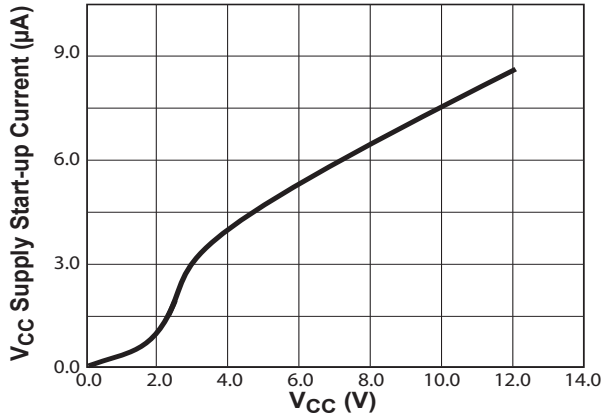

Figure 7.1 : V_{CC} Supply Current vs. V_{CC}

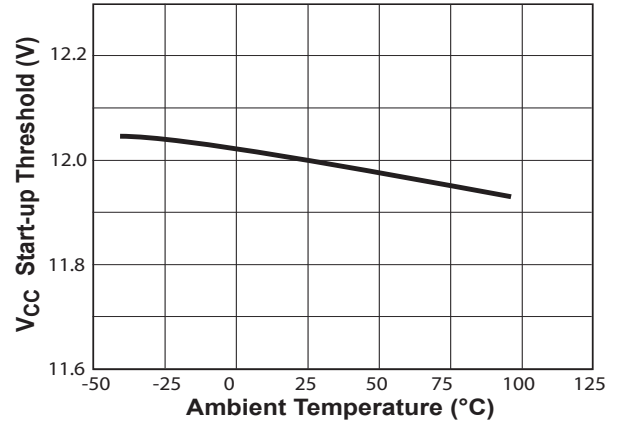

Figure 7.2 : Start-Up Threshold vs. Temperature

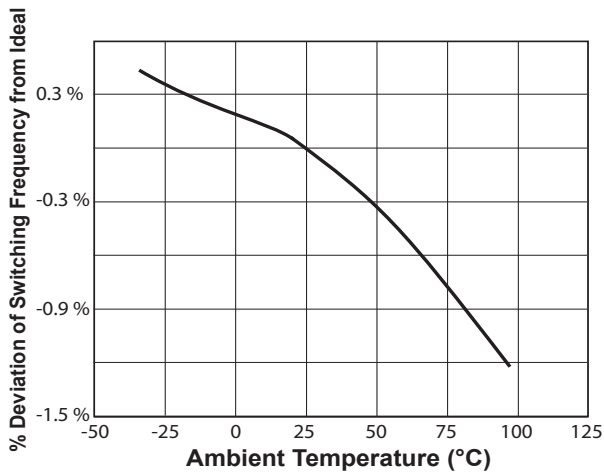

Figure 7.3 : Switching Frequency % Change vs. Temperature

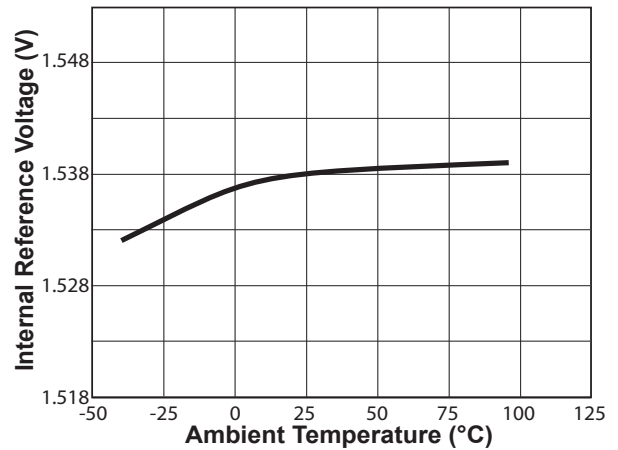

Figure 7.4 : Internal Reference vs. Temperature

8.0 Functional Block Diagram

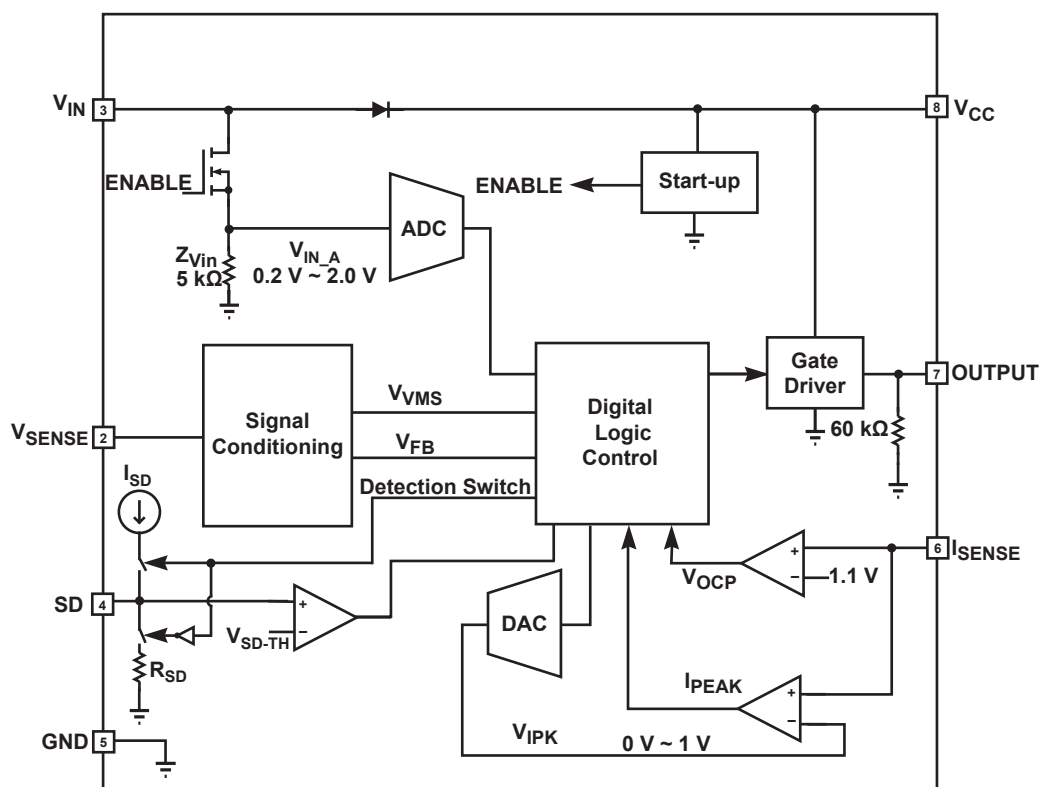

Figure 8.1 : iW3620 Functional Block Diagram

9.0 Theory of Operation

The iW3620 is a digital controller which uses a proprietary primary-side control technology to eliminate the opto-isolated feedback and secondary regulation circuits required in traditional designs. This results in a low-cost solution for AC/DC adapters. The iW3620 uses Critical Discontinuous Conduction Mode (CDCM) or Pulse Width Modulation (PWM) mode at high output power levels and switches to Pulse Frequency Modulation (PFM) mode at light load to minimize power dissipation to meet EPA 2.0 specification. Furthermore, iWatt's digital control technology enables fast dynamic response, tight output regulation, and full featured circuit protection with primary-side control.

Referring to the block diagram in Figure 8.1, the digital logic control block generates the switching on-time and off-time information based on the line voltage and the output voltage feedback signal and provides commands to dynamically control the external MOSFET current. The system loop is compensated internally by a digital error amplifier. Adequate system phase and gain margin are guaranteed by design and no external analog components are required for loop compensation. The iW3620 uses an advanced digital

control algorithm to reduce system design time and improve reliability.

Furthermore, accurate secondary constant-current operation is achieved without the need for any secondary-side sense and control circuits.

The built-in protection features include overvoltage protection (OVP), output short circuit protection (SCP) and soft-start, AC line brown out, overcurrent protection, and Isense fault protection. Also the iW3620 automatically shuts down if it detects any of its sense pins to be either open or short.

iWatt's digital control scheme is specifically designed to address the challenges and trade-offs of power conversion design. This innovative technology is ideal for balancing new regulatory requirements for green mode operation with more practical design considerations such as lowest possible cost, smallest size and highest performance output control.

9.1 Pin Detail

Pin 2 – V_{SENSE}

Sense signal input from auxiliary winding. This provides the secondary voltage feedback used for output regulation.

Pin 3 – V_{IN}

Sense signal input from the rectified line voltage. V_{IN} is used for line regulation. The input line voltage is scaled down using a resistor network. It is used for input undervoltage and overvoltage protection. This pin also provides the supply current to the IC during start-up.

Pin 4 – SD

External shutdown control. If the shutdown control is not used, this pin should be connected to GND via a resistor.

Pin 5 – GND

Ground.

Pin 6 – I_{SENSE}

Primary current sense. Used for cycle by cycle peak current control.

Pin 7 – OUTPUT

Gate drive for the external MOSFET switch.

Pin 8 – V_{CC}

Power supply for the controller during normal operation. The controller will start up when V_{CC} reaches 12 V (typical) and will shut-down when the V_{CC} voltage is below 6 V (typical). A decoupling capacitor should be connected between the V_{CC} pin and GND.

9.2 Start-up

Prior to start-up the V_{IN} pin charges up the V_{CC} capacitor through the diode between V_{IN} and V_{CC} (see Figure 8.1).

When V_{CC} is fully charged to a voltage higher than the start-up threshold $V_{CC(ST)}$, the ENABLE signal becomes active and enables the control logic; the V_{IN} switch turns on, and the analog-to-digital converter begins to sense the input voltage. Once the voltage on the V_{IN} pin is above $V_{INSTLOW}$, the iW3620 commences soft start function. An adaptive soft-start control algorithm is applied at startup state, during which the initial output pulses will be small and gradually get larger until the full pulse width is achieved. The peak current is limited cycle by cycle by I_{PEAK} comparator.

If at any time the V_{CC} voltage drops below $V_{CC(UVL)}$ threshold then all the digital logic is reset. At this time V_{IN} switch

turns off so that the V_{CC} capacitor can be charged up again towards the start-up threshold. Figure 9.1 shows the start-up sequence of the iW3620.

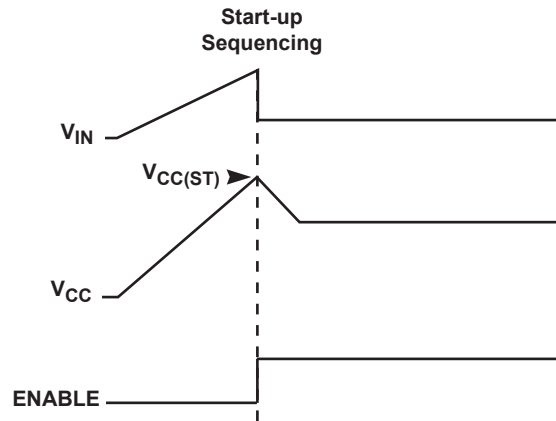

Figure 9.1 : Start-up Sequencing Diagram

9.3 Understanding Primary Feedback

Figure 9.2 illustrates a simplified flyback converter. When the switch Q_1 conducts during $t_{ON}(t)$, the current $i_g(t)$ is directly drawn from rectified sinusoid $v_g(t)$. The energy $E_g(t)$ is stored in the magnetizing inductance L_M . The rectifying diode D_1 is reverse biased and the load current I_O is supplied by the secondary capacitor C_O . When Q_1 turns off, D_1 conducts and the stored energy $E_g(t)$ is delivered to the output.

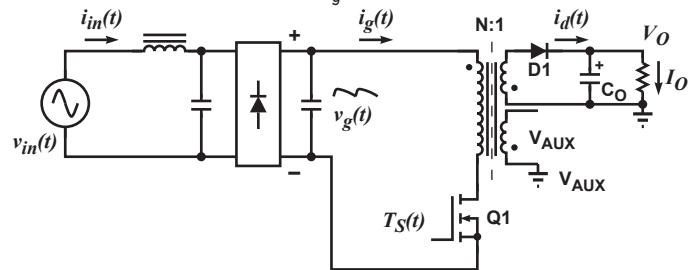

Figure 9.2 : Simplified Flyback Converter

In order to tightly regulate the output voltage, the information about the output voltage and load current needs to be accurately sensed. In the DCM flyback converter, this information can be read via the auxiliary winding. During the Q_1 on-time, the load current is supplied from the output filter capacitor C_O . The voltage across L_M is $v_g(t)$, assuming the voltage dropped across Q_1 is zero. The current in Q_1 ramps up linearly at a rate of:

$$\frac{di_g(t)}{dt} = \frac{v_g(t)}{L_M} \quad (9.1)$$

At the end of on-time, the current has ramped up to:

$$i_{g_peak}(t_{ON}) = \frac{v_g(t) \times t_{ON}}{L_M} \quad (9.2)$$

This current represents a stored energy of:

$$E_g = \frac{L_M}{2} \times i_{g_peak}(t_{ON})^2 \quad (9.3)$$

When Q_1 turns off, $i_g(t)$ in L_M forces a reversal of polarities on all windings. Ignoring the communication-time caused by the leakage inductance L_K at the instant of turn-off, the primary current transfers to the secondary at a peak amplitude of:

$$i_d(t) = \frac{N_P}{N_S} \times i_{g_peak}(t_{ON}) \quad (9.4)$$

Assuming the secondary winding is master and the auxiliary winding is slave.

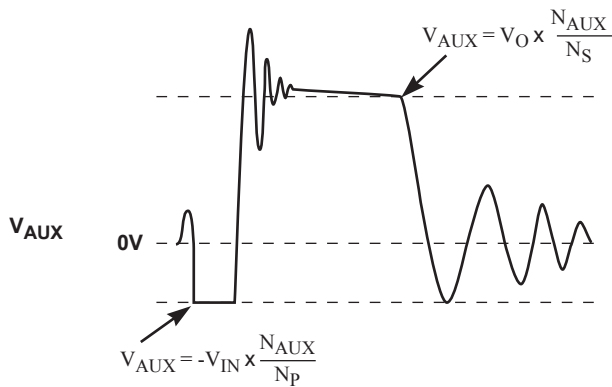

Figure 9.3 : Auxiliary Voltage Waveforms

The auxiliary voltage is given by:

$$V_{AUX} = \frac{N_{AUX}}{N_S} (V_O + \Delta V) \quad (9.5)$$

and reflects the output voltage as shown in Figure 9.3.

The voltage at the load differs from the secondary voltage by a diode drop and IR losses. The diode drop is a function of current, as are IR losses. Thus, if the secondary voltage is always read at a constant secondary current, the difference between the output voltage and the secondary voltage will be a fixed ΔV . Furthermore, if the voltage can be read when the secondary current is small; for example, at the knee of the auxiliary waveform (see Figure 9.3), then ΔV will also be small. With the iW3620, ΔV can be ignored.

The real-time waveform analyzer in the iW3620 reads the auxiliary waveform information cycle by cycle. The part then generates a feedback voltage V_{FB} . The V_{FB} signal precisely

represents the output voltage and is used to regulate the output voltage.

9.4 Dynamic Load Transient

There are two components that compose the voltage drop during a load transient event.

$V_{DROP(sense)}$ is the drop in voltage before the V_{SENSE} signal is able to show a significant drop in output voltage. This is determined by V_{min} or the reference voltage at which a load transient is detected. The smaller the V_{min} means the smaller this drop in voltage is.

$$V_{DROP(sense)} = (V_{SENSE(nom)} - V_{SENSE(min)}) \times \frac{V_{OUT}}{V_{SENSE(nom)}} \quad (9.7)$$

Keep in mind that a smaller V_{min} is less tolerant of noise and distortions in V_{SENSE} than a larger one.

The final drop in voltage is due to the time from when V_{SENSE} drops V_{min} to when the next V_{SENSE} signal appears. In the worst case condition this is how much voltage drops during the longest switching period.

$$V_{DROP(IC)} = \frac{I_{OUT} \times T_{P(No\ load)}}{C_{OUT}} \quad (9.8)$$

A larger output capacitance in this case greatly reduces the $V_{DROP(IC)}$.

9.5 Valley Mode Switching

In order to reduce switching losses in the MOSFET and EMI, the iW3620 employs valley mode switching when I_{OUT} is above 50%. In valley mode switching, the MOSFET switch is turned on at the point where the resonant voltage across the drain and source of the MOSFET is at its lowest point (see Figure 9.4). By switching at the lowest V_{DS} , the switching loss will be minimized.

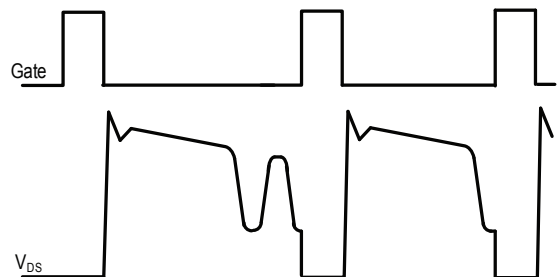

Figure 9.4 : Valley Mode Switching

Turning on at the lowest V_{DS} generates lowest dV/dt , thus valley mode switching can also reduce EMI. To limit the switching frequency range, the iW3620 can skip valleys

(seen in the first cycle in Figure 9.4) when the switching frequency becomes too high.

iW3620 provides valley mode switching during constant current (CC) output operation. So, the EMI and switching losses are still minimized during CC mode. This feature is superior to other quasi-resonant technologies which only support valley mode switching during constant voltage operation. This is beneficial to LED driver applications where the IC mainly operates in CC mode.

9.6 Constant Voltage Operation

After soft-start has been completed, the digital control block measures the output conditions. It determines output power levels and adjusts the control system according to a light load or a heavy load. If this is in the normal range, the device operates in the Constant Voltage (CV) mode, and changes the pulse width (T_{ON}), and off time (T_{OFF}) in order to meet the output voltage regulation requirements. During this mode the PWM switching frequency is between 30 kHz and 130 kHz, depending on the line and load conditions.

If less than 0.2 V is detected on V_{SENSE} it is assumed that the auxiliary winding of the transformer is either open or shorted and the iW3620 shuts down.

9.7 Constant Current Operation

The constant current mode (CC mode) maintains a constant current output. During this mode of operation the iW3620 will regulate the output current at a constant level regardless of the output voltage, while avoiding continuous conduction mode. Figure 9.5 shows the operation modes of the iW3620.

To achieve this regulation the iW3620 senses the load current indirectly through the primary current. The primary current is detected by the I_{SENSE} pin through a resistor from the MOSFET source to ground.

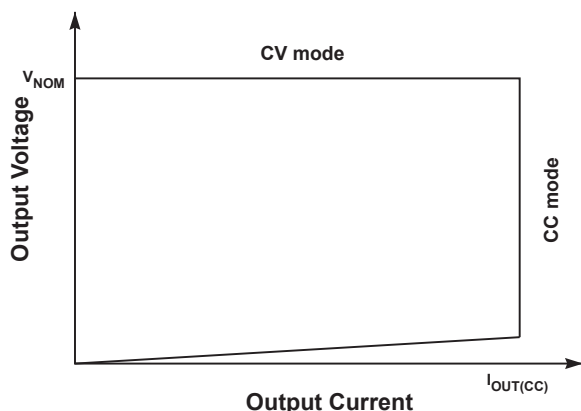

Figure 9.5 : Power Envelope

9.8 PFM Mode at Light Load

The iW3620 normally operates in a fixed frequency PWM or critical discontinuous conduction mode when I_{OUT} is greater than approximately 10% of the specified maximum load current. As the output load I_{OUT} is reduced, the on-time t_{ON} is decreased. At the moment that the load current drops below 10% of nominal, the controller transitions to Pulse Frequency Modulation (PFM) mode. Thereafter, the on-time will be modulated by the line voltage and the off-time is modulated by the load current. The device automatically returns to PWM mode when the load current increases.

9.9 Variable Frequency Operation

At each of the switching cycles, the falling edge of V_{SENSE} will be checked. If the falling edge of V_{SENSE} is not detected, the off-time will be extended until the falling edge of V_{SENSE} is detected. The maximum allowed transformer reset time is 75 μ s for iW3620.

9.10 Internal Loop Compensation

The iW3620 incorporates an internal Digital Error Amplifier with no requirement for external loop compensation. For a typical power supply design, the loop stability is guaranteed to provide at least 45 degrees of phase margin and -20dB of gain margin.

9.11 Voltage Protection Functions

The iW3620 includes a function that protects against an output overvoltage (OVP).

The output voltage is monitored by the V_{SENSE} pin. If the voltage at this pin exceed its overvoltage threshold the iW3620 shuts down immediately. However, the IC remains biased which discharges the V_{CC} supply. Once V_{CC} drops below the UVLO threshold, the controller resets itself and then initiates a new soft-start cycle. The controller continues attempting start-up until the fault condition is removed.

9.12 PCL, OC and SRS Protection

Peak-current limit (PCL), over-current protection (OCP) and sense-resistor short protection (SRSP) are features built-into the iW3620. With the I_{SENSE} pin the iW3620 is able to monitor the primary peak current. This allows for cycle by cycle peak current control and limit. When the primary peak current multiplied by the I_{SENSE} sense resistor is greater than 1.1 V over current is detected and the IC will immediately turn off the gate drive until the next cycle. The output driver will send out switching pulse in the next cycle, and the switching pulse will continue if the OCP threshold is not reached; or, the switching pulse will turn off again if the OCP threshold is still reached.

If the I_{SENSE} sense resistor is shorted there is a potential danger of the over current condition not being detected. Thus the IC is designed to detect this sense-resistor-short fault after start-up, and shutdown immediately. The V_{CC} will be discharged since the IC remains biased. Once V_{CC} drops below the UVLO threshold, the controller resets itself and then initiates a new soft-start cycle. The controller continues attempting start-up, but does not fully start-up until the fault condition is removed.

9.13 Shutdown

The shutdown (SD) pin in the iW3620 provides protection against overtemperature (OTP) and additional overvoltage (OVP) for the power supply.

The iW3620 switches between monitoring overtemperature fault and overvoltage fault. In order to detect the resistance in the NTC for an overtemperature fault, the iW3620 connects a current source to the SD pin and checks the voltage on the pin. To ensure that the current source is settled before the voltage is checked both OTP and OVP are detected on the last cycle, as depicted in Figure 9.6.

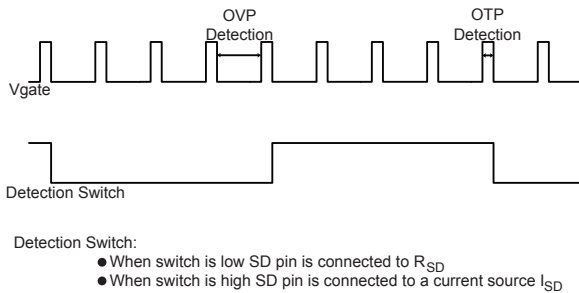

Figure 9.6 : SD Pin Detection Cycles

During an overvoltage monitor cycle the SD pin is connected to a resistance internal to the chip, R_{SD} , to ground and the voltage on the SD pin is observed. Figure 9.7 shows how the SD pin is configured inside the chip.

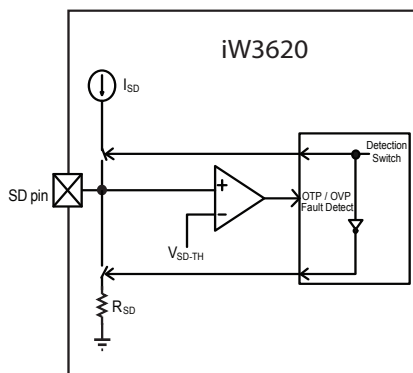

Figure 9.7 : Internal Function of SD Pin

9.14 Thermal Design

The iW3620 is typically installed inside a small enclosure, where space and air volumes are constrained. Under these circumstances θ_{JA} (thermal resistance, junction to ambient) measurements do not provide useful information for this type of application. Instead we have provided ψ_{JB} which estimates the increase in die junction temperature relative to the PCB surface temperature. Figure 9.8 shows the PCB surface temperature is measured at the IC's GND pin pad.

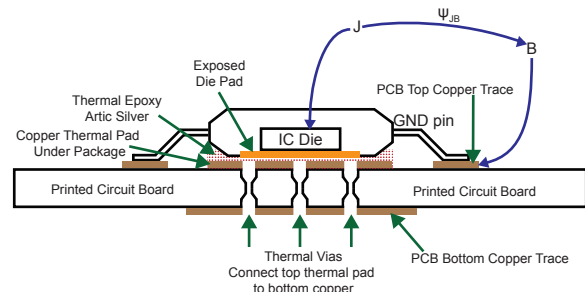

Figure 9.8 : Ways to Improve Thermal Resistance

Using ψ_{JB} , the junction temperature (T_J) of the IC can be found using the equation below.

$$T_J = T_B + P_H \cdot \psi_{JB} \quad (9.9)$$

where, T_B is the PCB surface temperature and P_H is the power applied to the chip or the product of V_{CC} and I_{CCQ} .

The iW3620 uses an exposed pad package to reduce the thermal resistance of the package. Although just by using an exposed package can provide some thermal resistance improvement, more significant improvements can be obtained with simple PCB layout and design. Figure 9.8 demonstrates some recommended techniques to improve thermal resistance, which are also highlighted below.

Ways to Improve Thermal Resistance

- Increase PCB area and associated amount of copper interconnect.
- Use thermal adhesive to attach the package to a thermal pad on PCB.
- Connect PCB thermal pad to additional copper on PCB.

Environment	ψ_{JB}
No Attachment to PCB	70 °C/W
Attach Package to PCB with Thermal Adhesive	63 °C/W
Use Thermal Adhesive and Thermal Vias	49 °C/W

Table 9.1 : Improvements in ψ_{JB} Based on Limited Experimentation

Effect of Thermal Resistance Improvements

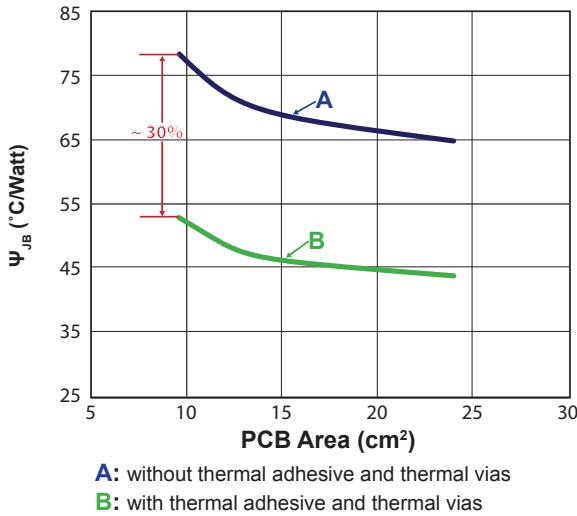

Figure 9.9 : Effect of Thermal Resistance Improvements

Figure 9.9 shows improvement of approximately 30% in thermal resistance across different PCB sizes when the exposed pad is attached to PCB using a thermal adhesive and thermal vias connect the pad to a larger plate on the opposing side of the PCB.

10.0 Design Example

10.1 Design Procedure

This design example gives the procedure for a flyback converter using iW3620. Refer to Figure 12.1 for the application circuit. The design objectives for this adapter are given in Table 10.1. It meets UL, IEC, and CEC requirements.

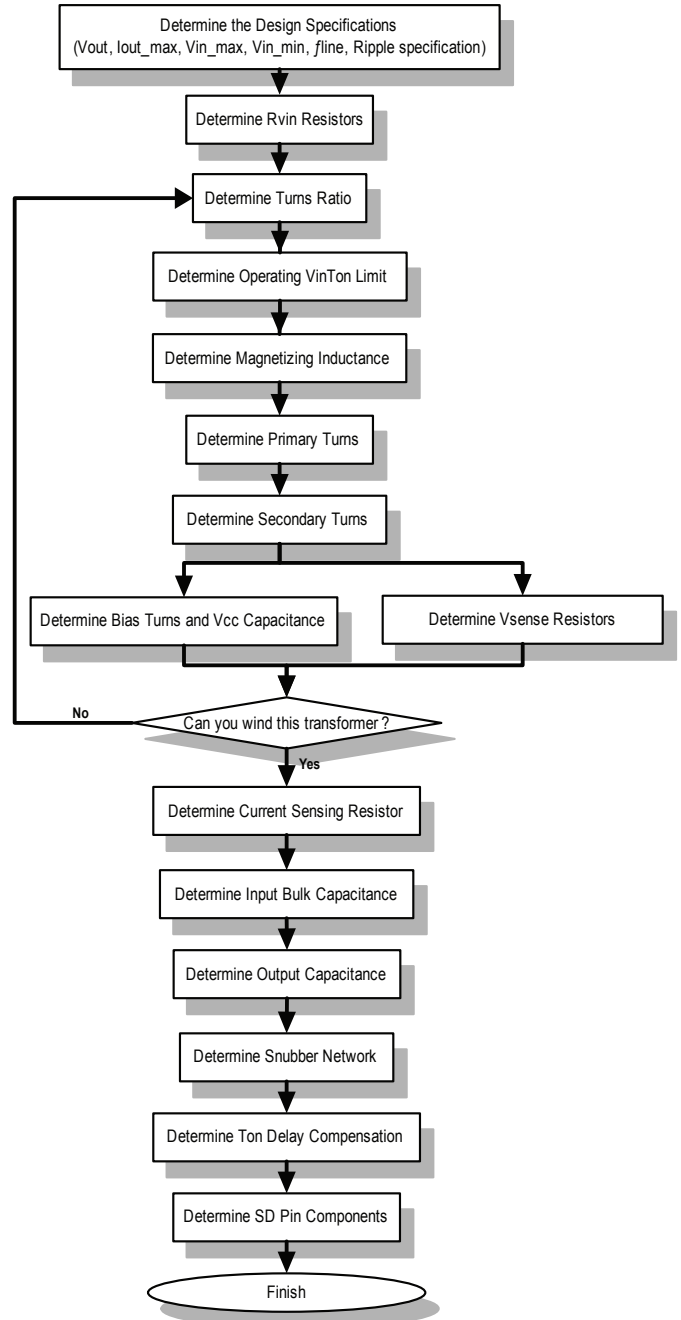

Figure 10.1 : Design Procedure

10.2 Determine Design Specifications

Parameter	Symbol	Range
Input Voltage	V_{IN}	90 - 264 V _{RMS}
Frequency	f_{IN}	47 - 64 Hz
Maximum Output Voltage	$V_{OUT(max)}$	24.0 V
Nominal Output Voltage	$V_{OUT(nom)}$	21.0 V
Maximum Output Current	$I_{OUT(max)}$	0.87 A
Nominal Output Current	$I_{OUT(nom)}$	0.5 A
Output Ripple	V_{RIPPLE}	< 100 mV
Power Out	P_{OUT}	20 W
EPA 2.0 Efficiency	η	84%

Table 10.1 : iW3620 Design Specification Table

Use equation 10.1 and 10.2 to determine V_{OUT} in the following calculations, where V_{FD} is the forward voltage of the output diode.

$$V_{OUT(PCB)} = 110\% \times V_{OUT(nom)} \quad (10.1)$$

$$V_{OUT} = V_{OUT(PCB)} + V_{FD} \quad (10.2)$$

For this example the nominal $V_{OUT(nom)}$ is 21 V, assuming V_{FD} is 0.5, V_{OUT} is:

$$V_{OUT(PCB)} = 110\% \times 21V = 23.1$$

$$V_{OUT} = 23.1V + 0.5V = 23.6V$$

10.3 Input Selection

V_{IN} resistors are chosen primarily to scale down the input voltage for the IC. The default scale factor for the input voltage in the IC is 0.0043 and the internal impedance of this pin is Z_{IN} (5 k Ω). Therefore, the V_{IN} resistors should equate to:

$$R_{Vin} = \frac{Z_{IN}}{0.0043} - Z_{IN} \quad (10.3)$$

From equation 10.3, ideally R_{Vin} should be 1.16 M Ω . A lower value of R_{Vin} can decrease the startup time of the power supply. The value of R_{Vin} affects the $(V_{IN} \cdot T_{ON})$ limits of the IC.

$$(V_{IN} \cdot T_{ON})_{limit} = 0.0043 \times \frac{720V \cdot \mu s}{Z_{IN} / (R_{Vin} + Z_{IN})} \quad (10.4)$$

$$(V_{IN} \cdot T_{ON})_{limit} = 0.0043 \times \frac{135V \cdot \mu s}{Z_{IN} / (R_{Vin} + Z_{IN})} \quad (10.5)$$

For this example R_{Vin} is chosen to be 1.12 M Ω therefore,

$$(V_{IN} \cdot T_{ON})_{limit} = 0.0043 \times \frac{720V \cdot \mu s}{5k\Omega / (1.12M\Omega + 5k\Omega)} = 697V \cdot \mu s$$

$$(V_{IN} \cdot T_{ON})_{limit} = 0.0043 \times \frac{135V \cdot \mu s}{5k\Omega / (1.12 + 5k\Omega)} = 131V \cdot \mu s$$

Keep in mind, by changing R_{Vin} to be something other than 1.16 M Ω the minimum and maximum input voltage for start-up also changes.

Since the iW3620 uses the exact scaled value of V_{IN} for its calculations, there should be a filter capacitor on the input pin to filter out any noise that may appear on the V_{IN} signal. This is especially important for line in surge conditions.

10.4 Turns Ratio

The maximum allowable turns ratio between the primary and secondary winding is determined by the minimum detectable reset time of the transformer during PFM mode.

$$N_{TR(max)} = \frac{(V_{IN} \cdot T_{ON})_{PFM}}{T_{RESET(min)} \times V_{OUT}} \quad (10.6)$$

Setting $T_{RESET(min)}$ at 1.5 μs ,

$$N_{TR(max)} = \frac{131V \cdot \mu s}{1.5\mu s \times 23.6V} = 3.70$$

For this example a turns ratio of 2.5 is chosen.

Keep in mind in valley mode switching the higher the turns ratio the lower the V_{DS} turn-on voltage, which means less switch turn-on power loss. Also consider the voltage stress on the MOSFET (V_{DS}) is higher with an increase in turns ratio. The voltage stress on the output diode is lower with an increase in turns ratio respectively.

10.5 Operating Maximum ($V_{IN} T_{ON}$)

Maximum operating $V_{IN} T_{ON}$ or $(V_{IN} T_{ON})_{MAX}$ for valley mode switching is traditionally designed at full load and lowest input voltage. For the iW3620, two constraints (equation 10.7 and 10.8) need to be satisfied so that indeed $(V_{IN} T_{ON})_{MAX}$ occurs at full load and lowest input voltage.

$$T_{P(QRmin)} > \frac{1}{100kHz} \quad (10.7)$$

$$T'_{P(QRmin)} > \frac{1}{110kHz} + T_{RES} \quad (10.8)$$

T_{RES} is the V_{DS} resonant period as shown in Figure 10.2. T_{RES} can be estimated to be approximately 2 μs as a starting point and then adjusted after the power supply is tested.

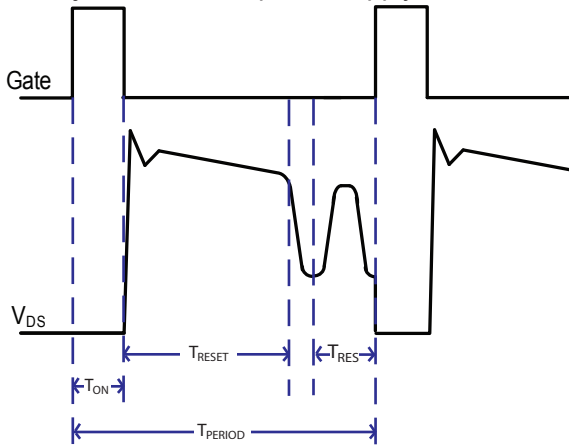

Figure 10.2 : V_{DS} Timing

When both criterion are met then $(V_{IN} \cdot T_{ON})_{MAX}$ can be determined by equation 10.9.

$$(V_{IN} \cdot T_{ON})_{max} = \left[f_{SW(max\ op)} \times \left(\frac{1}{V_{INDC(min)}} + \frac{1}{N_{TR} \times V_{OUT}} \right) \right]^{-1}$$

where, $f_{SW(max\ op)} = \frac{1}{T_{P(QRmin)}}$ (10.9)

Where $V_{INDC(min)}$ is the minimum input voltage across the bulk capacitor.

Assuming T_{RES} is 2 μs then:

$$T_{P(QRmin)} > 10\mu s$$

$$T'_{P(QRmin)} > \frac{1}{110kHz} + 2\mu s = 11.1\mu s$$

Using 80 V for $V_{INDC(min)}$,

$$f_{SW(max\ op)} = 85kHz, \text{ and } T_p = 11.76\mu s$$

$$(V_{IN} \cdot T_{ON})_{max} = \left[85kHz \times \left(\frac{1}{80V} + \frac{1}{2.5 \times 23.6} \right) \right]^{-1} = 399V \cdot \mu s$$

Also, to provide enough margin for component values, usually:

$$(V_{IN} \cdot T_{ON})_{max} < (V_{IN} \cdot T_{ON})_{limit} \times 0.85 \quad (10.10)$$

$$(V_{IN} \cdot T_{ON})_{max} < 697V \cdot \mu s \times 0.85 = 592V \cdot \mu s$$

Since we calculated 399 $V \cdot \mu s$ as our $V_{IN} \cdot T_{ON}$ we have enough margin.

10.6 Magnetizing Inductance

A feature of the iW3620 is the lack of dependence on the magnetizing inductance for the CC curve.

Although the constant current limit does not depend on the magnetizing inductance, there are still restrictions on the magnetizing inductance. The maximum L_M is limited by the amount of power that needs to come out of the transformer in order for the power supply to regulate. This is given by:

$$L_{M(max)} = \frac{(V_{IN} \cdot T_{ON})_{max}^2 \times f_{sw(max\ op)}}{2 \times P_{XFMR(max)}} \quad (10.11)$$

$$P_{XFMR(max)} = \frac{V_{OUT} \times I_{OUT}}{\eta_X}$$

Where η_X is the efficiency of the transformer, for this example we assume it's 87 %.

$$P_{XFMR(max)} = \frac{23.6V \times 0.5A}{0.87} = 13.6W$$

$$L_{M(max)} = \frac{(399V \cdot \mu s)^2 \times 85kHz}{2 \times 13.6W} = 0.497mH$$

The minimum L_M is limited by the maximum allowable peak primary current. V_{REG-TH} corresponds to the maximum I_{SENSE} voltage (see Section 10.11 to calculate R_{Isense}). Therefore L_M is limited by:

$$L_{M(min)} = \frac{2 \times P_{XFMR(max)}}{f_{SW(max\ op)} \times \left(\frac{V_{REG-TH}}{R_{Isense}} \right)^2} \quad (10.12)$$

$$L_{M(min)} = \frac{2 \times 13.6W}{85kHz \times \left(\frac{1.0V}{1.1\Omega} \right)^2} = 0.387mH$$

For this example, we choose L_M to be 0.438 mH.

If these limits do not give enough tolerance for L_M , increasing $(V_{IN} \cdot T_{ON})_{max}$ can raise the maximum limit on L_M . Take care not to go above $(V_{IN} \cdot T_{ON})_{limit}$. Also, keep in mind that if equation 10.7 and 10.8 are not met then $(V_{IN} \cdot T_{ON})_{max}$ does not occur at full load and lowest input voltage, thus some of the equations here would be invalid.

10.7 Primary Winding

In order to keep the transformer from saturation, the maximum flux density must not be exceeded. Therefore the minimum primary winding must meet:

$$N_{PRI} \geq \frac{(V_{IN} \cdot T_{ON})_{\max}}{B_{\max} \times A_e} \quad (10.13)$$

Where B_{\max} is maximum allowed flux density and A_e is the core area. From the transformer core datasheet we find that for this example B_{\max} is 320 mT. For an RM6 core, A_e is 35 mm².

$$N_{PRI} \geq \frac{399V \cdot \mu s}{320mT \times 35mm^2} = 36$$

For this example, we choose 75 primary turns.

10.8 Secondary Winding

From the primary winding turns, we obtain the secondary winding.

$$N_{SEC} = \frac{N_{PRI}}{N_{TR}} \quad (10.14)$$

Thus, in our example:

$$N_{SEC} = \frac{75}{2.5} = 30$$

10.9 Bias Winding and V_{CC} Capacitance

V_{CC} is the supply to the iW3620 and should be below 16 V. The bias winding needs to ensure that V_{CC} does not exceed 16 V during normal operation.

$$N_{BIAS} = \frac{N_{SEC} (V_{CC} + V_{FD})}{V_{OUT}} \quad (10.15)$$

Set V_{CC} at around 11 V

$$N_{BIAS} = \frac{30(11V + 0.5)}{23.6} = 15$$

Choose a value for N_{BIAS} to be close to this number, for this example we choose 15 turns.

The V_{CC} capacitor ($C_{V_{CC}}$) stores the V_{CC} charge during IC operation and the controller checks this voltage and makes sure it is within range before starting and operating. The startup time is a function of how quickly this capacitor can charge up.

$$t_{START-UP} = \frac{C_{V_{CC}} \times V_{CC(ST)}}{\frac{V_{INAC} \times \sqrt{2}}{R_{V_{in}}} - I_{INST}} \quad (10.16)$$

10.10 V_{SENSE} Resistors and Winding

The output voltage regulation is mainly determined by the feedback signal V_{SENSE} .

$$V_{SENSE} = V_{OUT_PCB} \times K_{SENSE} \quad (10.17)$$

Where:

$$K_{SENSE} = \frac{R_{BV_{sns}}}{(R_{BV_{sns}} + R_{TV_{sns}})} \times \frac{N_{V_{sense}}}{N_{SEC}} \quad (10.18)$$

Internally, V_{SENSE} is compared to a reference voltage $V_{SENSE(nom)}$. Where, $V_{SENSE(nom)}$ is 1.538 V.

$$K_{SENSE} = \frac{V_{SENSE(nom)}}{V_{OUT_PCB}} \quad (10.19)$$

$$K_{SENSE} = \frac{1.538V}{23.6V} = 0.065$$

From here we can find the ratio necessary for $R_{BV_{sns}}$ and $R_{TV_{sns}}$. For this example we set $R_{TV_{sns}}$ to be 20 k Ω . Assuming we use the same winding for both V_{SENSE} and V_{CC} :

$$0.065 = \frac{R_{BV_{sns}}}{(R_{BV_{sns}} + 20k\Omega)} \times \frac{15}{30}$$

$$\therefore R_{BV_{sns}} = 3.0k\Omega$$

At this point the transformer design is complete. This would be a good time to confirm that this transformer is feasible to build.

10.11 Current Sense Resistor

The I_{SENSE} resistor determines the maximum current output of the power supply. The output current of the power supply is determined by:

$$I_{OUT} = \frac{1}{2} \times N_{TR} \times I_{PRI(pk)} \times \frac{T_{RESET}}{T_{PERIOD}} \times \eta_X \quad (10.20)$$

When the maximum current output is achieved the voltage seen on the I_{SENSE} pin ($V_{I_{sense}}$) should reach its maximum. Thus, at constant current limit:

$$I_{PRI(pk)} = \frac{V_{I_{sense(CC)}}}{R_{I_{sense}}} \quad (10.21)$$

Substituting this into equation 10.20 we get:

$$V_{I_{sense(CC)}} = \frac{T_{PERIOD}}{T_{RESET}} \times K_C \quad (10.22)$$

For iW3620 K_C is 0.5 V, therefore $R_{I_{sense}}$ depends on the maximum output current by;

$$R_{I_{sense}} = \frac{N_{TR} \times K_C}{2 \times I_{OUT(nom)}} \times \eta_X \quad (10.23)$$

From Table 10.1 $I_{OUT(nom)}$ is given to be 0.5 A, therefore R_{Isense} is:

$$R_{Isense} = \frac{2.5 \times 0.5V}{2 \times 0.5A} \times 0.87 = 1.08\Omega$$

We recommend using $\pm 1\%$ tolerance resistors for R_{Isense} .

10.12 Input Bulk Capacitor

The input bulk capacitor, C_{BULK} is chosen to maintain enough input power to sustain constant output power even as the input voltage is dropping. In order for this to be true C_{BULK} must be:

$$C_{BULK} = \frac{2 \times P_{IN} \times \left[0.25 + \frac{1}{2\pi} \times \arcsin\left(\frac{V_{INDC(min)}}{\sqrt{2} \times V_{INAC(min)}}\right) \right]}{\left(2 \times V_{INAC(min)}^2 - V_{INDC(min)}^2 \right) \times f_{line}} \quad (10.24)$$

$$P_{IN} = \frac{V_{OUT(Cable)} \times I_{OUT}}{\eta_{power\ supply}}$$

$V_{INAC(min)}$ is the minimum input voltage (rms) to be inputted into the power supply and f_{line} is the lowest line frequency for the power supply (in this case 47 Hz). $V_{INDC(min)}$ is determined in Section 10.5 to be 80 V.

$$P_{IN} = \frac{23.6V \times 0.5A}{0.85} = 13.88W$$

$$C_{BULK} = \frac{2 \times 13.88W \times \left[0.25 + \frac{1}{2\pi} \times \arcsin\left(\frac{80V}{\sqrt{2} \times 85V_{AC}}\right) \right]}{\left(2 \times 85^2 - 80^2 \right) \times 47} = 22\mu F$$

For this example C_{BULK} is chosen to be 47 μF .

10.13 Output Capacitance

The output capacitance affects both the steady state ripple and the dynamic response of the power supply.

Assuming an ideal capacitor where ESR (equivalent series resistance) and ESL (equivalent series inductance) are negligible then:

$$C_{OUT(Steady\ State)} = \frac{Q_{OUT}}{V_{OUT(ripple)}} \quad (10.25)$$

The output capacitor supplies the load current when the secondary current is below the output current.

$$Q_{OUT} = \frac{L_M \times \left(I_{SEC(pk)} - I_{OUT(nom)} \right)^2}{2 \times N_{TR}^2 \times \eta_X \times V_{OUT}} \quad (10.26)$$

The $I_{SEC(pk)}$ is:

$$I_{SEC(pk)} = \frac{\left(V_{IN} \cdot T_{ON} \right)_{MAX}}{L_M} \times N_{TR} \times \eta_X \quad (10.27)$$

So to keep $V_{OUT(ripple)}$ to be 100 mV,

$$I_{SEC(pk)} = \frac{399V \cdot \mu s}{0.438mH} \times 2.5 \times 0.87 = 1.98A$$

$$Q_{OUT} = \frac{0.438mH \times \left(1.98A - 0.5A \right)^2}{2 \times 2.5^2 \times 0.87 \times 23.6V} = 3.74\mu C$$

$$C_{OUT(Steady\ State)} = \frac{3.74\mu C}{100mV} = 37\mu F$$

The actual ripple is higher than the above calculations suggest, because the calculations do not include ESR.

Assume that the load transient goes from no load to $I_{OUT(HIGH)}$. Then from Section 9.4, equation 9.8 we find that the relationship between output capacitance ($C_{OUT(Dynamic)}$) and $V_{DROP(IC)}$ is:

$$C_{OUT(Dynamic)} = \frac{I_{OUT(HIGH)} \times T_{P(No\ load)}}{V_{DROP(IC)}} \quad (10.28)$$

Then solving for $V_{DROP(IC)}$, where $V_{Dynamic(DROP)}$ is the maximum allowable drop in voltage for the design during dynamic response, and $V_{DROP(sense)}$ is the drop in voltage before V_{SENSE} signal is low enough to register a dynamic transient.

$$C_{OUT(Dynamic)} = \frac{I_{OUT(HIGH)} \times T_{P(No\ load)}}{V_{Dynamic(Drop)} - V_{DROP(sense)}} \quad (10.29)$$

Where $T_{P(No\ load)}$ is the maximum period under no load condition, given by equation 10.30:

$$T_{P(No\ load)} = \frac{R_{Preload} \times \left(V_{IN} \cdot T_{ON} \right)_{PFM}^2}{2 \times L_M \times V_{OUT}^2} \times \eta_{No\ load} \quad (10.30)$$

Assume that we want no more than 2.0 V drop on $V_{OUT(PCB)}$ during load transient from no load to 100% load and the efficiency of the power supply at no load ($\eta_{No\ load}$) is 50%, then $C_{OUT(Dynamic)}$ is:

$$T_{P(No\ load)} = \frac{20k\Omega \times \left(131V \cdot \mu s \right)^2}{2 \times 0.438mH \times 23.6V^2} \times 0.5 = 352\mu s$$

$$V_{DROP(sense)} = \left(1.538V - 1.48V \right) \times \frac{23.6V}{1.538V} = 0.890V$$

Plug everything into equation 10.29:

$$C_{OUT(Dynamic)} = \frac{0.5A \times 352\mu s}{\left(2V - 0.890V \right)} = 159\mu F$$

Pick the larger capacitance value between $C_{OUT(Dynamic)}$ and $C_{OUT(Steady\ State)}$. In this case C_{OUT} is chosen to be 470 μF .

10.14 Snubber Network

The snubber network is implemented to reduce the voltage stress on the MOSFET immediately following the turn off of the gate drive. The goal is to dissipate the energy from the leakage inductance of the transformer. For simplicity and a more conservative design first assume the energy of the leakage inductance is only dissipated through the snubber. Thus:

$$\frac{1}{2} \times L_{lk} \times I_{PRI(pk)}^2 = \frac{1}{2} \times C_{SNUB} \times [V_{Snub(pk)}^2 - V_{Snub(val)}^2] \quad (10.31)$$

L_{lk} can be measured from the transformer. $V_{Snub(pk)}$ and $V_{Snub(val)}$ refer to the voltage measured across the snubber capacitor. Choose a C_{SNUB} , keeping in mind that the larger the value of C_{SNUB} the lower the voltage stress is on the MOSFET. However, capacitors are more expensive the larger their capacitance. Choose C_{SNUB} based on these two criteria and select $V_{Snub(pk)}$ and $V_{Snub(val)}$. Now a resistor needs to be selected to dissipate $V_{Snub(pk)}$ to $V_{Snub(val)}$ during the on-time of the gate driver. The dissipation of this resistor is given by:

$$\frac{V_{Snub(val)}}{V_{Snub(pk)}} = e^{-T_P(\min op) / R_{SNUB} \times C_{SNUB}} \quad (10.32)$$

Using equation 10.32 solve for R_{SNUB} . This gives a conservative estimate of what C_{SNUB} and R_{SNUB} should be.

Included in the snubber network is also a resistor in series with a diode. The diode directs current to the snubber capacitor when the MOSFET is turned off; however there is some reverse current that goes through the diode immediately after the MOSFET is turned back on. This reverse current occurs because there is a short period of time when the diode still conducts after switching from forward biased to reverse biased. This conduction distorts the falling edge of the V_{SENSE} signal and affects the operation of the IC. So, the resistor in series with the diode is there to diminish the reverse current that goes through the diode immediately after the MOSFET is turned on.

10.15 T_{ON} Delay Filter

iW3620 also contains a feature that allows for adjustment to match high line and low line constant current curves. The mismatch in high line and low line is due to the delay from the IC propagation delay, driver turn-on delay, and the MOSFET turn-on delay. The driver turn-on delay maybe further increased by a gate resistor to the MOSFET. To adjust for these delays the iW3620 factors these delays into its calculations and slightly over compensates for them to provide flexibility. R_{Dly} and C_{Dly} provide extra delay in the circuit to tweak the compensation. To determine values R_{Dly} and C_{Dly} follow these steps:

1. Measure the difference between high line and low line constant current limit without filter components.
2. Find the curve that best matches this difference from Figure 11.1.
3. Find the L_M that matches the power supply, and find the τ_{RC} .
4. Find R_{Dly} and C_{Dly} from equation 10.33

$$\tau_{RC} = R_{Dly} \times C_{Dly} \quad (10.33)$$

10.16 SD Protection

The SD pin can be configured to provide three different types of protection: OTP protection, OVP protection and both OVP and OTP Protection. Figure 10.3 shows the three configurations plus the configuration for no OTP and OVP protection.

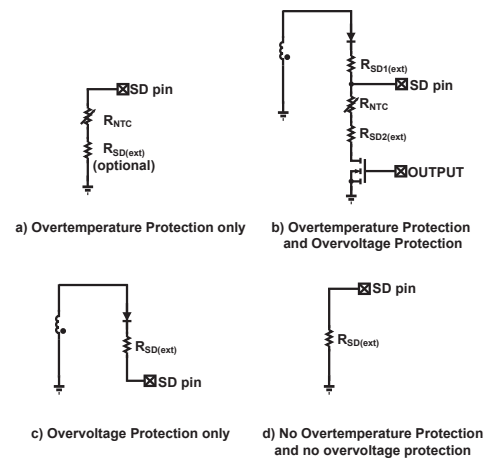

Figure 10.3 : SD Pin Application Configurations

OTP Only

To detect an overtemperature protection the iW3620 sends a 107 μ A current (I_{SD}) to the SD pin every four cycles (see Section 9.13). On the last cycle the iW3620 observes the voltage on the SD pin and detects an OTP fault if the voltage is lower than V_{SD-TH} , 1.0 V during normal operation and 1.2 V during startup. So $R_{SD(ext)}$ in series with NTC must meet

$$(R_{NTC} + R_{SD(ext)}) \times I_{SD} > V_{SD-TH} \quad (10.34)$$

in order not to trigger OTP fault during normal operation.

OVP Only

For the other four cycles, the iW3620 connects the SD pin to R_{SD} to ground (see Section 9.13). At the last cycle the iW3620 observes the voltage on the SD pin and detects an

OVP fault if the voltage is higher than V_{SD-TH} , 1 V. In order to not trigger OVP fault, assuming 0 V drop across the series diode, $R_{SD(ext)}$ must meet:

$$\frac{V_{OUT_PCB}}{N_{SEC}} \times N_{AUX} \times \frac{R_{SD}}{R_{SD} + R_{SD(ext)}} < V_{SD-TH} \quad (10.35)$$

where, $R_{SD} = 8.333 \text{ k}\Omega$

Both OTP and OVP

To find $R_{SD1(ext)}$ so that OVP can be detected, use equation 10.35. To find $R_{SD2(ext)}$ in series with the NTC use equation 10.34.

No OTP and OVP

If OTP and OVP from the SD pin are not needed, simply place a resistor, $R_{SD(ext)}$ to ground from the SD pin. Make sure $R_{SD(ext)}$ meets equation 10.36 so OTP protection does not trip.

$$R_{SD(ext)} \times I_{SD} > V_{SD-TH} \quad (10.36)$$

Note that this means OVP is not detected through the SD pin; however, OVP from V_{SENSE} pin is still active and the iW3620 still shuts down if overvoltage condition is detected.

Since for this example OTP and OVP are not necessary we place a resistor from SD pin to ground and calculate its value from equation 10.36.

$$R_{NTC} > 1.2V / 100\mu A = 12k\Omega$$

10.17 PCB Layout

In the iW3620, there are two signals that are important to control the output performance; these are the I_{SENSE} signal and the V_{SENSE} signal. The I_{SENSE} resistor should be close to the source of the MOSFET to avoid any trace resistance from contaminating the I_{SENSE} signal. Also, the I_{SENSE} signal should be placed close to the I_{SENSE} pin. The V_{SENSE} signal should be placed close to the transformer to improve the quality of the sensing signal. Also for better output performance all bypass capacitors should be placed close to their respective pins.

To reduce EMI, switching loops need to be minimized. These loops include (see Figure 10.4):

1. The input bulk capacitor, primary winding, MOSFET and R_{Isense} loop.
2. The output diode, output capacitor and secondary winding loop.
3. V_{CC} winding and rectifier diode loop.

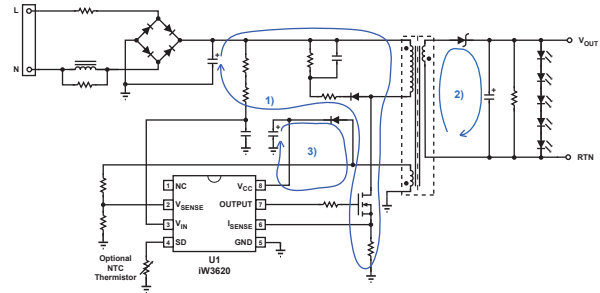

Figure 10.4 : Switching Loops

To improve ESD performance provide a low impedance path from the ground pin of the transformer to the ac power source and make sure this path does not go through the IC ground pin. A discharge spark gap helps to transfer ESD and EOS energy from the secondary side of the power supply directly to the external ac power source.

In a switch-mode power supply there are several ground signals, namely: the power ground, the switching ground and the control logic ground. These ground signals should be connected by a star connection. Ground traces should be kept as short as possible. A thick trace on the switching ground helps to lessen switching losses.

11.0 Performance Characteristics

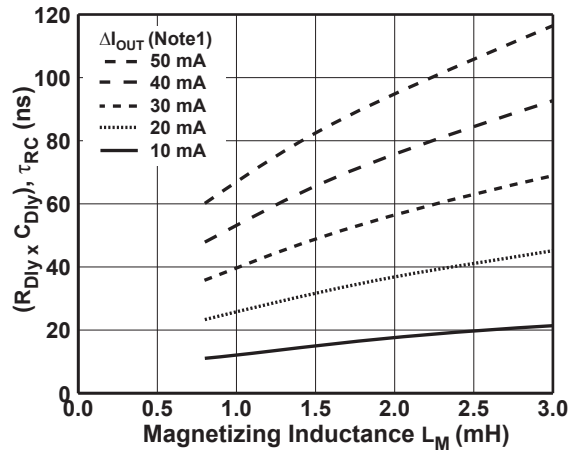

Figure 10.5 : T_{ON} Compensation Chart

12.0 Application Circuit

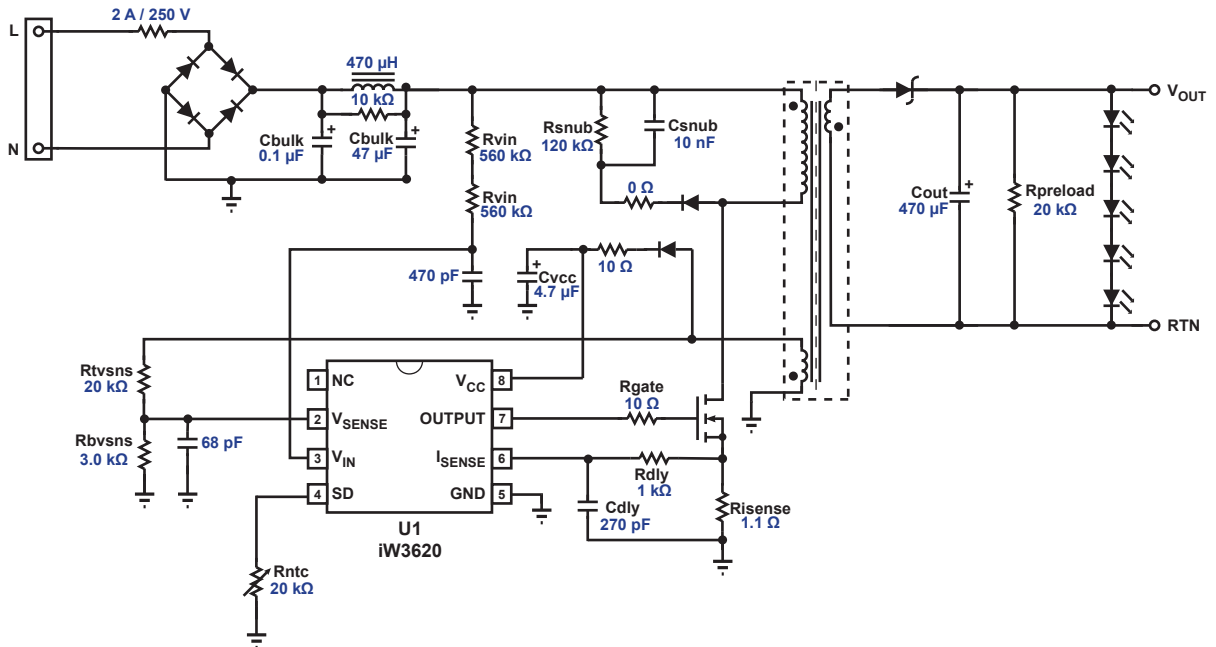

Figure 12.1 : Typical Application Circuit

Note 1: ΔI_{OUT} refers to the difference in constant current limit between 264 V_{ac} and 90 V_{ac} when no R_{DLY} and C_{DLY} are applied.

13.0 Physical Dimensions

8-Lead Small Outline (SOIC) Package

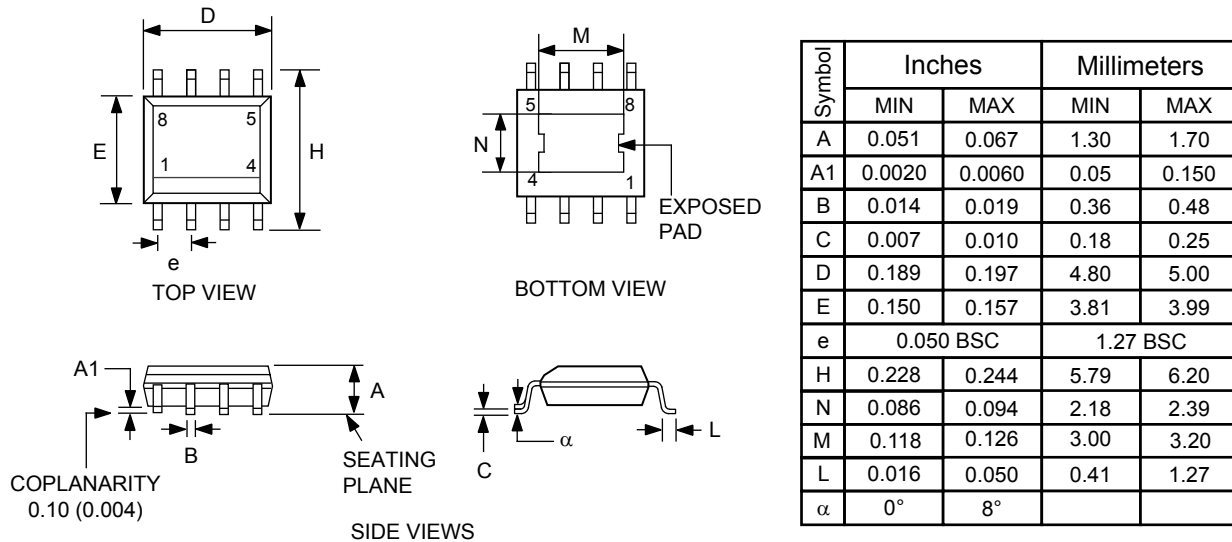

Figure 13.1 : Physical dimensions, 8-lead SOIC package

Compliant to JEDEC Standard MS12F

Controlling dimensions are in inches; millimeter dimensions are for reference only

This product is RoHS compliant and Halide free.

Soldering Temperature Resistance:

[a] Package is IPC/JEDEC Std 020D Moisture Sensitivity Level 3

Dimension D does not include mold flash, protrusions or gate burrs. Mold flash, protrusions or gate burrs shall not exceed 0.15 mm per end. Dimension E does not include interlead flash or protrusion. Interlead flash or protrusion shall not exceed 0.25 mm per side.

The package top may be smaller than the package bottom. Dimensions D and E are determined at the outermost extremes of the plastic body exclusive of mold flash, tie bar burrs, gate burrs and interlead flash, but including any mismatch between the top and bottom of the plastic body.

14.0 Ordering Information

Part Number	Package	Description
iW3620-00	SOIC-8	Tape & Reel ¹

Note 1: Tape & Reel packing quantity is 2,500/reel.

iW3620

Digital PWM Current-Mode Controller for AC/DC LED Driver



About iWatt

iWatt Inc. is a fabless semiconductor company that develops intelligent power management ICs for computer, communication, and consumer markets. The company's patented *pulseTrain*™ technology, the industry's first truly digital approach to power system regulation, is revolutionizing power supply design.

Trademark Information

© 2008 iWatt, Inc. All rights reserved. iWatt, the iW light bulb, *EZ-EMI* and *pulseTrain* are trademarks of iWatt, Inc. All other trademarks and registered trademarks are the property of their respective companies.

Contact Information

Web: <http://www.iwatt.com>

E-mail: info@iwatt.com

Phone: 408-374-4200

Fax: 408-341-0455

iWatt Inc.

101 Albright Way
Los Gatos CA 95032-1827

Disclaimer

iWatt reserves the right to make changes to its products and to discontinue products without notice. The applications information, schematic diagrams, and other reference information included herein is provided as a design aid only and are therefore provided as-is. iWatt makes no warranties with respect to this information and disclaims any implied warranties of merchantability or non-infringement of third-party intellectual property rights.

Certain applications using semiconductor products may involve potential risks of death, personal injury, or severe property or environmental damage ("Critical Applications").

IWATT SEMICONDUCTOR PRODUCTS ARE NOT DESIGNED, INTENDED, AUTHORIZED, OR WARRANTED TO BE SUITABLE FOR USE IN LIFE-SUPPORT APPLICATIONS, DEVICES OR SYSTEMS, OR OTHER CRITICAL APPLICATIONS.

Inclusion of iWatt products in critical applications is understood to be fully at the risk of the customer. Questions concerning potential risk applications should be directed to iWatt, Inc.

iWatt semiconductors are typically used in power supplies in which high voltages are present during operation. High-voltage safety precautions should be observed in design and operation to minimize the chance of injury.