



ERM-3770 77 x 35 DIN Size Digital Tachometer

- ***4 Digits Display***
- ***NPN or PNP input type***
- ***Working with Process Set and Alarm Set value***
- ***Alarm output***
Relay or SSR driver output (It must be determined in order.)
- ***Alarm Set value boundary***
- ***Adjustable decimal point***
- ***Division rate***
- ***0,07Hz to 10000Hz input signal***
- ***Automatic sampling (1 sec. to 16 sec.)***
- ***Programming mode password protection***

ABOUT INSTRUCTION MANUAL

Instruction manual of ERM-3770 Digital Tachometer consists of two main sections. Explanation of these sections are below. Also, there are other sections which include order information and technical specifications of the device. All titles and page numbers in instruction manual are in “**CONTENTS**” section. User can reach to any title with section number.

Installation:

In this section, physical dimensions of the device, panel mounting, electrical wiring, physical and electrical installation of the device to the system are explained.

Operation and Parameters:

In this section user interface of the device, accessing to the parameters, description of the parameters are explained.

Also in these sections, there are warnings to prevent serious injury while doing the physical and electrical mounting or using the device.

Explanation of the symbols which are used in these sections are given below.



This symbol is used for safety warnings. User must pay attention to these warnings.



This symbol is used to determine the dangerous situations as a result of an electric shock. User must pay attention to these warnings definitely.



This symbol is used to determine the important notes about functions and usage of the device.

Contents

1. PREFACE	Page	5
1.1 GENERAL SPECIFICATIONS		
1.2 ORDERING INFORMATION		
1.3 WARRANTY		
1.4 MAINTENANCE		
2. INSTALLATION	Page	7
2.1 GENERAL DESCRIPTION		
2.2 FRONT VIEW AND DIMENSIONS OF ERM-3770 DIGITAL TACHOMETER WITH ALARM OUTPUT		
2.3 FRONT VIEW AND DIMENSIONS OF ERM-3770 DIGITAL TACHOMETER WITHOUT ALARM OUTPUT		
2.4 PANEL CUT-OUT		
2.5 ENVIRONMENTAL RATINGS		
2.6 PANEL MOUNTING		
2.7 INSTALLATION FIXING CLAMP		
2.8 REMOVING FROM THE PANEL		
3. ELECTRICAL WIRING	Page	12
3.1 TERMINAL LAYOUT AND CONNECTION INSTRUCTIONS		
3.2 ELECTRICAL WIRING DIAGRAM		
3.3 VIEW OF THE DEVICE LABEL		
3.4 SUPPLY VOLTAGE INPUT CONNECTION OF THE DEVICE		
3.5 PROCESS INPUT CONNECTION		
3.5.1 PROXIMITY CONNECTION		
3.5.2 SWITCH CONNECTION		
3.6 GALVANIC ISOLATION TEST VALUES OF ERM-3770 DIGITAL TACHOMETER		
3.7 ALARM OUTPUT CONNECTIONS		
3.7.1 RELAY OUTPUT CONNECTION		
3.7.2 SSR DRIVER OUTPUT CONNECTION		
4. FRONT PANEL DEFINITION AND ACCESSING TO THE MENUS	Page	19
4.1 FRONT PANEL DEFINITION OF ERM-3770 DIGITAL TACHOMETER WITH ALARM OUTPUT		
4.2 FRONT PANEL DEFINITION OF ERM-3770 DIGITAL TACHOMETER WITHOUT ALARM OUTPUT		
4.3 OBSERVATION OF THE SOFTWARE REVISION ON THE DISPLAY		
4.4 CHANGING AND SAVING PROCESS SET VALUE		
4.5 PROGRAMMING MODE PARAMETER LIST		
4.6 OPERATION GRAPHICS OF ALARM OUTPUT AND ALARM TYPES		
4.7 EASY ACCESSING DIAGRAM OF PROGRAMMING MODE PARAMETERS		
4.7.1 DEVICE WITH ALARM OUTPUT		
4.7.2 DEVICE WITHOUT ALARM OUTPUT		
4.8 ENTERING TO THE PROGRAMMING MODE, CHANGING AND SAVING PARAMETERS		
5. FAILURE MESSAGES IN ERM 3770 DIGITAL TACHOMETER	Page	29
6. SPECIFICATIONS	Page	30
6. OTHER INFORMATIONS	Page	30

EU DECLARATION OF CONFORMITY

Manufacturer Company Name : Emko Elektronik A.S.

Manufacturer Company Address: DOSAB, Karanfil Sokak, No:6, 16369 Bursa, Turkiye

The manufacturer hereby declares that the product conforms to the following standards and conditions.

Product Name : Digital Tachometer

Model Number : ERM-3770

Type Number : ERM-3770

Product Category : Electrical equipment for measurement, control and laboratory use

Conforms to the following directives :

73 / 23 / EEC The Low Voltage Directive as amended by 93 / 68 / EEC

89 / 336 / EEC The Electromagnetic Compatibility Directive

Has been designed and manufactured to the following specifications :

EN 61000-6-4:2007 EMC Generic Emission Standard for the Industrial Environments

EN 61000-6-2:2005 EMC Generic Immunity Standard for the Industrial Environments

EN 61010-1:2001 Safety Requirements for electrical equipment for measurement, control And laboratory use

When and Where Issued

16th October 2009

Bursa-TURKEY

Authorized Signature

Name : Serpil YAKIN

Position : Quality Manager

1.Preface

ERM-3770 series Digital Tachometers are design for measuring the period in Industry. They can be used in many applications with their easy use, alarm output, universal process input properties. You can easily adapt them to automation systems and mechanical process. Some application fields which they are used are below:

Application Fields

Glass
Plastic
Petro-Chemistry
Automotive, Textile
Machine Production Industries
etc.

Applications

Period measurement
Frequency measurement
Band Speed measurement
Linear or circular movement
Instantaneous Flow rate

1.1 General Specifications

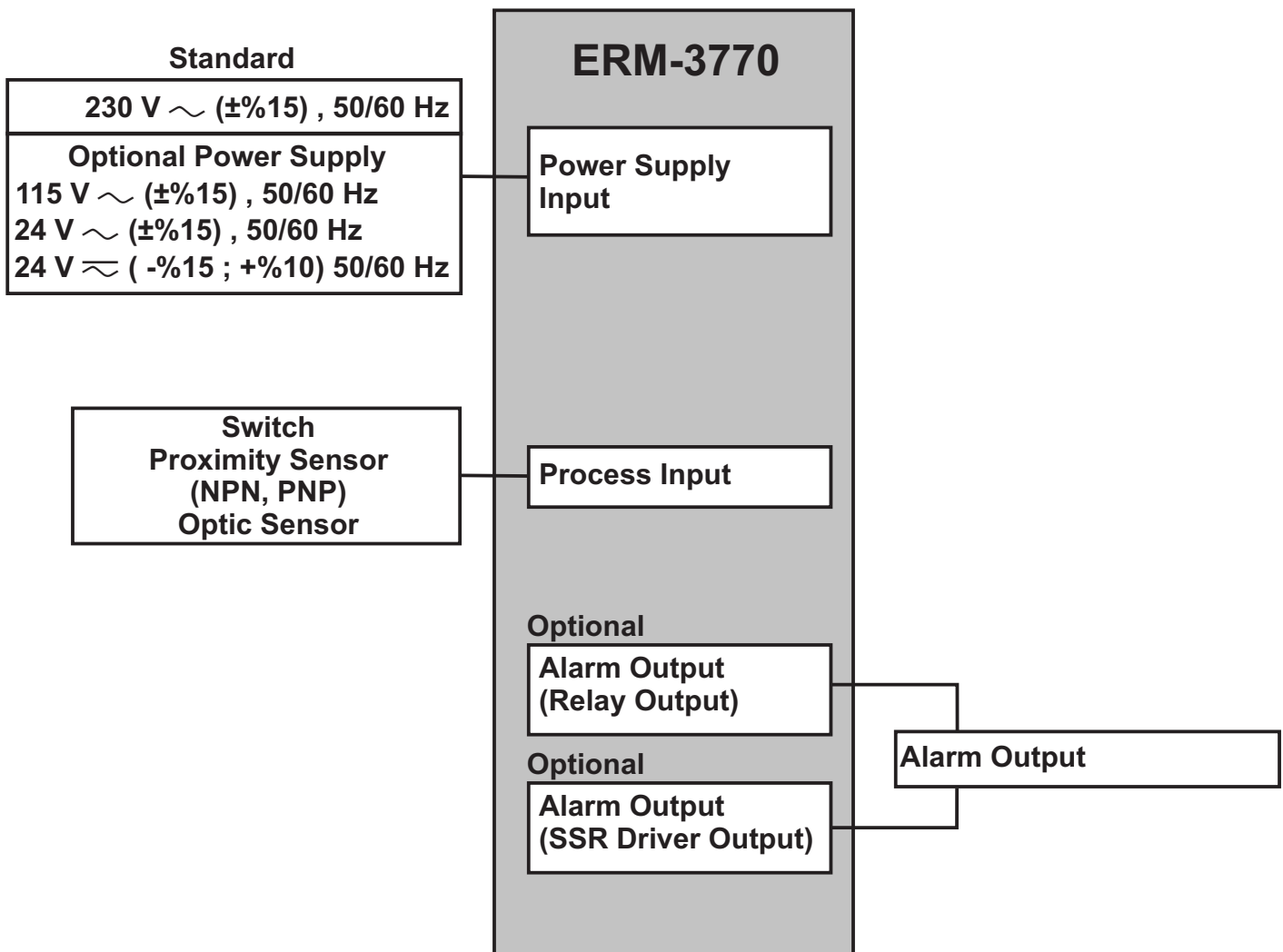

1.2 Ordering Information

Order Information

ERM-3770 (77x35 DIN Size)	A	BC	D	E	/	FG	HI	/	U	V	W	Z
		00	0		/	00	00	/	0	0	0	0

A	Power Supply
2	24 V \sim (-%15 ; +%10) 50/60 Hz
3	24 V \sim (\pm %15) 50/60 Hz
4	115 V \sim (\pm %15) 50/60 Hz
5	230 V \sim (\pm %15) 50/60 Hz
9	Customer

E	Alarm Output
0	None
1	Relay Output (Resistive Load 5A@250V \sim , 1NO + 1NC)
2	SSR Driver Output (Maximum 28mA, 15V \equiv)

All order information of ERM-3770 Digital Tachometer are given on the table at left. User may form appropriate device configuration from information and codes that at the table and convert it to the ordering codes.

Firstly, supply voltage then other specifications must be determined. Please fill the order code blanks according to your needs.

Please contact us, if your needs are out of the standards.



\Rightarrow Vac,



\Rightarrow Vdc can be applied.

1.3 Warranty

EMKO Elektronik warrants that the equipment delivered is free from defects in material and workmanship. This warranty is provided for a period of two years. The warranty period starts from the delivery date. This warranty is in force if duty and responsibilities which are determined in warranty document and instruction manual performs by the customer completely.

1.4 Maintenance

Repairs should only be performed by trained and specialized personnel. Cut power to the device before accessing internal parts.

Do not clean the case with hydrocarbon-based solvents (Petrol, Trichlorethylene etc.). Use of these solvents can reduce the mechanical reliability of the device. Use a cloth dampened in ethyl alcohol or water to clean the external plastic case.

2. Installation



Before beginning installation of this product, please read the instruction manual and warnings below carefully.

In package ,

- One piece unit
- Two pieces mounting clamps
- One piece instruction manual

A visual inspection of this product for possible damage occurred during shipment is recommended before installation. It is your responsibility to ensure that qualified mechanical and electrical technicians install this product.

If there is danger of serious accident resulting from a failure or defect in this unit, power off the system and separate the electrical connection of the device from the system.

The unit is normally supplied without a power supply switch or a fuse. Use power switch and fuse as required.

Be sure to use the rated power supply voltage to protect the unit against damage and to prevent failure.

Keep the power off until all of the wiring is completed so that electric shock and trouble with the unit can be prevented.

Never attempt to disassemble, modify or repair this unit. Tampering with the unit may results in malfunction, electric shock or fire.

Do not use the unit in combustible or explosive gaseous atmospheres.

During the equipment is putted in hole on the metal panel while mechanical installation some metal burrs can cause injury on hands, you must be careful.

Montage of the product on a system must be done with it's fixing clamps. Do not do the montage of the device with inappropriate fixing clamp. Be sure that device will not fall while doing the montage.

It is your responsibility if this equipment is used in a manner not specified in this instruction manual.

2.1 General Description

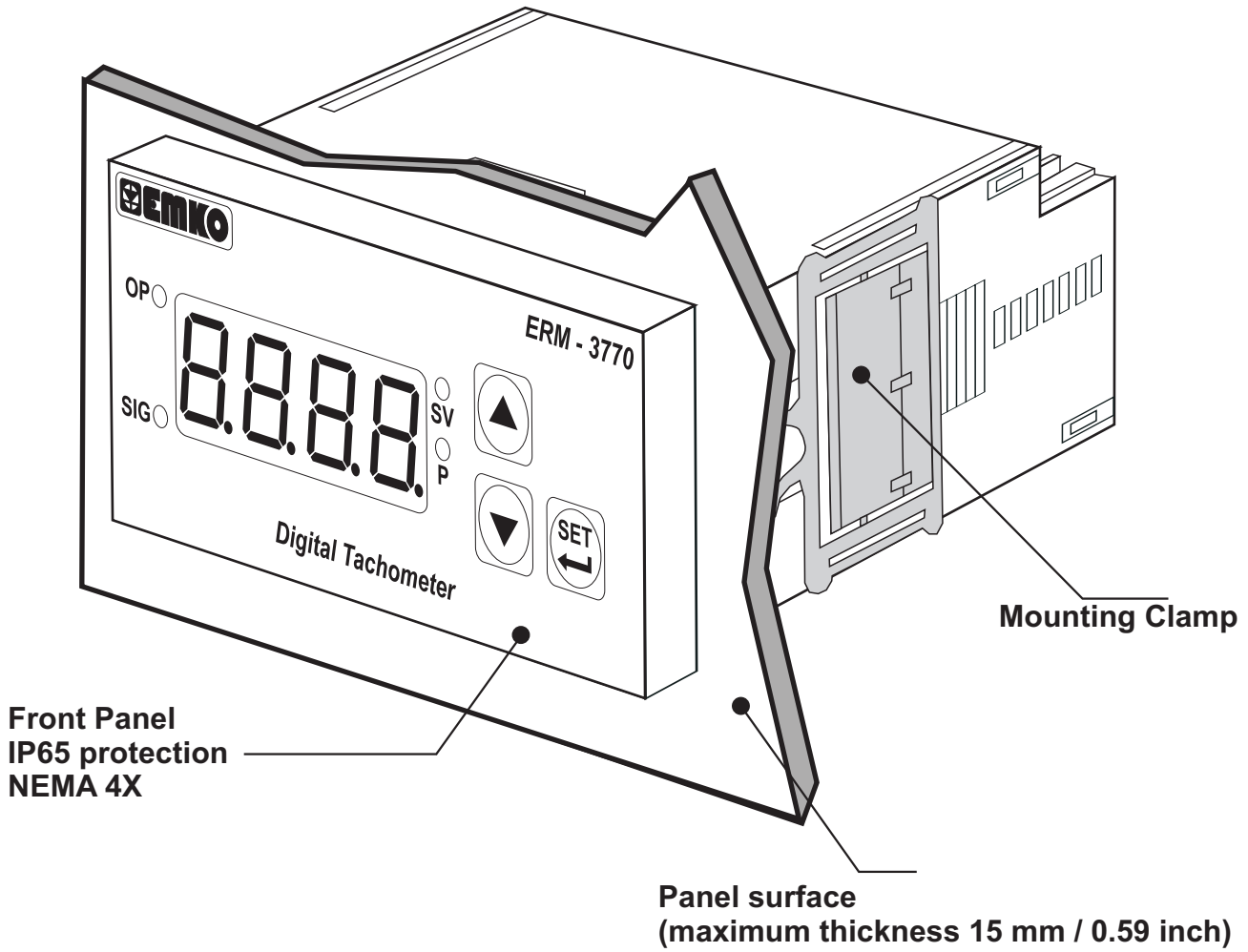

2.2 Front View and Dimensions of ERM-3770 Digital Tachometer With Alarm Output

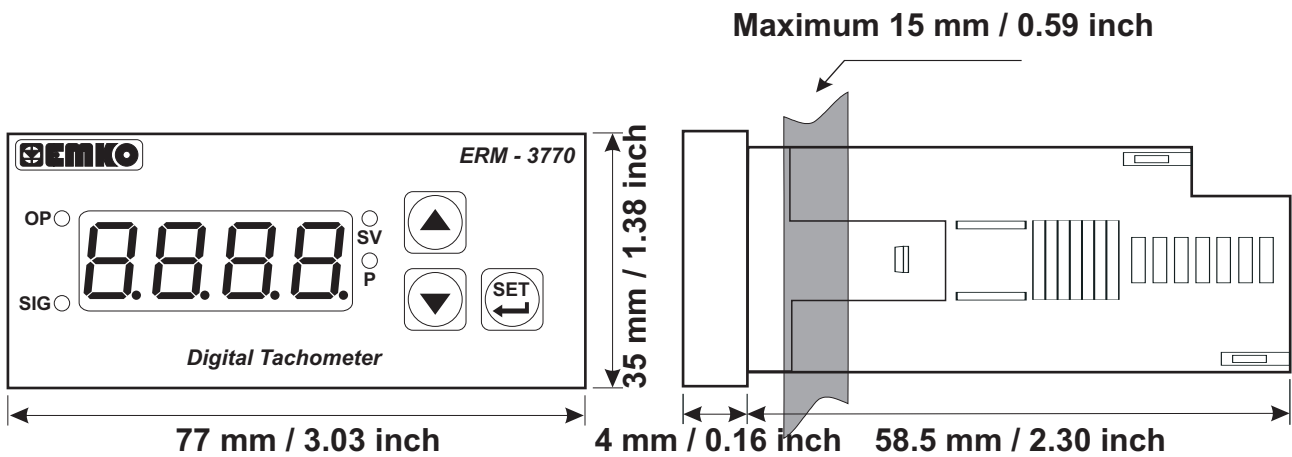

2.3 Front View and Dimensions of ERM-3770 Digital Tachometer Without Alarm Output

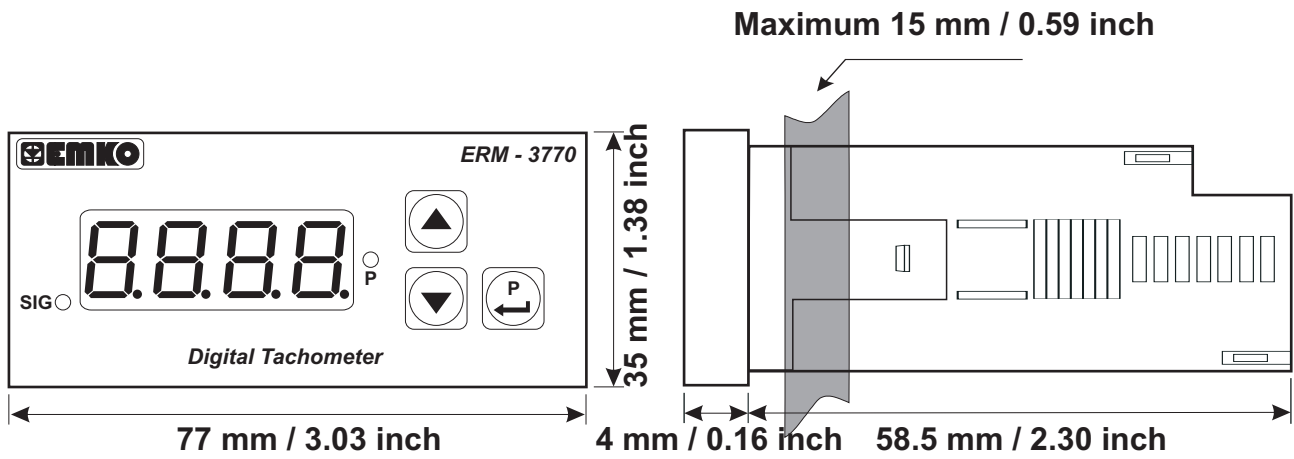

2.4 Panel Cut-Out

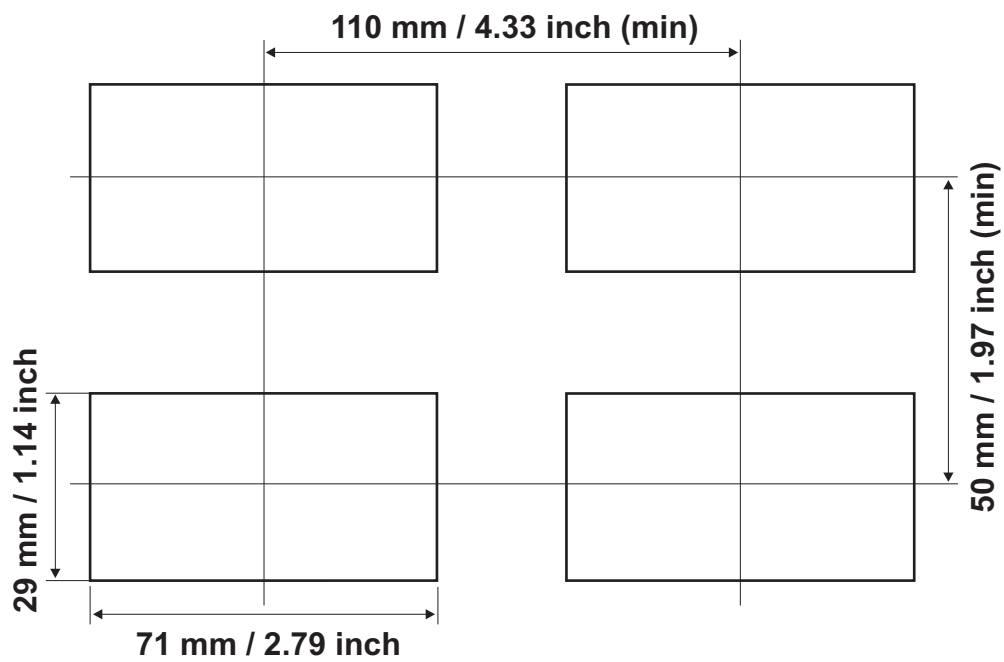

2.5 Environmental Ratings

Operating Conditions



Operating Temperature : 0 to 50 °C



Max. Operating Humidity : 90% Rh (non-condensing)



Altitude : Up to 2000 m.



Forbidden Conditions:

Corrosive atmosphere

Explosive atmosphere

Home applications (The unit is only for industrial applications)

2.6 Panel Mounting

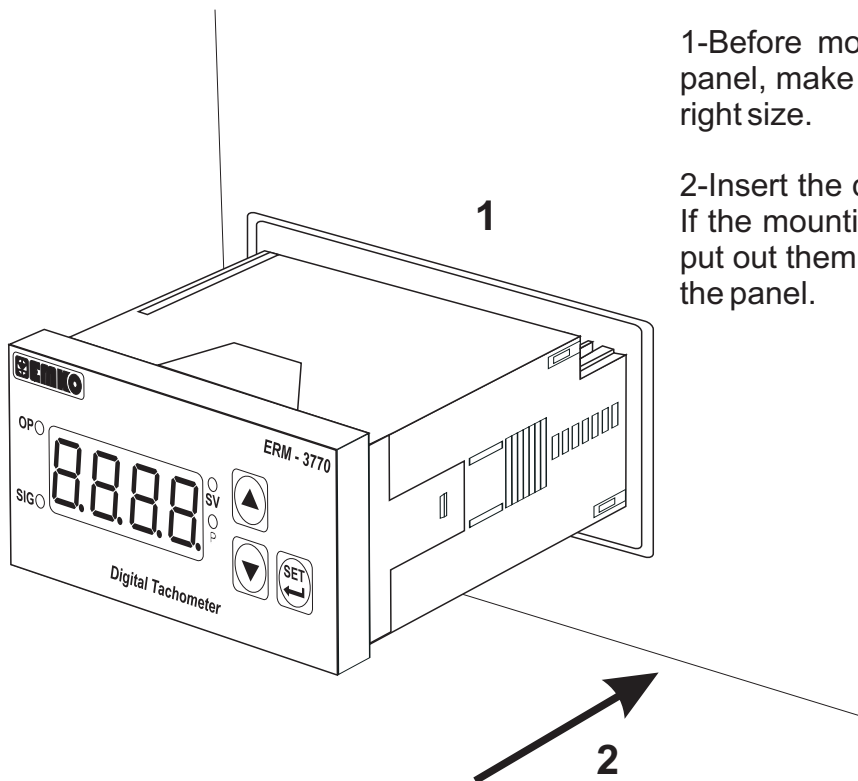

1-Before mounting the device in your panel, make sure that the cut-out is the right size.

2-Insert the device through the cut-out. If the mounting clamps are on the unit, put out them before inserting the unit to the panel.



During installation into a metal panel, care should be taken to avoid injury from metal burrs which might be present. The equipment can loosen from vibration and become dislodged if installation parts are not properly tightened. These precautions for the safety of the person who does the panel mounting.

2.7 Installation Fixing Clamp

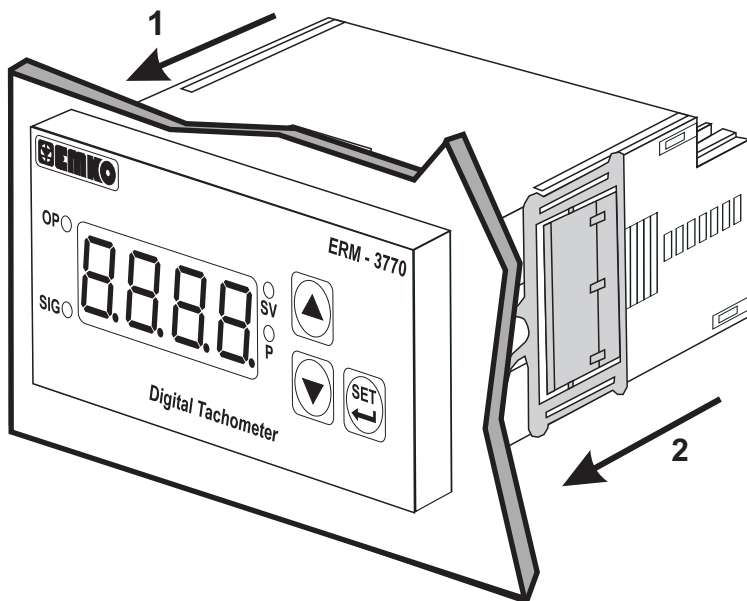

The unit is designed for panel mounting.

1-Insert the unit in the panel cut-out from the front side.

2- Insert the mounting clamps to the fixing sockets that located left and right sides of device and make the unit completely immobile within the panel



Montage of the unit to a system must be done with it's own fixing clamps. Do not do the montage of the device with inappropriate fixing clamps. Be sure that device will not fall while doing the montage.

2.8 Removing from the panel



Before starting to remove the unit from panel, power off the unit and the related system.

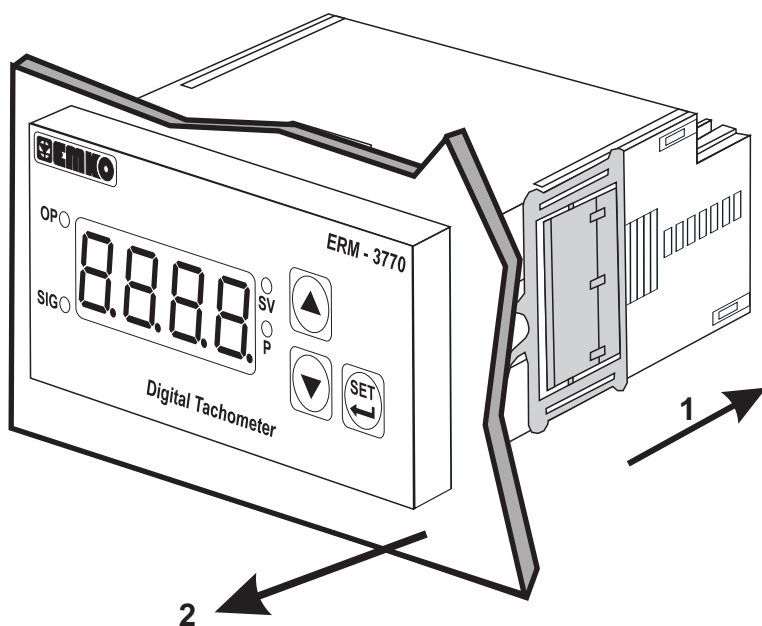

1-Pull mounting clamps from left and right fixing sockets.

2-Pull the unit through the front side of the panel

3. Electrical Wiring



You must ensure that the device is correctly configured for your application. Incorrect configuration could result in damage to the process being controlled, and/or personal injury. It is your responsibility, as the installer, to ensure that the configuration is correct.

Device parameters has factory default values. These parameters must be set according to the system's needs.



Only qualified personnel and technicians should work on this equipment. This equipment contains internal circuits with voltage dangerous to human life. There is severe danger for human life in the case of unauthorized intervention.



Be sure to use the rated power supply voltage to protect the unit against damage and to prevent failure.



Keep the power off until all of the wiring is completed so that electric shock and trouble with the unit can be prevented.

3.1 Terminal Layout and Connection Instructions

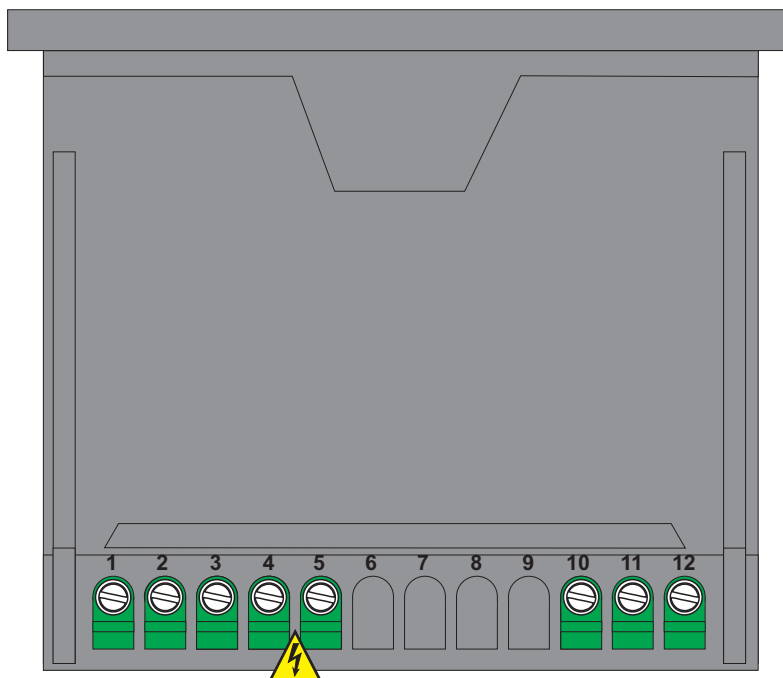

Screw driver
0,8 x3 mm



Torque
0,5 Nm

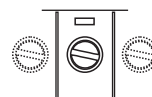

Max. 2.5 mm / 0.098 inch
Wire Size:
14 AWG/1 mm²
Solid /Stranded

3.2 Electrical Wiring Diagram



Electrical wiring of the device must be the same as 'Electrical Wiring Diagram' below to prevent damage to the process being controlled and personnel injury.

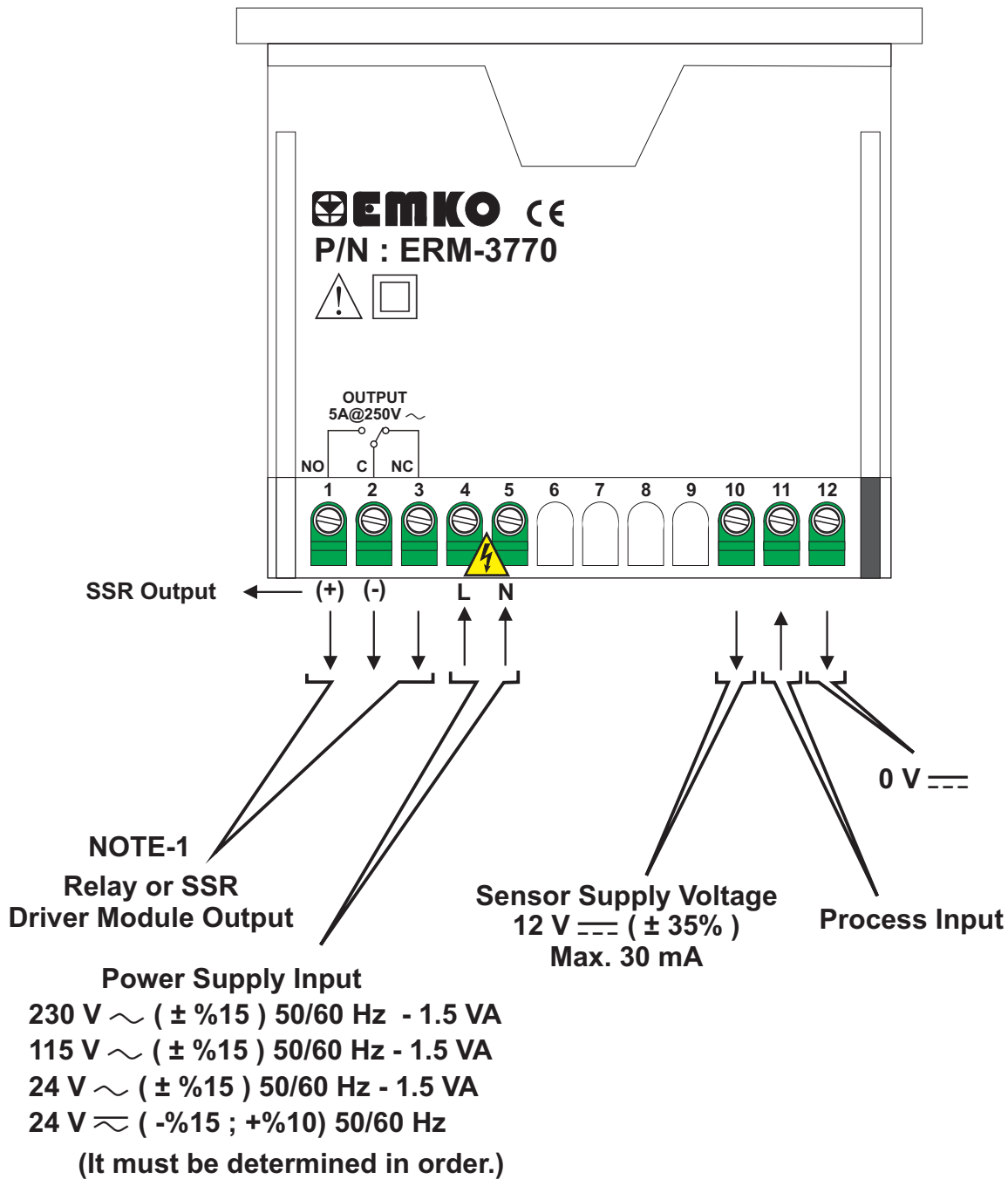

NOTE-1: The output exist in device with Alarm Output.

3.3 View of the Device Label

Device Label for Universal Process Input, 230 V ~ Supply Voltage Input and Relay Output

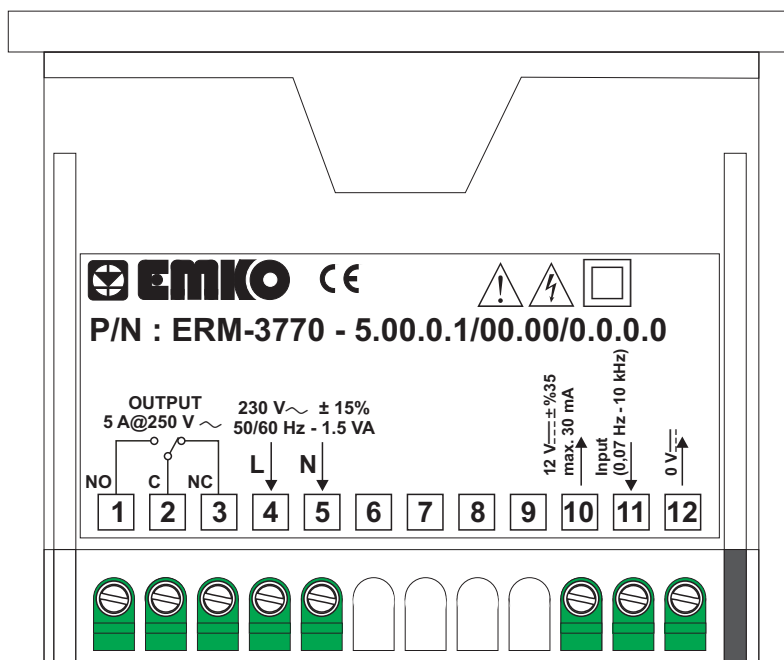

Device Label for Universal Process Input, 230 V ~ Supply Voltage Input Without Alarm Output

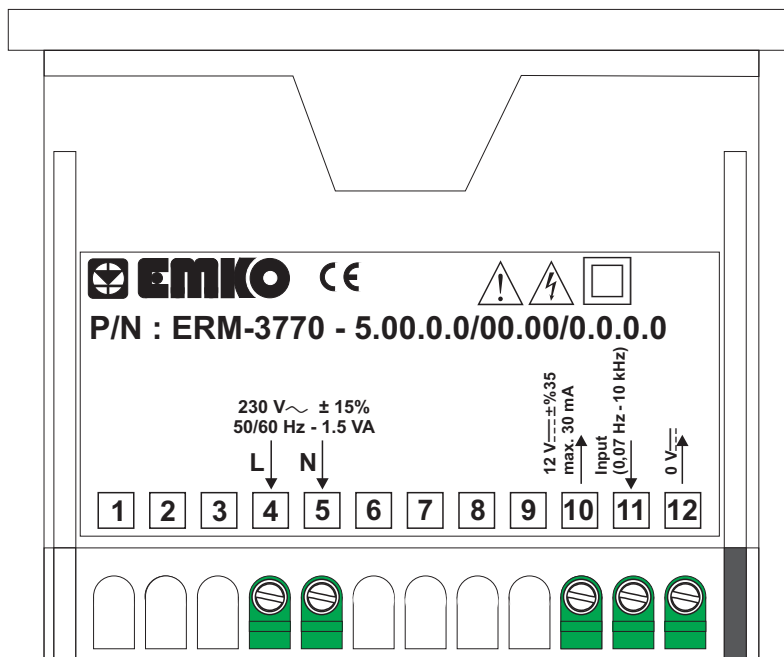

3.4 Supply Voltage Input Connection of the Device

Power Supply Input Connection

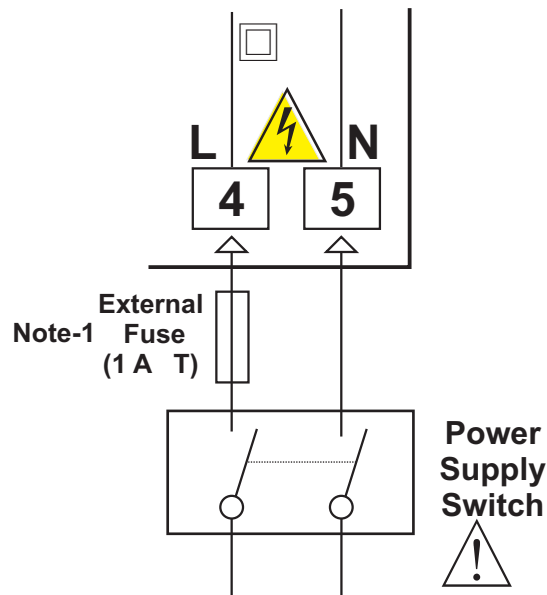

Supply Voltage
230 V \sim (\pm %15) 50/60 Hz or
115 V \sim (\pm %15) 50/60 Hz or
24 V \sim (\pm %15) 50/60 Hz or
24 V \sim (-%15 ; +%10) 50/60 Hz

Note-1: External Fuse is recommended.



Make sure that the power supply voltage is the same indicated on the instrument.

Switch on the power supply only after that all the electrical connections have been completed.



Supply voltage range must be determined in order. Device is produced different for low and high voltage. While installing the unit, supply voltage range must be controlled and appropriate supply voltage must be applied to the unit. Controlling prevents damages in unit and system and possible accidents as a result of incorrect supply voltage.



There is no power supply switch or fuse on the device. So the user must put power supply switch and a fuse to the supply voltage input. In accordance with the safety regulations, the power supply switch shall bring the identification of the relevant instrument. Power supply switch and fuse must be put to a place where user can reach easily.



Power supply switch must be two poled for seperating phase and neutral. On/Off condition of power supply switch is very important in electrical connection. On/Off condition of power supply switch must be signed for preventing the wrong connection.

External fuse must be on phase connection in \sim supply input.

3.5 Process Input Connection

3.5.1 Proximity Connection

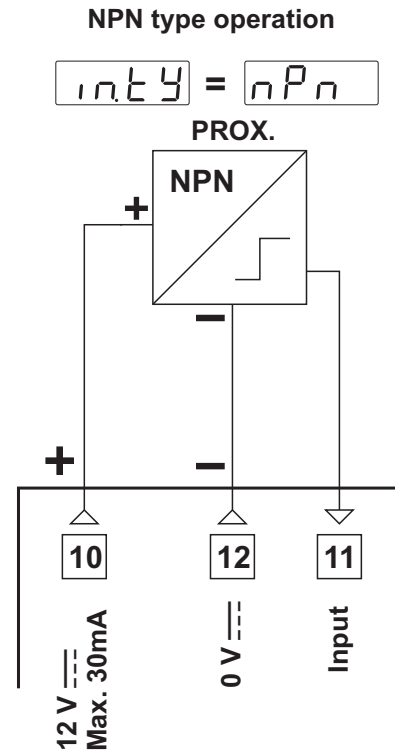
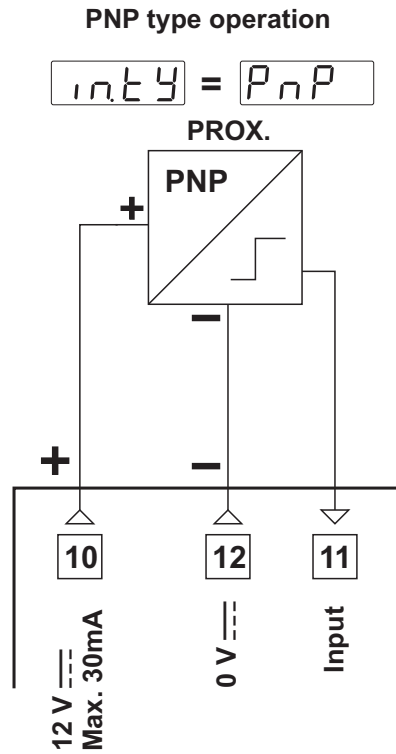

3.5.2 Switch Connection

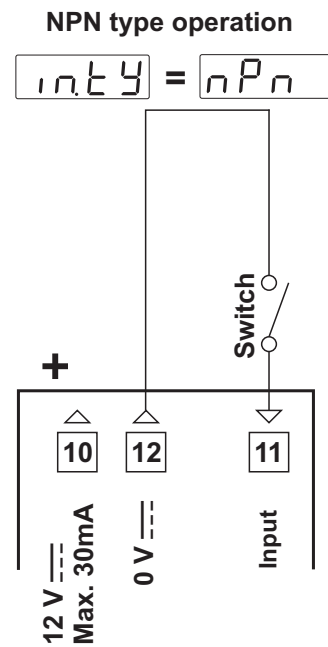
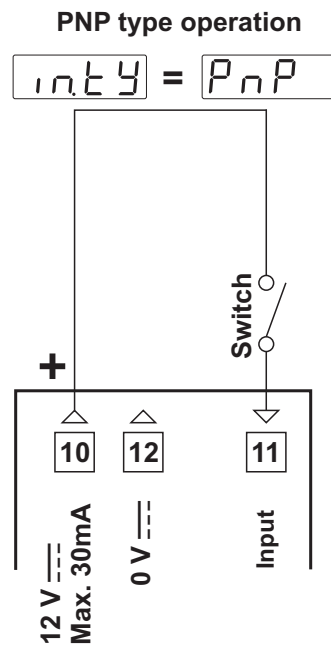

Sensor Supply Voltage is 12 V $\overline{\text{---}}$ \pm %35 maximum 30 mA.

3.6 Galvanic Isolation Test Values of ERM-3770 Digital Tachometer

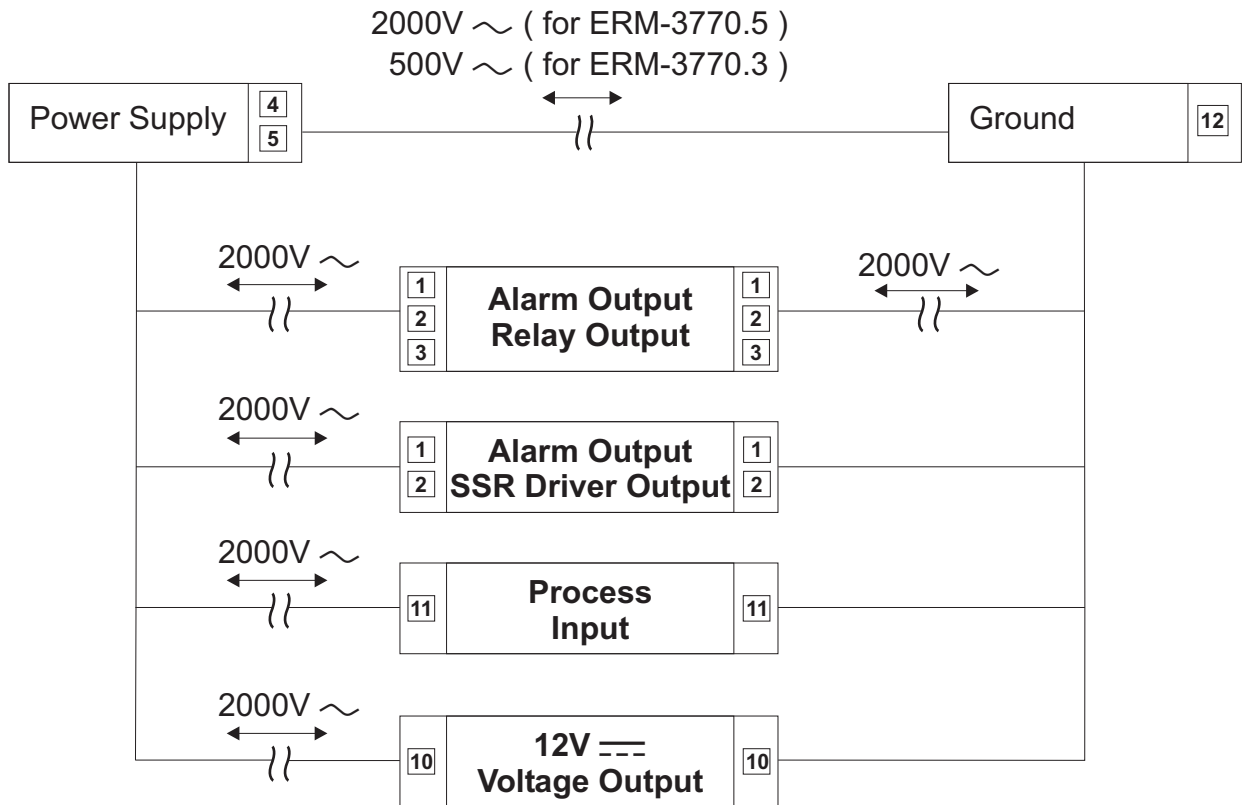

3.7 Alarm Output Connections

3.7.1 Relay Output Connection

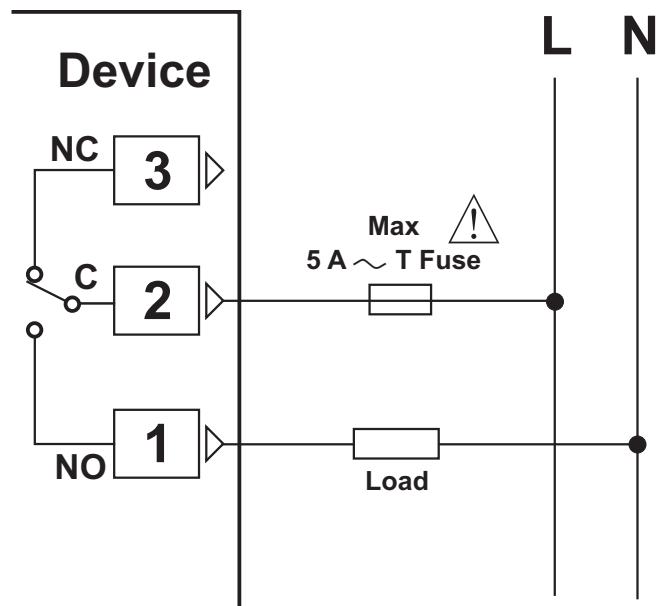

Fuses must be selected according to the application.

3.7.2 SSR Driver Output Connection

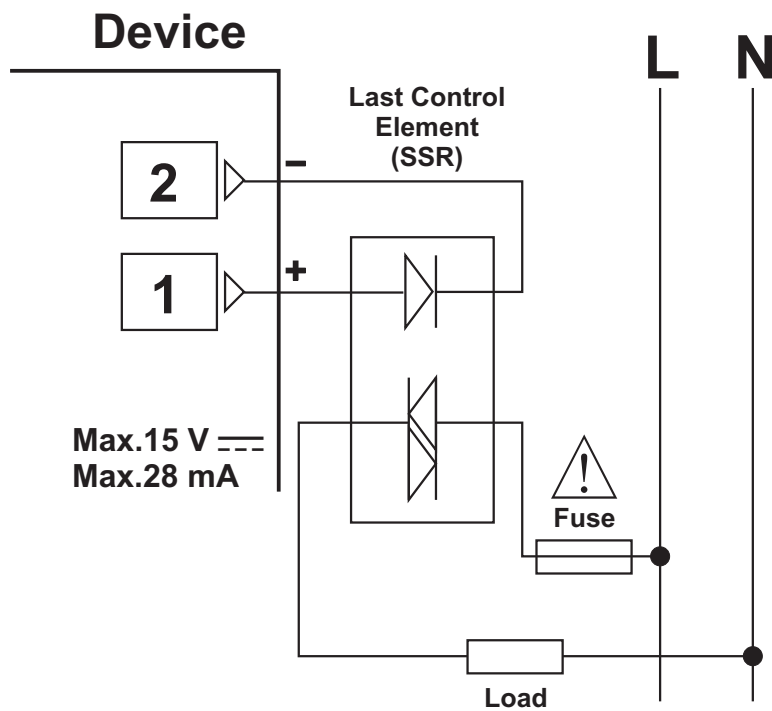

Fuses must be selected according to the application.

4. Front Panel Definition and Accessing to the Menu

4.1 Front Panel Definition of ERM-3770 Digital Tachometer With Alarm Output

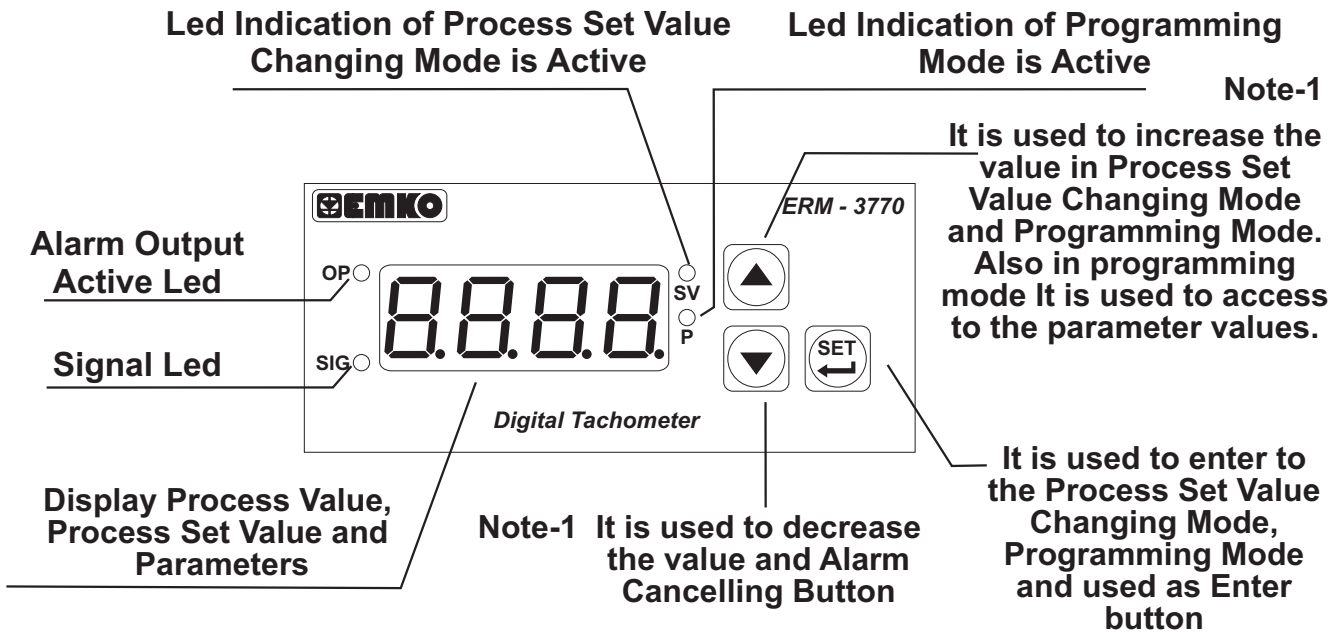

4.2 Front Panel Definition of ERM-3770 Digital Tachometer Without Alarm Output

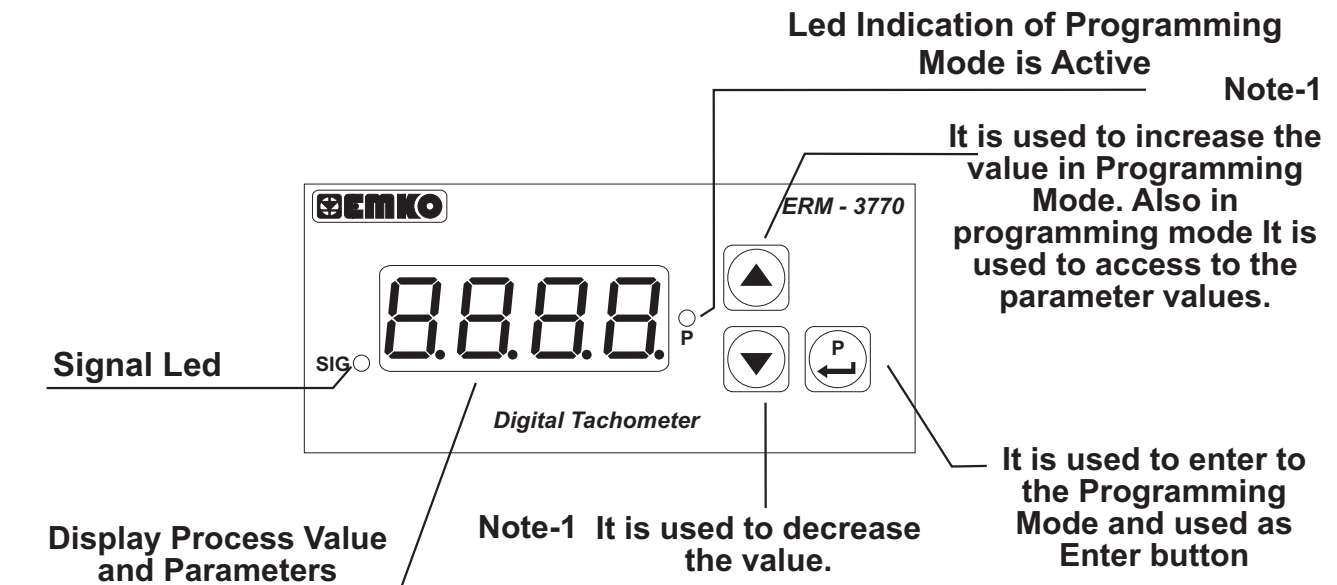

Note-1: If increment or decrement button is pressed for 5 seconds continuously, increment and decrement number become 10, if increment or decrement button is pressed for 10 seconds continuously, increment and decrement number become 100, if increment or decrement button is pressed for 15 seconds continuously, increment and decrement number become 1000.

4.3 Observation of Software Revision on the Display

When power is first applied to the digital process indicator, software revision number is shown on the display.

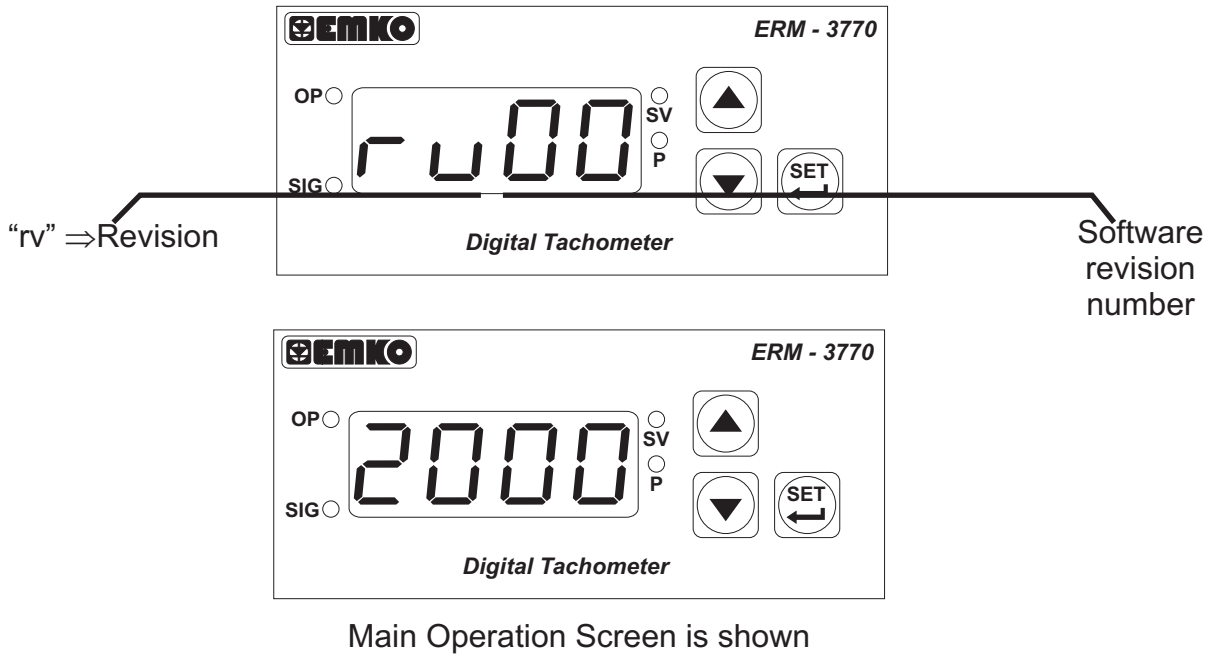

4.4 Changing and Saving Process Set Value

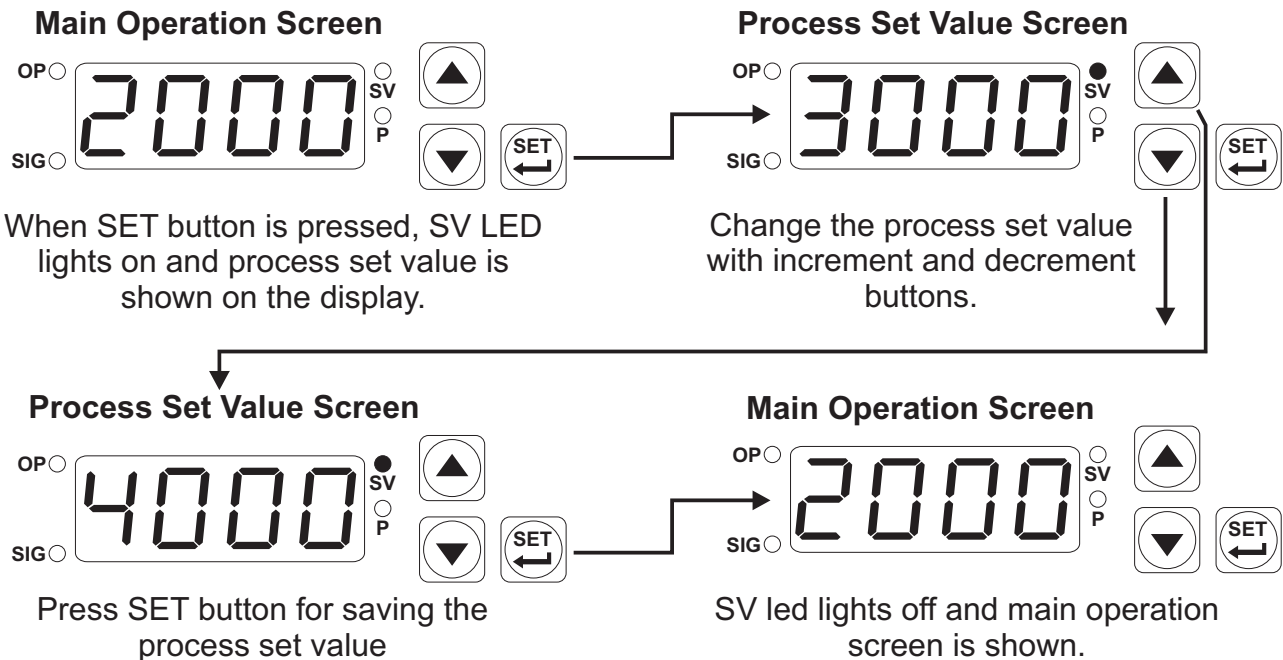

If no operation is performed in Process set value changing mode for 20 seconds, device turns to main operation screen automatically.



Process Set Value changing mode is active, when the device exist Alarm output.

4.5 Programming Mode Parameter List

d 10

Division Rate Parameter (Default = 60)

It can be adjusted from 1 to 999.

Pulse that is applied to the process input of ERM-3770 Digital Tachometer unit is shown according to this parameter. Revolution Per Minute is shown on the screen by dividing with this parameter value. By changing division rate, pulse between 0,07 Hz to 10000 Hz can be observed.

Calculation of division rate:

$$\text{div (Division rate)} = \frac{\text{Revolution Per Minute}}{\text{Value on the Screen}}$$

int4

Input Type Selection Parameter (Default = npn)

nPn NPN type operation is choosen.

PnP PNP type operation is choosen.

AHSt

Alarm Output Hysteresis Parameter (Default = 0)

Hysteresis value of Alarm output.

It can be adjusted from 0 to 5000.

ALtS

Alarm Output Type Selection Parameter (Default = 1)

1 Proses high alarm

2 Proses low alarm

3 Deviation high alarm

4 Deviation low alarm

5 Deviation band alarm

6 Deviation range alarm

ALoL

Alarm Set Value Low Limit Parameter (Default =1)

Alarm set value can not be adjusted under this parameter value.

This parameter can be adjusted from process set value low limit (1) to alarm set value up limit parameter value.

AuPL

Alarm Set Value Up Limit Parameter (Default =9999)

Alarm set value can not be adjusted over this parameter value.

This parameter can be adjusted from alarm set value low limit parameter value to proses set value up limit (9999) value.



If no operation is performed in Process set value changing mode for 20 seconds, device turns to main operation screen automatically.



If the process is not exist Alarm output, then **AHSt**, **ALtS**, **ALoL**, **AuPL**, **ALrt**, **Rond**, **Rofd**, **Ropd** and **ASEt** Parameters is not shown.

ALrt

Alarm Operation type Selection Parameter (Default = 0)

The unit starts to control the alarm output, when the power on.

The unit starts to control the alarm output at the end of the **RoPd** Parameter value.

After the power on and if alarm condition does not seem any more, the unit starts to control the alarm output.

RoNd

Alarm On Delay Time Parameter (Default = 0)

It can be adjusted from 0 to 99 minutes.

RoFd

Alarm Off Delay Time Parameter (Default = 0)

It can be adjusted from 0 to 99 minutes.

When this parameter is 99, if increment button is pressed, **LECH** is observed and alarm latching output is selected. To make the alarm latching output passive, decrement button must be pressed in main operation screen.

RoPd

Alarm Delay Parameter After Power On (Default = 0)

This parameter defines the delay for the alarm is being active after power on. It can be adjusted from 0 to 99 minutes.

ASeT

Alarm Set Value Parameter (Default = 1000)

Alarm output controlled by this parameter. If the **RoTS** parameter is adjusted 1 or 2, then Alarm Set Value can be adjusted from Alarm Set Value Low Limit **ALoL** to Alarm Set Value Up Limit **RUPL**. If the **RoTS** parameter is adjusted 3, 4, 5 or 6 then Alarm Set Value can be adjusted from 0 to Alarm Set Value Up Limit **RUPL** Parameter.

dPnt

Decimal Point Position Parameter (Default = 0)

Decimal Point Position is determined by this parameter. It can be adjusted from 0 to 3.

No point "0"

Between first and second digits "0.0"

Between second and third digits "0.00"

Between third and fourth digits "0.000"

PASS

Programming Mode Accessing Password (Default = 0)

Password for entering to the programming mode is defined with this parameter. It can be adjusted from 0 to 9999. If it is 0, programming mode is accessed without entering password.



If no operation is performed in Programming mode for 20 seconds, device turns to main operation screen automatically.



If the process is not exist Alarm output, then **ASeT** , **RoTS** , **ALoL** , **RUPL** , **ALrt** , **RoNd** , **RoFd** , **RoPd** and **ASeT** Parameters is not shown.

4.6 Operation Graphics of Alarm Output and Alarm Types

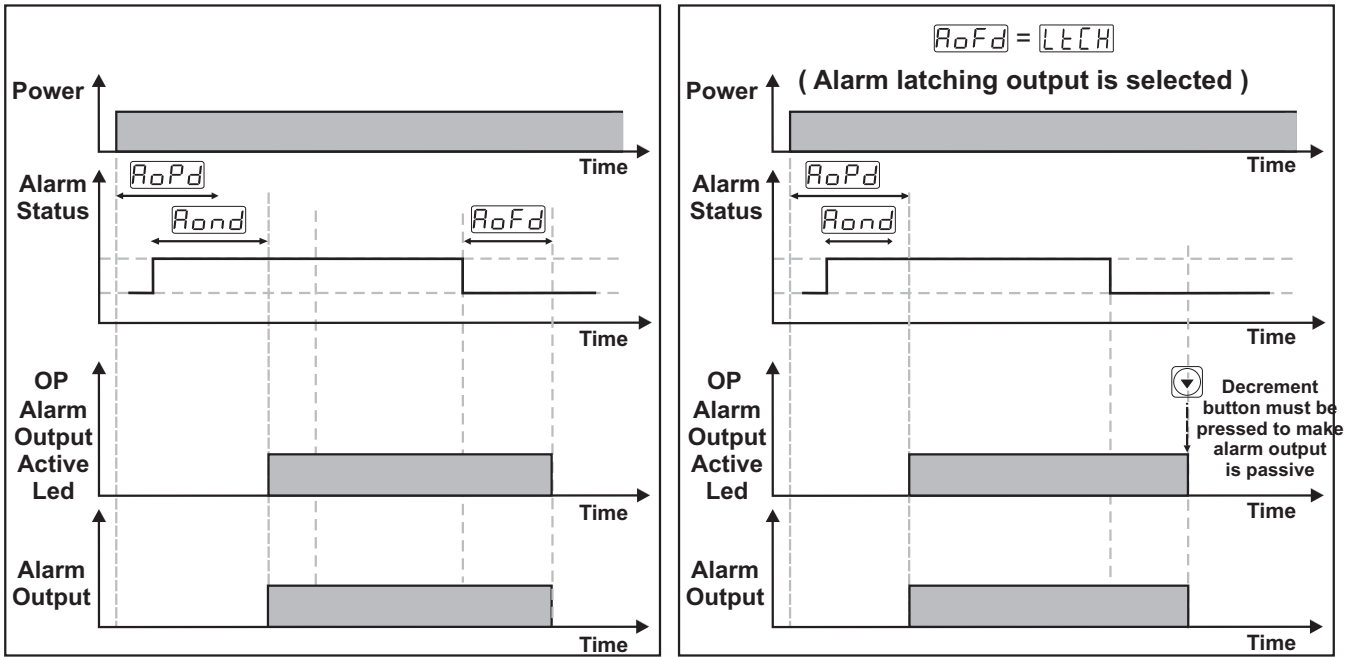

Process High Alarm

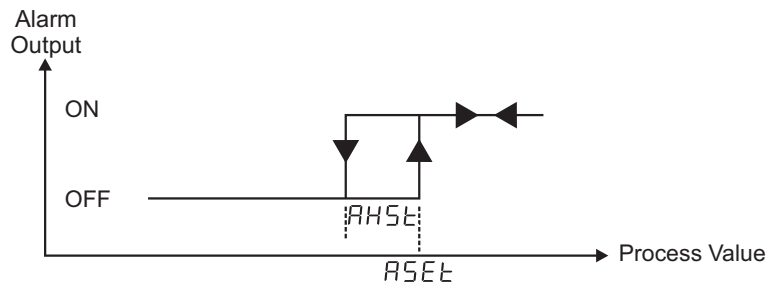

Process Low Alarm

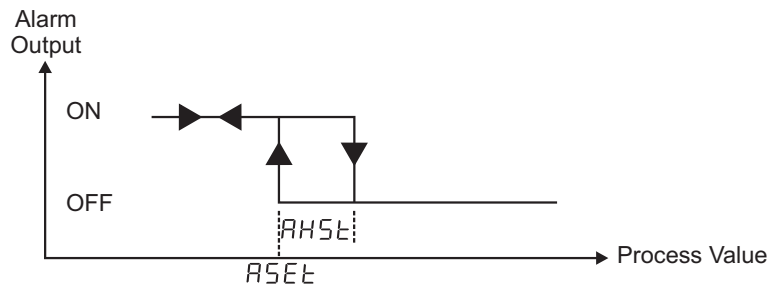

$RSEt$ = Alarm Set Value

Deviation High Alarm

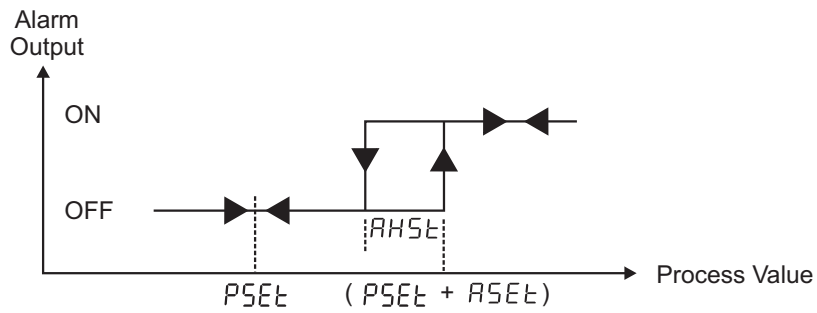

Deviation Low Alarm

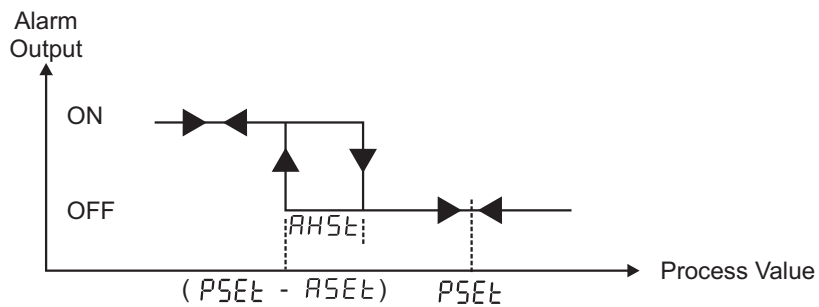

Deviation Band Alarm

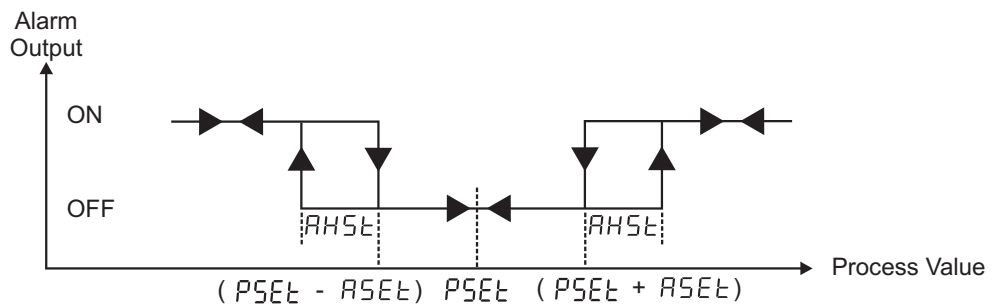

Deviation Range Alarm

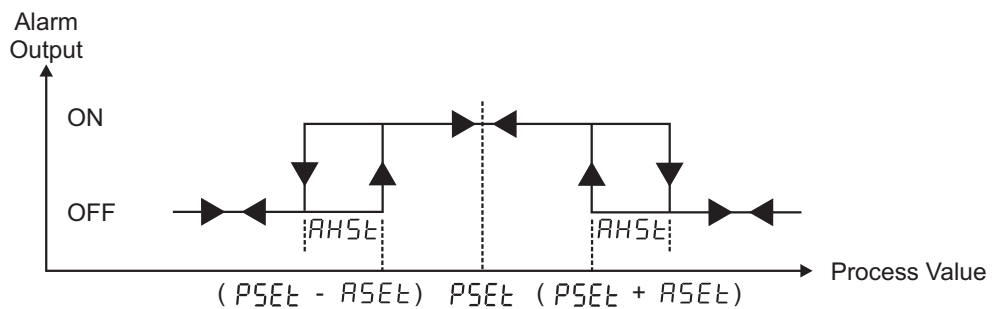

$PSEt$ = Process Set Value

4.7 Easy Access Diagram For Program Parameters

4.7.1 Device With Alarm Output

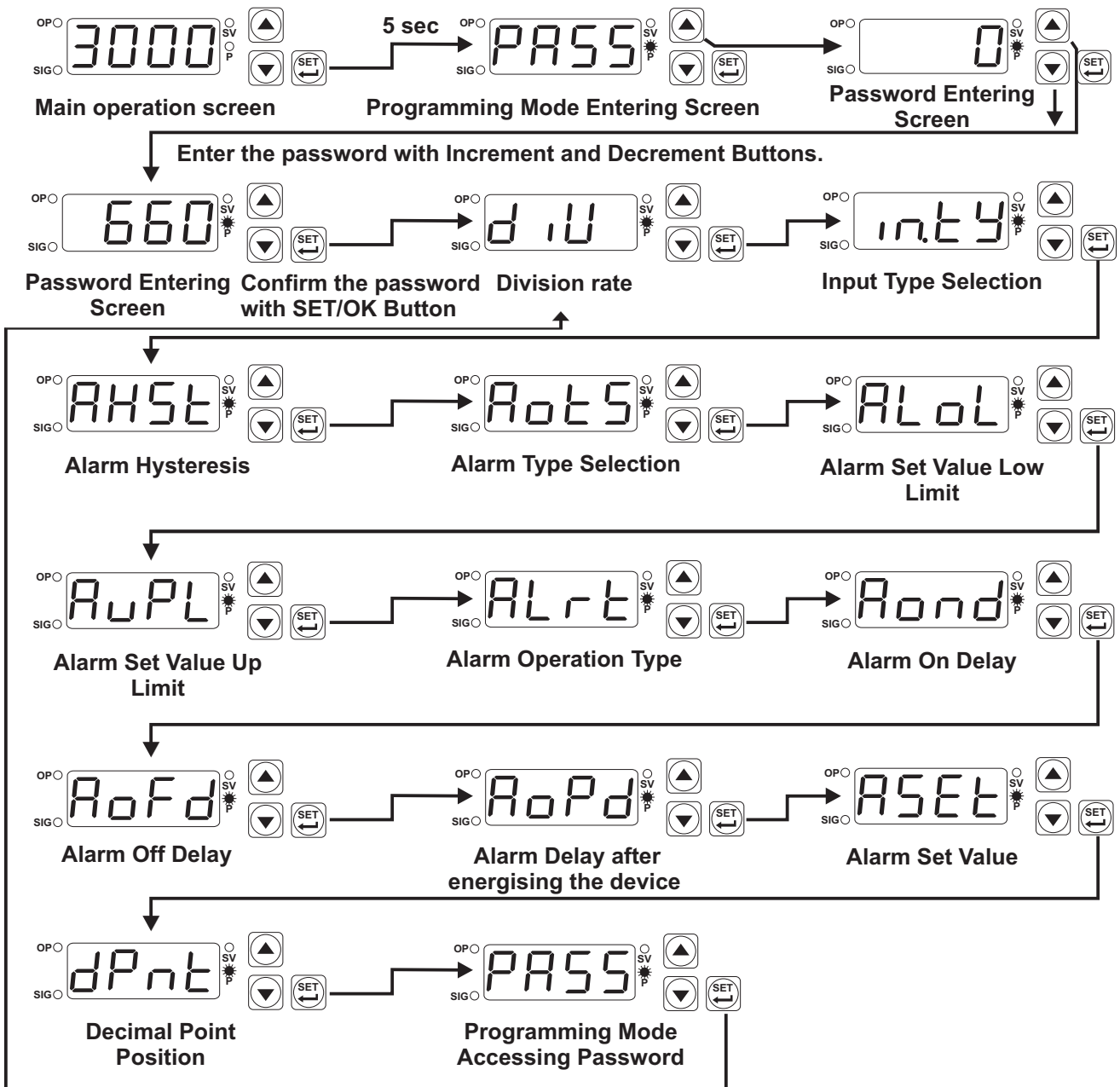

If no operation is performed in Programming mode for 20 seconds, device turns to main operation screen automatically.

4.7.2 Device Without Alarm Output

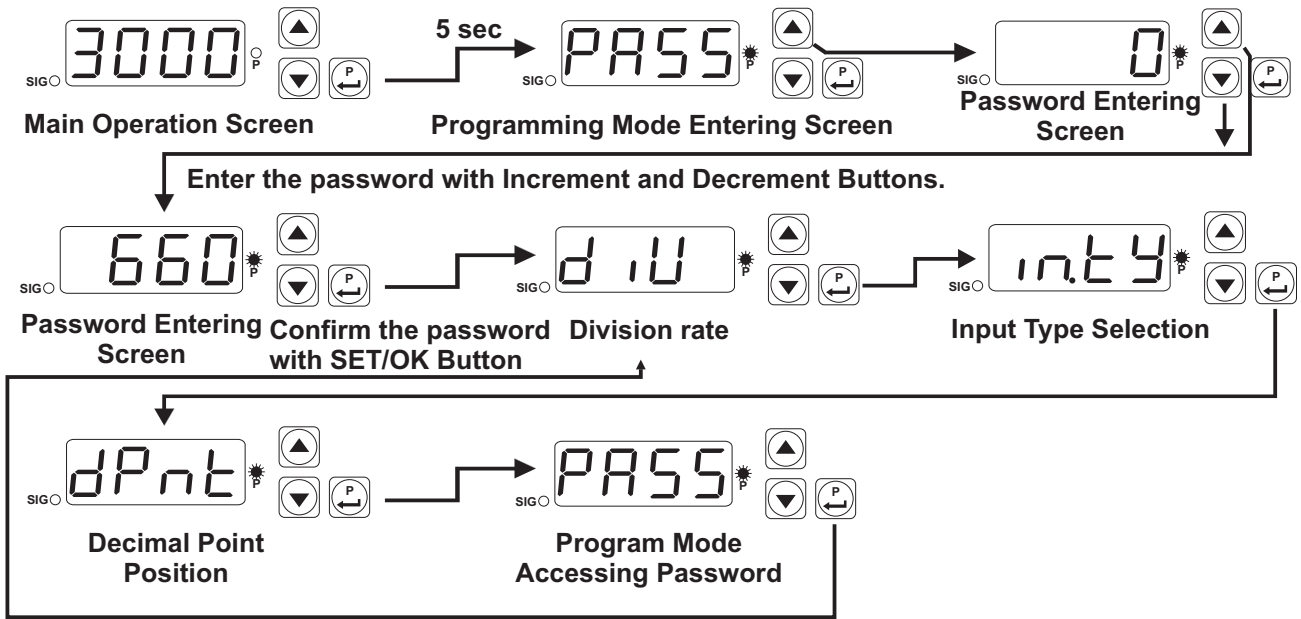

If no operation is performed in Programming mode for 20 seconds, device turns to main operation screen automatically.

4.8 Entering to the Programming Mode, Changing and Saving Parameters

Main Operation Screen



When Set/OK is pressed for 5 sec. "P" led starts flashing. If Programming Mode accessing password is defined, then Program Mode Entering screen `PASS` is shown on the screen.

Note-1: If Programming Mode Access password is 0, then Programming mode entering screen `PASS` is not seen. Division rate `d 1U` parameter is seen

Programming Mode Entering Screen

Press Increment button for accessing to Password Entering Screen



Password Entering Screen

Enter Programming mode accessing password with Increment and decrement buttons.

Password Entering Screen

Confirm the password with using the Set/OK button.

Note-2: Parameters can be observed by pressing SET/OK button in password entering screen without entering the programming mode entering password. But parameters can not be changed.

Programming Screen



Division Rate Parameter

Press increment button for accessing to the parameter value. Press Set/OK button for accessing to the next parameter.

Division Rate Parameter Value

Change the value with increment and decrement buttons.



Division Rate Parameter Value

Press Set/OK button for saving the parameter.

Programming Screen



Division Rate Parameter

Press Set/OK button for accessing to the next parameter.



If no operation is performed in Programming mode for 20 seconds, device turns to main operation screen automatically.

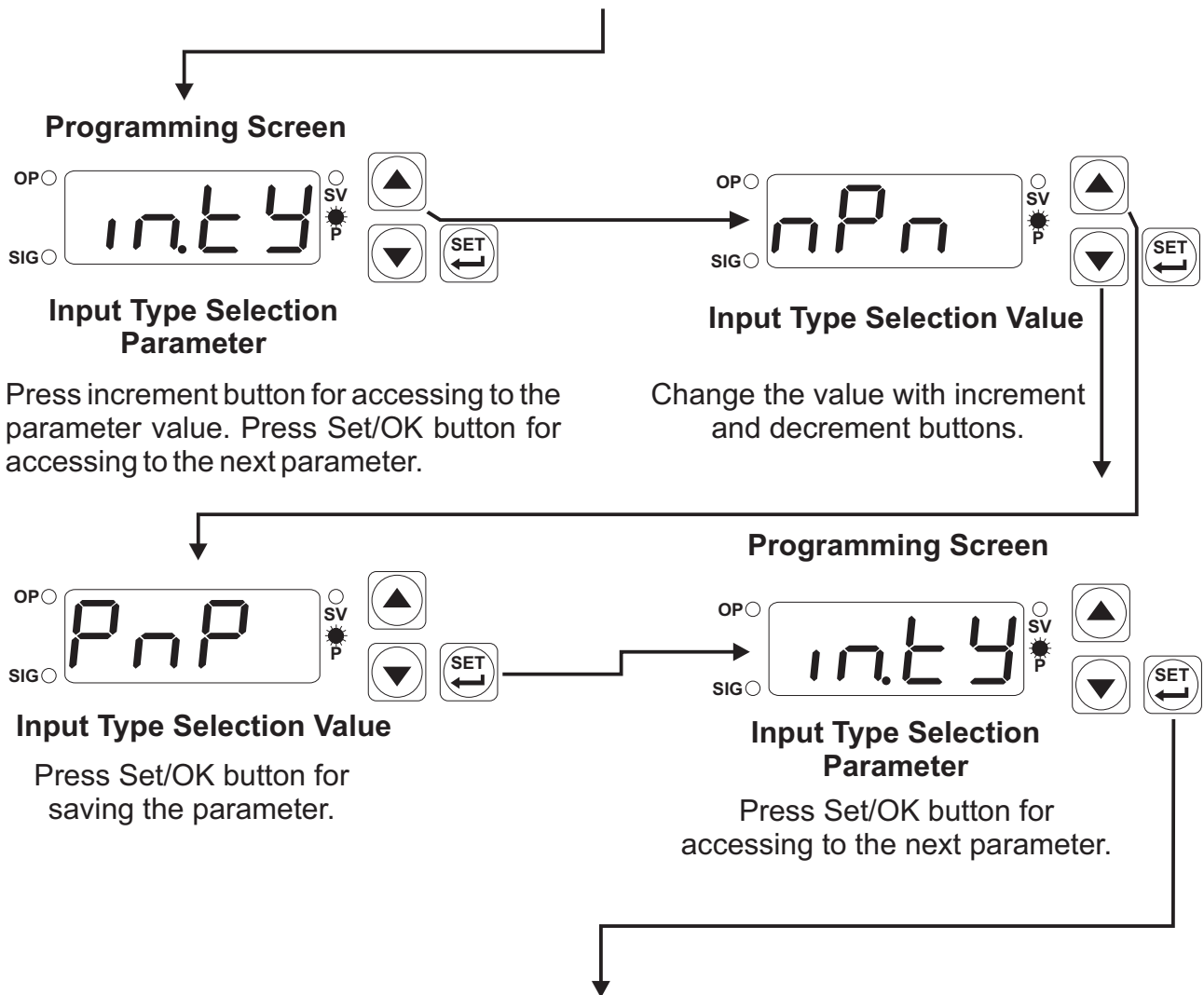

Other Programming mode parameters can be accessed with the same method explained above, observed and changed.



If no operation is performed in Programming mode for 20 seconds, device turns to main operation screen automatically.

5. Failure Messages on ERM-3770 Digital Tachometer

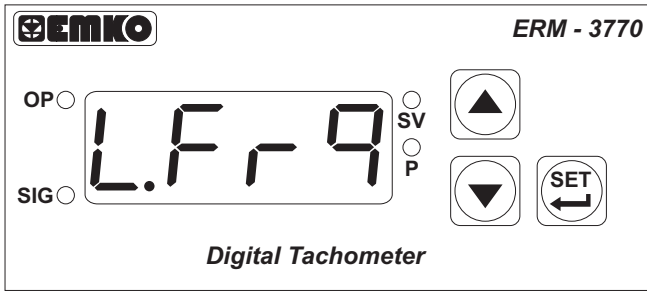

If the input frequency is lower than 0,07 Hz, then this screen will appear.

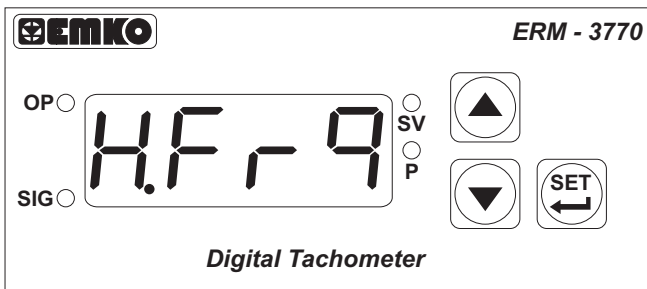

If the input frequency is higher than 10000 Hz, then this screen will appear.

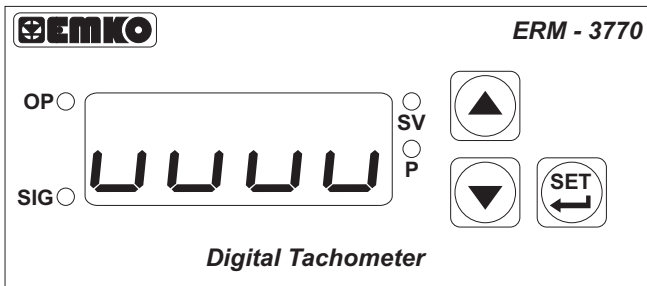

If the Process Value is lower than 1, then this screen will appear.

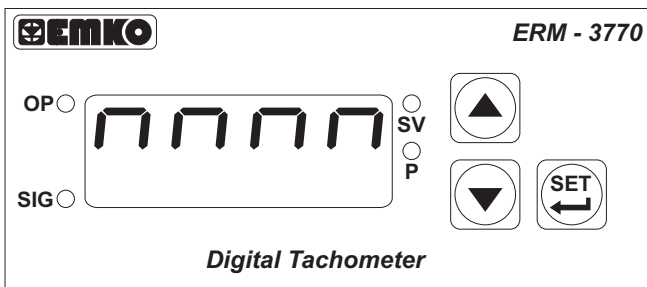

If the Process Value is higher than 9999, then this screen will appear.

6. Specifications

Device Type	: Digital Tachometer
Housing&Mounting	: 77mm x 35mm x 62.5mm plastic housing for panel Mounting. Panel cut-out is 71x29mm.
Protection Class	: IP65 at front, IP20 at rear.
Weight	: Approximately 0.16 kg.
Environmental Ratings	: Standard, indoor at an altitude of less than 2000 meters with none condensing humidity.
Storage / Operating Temperature:	-40 °C to +85 °C / 0 °C to +50 °C
Storage / Operating Humidity	: 90 % max. (None condensing)
Installation	: Fixed installation
Overvoltage Category	: II.
Pollution Degree	: II, office or workplace, none conductive pollution
Operating Conditions	: Continuous
Sensor Supply Voltage	: 12 V _{DC} @ 30 mA (±%35)
Process Input	: Maximum Applicable Voltage : 24 V _{DC} Logic 1 minimum level : 3 V _{DC} Logic 0 maximum level : 2 V _{DC}
Accuracy	: 0.01%
Supply Voltage and Power	: 230 V ~ (-%15;+%15) 50/60 Hz. 1.5 VA 115 V ~ (-%15;+%15) 50/60 Hz. 1.5 VA 24 V ~ (-%15;+%15) 50/60 Hz. 1.5 VA 24 V $\overline{\sim}$ (-%15 ; +%10) 50/60 Hz
Optional Relay Output	: Resistive load 5 A@250 V~ (Electrical Life : Full Load 100.000 switch)
Optional SSR Output	: Maximum 28 mA, Maximum 15 V _{DC}
Display	: 10 mm Red 4 digit LED display
LED displays	: The Device with Alarm Output SV(Green), P(Red), OP(Red), SIG(Red) 3 mm The Device without Alarm Output P(Red), SIG(Red) 3 mm
Approvals	: GOST-R, CE

7. Other Informations

Manufacturer Information:

Emko Elektronik Sanayi ve Ticaret A.Ş.
Demirtaş Organize Sanayi Bölgesi Karanfil Sk. No:6 16369
BURSA/TURKEY
Phone : +90 224 261 1900
Fax : +90 224 261 1912

Repair and Maintenance Service Information:

Emko Elektronik Sanayi ve Ticaret A.Ş.
Demirtaş Organize Sanayi Bölgesi Karanfil Sk. No:6 16369
BURSA/TURKEY
Phone : +90 224 261 1900
Fax : +90 224 261 1912



Thank you very much for your preference to use Emko Elektronik Products.

www.emkoelektronik.com.tr